

# AMERICAN

AMERICAN DRYER CORPORATION 88 CURRANT ROAD / FALL RIVER, MA 02720-4781  
TELEPHONE: (617) 678-9000 / CABLE: AMDRY / TELEX: 927520 AMDRY FRIV

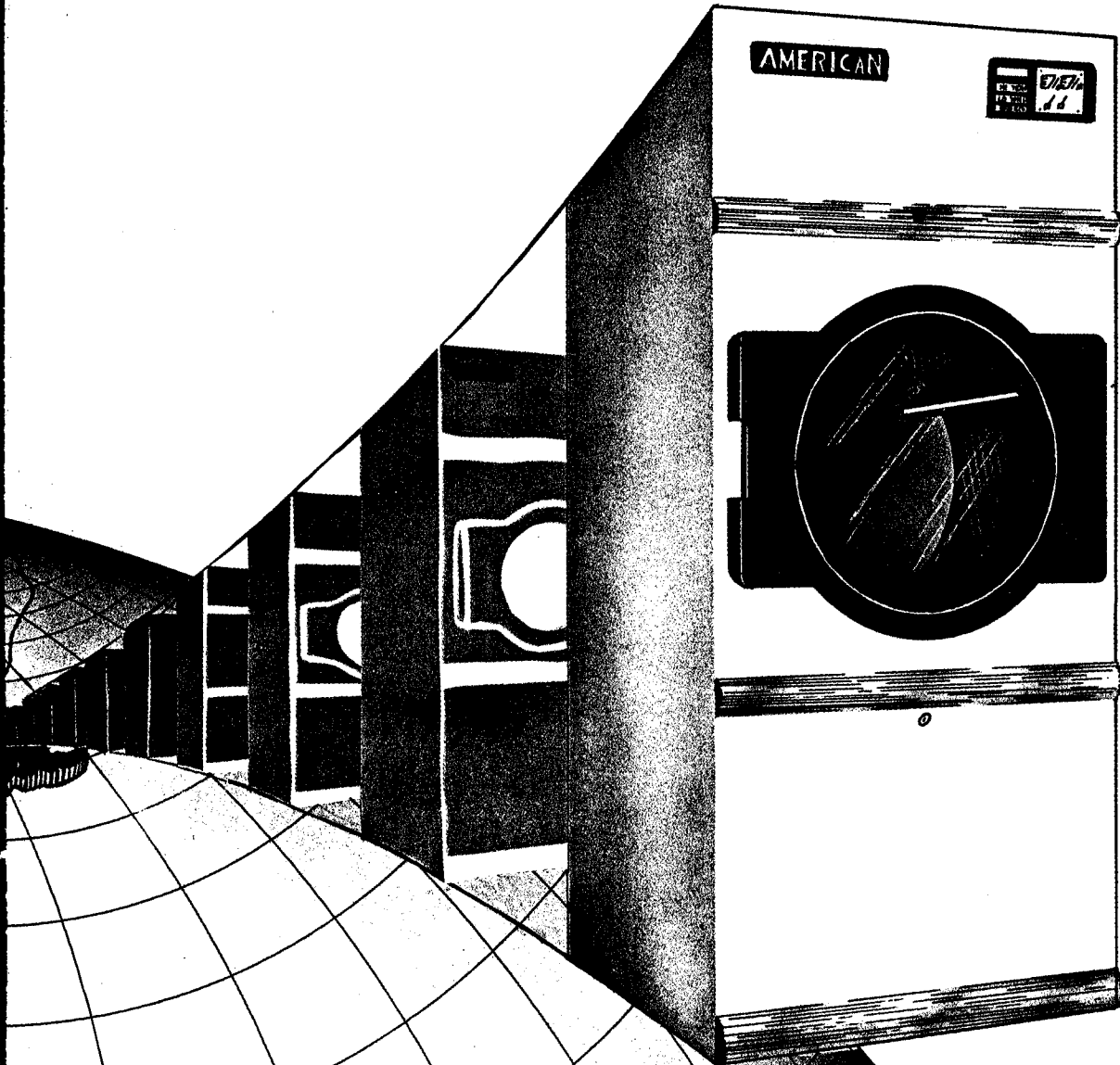

# AMERICAN

INSTALLATION / SERVICE / PARTS

The American dryer embodies advanced concepts in engineering, design, and safety. If this product is properly maintained, it will provide many years of safe, efficient, and trouble-free operation.

American Dryer Corporation is concerned about the future use of this high-quality dryer and the safety of the user. READ THIS MANUAL to familiarize yourself with the proper installation, operation, and service of your dryer.

Note that safety, mechanical, and some general information in this manual is emphasized:

CAUTION: Identifies safety information;  
or  
WARNING:

IMPORTANT: Identifies special mechanical information;

NOTE: Identifies general information worthy of special attention.

RETAIN THIS MANUAL IN A SAFE PLACE FOR FUTURE REFERENCE.

## TABLE OF CONTENTS

### SECTION I Important Information

- A. Receiving and Handling..... 3
- B. Safety Precautions..... 4

### SECTION II Installation Procedures

- A. Unpacking/Set-up..... 6
- B. Location of Dryer..... 6
- C. Dryer Enclosure Requirements..... 7
- D. Fresh Air Supply..... 7
- E. Exhaust Requirements..... 8
- F. Electrical Information..... 8
  - 1. Electrical Requirements..... 8
  - 2. Electrical Service Specifications..... 9
  - 3. Grounding..... 10
  - 4. Electrical Connections..... 10
  - 5. 3-Phase Wiring Connections..... 11
- G. Gas Information..... 11
  - 1. Gas Supply..... 11
  - 2. Technical Gas Data..... 12
  - 3. Piping/Connections..... 12
- H. Preparation for Operation..... 14
- I. Pre-operational Test..... 15

### SECTION III Operating Instructions

- A. Mechanical Coin Meter Controls (non-computer)..... 17
  - 1. Components..... 17
  - 2. Operating Sequence..... 17
- B. Computer Controls..... 18
  - 1. Introduction and Features..... 18
  - 2. L.E.D. Display and Codes..... 22
  - 3. Operating Instructions..... 24
    - a. Timed Mode..... 24
    - b. Automatic Mode..... 24
    - c. Free Dry..... 25
  - 4. Program Selections..... 26
  - 5. Introduction to Programming..... 36
  - 6. Programming..... 38
    - a. Temperature Display Mode..... 38
    - b. Right Coin Count..... 39
    - c. Left Coin Count..... 40
    - d. Program Location 01 (PL01)..... 41
    - e. Number of Auto Peaks (Dryness Level)(PL02).. 45
    - f. HI temp (PL03)..... 46
    - g. HI temp Cool Down Temperature/Time (PL04)... 47
    - h. LO temp (PL05)..... 48
    - i. LO temp Cool Down Temperature/Time (PL06)... 49
    - j. Perm Press Temperature (PL07)..... 50

k.	Perm Press Cool Down Temperature/Time (PL08)	51
l.	Left Coin Denomination (PL09).....	52
m.	Right Coin Denomination (PL10).....	53
n.	Time Per Left Coin (PL11).....	54
o.	Amount to Start (PL12).....	55
p.	Coin Accumulation Minimum Amount for More Time (PL13).....	56
q.	Maximum Time for Auto Dry (PL14).....	57
r.	Anti-Wrinkle Timing (PL15).....	58
s.	Maximum Active Anti-Wrinkle Time (PL16).....	59
7.	Factory Preset Programs	
a.	Dual Coin.....	60
b.	Single Coin.....	61
8.	Optional 9 Volt Battery Backup.....	62
SECTION IV	<u>Heat/Ignition Circuit Operation</u>	
A.	Standard Glo-bar System (non-computer).....	63
B.	Computer Controlled Hi/Lo Gas Valve System.....	64
1.	Introduction.....	65
2.	System Components.....	65
3.	Operation Sequence.....	65
SECTION V	<u>Maintenance</u>	
A.	Cleaning.....	67
B.	Adjustments.....	68
C.	Lubricating.....	68
SECTION VI	<u>Parts Manual Illustrations and Descriptions.....</u>	69
SECTION VII	<u>Trouble Shooting</u>	
A.	Mechanical Coin Meter Controls (non-computer).....	106
B.	Computer Controls.....	109
SECTION VIII	<u>Servicing.....</u>	115
SECTION IX	<u>Technical Data.....</u>	143
SECTION X	<u>Mastercard/Visa Credit Card Information.....</u>	155

## SECTION I

### Important Information

#### A. Receiving and Handling

The dryer is shipped with a protective polyethylene cover and protective corners and is enclosed in a cardboard carton as a means of protection in transit. Upon delivery, the shipping carton and wooden skid should be visually inspected for shipping damage. If carton or wooden skid is damaged, inspect further.

#### Dryers Damaged in Shipment

1. All dryers should be inspected upon receipt and before they are signed for.
2. If there is suspected damage or actual damage, the trucker's receipt should be so noted.
3. If the dryer is damaged beyond repair, it should be refused. Those dryers which were not damaged in a damaged shipment should be accepted, but the number received and number refused must be noted on the receipt.
4. If you determine that the dryer has been damaged after the trucker has left your location, you should call your local freight terminal immediately and request an inspection and freight claim form. The freight company considers this concealed damage. This type of freight claim is very difficult to get paid and becomes extremely difficult when more than a day or two passes after the freight was delivered.
5. If you need assistance in handling the situation, please call Monique Sullivan at American Dryer Corporation.

IMPORTANT: The dryer should be transported and handled in an upright position at all times.

## B. Safety Precautions

1. Do not store or use gasoline or other flammable vapors and liquids in the vicinity of this or any other appliance.
2. Purchaser/user should consult the local gas supplier for proper instructions to be followed in the event the user smells gas. The instructions should be posted in a prominent location.
3. Dryer must be exhausted to the outdoors.
4. Although the American dryer is a very versatile machine, there are some articles that, due to fabric composition or cleaning method, should not be dried in it.

WARNING: Dry only water-washed fabrics. Do not dry articles spotted or washed in dry cleaning solvents, a combustible detergent, or "all purpose" cleaners. Fire or explosion could result.

WARNING: Do not dry rags or articles coated with gasoline, kerosene, paint, wax, or grease. Fire or explosion could result.

WARNING: Do not dry mopheads. Contamination by wax or flammable solvents will create a fire hazard.

WARNING: Do not use heat for drying articles that contain plastic, foam, or sponge rubber, or similarly textured rubber-like materials. Drying in a heated tumbler may damage plastics or rubber and also may be a fire hazard.

5. A program should be established for the inspection and cleaning of the lint in the burner area and exhaust duct work. The frequency of inspection and cleaning can best be determined from experience at each location.

WARNING: The collection of lint in the burner area and exhaust duct work can create a potential fire hazard.

6. For personal safety, the dryer must be electrically grounded in accordance with local codes and/or the National Electric Code ANSI/NFPA No. 70-1984.

NOTE: Failure to do so will void warranty.

7. Under no circumstances should the dryer door switch or heat circuit safety devices ever be disabled.

WARNING: Personal injury or fire could result.

8. READ AND FOLLOW ALL CAUTION AND DIRECTION LABELS ATTACHED TO DRYER.

## SECTION II

### Installation Procedures

Installation should be performed by competent technicians in accordance with local and state codes. In the absence of these codes, installation must conform to applicable AMERICAN NATIONAL STANDARDS:

ANSI Z223.1 - 1984 (NATIONAL FUEL GAS CODE) or  
ANSI/NFPA NO. 70-1984 (NATIONAL ELECTRIC CODE)

#### A. Unpacking/Set Up

Remove shipping carton, polyethylene cover and protective shipping corners from dryer. For shipping purposes, the main door handle, magnet channel assembly, and mounting screws are shipped in the tumbler. Remove tape and foam pad from main door area and install door handle and channel assembly to door.

NOTE: The access keys to the coin box, control (service) door, and lint door are shipped in the dryer and should be removed and put in a safe place. However, the MK-100 key (master key for both control and lint doors) should be made accessible, because it will be needed throughout various phases in the installation of the unit.

The dryer can be moved to its final location while still attached to the skid or with the skid removed. To un-skid the dryer, locate and remove the four (4) bolts securing the base of the dryer to the wooden skid. Two (2) are located at the rear base, and two (2) are located in the lint chamber. Once the bolts are removed, slide the dryer off the skid.

With the skid removed, move the dryer to its permanent operating location. The dryer is equipped with four (4) leveling legs located at each corner. Two (2) are located at the rear of the dryer base, and two (2) are located in the lint chamber.

NOTE: To increase bearing life and improve efficiency, the dryer should be tilted slightly to the rear.

#### B. Location of the Dryer

Before installing the dryer, be sure the location conforms to local codes and ordinances.



The dryer must be installed on a sound, level floor capable of supporting its weight. It is recommended that carpeting be removed from the floor area that the dryer is to rest on.

It is recommended that the rear of the dryer be positioned about two (2) feet away from the nearest obstruction (i.e., wall) for ease of installation, maintenance, and service.

#### C. Dryer Enclosure Requirements

Bulkheads and partitions should be made of non-combustible materials and must be located a minimum of twelve (12) inches above the dryer outer top, except along the front of the dryer which may be closed in if desired.

NOTE: Allowance must be made for opening the control door.

Dryers may be positioned side wall to side wall. However, allowances should be made for the opening and closing of the control and lint doors. A minimum of two (2) inches is required from the rear of the dryer to the nearest obstruction (i.e., wall). It is suggested that the dryer be positioned about two (2) feet away from the nearest rear obstruction for ease of installation, maintenance, and service. See page 145 for other detailed enclosure requirements.

NOTE: Air considerations are important for proper and efficient operation.

#### D. Fresh Air Supply

Air supply (make-up air) must be given careful consideration to assure proper performance of each dryer. An unrestricted source of air for 375 CFM is necessary for each dryer. An unrestricted air entrance from the outdoors (atmosphere) of a minimum of eight (8) square inches is required for each dryer. As a general rule, for simplicity's sake, we suggest one (1) square foot per dryer, which includes compensation for registers or louvres. It is not necessary to have a separate make-up air opening for each dryer. Common make-up air openings are acceptable. However, they must be set up in such a manner that the make-up air is distributed equally to the dryers. Example: for a bank of eight (8) dryers, two (2) openings measuring 2'x2' (4 square feet) is acceptable.

Allowances must be made for remote or constricting passageways or where dryers are located at excessive altitudes or predominantly low pressure areas.

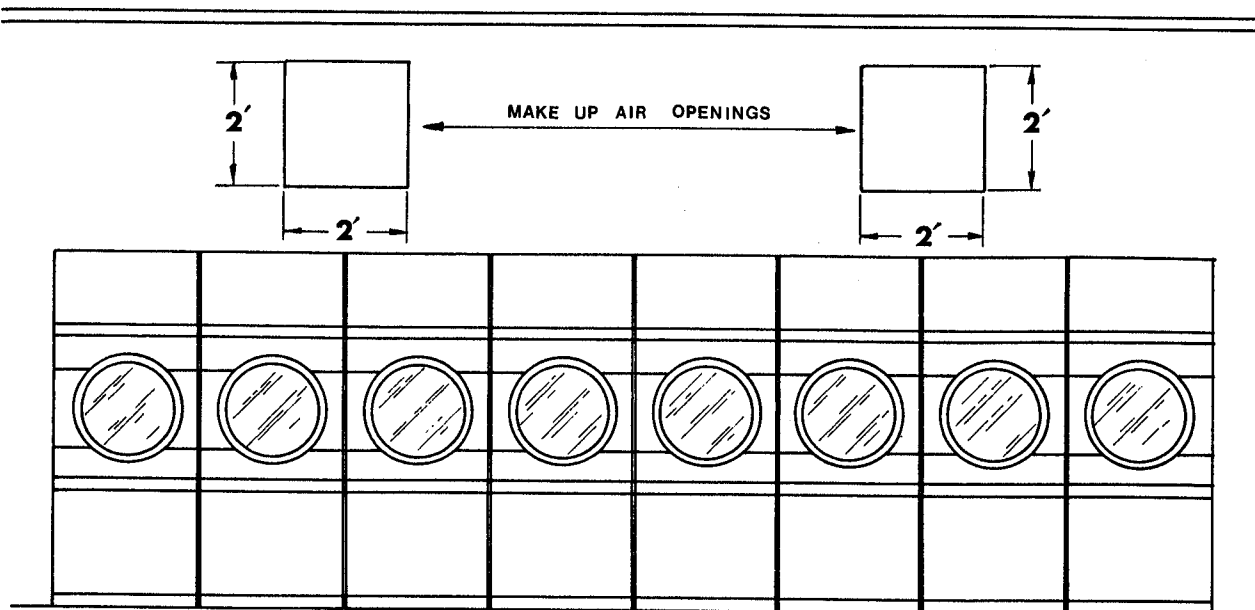

TYPICAL INSTALLATION SHOWING MAKE-UP  
AIR OPENINGS

IMPORTANT: Make-up air must be provided from a source free of dry cleaning fumes. Make-up air contaminated by dry cleaning fumes will result in irreparable damage to motors and other dryer components.

NOTE: Component failure due to dry cleaning fumes voids warranty.

#### E. Exhaust Requirements

Exhaust duct work should be designed and installed by a competent technician. Improperly sized duct work will create excessive back pressure which results in slow drying, increased use of energy, and shutdown of the burner by the air flow (sail) switch, burner hi-limit or lint chamber hi-heat protector thermostat. See page 146 for exhaust duct work specifications and details.

CAUTION: Improperly sized or installed exhaust duct work can create a potential fire hazard.

#### F. Electrical Information

##### 1. Electrical Requirements

It is your responsibility to have all electrical connections

made by a properly licensed and competent electrician to assure that the electrical installation is adequate and conforms with local and state regulations or codes. In the absence of such codes, all electrical connections, material, and workmanship must conform to the applicable requirements of the NATIONAL ELECTRIC CODE ANSI/NFPA NO. 70-1984.

IMPORTANT: Failure to comply with these codes or ordinances, and/or the requirements stipulated in this manual can result in personal injury or component failure.

NOTE: Component failure due to improper installation voids warranty.

It is recommended that a separate circuit serving each dryer be provided. The dryer must be connected to copper wire only. Do not use aluminum wire which could cause a fire hazard.

NOTE: The use of aluminum wire voids warranty.

## 2. Electrical Service Specifications

Electric Service			Dryer Amp. Draw	Recommended Specs	
Voltage	Phase	No. of Wires		Wire Size	Breaker Size
115	1	2	14	12	20A.
208/230	1	2	7	14	15A.*
208/230	3	3	5	14	15A.

\* 2-pole circuit breaker is required.

IMPORTANT: The dryer must be connected to the electrical supply shown on the data label located on the rear side of the control door. In the case of 208 or 230 volts, the supply voltage must match the electric service specs of the data label exactly. The voltages 208 and 230 are not the same. Should it be found that the dryer was manufactured for operation at 230 volts and the service supply voltage is 208 volts, (or vice versa), a slight wiring change is necessary at the heat circuit transformer. This transformer is located behind the control wire box and is used to step down the control (primary) voltage (i.e., 208 or 230) down to 110 volts. The transformer is dual (primary) voltage; however, it must be wired accordingly. In the case of 208 volts, the yellow

primary lead must be used, and the red lead dead ended. For 230 volts, the red primary lead must be used, and the yellow lead dead ended. See the wiring diagram located on the rear side of the control door.

NOTE: Component failure due to improper voltage application will void warranty.

### 3. Grounding

A ground (earth) connection must be provided and installed in accordance with state and local codes. In the absence of these codes, grounding must conform to applicable requirements of the NATIONAL ELECTRIC CODE (ANSI/NFPA NO. 70-1984). The ground connection may be to a proven earth ground at the location service panel.

For added personal safety, when possible, it is suggested that a separate ground wire (no. 18 minimum) be connected from the ground connection of the dryer to a grounded cold water pipe. Do not ground to a gas pipe. The grounded cold water pipe must have metal to metal connection all the way to electrical ground. If there are any non-metallic interruptions, such as, a meter, pump, plastic, rubber, or other insulating connectors, they must be jumped with no. 4 copper wire and securely clamped to bare metal at both ends.

IMPORTANT: For personal safety and proper operation, the dryer must be grounded.

### 4. Electrical Connections

A wiring diagram is located on the back side of the control (service) door for connection data.

The electrical connections for dryers manufactured for operation at single phase (2-wire) are made through the front, inner top area above the control panel wire box. The dryer is shipped with the three (3) connection leads (L1, L2 or N, and ground) extending out of the inner top connector hole.

Electrical Connection Leads		
Black	White	Green
+	-	
Positive	Neutral or L2	Ground

If local codes permit, power to the dryer can be made by the use of a flexible U.L. listed power cord/pigtail (wire size must conform to rating of dryer) or the dryer can be hard wired directly to the service breaker panel. In both cases, a strain relief must be installed where the wiring enters the dryer.

NOTE: It is recommended that a circuit serving each dryer be provided.

## 5. 3-Phase Wiring Connections

For dryers manufactured for operation at 3 phase, the electrical connections are made at the 3 pole contactor (relay) located in the service box at the rear, upper left corner of the dryer. To gain access to the service box and contactor, the back guard and service box cover must be removed.

Providing local codes permit, power to the dryer can be made by the use of a flexible U.L. listed chord/pigtail (wire size must conform to the rating of the dryer), or the dryer can be hard wired directly to the service breaker. The power supply wiring may enter the dryer through the top back area at the outer top or through the upper back guard section. In all cases, a strain relief should be used both where the wiring enters the dryer and the service box.

NOTE: It is recommended that a circuit serving each dryer be provided.

CAUTION: The dryer must be grounded. A ground lug has been provided in the service box for this purpose.

The only electrical connections to the dryer are the 3-phase leads (L1, L2, and L3) and ground. Single-phase power (208/230V) for the control circuit is done by the factory at the contactor (relay), and no other wiring connections are necessary.

## G. Gas Information

### 1. Gas Supply

The gas dryer installation must meet the AMERICAN NATIONAL STANDARD, NATIONAL FUEL GAS CODE ANSI Z223.1-1984, as well as, local codes and ordinances and must be done by a qualified technician.

NOTE: Undersized gas piping will result in ignition problems, slow drying, and increased use of energy and can create a safety hazard.

The dryer must be connected to the type of heat/gas indicated on the dryer data label located on the back side of the control door. If this information does not agree with the type

of gas available, contact the distributor who sold the dryer or the factory.

NOTE: Any burner changes must be made by a qualified technician.

The gas input ratings shown on the dryer data label are for elevations up to 2,000 feet, unless elevation requirements of over 2,000 feet were specified at the time the dryer order was placed with the factory. The adjustment for dryers in the field for elevations over 2,000 feet are made by changing the burner orifices. If this adjustment is necessary, contact the distributor who sold the dryer or contact the factory.

NOTE: Any burner changes must be made by a qualified technician.

## 2. Technical Gas Data

Technical Gas Data						
Type Ignition System	Hi/Lo			Standard Glo-Bar*		
Type of Gas	Natural	Propane	Butane	Natural	Propane	Butane
Manifold Pressure**	4"	11"	11"	4"	11"	11"
Inline Pressure(W.C.)	6"-12"	11"	11"	6"-12"	11"	11"
Orifice Size (D.M.S.)	30	52	1/16"	32	50	51
Gas Inlet Size	←————— 1/2" N.P.T. —————→					
BTUH Input	←————— 72,000 —————→			←————— 78,000 —————→		

\* Non-computer models

\*\* At gas valve pressure tap. Measured in inches of water column.

(D.M.S.) Drill manufacturer's standard - equivalent to standard twist drill or steel wire guage numbers.

(W.C.) Water column in inches.

## 3. Piping/Connections

The dryer is provided with a 1/2" N.P.T. inlet pipe connection extending out the rear area of the dryer. The installer also has the option for the gas supply line to be connected through the front inner top area of the dryer. It is recommended that a gas shut-off valve serving each dryer be provided.

The size of the gas supply line (header) will vary depending on the distance this supply line travels from the gas meter or, in the case of L.P. gas, the supply tank, the amount of tees, other gas-operated appliances, etc. Specific information regarding supply line size should be determined by the gas supplier.

NOTE: Undersized gas supply piping can create a low or inconsistent gas pressure which will result in erratic operation of the burner ignition system.

Consistent gas pressure is essential at all gas connections. It is recommended that a 3/4" pipe gas loop be installed in the supply line serving the bank of dryers. An inline pressure regulator must be installed in the gas supply line (header) if (natural) gas line pressure exceeds 12 inches water column pressure.

IMPORTANT: Water column pressure of 4 inches is required at the gas valve pressure tap of each dryer for proper and safe operation.

A 1/8" N.P.T. plugged tapping, accessible for test gauge connection, must be installed in the main gas supply line immediately upstream of the dryer.

IMPORTANT: Pipe joint compounds that resist the action of natural and L.P. gas must be used.

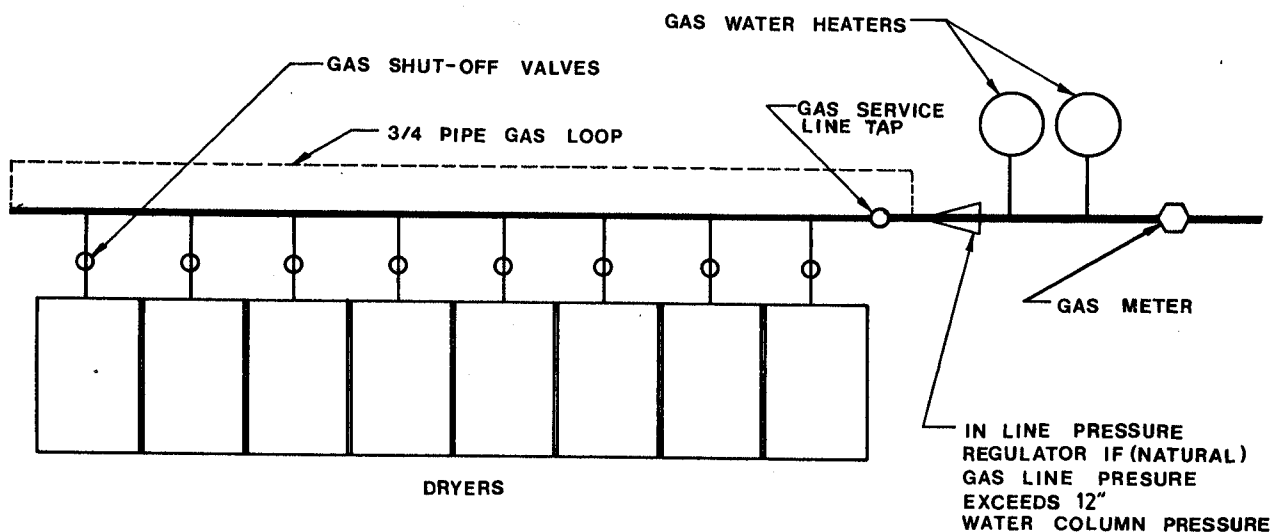

TYPICAL NATURAL GAS INSTALLATION

## Liquid Petroleum (L.P.) Gas

Dryers manufactured for use with liquid petroleum (L.P. gas) have no pressure regulator or means of regulation built into the dryer. Regulation must be provided at the gas supply (L.P. tank) or, in the case where another gas appliance of a higher required gas pressure is on the same supply line, separate regulators (vented to the outdoors) serving each dryer should be provided.

IMPORTANT: Water column pressure of 11 inches is required at the gas valve pressure tap of each dryer for proper and safe operation.

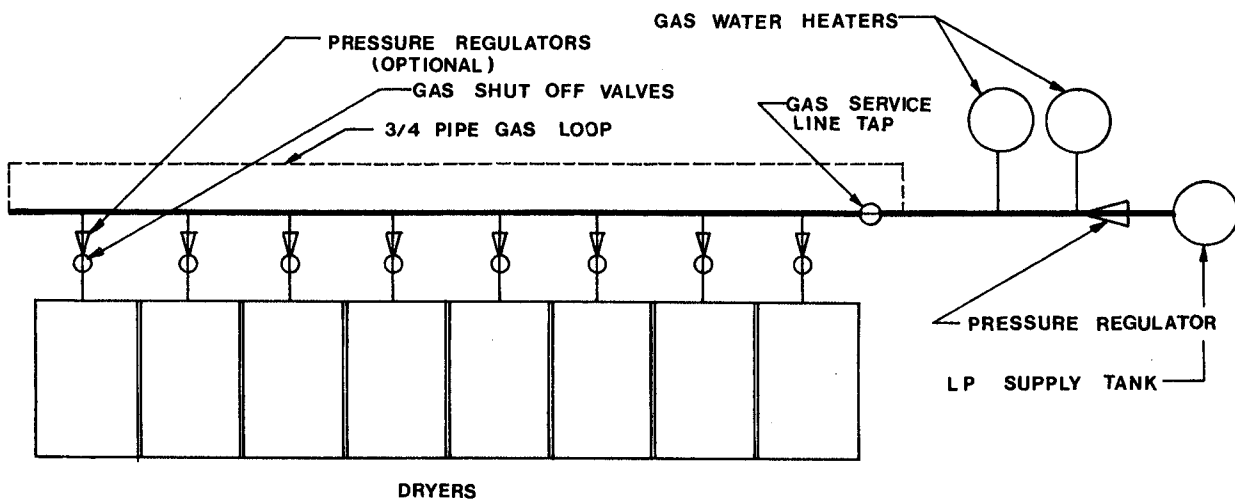

TYPICAL L.P. GAS INSTALLATION

WARNING: Test all connections for leaks by brushing on a soapy water solution (Liquid detergent also works well.) NEVER TEST FOR GAS LEAKS WITH A FLAME.

All components/materials must conform to National Fuel Gas Code specifications. It is important that gas pressure regulators meet applicable pressure requirements, and gas meters be rated for the total amount of appliance BTU's being supplied.

### H. Preparation for Operation

The following items should be checked before attempting to



operate the dryer:

1. Read and follow all caution, warning and direction labels attached to the dryer.
2. Check incoming supply voltage to be sure that it is the same as indicated on the dryer data label located on the rear side of the control door.
3. Check to assure that the dryer is connected to the type of heat/gas indicated on the dryer data label.
4. The sail switch damper assembly is installed and pre-adjusted at the factory prior to dryer shipment. However, the sail switch adjustment must be checked to assure that this important safety control is functioning.
5. Check bolts, nuts, screws, terminals, and fittings for security.
6. Be sure all gas shut-off valves are in the open position.
7. Be sure all back guard panels and service box covers (3-phase models only) have been replaced.
8. Check the lint door to assure that it is closed and secured in place.

IMPORTANT: If during installation the lint door safety chain was disconnected, it must be reconnected or personal injury may result.

9. Rotate the tumbler (drum) by hand to be sure it moves freely.

#### I. Pre-operational Test

All dryers are thoroughly tested and inspected before leaving the factory. However, a pre-operational test should be taken before the dryer is publicly used. It is possible that adjustments have changed in transit.

1. Turn on electric power to dryer.
2. Refer to the operating instructions for starting your particular model dryer.
3. Start dryer. Using a "high heat" selection, accumulate about 20 minutes of time.
4. Remove air from the gas line. Run the dryer about 5

minutes. If the burner does not ignite during these 5 minutes, turn the dryer off and wait a few minutes.

NOTE: The dryer has a safety device (I.R. sensor) which shuts off the gas if the burner does not ignite in a short time. Wait a few minutes for this safety device to reset.

During this waiting period, check to be sure all gas shut-off valves are open. If the dryer still fails to heat, refer to the trouble shooting section.

5. Make a complete operational check of all the operating controls to assure that the timing is correct, temperature selection switches are functioning, etc.
6. Make a complete operational check of all safety related circuits. Door switch(es), hi-limit thermostat, sail switch, cycling thermostats, etc.
7. A gas pressure test should be taken at the gas valve pressure tap of each dryer to assure that the water column pressure is correct and consistent.

NOTE: Water column pressure requirements:

Natural Gas - 4 inches W.C.

L.P. Gas - 11 inches W.C.

8. If computer program changes are required, refer to the Phase 3 Coin Introduction section of this manual.
9. The dryer should be operated through one complete cycle to assure that no further adjustments are necessary and that all components are functioning properly.

IMPORTANT: The dryer tumbler (basket/drum) is treated with a protective coating. We suggest tumbling old clothes or material in the basket using a mild detergent to remove coating.

10. On models manufactured for 3-phase electrical input voltage, check the electric service phase sequence. While the dryer is operating, check to see if the tumbler (basket/drum) is rotating in the clockwise direction (when viewed from the front). If so, the phasing is correct. If the tumbler rotates counter-clockwise, the phasing is incorrect. Correct by reversing two (2) leads at connections L1, L2, or L3 of power supply to the dryer.

## SECTION III

### Operating Instructions

#### A. Mechanical Coin Meter Controls (non-computer)

1. The controls of a mechanical coin-metered model dryer consist of:

<u>Component</u>	<u>Function</u>
Coin Meter	Permits the dryer to be started after the insertion of coins. The meter also controls the timing of the drying and cooling cycles.
Heat Selector Switch	Controls the temperature during the drying cycle.
"Push to Start" Button	Safety Device which must be manually "pressed" to start the dryer. Whenever the dryer is stopped by opening the main door during a cycle, the "Push to Start" button must be pressed to restart the dryer.
Indicator Light	Lights to indicate that the dryer is in the drying or cooling cycle.

#### 2. Operating Sequence

- a. Insert coin. Rotate knob fully clockwise and release after coin is accepted.
- b. Make temperature selection in accordance with the type of material being dried.
- c. To start unit, press "Push to Start" button.

NOTE: Main door must be closed.

- d. The dryer will start, and the heat circuit will activate.
- e. During operation, the heat circuit will continue to be active until the thermostat controlling the "temperature selected" is satisfied and opens. The dryer will continue to operate under these conditions until the dryer enters the cool down cycle or until the completion of metered time.

Time can be accumulated at any time by the insertion of more coins. Cool down time is not accumulative.

The dryer can be stopped at any time by opening the main door. While the door is open, the meter will continue to count time. Continuation of the cycle will only resume after the door is closed and the "Push to Start" button is again depressed.

## B. Computer Controls

### 1. Introduction

The Phase 3 computerized system is a fully programmable, highly sophisticated dryer control system. American has designed the Phase 3 to be the most versatile and reliable coin-op control system available.

To eliminate as many moving parts as possible, all Phase 3 programming is done through the membrane switch on the front of the control panel. The switch (PS) that puts the computer into the program mode is a single, sealed, military specification toggle switch. This toggle switch (PS) eliminates the possibility of switch failure due to an accumulation of lint or moisture.

### Phase 3 Features

#### PROGRAMMABLE

Changes in programs are made at the temperature selection keyboard, and actual programs are displayed for verification.

#### ADJUSTABLE TIME

Programmable from a minimum of 1 minute to a maximum of 99 minutes in 1-minute increments.

#### COIN ACCEPTOR DENOMINATIONS

Values of the coin acceptors are programmable from a minimum of 1 to a maximum value of 9999 for any U.S. or foreign coin denomination.

#### AMOUNT TO START

Programmable from a minimum value of 1 to a maximum value of 9999 in increments of 1.

### ACCUMULATIVE TIME

This program yields a specific value of time for any coin entry made after the amount to start has been inserted.

### ACCUMULATIVE COIN

This program selection requires that a specific value of coin(s) be inserted for additional time, programmable for any minimum amount.

### COIN COUNT

The number of coins inserted, including a separate display program for optional dual coin acceptors, can be viewed through the L.E.D. display.

### BAD COIN LOCKOUT

Each coin entry is monitored. Should someone tamper with the coin acceptor or attempt to insert a foreign object, the computer will stop the dryer, lock up, and display "OFF" until reset, programmable to be reset either manually or automatically.

### TEMPERATURE CONVERSION STATUS

Temperature-related circuits are programmable to be operated in Fahrenheit or Celsius. Programs effected are:

1. Temperature display mode
2. Temperature selections
3. Cool down temperatures

### DRYING TEMPERATURES

Any of the three (3) temperature selections (HI/LO/PP) are programmable from a minimum of 100° F. to a maximum of 190° F. in 10° increments or from a minimum of 35° C. to a maximum of 90° C. in 5° increments. Actual temperature programs are displayed at time of programming for verification.

### COOL DOWN TIME

All three (3) temperature selections are programmable from a minimum of 0 to a maximum of 9 minutes in 1-minute increments.

## COOL DOWN TEMPERATURES

In the automatic or free dry modes the cool down cycle termination is programmable from a minimum of 100° F. to a maximum of 190° F. in 10° increments or from a minimum of 35° C. to a maximum of 90° C. in 5° increments.

## AUTOMATIC MODE

This program will cycle the dryer off when the pre-programmed dryness level (1 to 99) or maximum cut-off time (Adrt) (1 to 99 minutes) has been reached, whichever comes first.

## ANTI-WRINKLE

This program helps keep permanent press items wrinkle free when they are not removed from the dryer promptly at the end of the drying and cooling cycle. The owner programs the dryer to automatically restart in the cool down cycle if the clothes are not removed in a pre-programmed amount of time. Anti-wrinkle program settings:

1. Guard Delay Time - 1 to 9 minutes
2. Guard On Time - 1 to 99 seconds
3. Active Guard Time - 1 to 99 minutes

## FREE-DRY MODE

In this program mode, the computer automatically reverts back to the automatic mode. However, no coins are required to start the dryer.

## L.E.D. FLASH DISPLAY

Programmable to allow L.E.D. readout to display a choice of "FILL" (no cycle in progress), "Amount to Start" (i.e. 25¢), or, in the case of free dry, "FrEE". Programming also allows the L.E.D. display to flash back and forth every two (2) seconds from "FILL" to "Amount to Start" or, in the case of free dry, from "FILL" to "FrEE".

## AUDIBLE TONE

A tone will sound for each coin inserted, program entry, or at the end of the drying cycle and cooling cycle for a period of five (5) seconds to indicate that the cycle is complete. In

addition, when in the anti-wrinkle program, the tone will sound for five (5) seconds at the end of the Guard On Time.

#### TEMPERATURE DISPLAY

This program selection enables the temperature in the dryer to be viewed (F. or C.) either while the dryer is off or running. This service feature shows that the dryer is maintaining the selected temperature.

#### DIAGNOSTICS

All major circuits, including door, micro-processor temperature sensor, heat and motor circuits, are monitored.

#### BATTERY BACKUP (OPTIONAL)

This feature allows the computer to maintain its operating status should a momentary power interruption occur while the dryer cycle is in progress.

## 2. L.E.D. Display and Codes

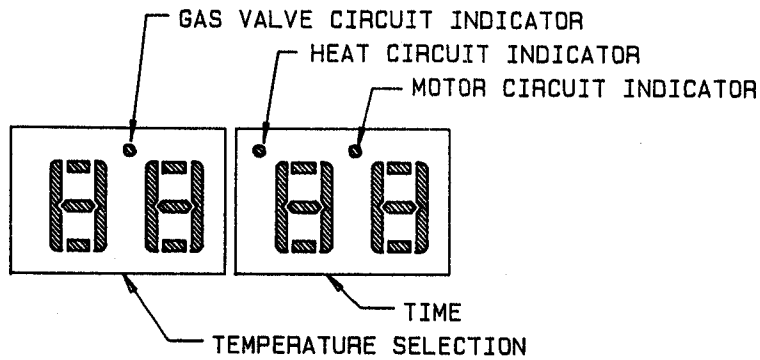

ACOn	Accumulative Coin
Adrt	Maximum Auto Dryness Time
AFAt	Amount for Additional Time
AGt	Active Anti-wrinkle Guard Time
AtIn	Accumulative Time
AtSt	Amount to Start
Aut0	Automatic Mode
bCLO	Bad Coin Lockout
bCrS	Bad Coin Reset
bUZ	Buzzer (Tone)
°CEL	Degree in Celsius
CLCC	Clear Left Coin Count
Coin	Coin Mode
CrCC	Clear Right Coin Count
donE	Drying and Cooling Cycles Complete
	or
	Dryer is in Anti-wrinkle Cycle
door	Door Circuit is Open
drYL	Dryness Level



dSFL	Dryer Sensor Circuit Failure
°FAr	Degree in Fahrenheit
FILL	No Cycle in Progress
FLS	Flash Display Active
FrEE	Free Dry Mode
GdLY	Anti-wrinkle Delay Time
Gont	Anti-wrinkle On Time
Grd	Anti-wrinkle Program Active
HICd	High Cool Down
LCC	Left Coin Count
LCdE	Left Coin Denomination
LOCd	Low Cool Down
nbUZ	No Buzzer (Tone)
nFLS	No Flash Display
nGrd	No Anti-wrinkle
OFF	Bad Coin Lockout Program Tripped
PL	Program Location
PPCd	Perm Press Cool Down
PUSH	Amount to Start has been Inserted . . . Make Temperature Selection
rCC	Right Coin Count
rCdE	Right Coin Denomination
tInE	Time Mode
tPLC	Time Per Left Coin

### 3. Operating Instructions

NOTE: Unless otherwise specified at the time of ordering, the Phase 3 computer has been pre-programmed by the factory with the parameters shown on pages 60 and 61. Should program changes be found necessary, please read this manual carefully to thoroughly familiarize yourself with the Phase 3 programming characteristics.

#### a. TIMED MODE

1. When turning on power or when no cycle is in progress, the L.E.D. display will read "FILL" and/or "Amount to Start".
2. Insert coin(s). Once correct "Amount to Start" has been inserted, display will read "PUSH".
3. Select temperature by pushing HI temp, LO temp, or Perm Press. The dryer will start, and the display will read the temperature cycle selected and the drying time.
4. The dryer will continue through the drying and cooling cycles, showing time counting downward.

NOTE: If the door is opened during a cycle, both the heat and motor will stop. However, the computer will continue to count down in time. Continuation of the cycle will resume only after the door has been closed and any one of the three (3) temperature selection buttons is again depressed.

5. Upon completion of drying and cooling cycles, the tone will sound, and the display will read "donE" for five (5) seconds, at which time the dryer will shut off.

NOTE: a. If the anti-wrinkle program is active, the display will remain reading "donE", and the computer will proceed through the anti-wrinkle program until the maximum Guard On Time has expired or until the door is opened, whichever comes first. The display will read "FILL" and/or "Amount to Start".

b. If the anti-wrinkle program is not active or in use, the display will read "FILL" and/or "Amount to Start".

#### b. AUTOMATIC MODE

1. When turning on power or when no cycle is in progress, the L.E.D. display will read "FILL" and/or "Amount to Start".

2. Insert coin(s). Once correct "Amount to Start" has been inserted, display will read "PUSH".
3. Select temperature by pushing HI temp, LO temp, or Perm Press. The dryer will start, the display will read the temperature cycle selected, and the drying time portion of the display will read "00" and count upward as time elapses.

NOTE: If the door is opened during a cycle, both the heat and motor will stop. However, the computer will continue to count up in time. Continuation of the cycle will resume only after the door has been closed and any one of the three (3) temperature selection buttons is again depressed.

4. Once the pre-programmed dryness level and cool down period have been reached or maximum automatic time has expired, whichever comes first, the tone will sound, and the display will read "donE" for five (5) seconds, at which time the dryer will shut off.

NOTE: a. If the anti-wrinkle program is active, the display will continue to read "donE", and the computer will proceed through the anti-wrinkle program until the maximum Guard On Time has expired or until the door is opened, whichever comes first. The display will read "FILL" and/or "Amount to Start".

b. If the anti-wrinkle program is not active or in use, the display will read "FILL" and/or "Amount to Start".

c. FREE DRY MODE

1. When turning on power or when no cycle is in progress, the L.E.D. display will read "FILL" and/or "FrEE".
2. Select temperature. The dryer will start, the display will read the temperature cycle selected, and the drying time portion of the display will read "00" and count upward as time elapses.

NOTE: If the door is opened during a cycle, both the heat and motor will stop. However, the computer will continue to count up in time. Continuation of the cycle will resume only after the door has been closed, and one of the three temperature selection buttons is again depressed.

3. Once the pre-programmed dryness level and cool down

period has been reached or maximum automatic time has expired, whichever comes first, the tone will sound, and the display will read "donE" for five (5) seconds, at which time the dryer will shut off.

NOTE: a. If the anti-wrinkle program is active, the display will continue to read "donE", and the computer will proceed through the anti-wrinkle program until the maximum Guard On Time has expired or until the door is opened, whichever comes first. The display will read "FILL" and/or "FrEE".

b. If the anti-wrinkle program is not active or in use, the display will read "FILL" and/or "FrEE".

#### 4. Program Selections

NOTE: Programs are stored in the computer memory and are cataloged as program locations (PL).

#### TEMPERATURE DISPLAY MODE

By closing the Program Switch (PS), the display will read the temperature in the dryer in either Fahrenheit or Celsius, depending on how the PL01 temperature conversion status is set. The temperature display mode can be activated while the dryer is in the operating cycle or off. While in the operating cycle, the circuit indicators are visible for trouble shooting purposes.

NOTE: The dryer cannot be started while the computer program switch (PS) is closed unless the cycle was already in progress.

#### RIGHT COIN COUNT (rCC)

For models equipped with the optional dual coin acceptor, by closing the program switch and pushing the "HI temp" keyboard selection button, the amount of coins inserted through the right coin slot of the coin acceptor can be viewed through the L.E.D. display. The computer memory will retain a running count of up to 9999 coins and can be cleared (CrCC) by following the procedure shown on page 39.

#### LEFT COIN COUNT (LCC)

The number of coins inserted for a single coin acceptor dryer or in the case of a dual coin acceptor, the left coin slot can be viewed through the L.E.D. display by closing the program

switch and pushing the "LO temp" keyboard selection button. The computer memory will retain a running count of up to 9999 coins and can be cleared (CLCC) by following the procedure shown on page 40.

### PL01 - TEMPERATURE CONVERSION STATUS

This program controls whether the temperature-related programs will be operated in Fahrenheit or Celsius. Programs affected are:

1. Temperature display mode
2. Selection cycling temperatures
3. Cool down temperatures

### AUTOMATIC MODE (AUt0)

When this program is selected (AUt0), the dryer will run for a pre-set level of dryness (PL02) or until the programmed automatic maximum time (PL14) has expired.

At the end of the drying cycle, the dryer will go into the cool down cycle for the time period programmed (PL04, PL06, or PL08) or until the temperature has dropped to the programmed cool down temperature (PL04, PL06, or PL08).

NOTE: Due to humidity, atmospheric pressure, percentage of extraction, etc., the desired dryness level may vary. It is suggested that the owner determine which level of dryness is best suited for his application by experimenting with a few test loads.

### TIME MODE (tInE)

When this program is selected (tInE) and the computer has been activated by the insertion of a coin(s), the dryer will continue to run until the pre-set time including the cool down period (PL04, PL06, or PL08) has elapsed, at which time the dryer will cycle off or go into the optional anti-wrinkle program.

### ANTI-WRINKLE PROGRAM (Grd)

This feature can be used in conjunction with any of the three operating modes - coin, automatic, or free dry. In this program, when the drying and cooling cycles are completed, the dryer will shut off, the tone will sound, and the L.E.D. display

will read "donE". If the door is not opened, the computer will wait until the Guard Delay Time (PL15) has expired, at which time the clothes will be tumbled (without heat) for the programmed Guard On Time (PL15). The computer will repeat this process until the programmed Active Guard Time (PL16) has expired or until the dryer door is opened, at which time the L.E.D. display will read "FILL" and "Amount to Start", or "FILL" and "FrEE".

#### BUZ/TONE (bUZ)

When in the anti-wrinkle program, the option is available to have the tone sound for a period of five (5) seconds at the end of each Guard On Time cycle.

#### FREE DRY MODE (FrEE)

The computer can be programmed to run without the insertion of coins. When the computer is programmed in the free dry mode, it automatically reverts to the automatic cycle (AUt0).

#### COIN MODE (Coin)

In this program, coins are required to start the dryer, even if the computer is set in the automatic mode.

#### FLASH DISPLAY STATUS (FLS)

When the computer is set in this program status, it allows the L.E.D. readout to display a choice of "FILL" (no cycle in progress), "Amount to Start" (PL12), or in the case of free dry, "FrEE". Programming allows the L.E.D. readout to revert back and forth every two (2) seconds from "FILL" to "Amount to Start", or in the case of free dry, from "FILL" to "FrEE".

#### BAD COIN LOCKOUT STATUS (bCLO)

In this program status the computer counts in milliseconds the amount of time required for a coin entry signal. If someone should tamper with the coin acceptor or attempt a foreign object entry, the computer will lock up, shut the dryer down, and the display will read "OFF". This condition will be evident, even if coins are inserted, until the program is manually reset by closing and re-opening the program switch (PS).

#### BAD COIN LOCKOUT RESET (bCrS)

When set in this program status, the computer counts in

milliseconds the amount of time required for a coin entry signal. If someone should tamper with the coin acceptor or attempt a foreign object entry, the computer will not accept the entry and will automatically reset itself for the next entry.

ACCUMULATIVE TIME (AtIn)

(SINGLE COIN) See below for dual coin.

In this program mode, each coin inserted has a specific value of time which is determined by the Time Per Left Coin (tPLC) (PL11) program.

Example No. 1: If the dryer is equipped with a 25¢ coin acceptor and the desired time is 12 minutes, each additional coin inserted would yield 12 minutes.

Settings: PL09 (LCdE) - 25  
PL11 (tPLC) - 12  
PL12 (AtSt) - 25

Example No. 2: If the dryer is equipped with a 25¢ coin acceptor and the "Amount to Start" (AtSt) is 50¢ for 30 minutes, the insertion of each additional coin would yield 15 minutes. In this application the "Time Per Left Coin" (tPLC) is determined by dividing the "Total Vend Time" (30) by the "Amount to Start" (AtSt) (i.e. 50¢) and then, multiplying by the Left Coin Denomination (LCdE).

Formula:  $\frac{\text{Total Vend Time} \times \text{LCdE}}{\text{AtSt}} = \text{tPLC}$

$$\frac{30 \times 25}{50} = 15 \text{ Minutes (tPLC)}$$

Settings: PL09 (LCdE) - 25  
PL11 (tPLC) - 15  
PL12 (AtSt) - 50

(DUAL COIN)

In the time accumulation mode, when using a dual coin acceptor, once the Amount to Start (AtSt) has been inserted, the

addition of a coin(s) yields more time. The amount of time accumulated for each additional coin inserted is determined by the Time Per Left Coin program (tPLC) (PL11).

The Time Per Left Coin (tPLC) is determined by taking the Total Vend Time divided by the Amount to Start (AtSt) (PL12) and then, multiplying by the Left Coin Denomination (LCdE).

$$\text{Formula: } \frac{\text{Total Vend Time}}{\text{AtSt}} \times \text{LCdE} = \text{tPLC}$$

Example No. 1: Using a 10¢/25¢ dual coin acceptor with the desired Amount to Start (AtSt) being 25¢ for 15 minutes, each additional 10¢ inserted would yield 6 minutes.

$$\text{Formula: } \frac{15}{25} \times 10 = 6 \text{ Minutes (tPLC)}$$

Settings: PL09 (LCdE) - 10  
PL10 (rCdE) - 25  
PL11 (tPLC) - 6  
PL12 (AtSt) - 25

Example No. 2: If the dryer is equipped with a 10¢/25¢ acceptor and the Amount to Start (AtSt) is 35¢ for 14 minutes, each additional 10¢ inserted would yield 4 minutes, or each additional 25¢ yields 10 minutes.

$$\text{Formula: } \frac{14}{35} \times 10 = 4 \text{ Minutes (tPLC)}$$

Settings: PL09 (LCdE) - 10  
PL10 (rCdE) - 25  
PL11 (tPLC) - 4  
PL12 (AtSt) - 35

Example No. 3: If the dryer is equipped with a 10¢/25¢ acceptor and the desired Amount to Start (AtSt) is 55¢ for 33 minutes, each additional 10¢ inserted would yield 6 minutes, and each 25¢, an additional 15 minutes.



Formula:  $\frac{33}{55} \times 10 = 6 \text{ Minutes (tPLC)}$

Settings: PL09 (LCdE) - 10  
PL10 (rCdE) - 25  
PL11 (tPLC) - 6  
PL12 (AtSt) - 55

NOTE: If the Total Vend Time cannot be divided evenly by the Amount to Start, the Time Per Left Coin must be rounded off.

Example:  $\frac{35}{55} \times 10 = 6.36 - \text{Round off to 6 minutes.}$

#### ACCUMULATIVE COIN (ACOn)

When this program mode is selected, additional time can only be achieved when the Amount for Additional Time (PL13) has been inserted.

#### (SINGLE COIN ACCEPTOR)

Example No. 1: Using a 25¢ coin acceptor with the desired Amount to Start (AtSt) being 50¢ for 24 minutes, the computer would yield more time (24 minutes) only when an additional 50¢ is inserted. For this application, the Time per Left Coin (PL11) is determined as illustrated above.

Formula:  $\frac{\text{Total Vend Time} \times \text{LCdE}}{\text{AtSt}} = \text{tPLC}$

Example:  $\frac{24}{50} \times 25 = 12 \text{ Minutes (tPLC)}$

Settings: PL09 (LCdE) - 25  
PL11 (tPLC) - 12  
PL12 (AtSt) - 50  
PL13 (AFAt) - 50

#### (DUAL COIN ACCEPTOR)

With a dual coin acceptor the Time Per Left Coin is determined as illustrated above.

Formula:  $\frac{\text{Total Vend Time}}{\text{AtSt}} \times \text{LCdE} = \text{tPLC}$

Example No. 1: When using a 10¢/25¢ dual coin acceptor and the desired Amount to Start (AtSt) is 50¢ for 20 minutes and the Amount for Additional Time is set for 20¢, each additional 20¢ inserted would yield 8 minutes.

Formula:  $\frac{20}{50} \times 10 = 4 \text{ Minutes (tPLC)}$

Settings: PL09 (LCdE) - 10  
PL10 (rCdE) - 25  
PL11 (tPLC) - 4  
PL12 (AtSt) - 50  
PL13 (AFAt) - 20

Example No. 2: If the dryer is equipped with a 10¢/25¢ dual coin acceptor and the Amount to Start (AtSt) is 35¢ for 14 minutes and the Amount for Additional Time is set for 25¢, each additional 25¢ inserted would yield 10 minutes.

Formula:  $\frac{14}{35} \times 10 = 4 \text{ minutes (tPLC)}$

Settings: PL09 (LCdE) - 10  
PL10 (rCdE) - 25  
PL11 (tPLC) - 4  
PL12 (AtSt) - 35  
PL13 (AFAt) - 25

#### PL02 - DRYNESS LEVEL (drYL)

When in the automatic or free dry mode, the dryer will run until the pre-set level of dryness (Number of Auto Peaks) has been reached. The dryness level is programmable from a minimum of 1 to a maximum of 99.

NOTE: Due to humidity, atmospheric pressure, water retention in garment, etc., the desired dryness level may vary. It is suggested that the owner determine which level of dryness is best

suited for his application by experimenting with a few test loads.

PL03 - HIGH TEMPERATURE (HI°F)

The high operating temperature is programmable from a minimum of 100° F. to a maximum of 190° F. in 10° increments or from a minimum of 35° C. to a maximum of 90° C in 5° increments.

PL04 - HIGH COOL DOWN TEMPERATURE/TIME (HICd)

The first part of this program controls the cool down temperature when the computer is used in the automatic or free dry mode. The cool down temperature is programmable from a minimum of 100° F. to a maximum of 190° F. in 10° increments or from a minimum of 35° C. to a maximum of 90° C. in 5° increments.

The second part of this program controls the cool down time for both the automatic and timed modes. The cool down time can be programmed from a minimum of 0 to a maximum of 9 minutes.

NOTE: When the computer is used in the automatic or free dry mode, at the end of the drying cycle, the computer then starts the automatic cooling cycle for the cool down time programmed or until the temperature has dropped to the programmed cool down temperature, whichever of the two comes first.

PL05 - LOW TEMPERATURE (LO°F)

Same as PL03 but for Low Temperature program.

PL06 - LOW COOL DOWN TEMPERATURE/TIME (LOCd)

Same as PL04 but for Low Cool Down Temperature/Time.

PL07 - PERMANENT PRESS (PP°F)

Same as PL03 but for Perm Press.

PL08 - PERMANENT PRESS COOL DOWN TEMPERATURE/TIME (PPCd)

Same as PL04 but for Perm Press Cool Down Temperature/Time.

### PL09 - LEFT COIN DENOMINATION (LCdE)

In the case of a single coin acceptor, this program setting is determined by the value of the coin acceptor (i.e. 25¢).

When a dual coin acceptor is used, this program setting is determined by the left coin slot coin acceptor value (lower coin value).

Program settings are from a minimum of 1 to a maximum of 9999.

### PL10 - RIGHT COIN DENOMINATION (rCdE)

This program need only be set when a dual coin acceptor is used. The program setting is determined by the value of the right coin acceptor slot (higher value).

Program settings are from a minimum of 1 to a maximum of 9999.

When used in conjunction with the Left Coin Slot Denomination program, the computer automatically calculates the ratios necessary for coin insertion time values.

### PL11 - TIME PER LEFT COIN (tPLC)

This program sets a specific value of time for each coin inserted. In the case of a dual coin acceptor, the Time Per Right Coin is automatically calculated by the left and right coin slot denomination ratio.

### PL12 - AMOUNT TO START (AtSt)

This program sets the amount needed to start the dryer and can be programmed from a minimum of 1 to a maximum of 9999.

### PL13 - MINIMUM AMOUNT FOR MORE TIME (AFAt)

This program need only be set when the computer is set in the Coin Accumulation mode (ACOn) (PL01). The value set for this program is what will have to be inserted for more time after the Amount to Start has been inserted.

Example No. 1: Amount to Start (AtSt) is 50¢ for 30 minutes, and an additional 50¢ is required for more time.

In this example PL13 should be set for 50¢.

#### PL14 - MAXIMUM TIME FOR AUTOMATIC DRY (Adrt)

This program is used only when the computer is set in the automatic or free dry mode. This program controls the maximum time the dryer will run even if the Dryness Level program (PL02) has not been reached.

#### PL15 - ANTI-WRINKLE TIMING

##### 1. GUARD DELAY TIME (GdLY)

This program controls the dwell (stop) time and activation of the anti-wrinkle Guard On Time. The dwell time can be programmed from a minimum of 1 minute to a maximum of 9 minutes in 1-minute increments.

##### 2. GUARD ON TIME (Gont)

This setting controls the amount of time that the tumbler will turn without heat when anti-wrinkle is selected. The on time is programmable from a minimum of 1 to a maximum of 99 seconds in 1-second increments.

#### PL16 - ACTIVE GUARD TIME (AGt)

This program controls the maximum time that the anti-wrinkle cycle will be in progress and is programmable from a minimum of 1 minute to a maximum of 99 minutes in 1-minute increments.

## 5. Introduction to Programming

All programming is done through the keyboard selection buttons on the front of the control panel. To change programs or to put the computer in the temperature or coin count display modes, the program switch (PS) located on the back side of the computer must be put into the closed position (PSC).

The following instructions explain how to enter the program locations:

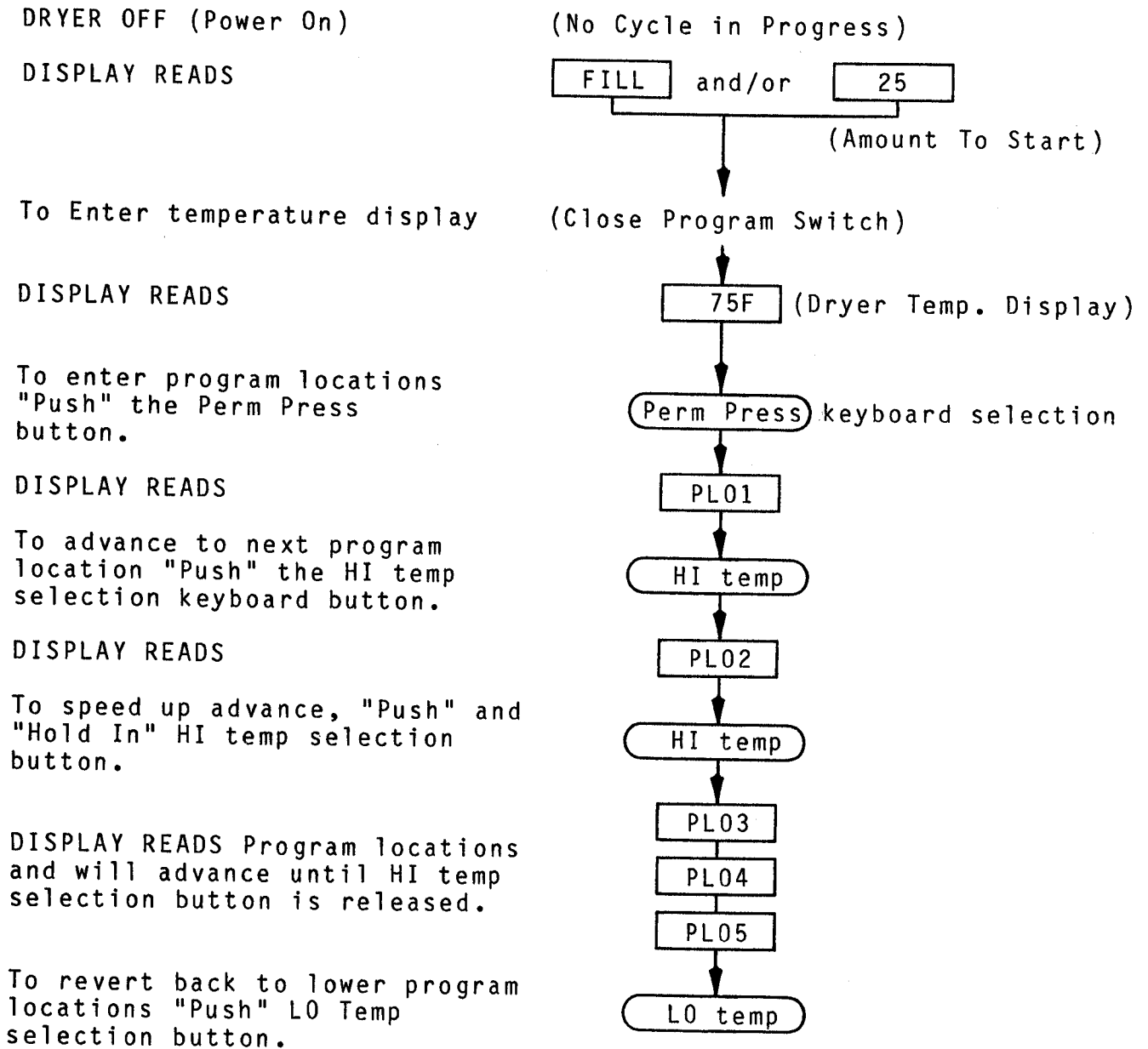

## DISPLAY READS

To speed up "Push" and "Hold In" LO temp selection button.

Display reads program locations and will advance downward until LO temp selection button is released.

To enter a specific program location (i.e. PL01) "Push" the Perm Press selection button.

DISPLAY WILL READ specific program location called up.

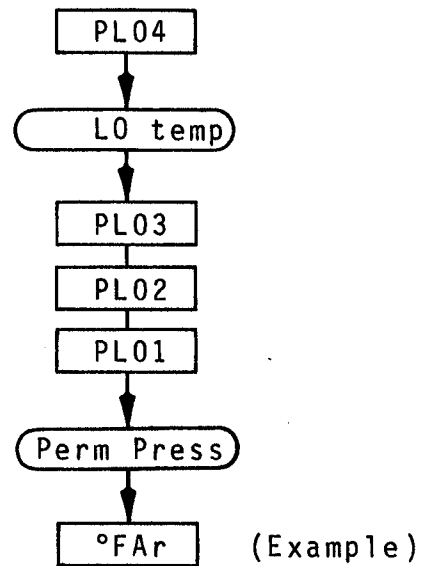

6. Programming

a. TEMPERATURE DISPLAY MODE

(No Cycle in Progress)

FILL and/or 25 (Amount to Start)

(Close Program Switch)

75F (Dryer Temperature Display)

(Cycle in Progress)

H<sup>.</sup>I<sup>.</sup>2<sup>.</sup>0 (Temperature Selection/Time)

(Close Program Switch)

1<sup>.</sup>3<sup>.</sup>5<sup>.</sup>F (Dryer Temperature Display)

(Open Tumbler Door - Dryer Shuts Off)

135F

(Close Door - Open Program Switch)

HI temp or LO temp or Perm Press

L<sup>.</sup>0<sup>.</sup>2<sup>.</sup>0 (Cycle Continues)



b. RIGHT COIN COUNT

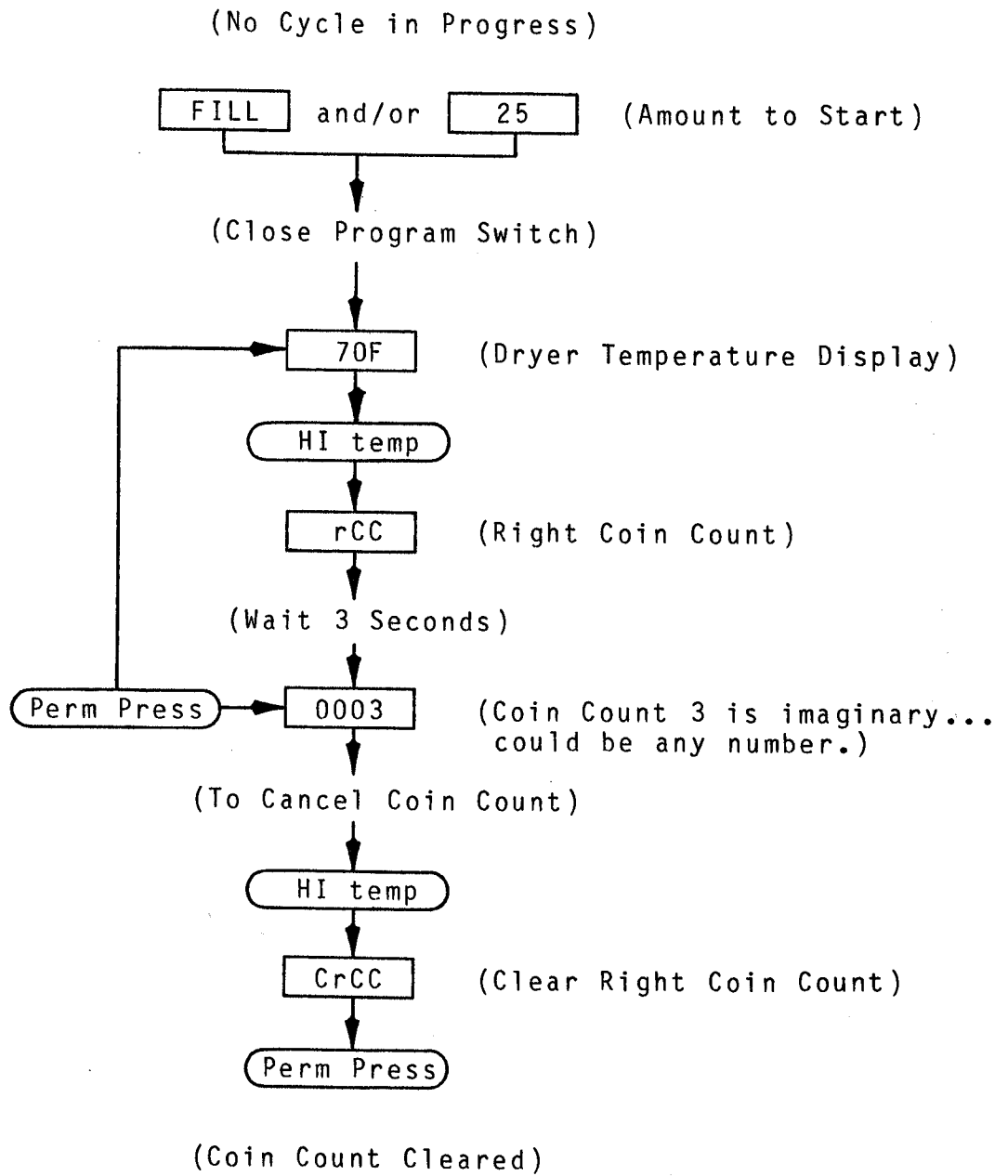

(Open program switch to exit out of display mode)

c. LEFT COIN COUNT

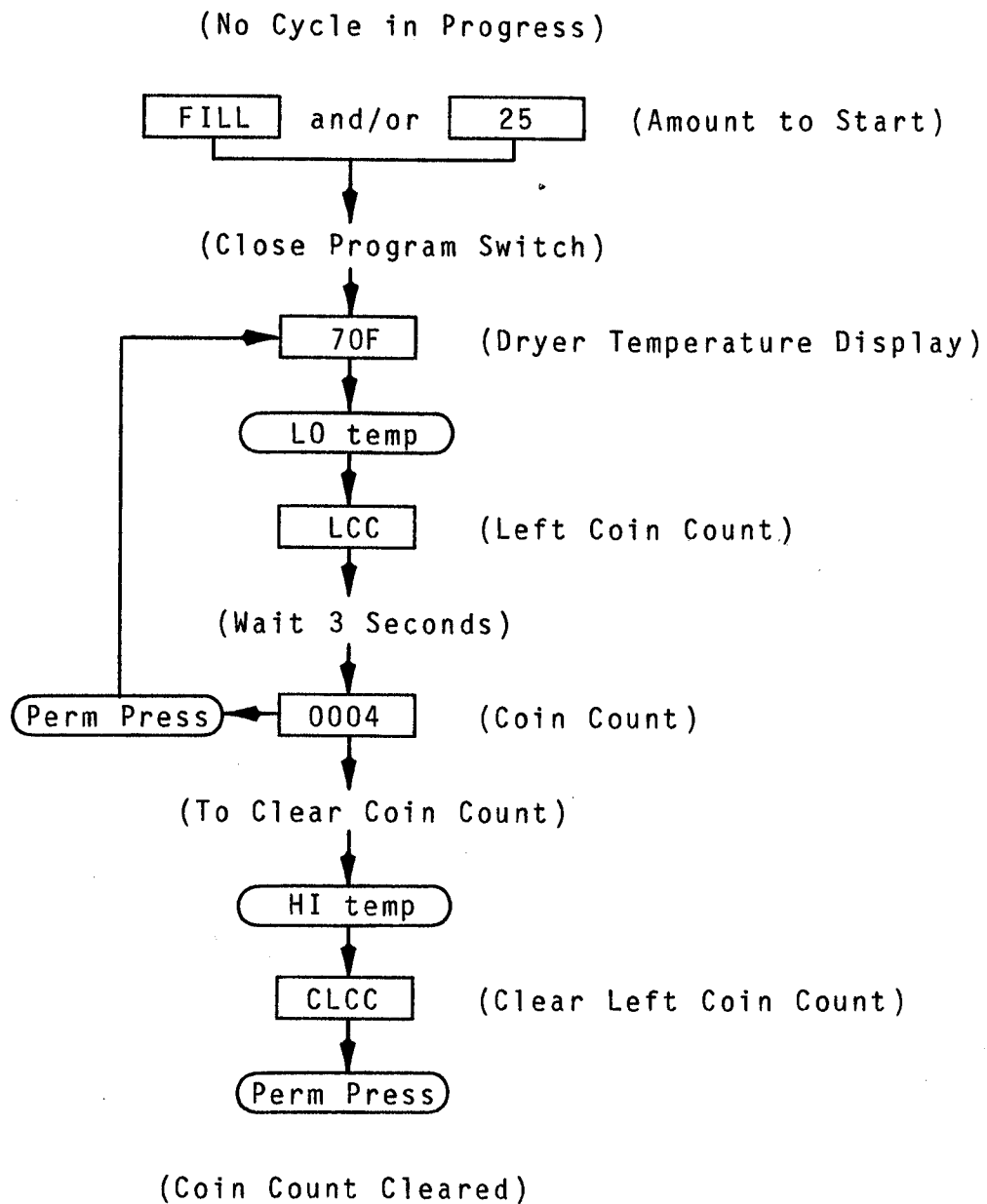

(Open program switch to exit out of display mode)

d. PROGRAM LOCATION 01 (PL01)

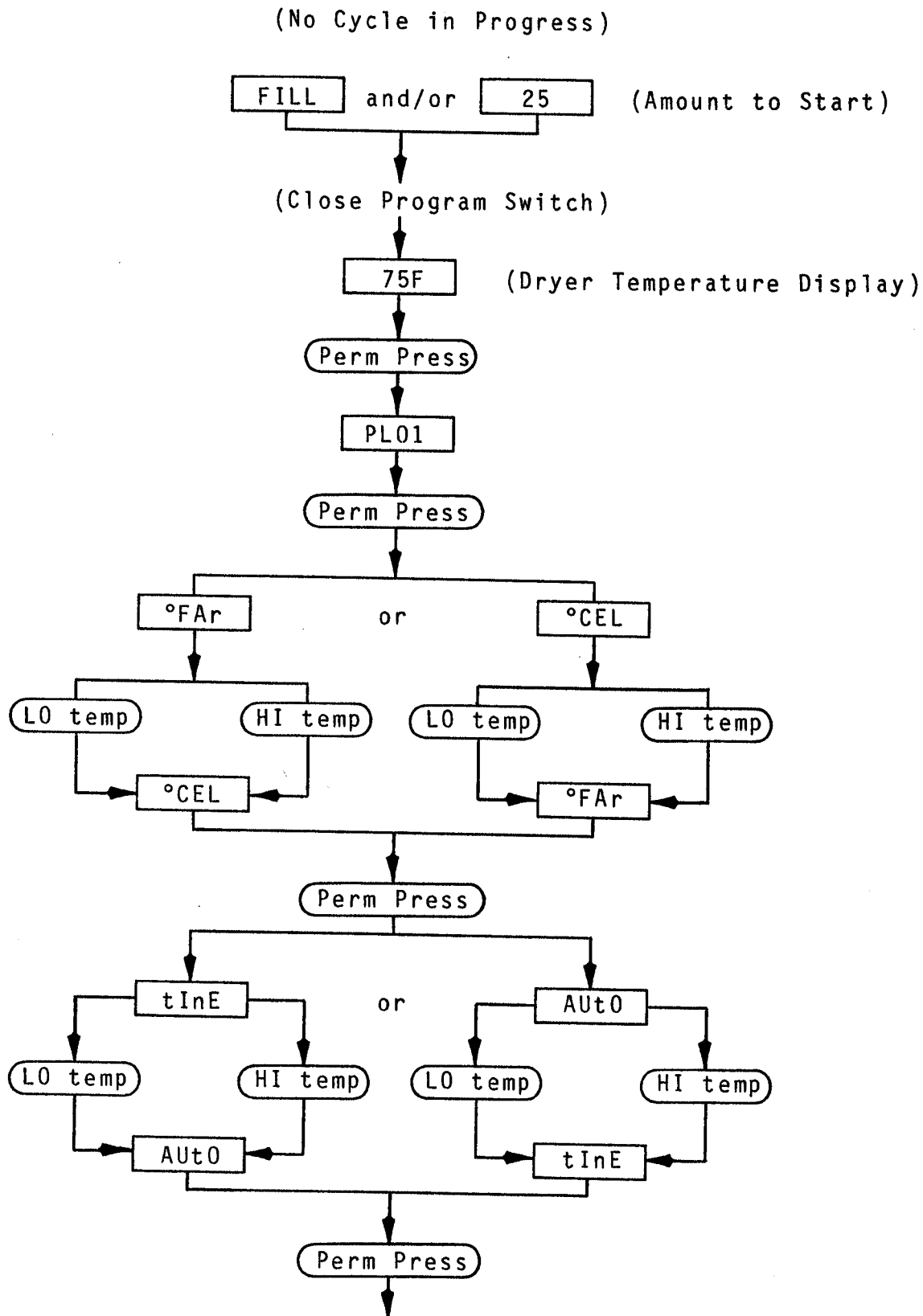

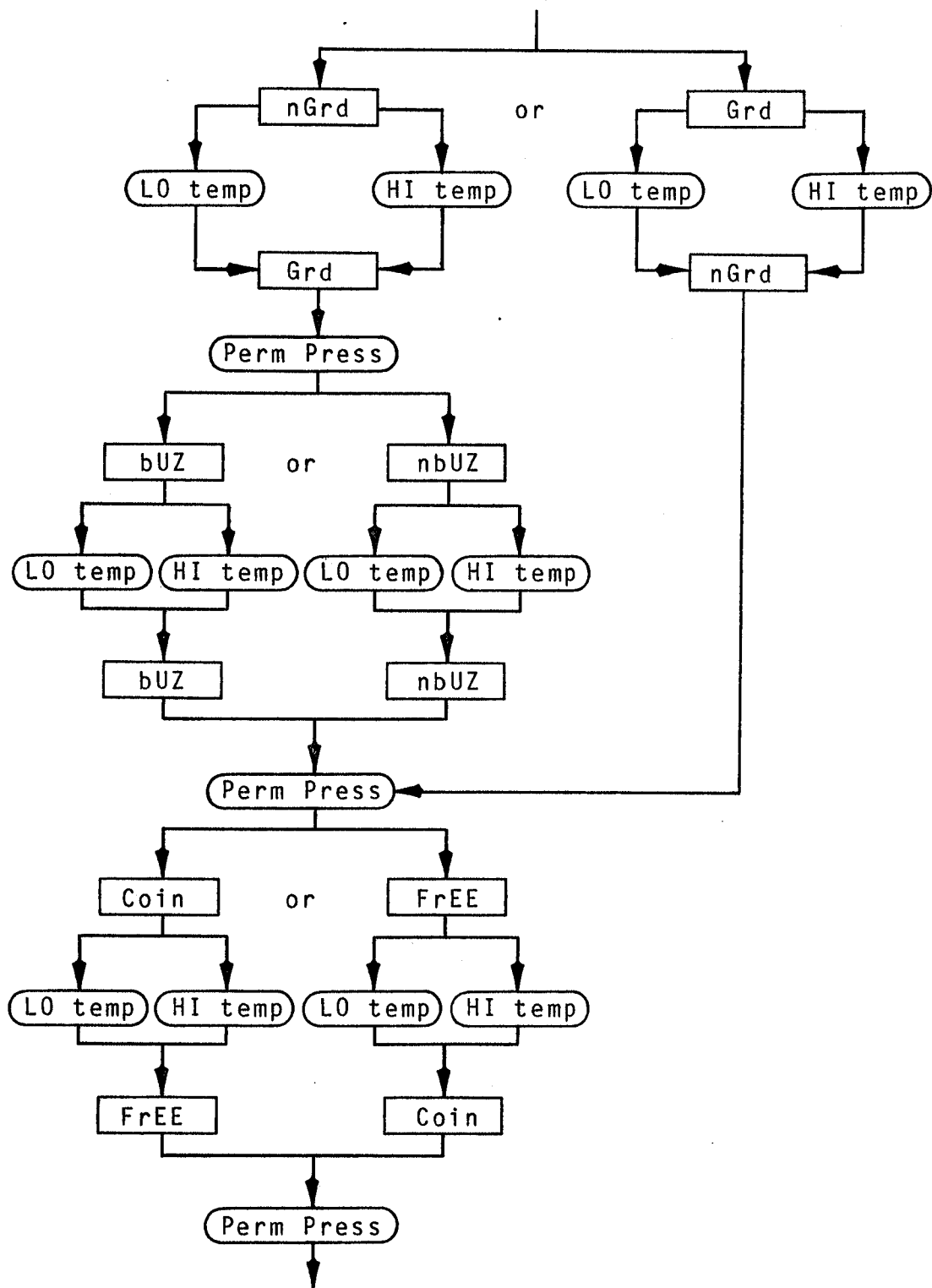

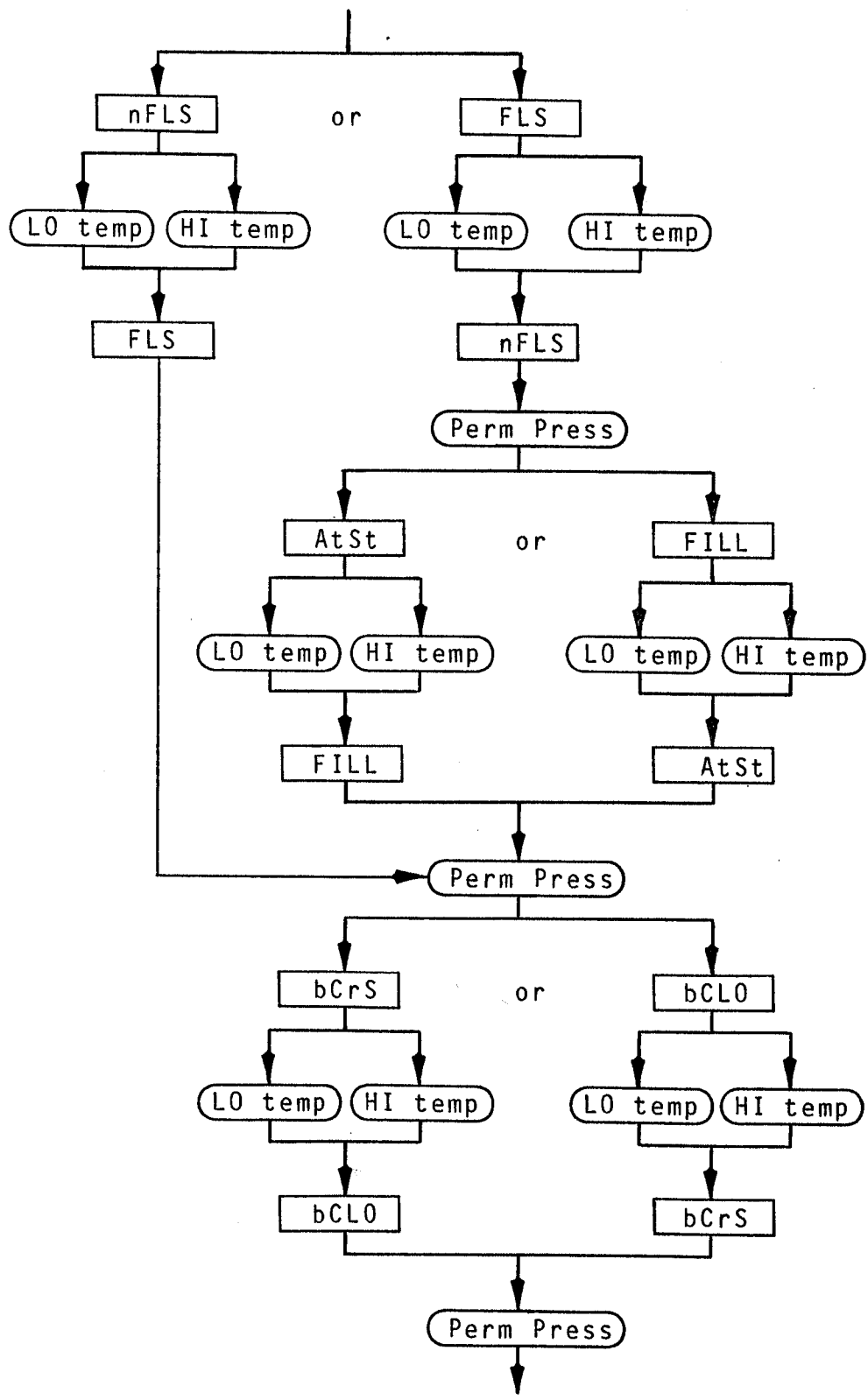

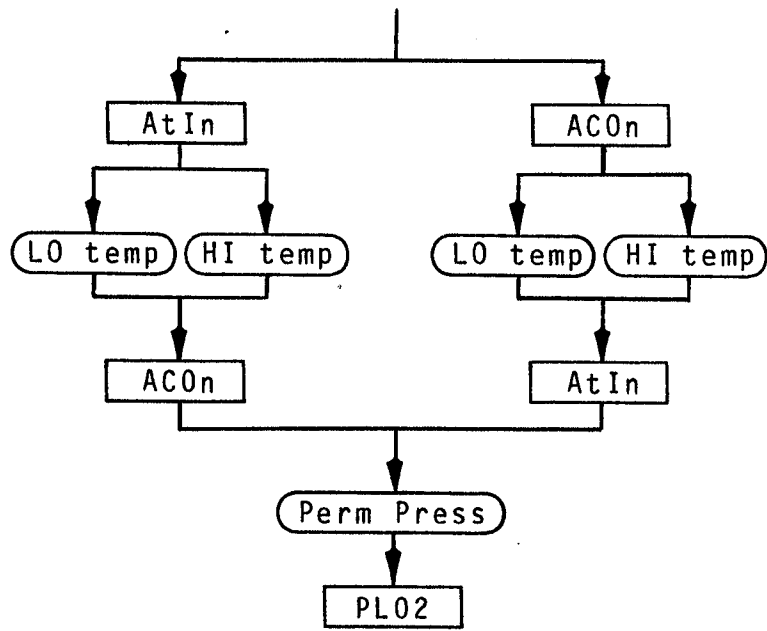

e. PROGRAM LOCATION 02 (PL02)

Number of Auto Peaks (Dryness Level)

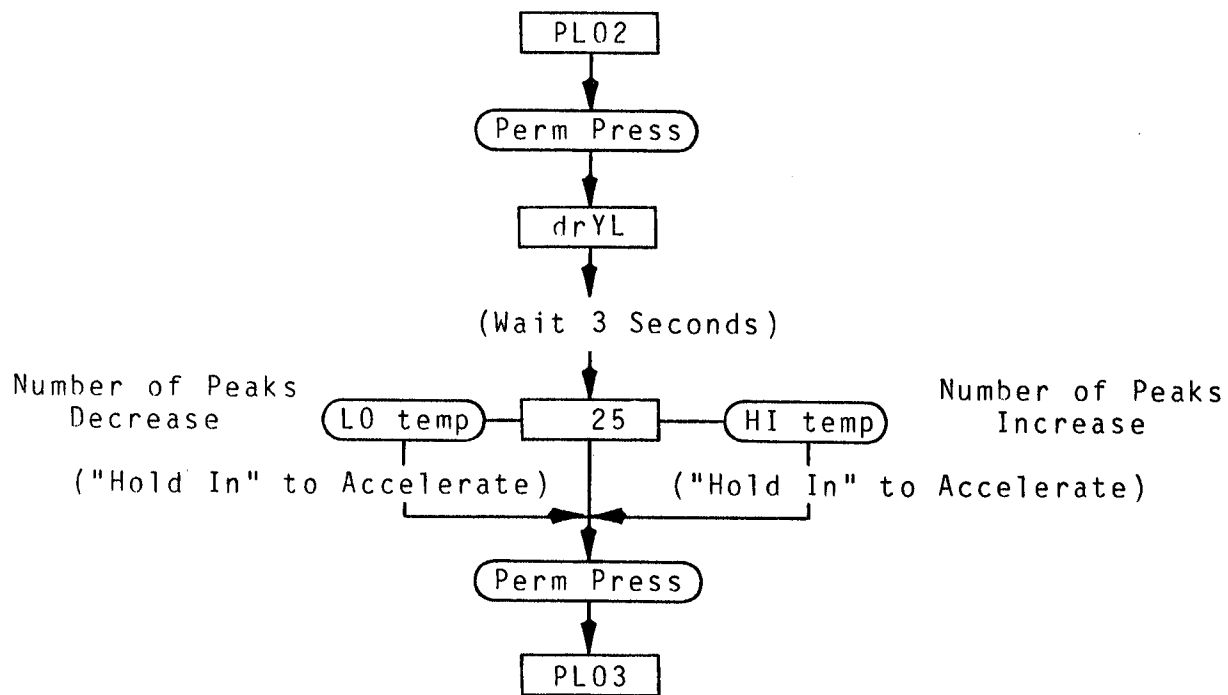

Summary: The dryness level is programmable from a minimum of 1 to a maximum of 99.

f. PROGRAM LOCATION 03 (PL03)

HI temp

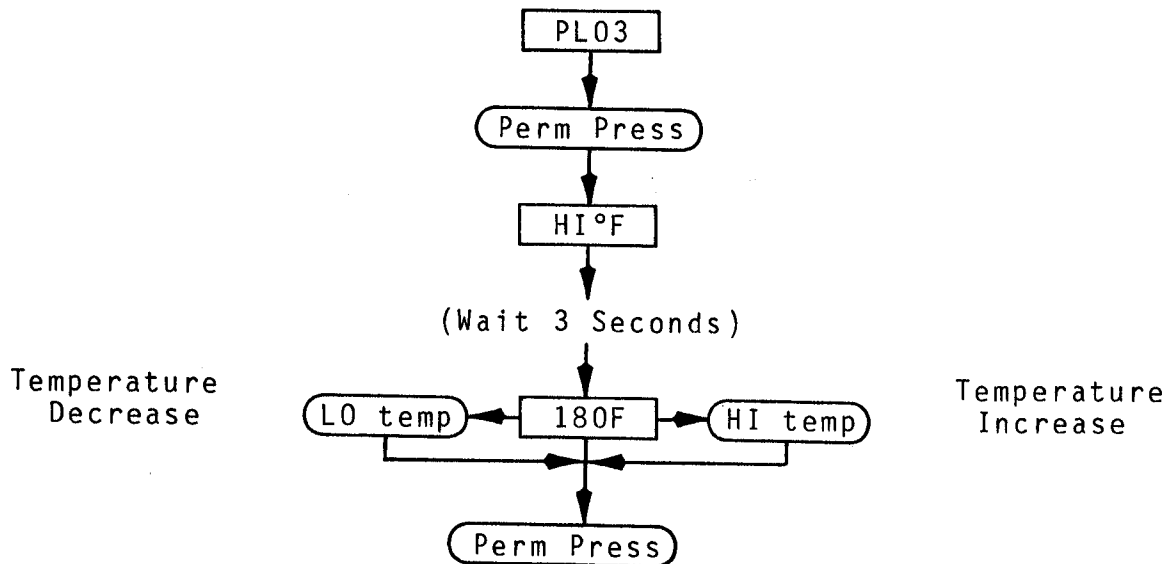

(Automatically Goes into PL04 Program without PL04 Display Mode)

Summary: HI temp is programmable from a minimum of 100° F. to a maximum of 190° F. in 10° increments or from a minimum of 35° C. to a maximum of 90° C. in 5° increments.



g. PROGRAM LOCATION 04 (PL04)

HI temp Cool Down Temperature/Time

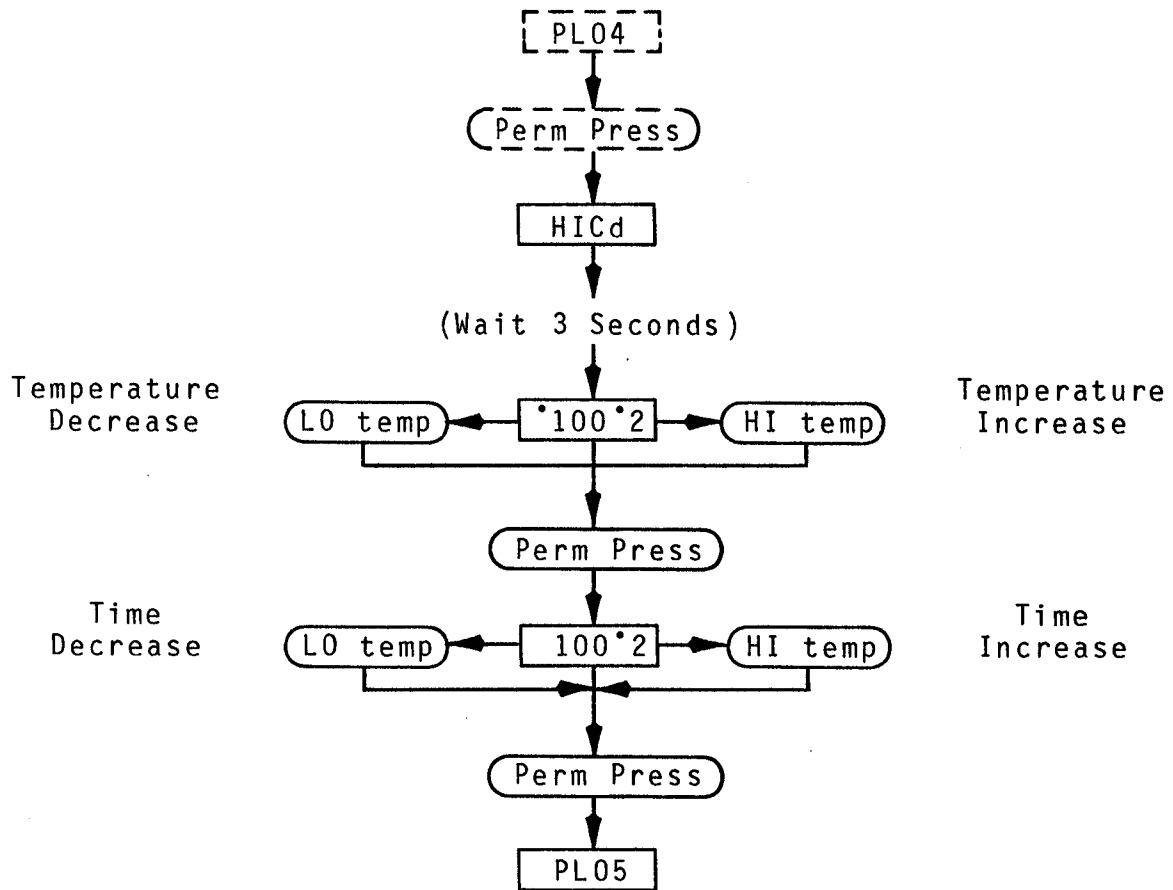

Summary: Cool down temperature is programmable from a minimum of 100° F. to a maximum of 190° F. or from 35° C. to a maximum of 90° C.

Cool down time is programmable from 0 to 9 minutes.

h. PROGRAM LOCATION 05 (PL05)

L0 temp

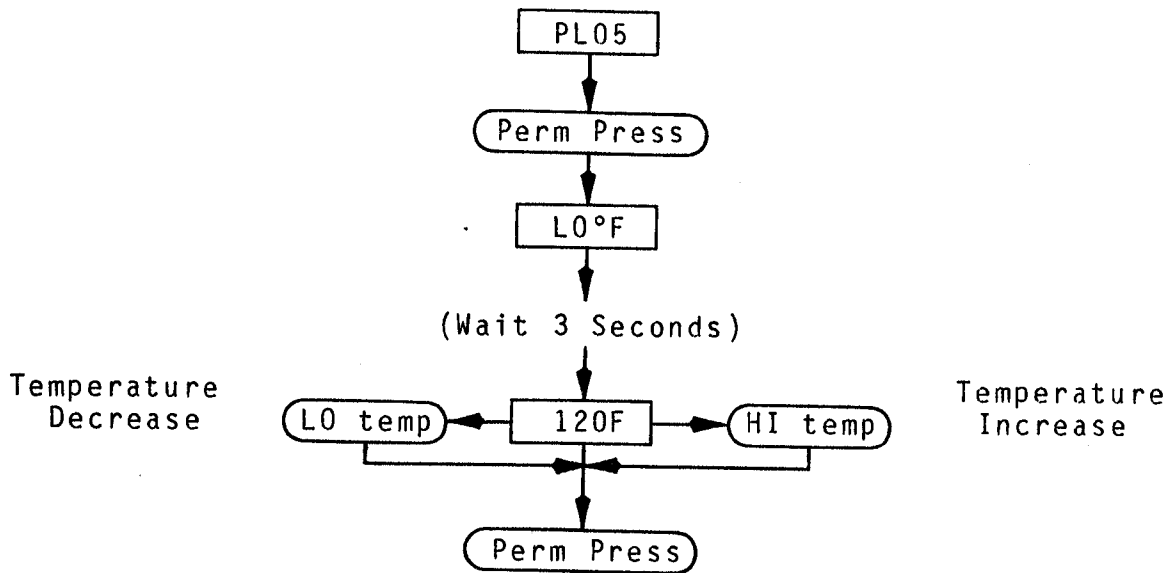

(Automatically goes into PL06 Program without PL06 Display Mode)

Summary: L0 temp is programmable from a minimum of 100° F. to a maximum of 190° F. in 10° increments or from a minimum of 35° C. to a maximum of 90° C. in 5° increments.

i. PROGRAM LOCATION 06 (PL06)

LO temp Cool Down Temperature/Time

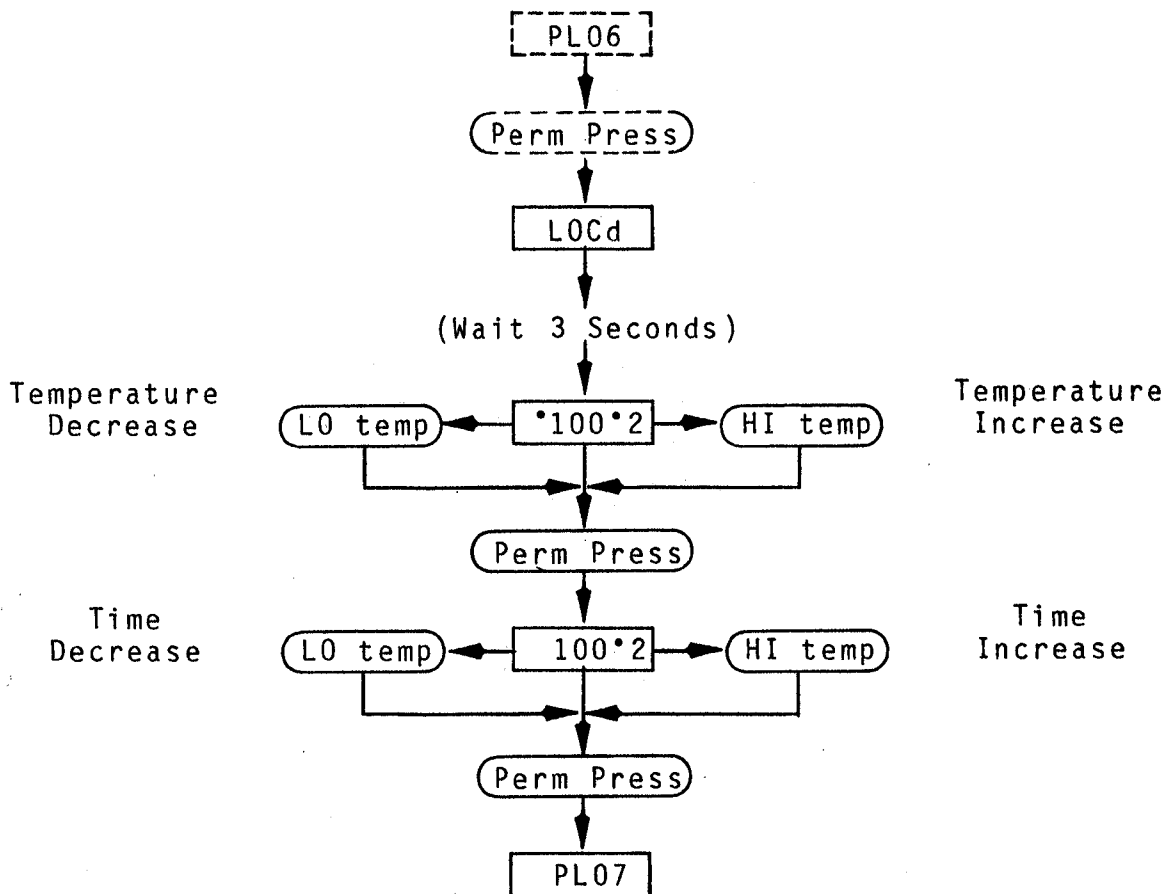

Summary: Cool down temperature is programmable from a minimum of 100° F. to a maximum of 190° F. or from 35° C. to a maximum of 90° C.

Cool down time is programmable from 0 to 9 minutes.

j. PROGRAM LOCATION 07 (PL07)

Perm Press Temperature

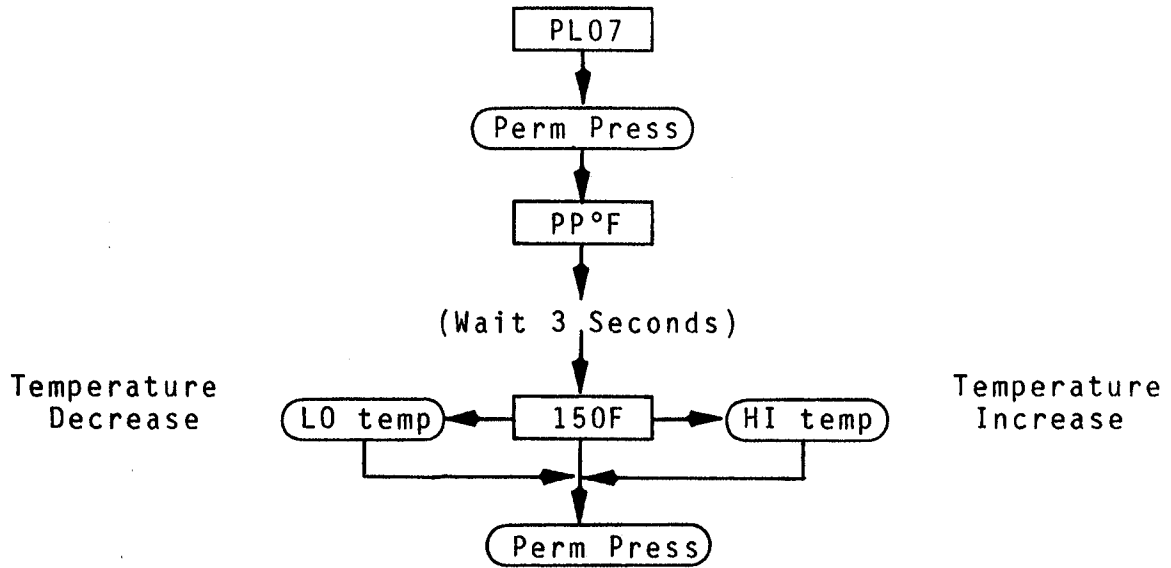

(Automatically Goes into PL08 Program  
without PL08 Display Mode)

Summary: Perm Press is programmable from a minimum of 100° F. to a maximum of 190° F. in 10° increments or from a minimum of 35° C. to a maximum of 90° C. in 5° increments.

k. PROGRAM LOCATION 08 (PL08)

Perm Press Cool Down Temperature/Time

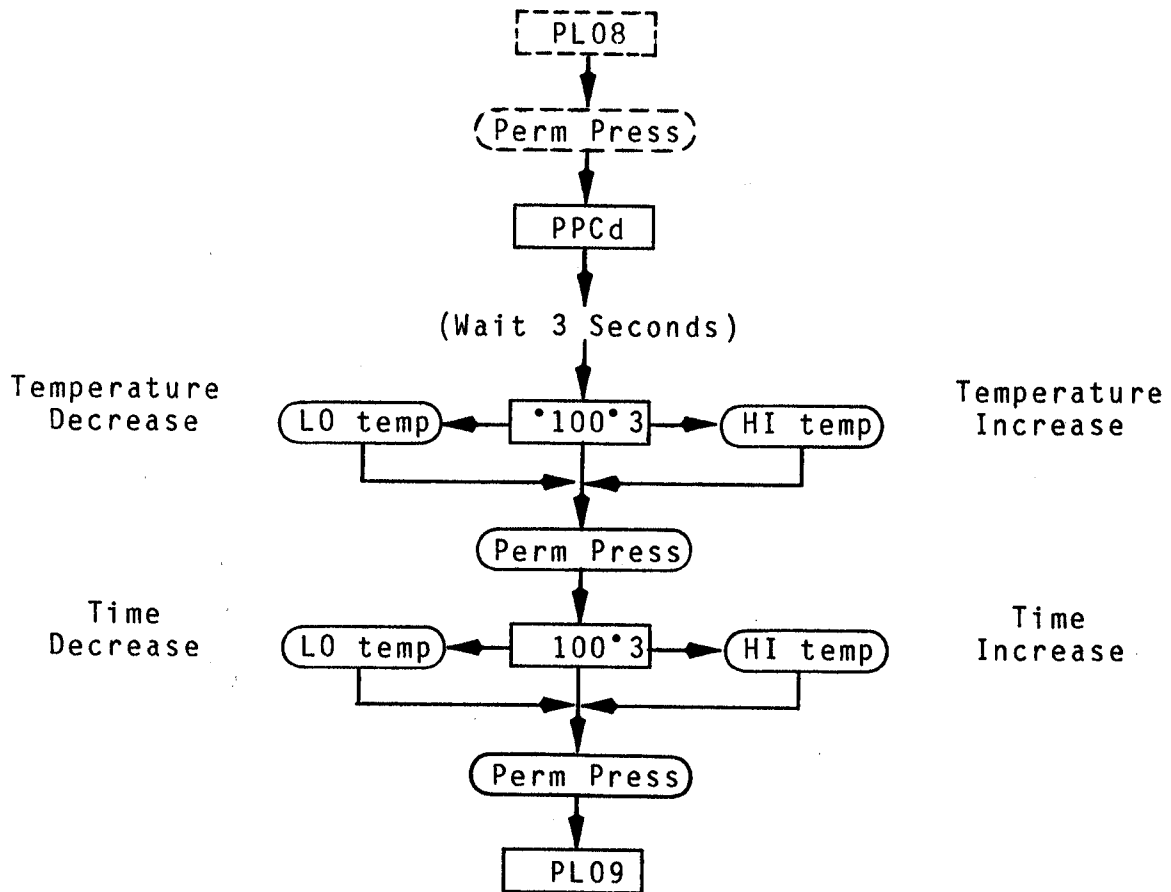

Summary: Cool down temperature is programmable from a minimum of 100° F. to a maximum of 190° F. or from 35° C to a maximum of 90° C.

Cool down time is programmable from 0 to 9 minutes.

1. PROGRAM LOCATION 09 (PL09)

Left Coin Denomination

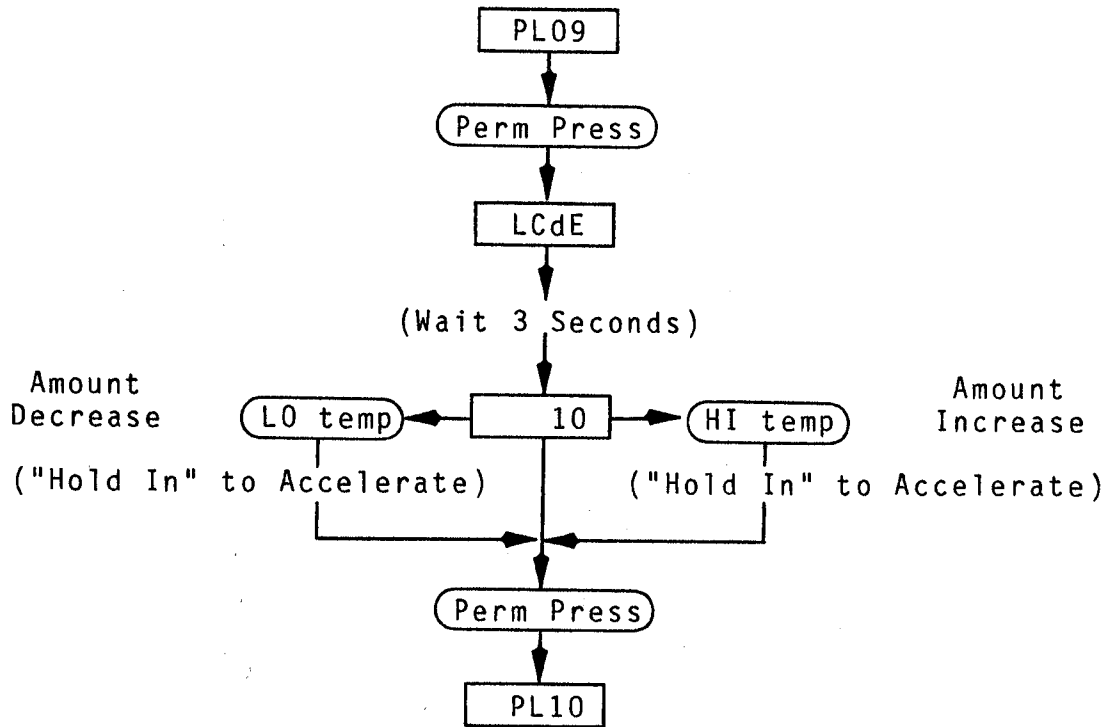

Summary: The left coin denomination is programmable from 1 to 9999.

m. PROGRAM LOCATION 10 (PL10)

Right Coin Denomination

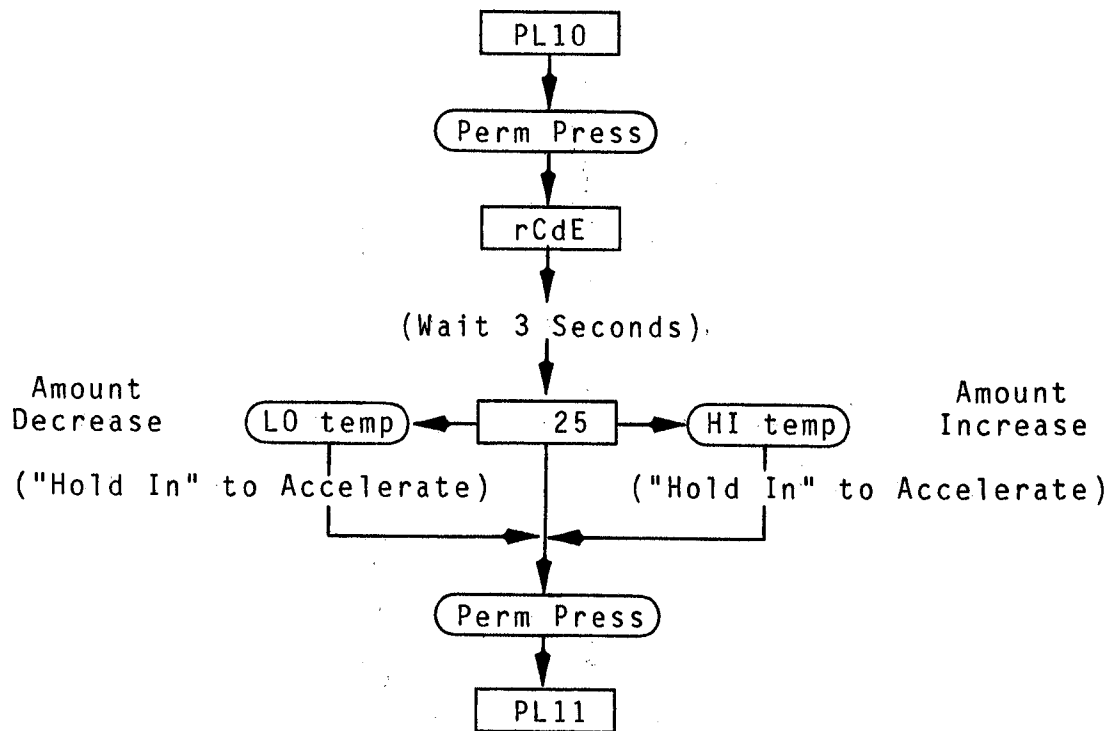

Summary: The right coin denomination is programmable from 1 to 9999.

n. PROGRAM LOCATION 11 (PL11)

Time Per Left Coin

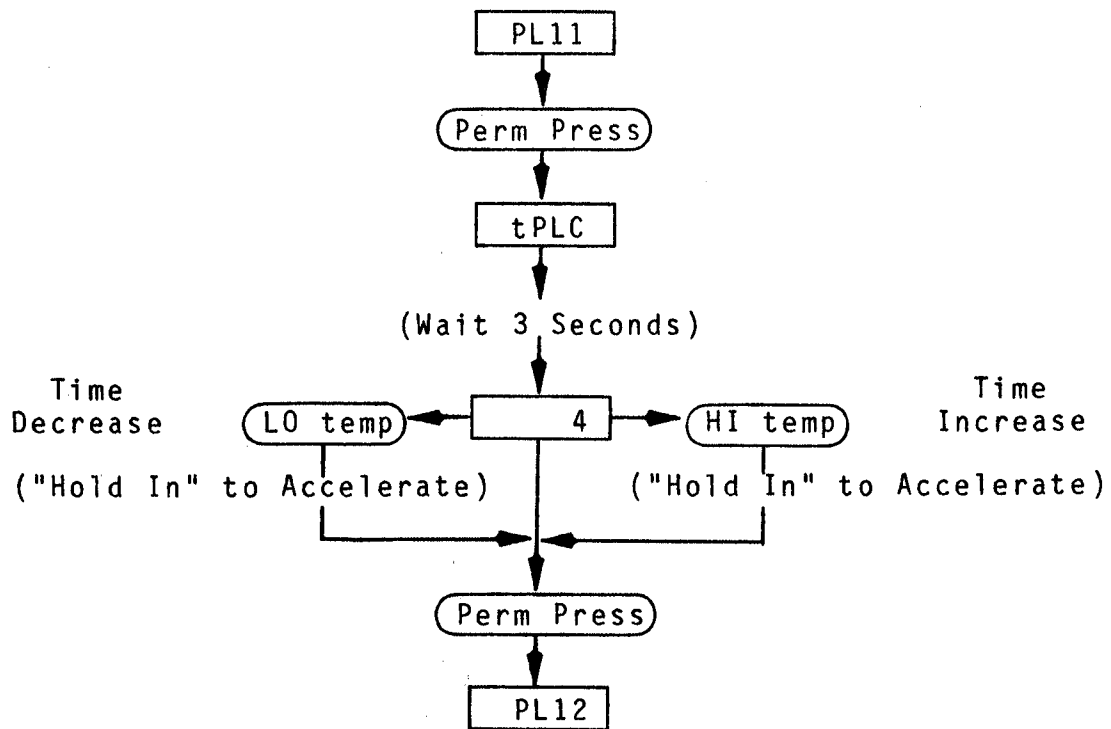

Summary: The time per left coin is programmable from 1 to 99 minutes.



o. PROGRAM LOCATION 12 (PL12)

Amount to Start

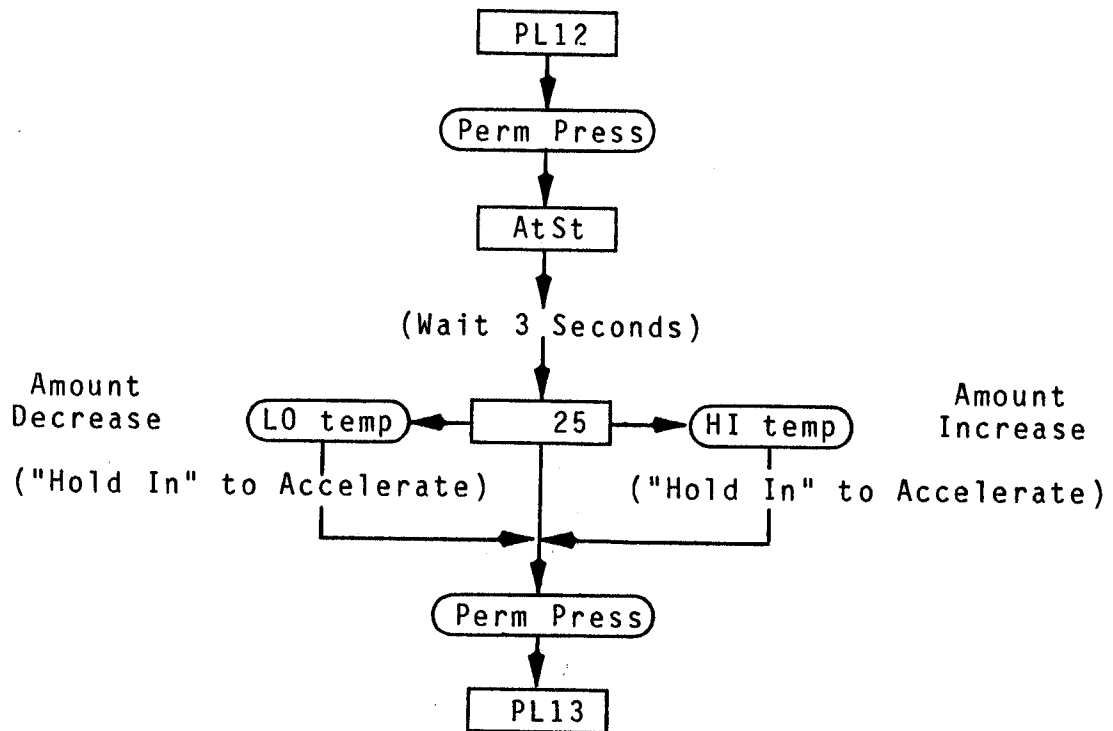

Summary: The amount to start is programmable from 1 to 9999.

p. PROGRAM LOCATION 13 (PL13)

Coin Accumulation Minimum Amount for More Time

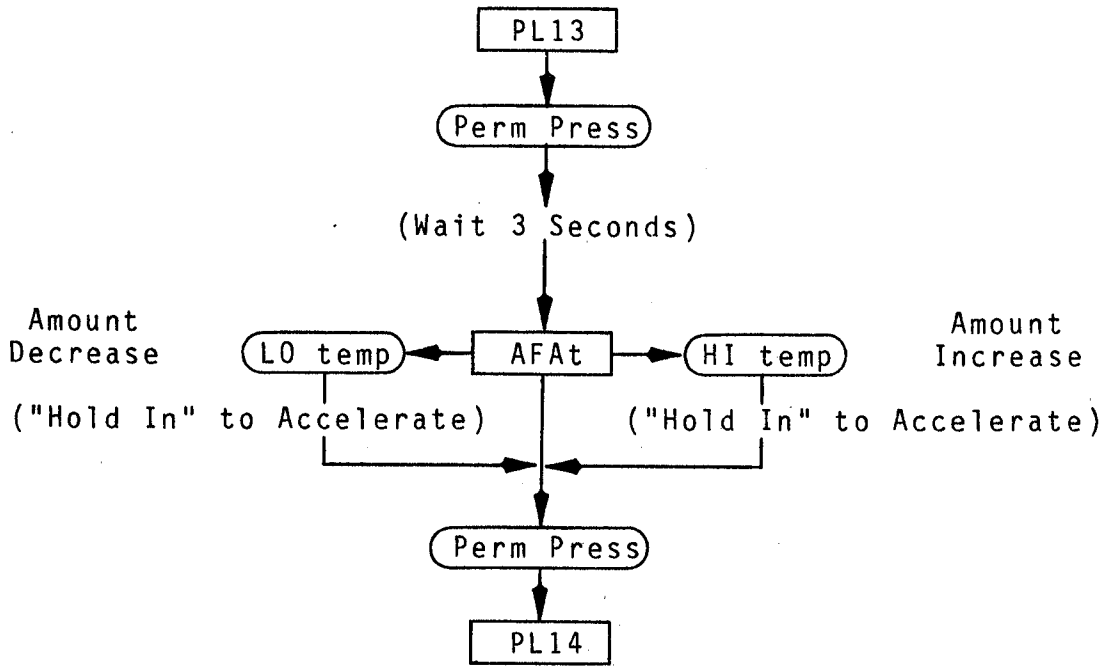

Summary: The amount for additional time is programmable from 1 to 9999.

q. PROGRAM LOCATION 14 (PL14)

Maximum Time for Auto Dry

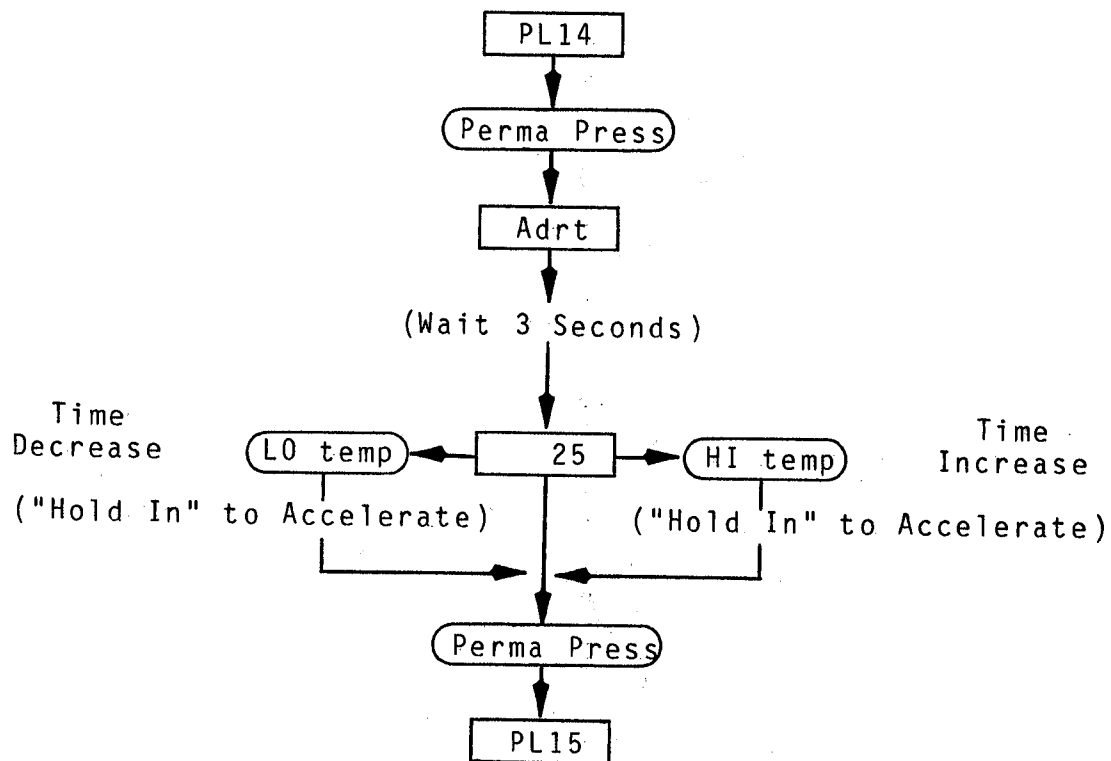

Summary: The maximum auto dryness time is programmable from 1 to 99 minutes.

r. PROGRAM LOCATION 15 (PL15)

Anti-Wrinkle Timing

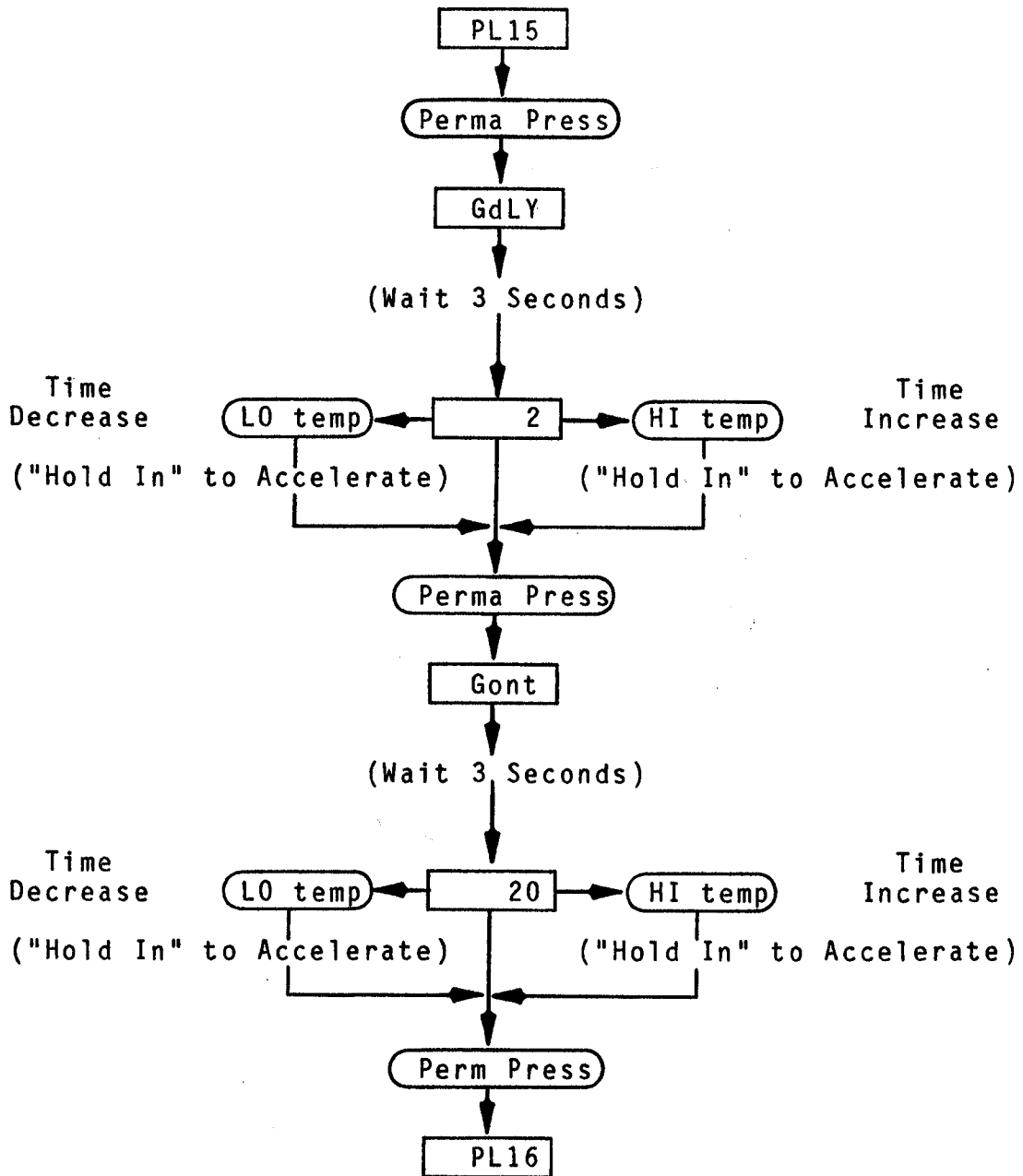

Summary: Guard delay time is programmable from 1 to 9 minutes. Guard on time is programmable from 1 to 99 seconds.

s. PROGRAM LOCATION 16 (PL16)

Maximum Active Anti-Wrinkle Time

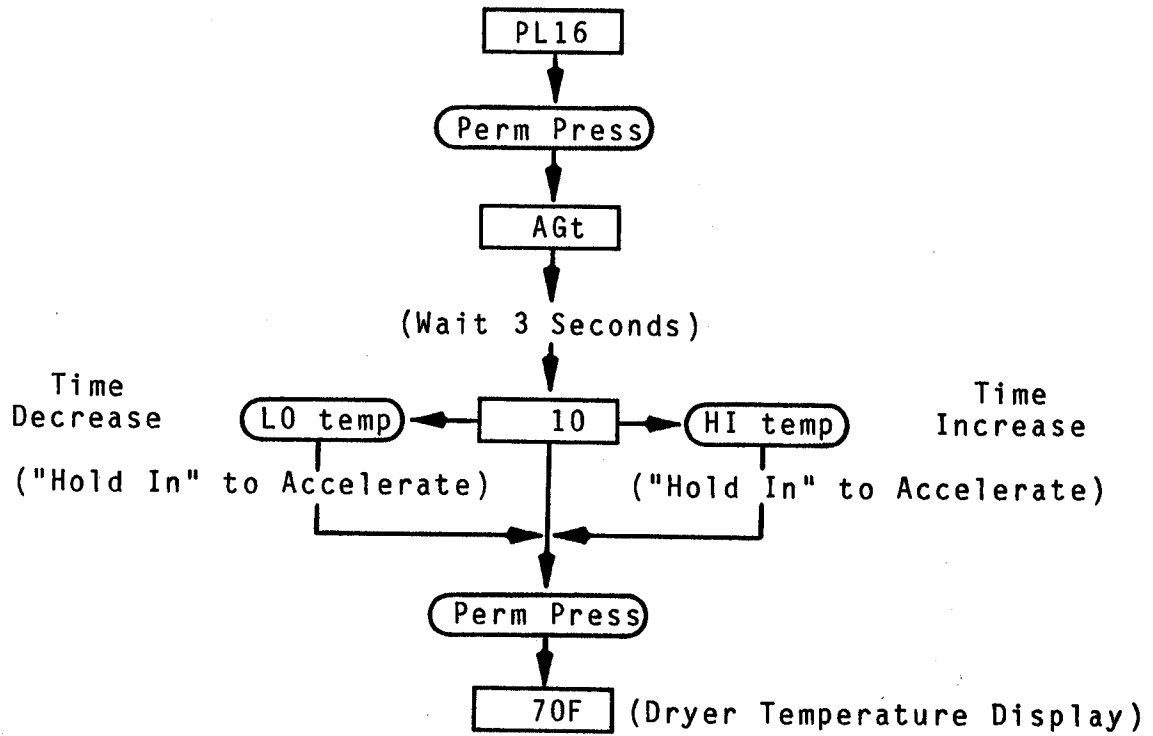

Summary: The maximum active guard time is programmable from 1 to 99 minutes.

## 7. Factory Pre-set Programs

Unless otherwise specified at the time of ordering, the Phase 3 computer has been pre-programmed by the factory with the following parameters. Should changes be found necessary, please read this manual carefully to thoroughly familiarize yourself with the Phase 3 programming characteristics.

### a. DUAL COIN

PL01	°FAr tInE Grd buZ Coin FLS bCrS Atin	-Temperatures in Fahrenheit -Timed mode -Anti-wrinkle guard on -Anti-wrinkle guard buzzer (tone) on -Coin(s) required to start -Display will flash in intervals between "FILL" and "Amount to Start" -Bad coin reset -Accumulative time
PL02	drYL	-Dryness level set at 25
PL03	HI°F	-180°
PL04	HICd	-Temperature - 100° Time - 2 minutes
PL05	LO°F	-120°
PL06	LOCd	-Temperature - 100° Time - 2 minutes
PL07	PP°F	-150°
PL08	PPCd	-Temperature - 100° Time - 3 minutes
PL09	LCdE	-Left coin denomination - 10
PL10	rCdE	-Right coin denomination - 25
PL11	tPLC	-Time per left coin - 4 minutes
PL12	AtSt	-Amount to start - 25
PL13	AFAt	-Amount for additional time - 10
PL14	Adrt	-Automatic dry maximum time - 30 minutes
PL15	GdLY Gont	-Anti-wrinkle guard off delay - 2 minutes -Anti-wrinkle guard on time - 20 seconds
PL16	AGT	-Active Anti-wrinkle guard time - 10 minutes

b. SINGLE COIN ONLY

PL01	°FAr	-Temperatures in Fahrenheit
	tInE	-Timed mode
	Grd	-Anti-wrinkle guard on
	buZ	-Anti-wrinkle guard buzzer (tone) on
	Coin	-Coin(s) required to start
	FLS	-Display will flash in intervals between "FILL" and "Amount to Start"
	bCrS	-Bad coin reset
	Atin	-Accumulative time
PL02	drYL	-Dryness level set at 25
PL03	HI°F	-180°
PL04	HICd	-Temperature - 100°
	Time	- 2 minutes
PL05	LO°F	-120°
PL06	LOCd	-Temperature - 100°
	Time	- 2 minutes
PL07	PP°F	-150°
PL08	PPCd	-Temperature - 100°
	Time	- 3 minutes
PL09	LCdE	-Left coin denomination - 25
PL10	rCdE	-Right coin denomination - 25
PL11	tPLC	-Time per left coin - 10 minutes
PL12	AtSt	-Amount to start - 25
PL13	AFAt	-Amount for additional time - 10
PL14	Adrt	-Automatic dry maximum time - 30 minutes
PL15	GdLY	-Anti-wrinkle guard off delay - 2 minutes
	Gont	-Anti-wrinkle guard on time - 20 seconds
PL16	AGT	-Active anti-wrinkle guard time - 10 minutes

## 8. Optional 9 Volt Battery Back-up

Dryers ordered from the factory with the 9 volt battery back-up option (battery not included) allows the computer to maintain its operating status should a momentary power interruption occur while the dryer cycle is in progress.

It is suggested that the battery be replaced at least once a year or as found necessary. The battery life will depend on the age of the battery, the amount of power interruptions, and back-up time used.

### IMPORTANT

For proper operation use alkaline batteries only. Suggest Eveready Energizer, Duracell, or equivalent. DO NOT USE CARBON TYPE BATTERIES.



## SECTION IV

### Heat/Ignition Circuit Operation

#### A. Standard Glo-bar System (non-computer models)

On call for heat from the thermostat, ignitor (glo-bar) is energized and split coil valve opens as the following three circuits are made simultaneously:

1. From L1 side of line through holding coil, back to ground.
2. From L1 side of line, flame switch contacts (I.R. sensor), booster coil, back to ground.
3. From L1 side of line, flame switch contacts (I.R. sensor), ignitor (glo-bar), back to ground.

Approximately 15 seconds later, the ignitor attains ignition temperature and flame switch contacts open. The secondary valve will now open as the circuit is completed from L1 side at line through the secondary coil and the ignitor, back to ground. When this circuit is completed, the igniter starts to cool as the current draw is reduced from about 4 amps to less than one amp. As the flame switch contacts open, the current flow through the booster coil approaches zero ( $\emptyset$ ).

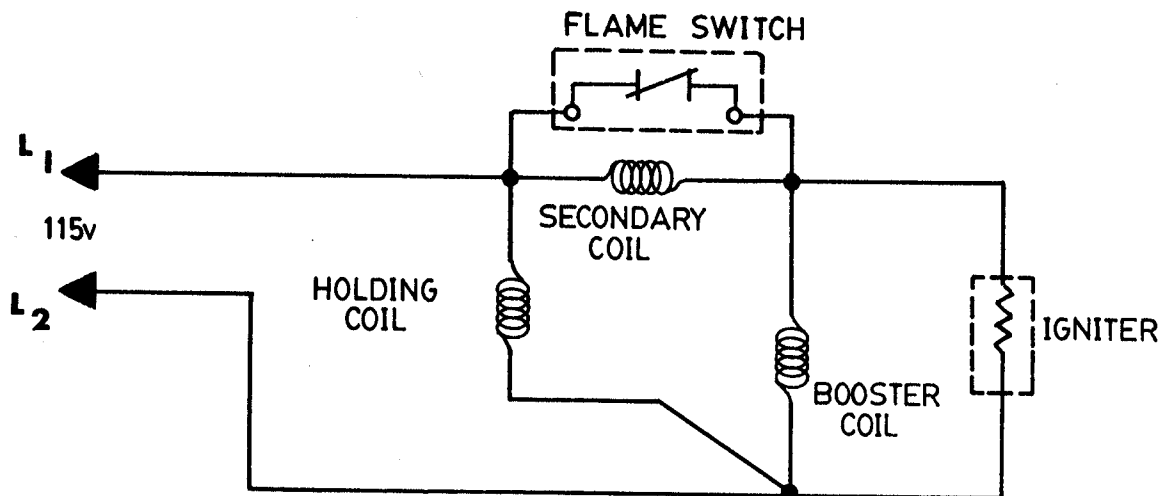
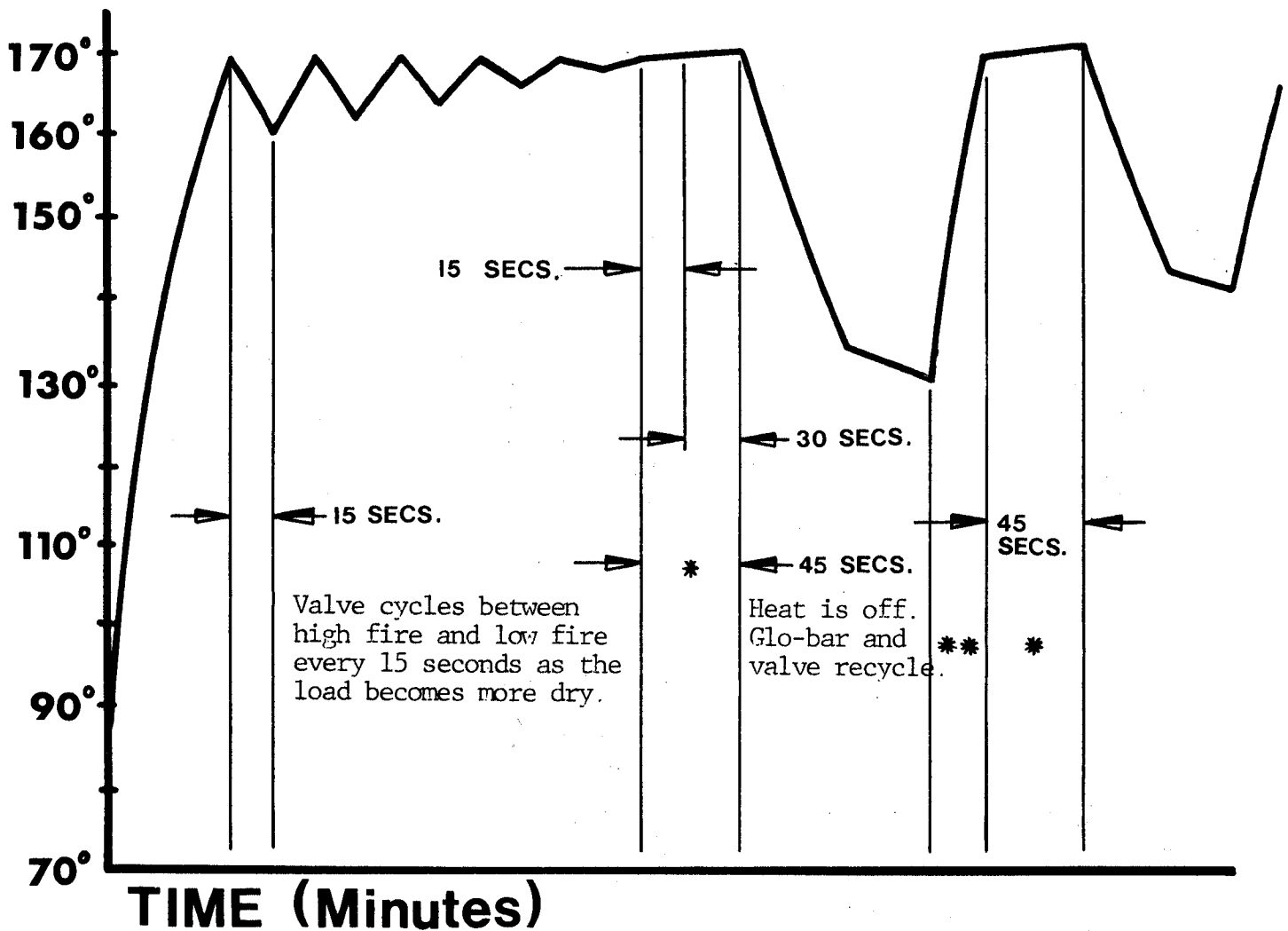

Fig. 1 Diagram For Std. (Non HI/LO) Ignition.

# Phase 3 HI LO Gas Valve Operation

## TEMPERATURE (°F)



NOTE: THIS DIAGRAM DEPICTS A COMPRESSED DRYING TIME AND AN ARBITRARY CYCLING TEMPERATURE.

\* AFTER 15 SECONDS, VALVE GOES INTO LOW FIRE, BUT THE TEMPERATURE REMAINS AT OR ABOVE THE PRESET TEMPERATURE IN LOW FIRE. THE TIMING CIRCUIT ON THE COMPUTER BOARD TAKES OVER, ALLOWING THE LOW FIRE TO REMAIN ON FOR ANOTHER 30 SECONDS. IF THE TEMPERATURE IS STILL AT OR ABOVE THE PRESET TEMPERATURE, THE VALVE TURNS THE GAS OFF COMPLETELY.

\*\* GLO-BAR IGNITES BURNER. VALVE IS IN HIGH FIRE.

## B. Computer-Controlled Hi/lo Gas Valve System

### 1. Introduction

The computer-controlled hi/lo gas valve system developed by American Dryer Corporation is a new advancement in clothes drying. The system consists of a hi/lo gas valve, Phase 3 computer, glo-bar (ignitor), and I.R. sensor (flame switch). With computer control of the gas valve, three (3) stages of gas flow are available: gas on high fire, gas on low fire, and gas off. During dryer operation, when the tumbler (basket/drum) cavity reaches the selected drying temperature, the computer cycles the gas valve between its high-fire and low-fire stages to maintain a constant drying temperature. The result of this constant drying temperature is a significant decrease in drying time and increase in dryer efficiency.

### 2. System Components

The 3/8" hi/lo gas valve contains the same two (2) redundant on/off solenoid valves as the standard 3/8" glo-bar ignition gas valve; and these two solenoids operate in the same manner and sequence in both valves. The difference in the hi/lo valve is the addition of a hi/lo solenoid located on the valve's side. This hi/lo solenoid is controlled by the computer, and this is the solenoid that can vary the gas flow from high-fire (full gas flow) to low-fire (approximately 50 percent of high-fire). This solenoid cannot shut off the gas flow entirely. The two on/off redundant solenoids do this.

The 3/8" hi/lo gas valve has eight (8) wires extending out of it. Four (4) are located at the manifold side of the gas valve - the two (2) black wires connect to the I.R. sensor (flame switch), and the two (2) red wires (marked IG) connected to the ignitor (glo-bar). The other four (4) extend out of the face side of the valve. The black and white wires supply main line voltage (always 115 volts) to the two redundant on/off solenoids, the glo-bar, and I.R. sensor. The red and blue wires supply voltage (always 115 volts) to the hi/lo solenoid. When the system is in high-fire, there is voltage (115 Volts) across the black and white wires, and across the red and blue wires. When in low fire, there is zero (0) volts across the red and blue wires; however, voltage (115 volts) will still be evident across the black and white wires.

### 3. Operation Sequence

When the dryer is started and both the heat circuit and gas valve circuit indicators of the computer display are on, the first on/off solenoid in the gas valve opens, the valve is put into its high-fire stage, and current is supplied to the glo-bar. When the glo-bar reddens and reaches sufficient temperature, the I.R. sensor contacts open which, in turn, opens the second on/off

solenoid in the gas valve. This allows gas to flow into the burners and be ignited. When the tumbler cavity reaches the selected drying temperature, the computer display heat circuit indicator goes off, and the gas flow is reduced to low fire. The computer monitors the temperature in the dryer every 15 seconds. At the end of this 15-second period (while the valve is in low fire), if the tumbler temperature has dropped below the selected drying temperature, the computer will return the gas valve to its high-fire stage (computer display heat circuit indicator comes back on). High-fire remains on until the selected drying temperature is again reached, at which point, the low-fire stage is again activated. This high-fire/low-fire cycle will continue as long as the tumbler's temperature is below the selected drying temperature at the end of the 15-second monitoring period of the computer. As the clothes in the tumbler get dryer, low-fire gas flow will eventually produce enough heat to keep the tumbler at or above the selected drying temperature. When, at the end of the 15-second low-fire period, if the tumbler's temperature is equal to or above the selected drying temperature, the computer will keep the gas valve in its low-fire stage for approximately 30 more seconds. At the end of this 30-second period of low fire, the computer again checks the tumblers temperature. If the tumbler's temperature has dropped below the selected drying temperature, then the high-fire stage is turned back on. If, however, the tumbler's temperature is still above the selected drying temperature, then the gas flow is shut off (Both heat circuit and gas valve circuit display indicators will be off). At this point, the glo-bar ignition sequence is restarted.

The dryer will continue to operate until either the drying time runs out or, in the case of the automatic/free dry modes, a preset number of drying cycles (dryness level) has been reached.

## SECTION V

### Maintenance

#### A. Cleaning

A program or schedule should be established for periodic inspection, cleaning, and removal of lint from various areas of the dryer, as well as throughout the duct work system. The frequency of cleaning can best be determined from experience at each location. Maximum operating efficiency is dependent upon proper air circulation. The accumulation of lint can restrict this air flow. If the guide lines in this section are met, an American dryer will provide many years of efficient, trouble-free, and....most importantly....safe operation.

WARNING: Lint from most fabrics is highly combustible. The accumulation of lint can create a potential fire hazard.

#### Suggested Interval

#### Function

Daily Clean lint from the lint trap, screen, bottom, and walls of the lint chamber. Inspect lint screen and replace if torn.

90 Days Remove lint accumulation from lint chamber thermostats and sensors.

WARNING: To avoid the hazard of electrical shock, discontinue electrical supply to the dryer.

90 Days Remove lint from the motor air vents and surrounding area.

IMPORTANT: Lint accumulation will restrict internal motor air flow, causing overheating and irreparable motor damage. Motor failure due to lint accumulation will void the manufacturers warranty.

120 Days Remove lint from gas burner area with a dusting brush or vacuum cleaner attachment.

NOTE: To prevent damage, avoid cleaning or touching ignitor (glo-bar).

6 Months Inspect and remove lint accumulation in customer-furnished exhaust duct work system.

IMPORTANT: The accumulation of lint in the exhaust

duct work can create a potential fire hazard.

6 Months      Inspect and remove lint accumulation from the dryer exhaust back draft damper.

NOTE: A back draft damper that is sticking partially closed can result in slow drying and shutdown of the heat circuit safety switches or thermostats.

As Required    In the cleaning and care of the cabinet, avoid using harsh abrasives. A product intended for the cleaning of appliances is recommended.

### B. Adjustments

#### Suggested Interval

#### Function

7 Days After Installation and Every 6 Months      Inspect bolts, nuts, screws, non-permanent gas connections (unions, orifices, etc.), electrical terminals, and grounding connections.

6 Months      Motor and drive belts should be examined. Cracked or seriously frayed belts should be replaced. Tighten loose belts when necessary and check belt alignment.

6 Months      Complete operational check of controls and valves.

6 Months      Complete operational check of all safety devices (door switches, sail switch, burner and lint chamber thermostats).

### C. Lubrication

The motor bearings, idler bearings, and tumbler bearings are permanently lubricated and no relubrication is necessary. Some tumbler bearings are equipped with grease fittings. Should lubrication ever be found necessary, use a general purpose lithium-based grease. (Do not use animal- or vegetable-based lubricants.) Do not overgrease. Be sure grease fitting is thoroughly cleaned of all foreign material before greasing.

## SECTION VI

### Parts Manual Illustrations and Descriptions

When ordering replacement parts from your distributor or the factory, specify the dryer model number and serial number in addition to the part description and part number, so that your order is processed accurately and promptly.

When ordering replacement parts from the factory, credit card orders are accepted. Please refer to page 155 for detailed information.

The illustrations on the following pages may not depict your particular dryer exactly. The illustrations are a composite of the various dryer models. Be sure to check the description of the parts thoroughly before ordering.

### TABLE OF CONTENTS

Control Door Assembly (Standard).....	70
Control Door Assembly (High Security).....	71
Control Panel Assembly (Non-computer).....	72, 73
Coin Meter Replacement Parts (Non-computer).....	74
Control/Heat Step Down Transformer.....	75
Control Panel Assembly (Single Coin Computer).....	76, 77
Control Panel Assembly (Dual Coin Computer).....	78, 79
Front Panel Assembly.....	80
Main Door Assembly.....	81
Lint Door Assembly.....	82
Coin Vault Assembly.....	83
Tumbler/Support Assembly.....	84, 85
Lint Trap Assembly.....	86
Tumbler Bearing Assembly.....	87
Idler Bearing Assembly.....	88, 89
Standard Motor Mount Assembly.....	90, 91
Totally Enclosed Motor Mount Assembly.....	92, 93
Thermostat/Sensor Assembly.....	94, 95
Burner Assembly (Non-computer).....	96, 97
Burner Assembly (Hi/lo Computer).....	98, 99
Sail Switch/Hi-limit Assembly.....	100
Gas Valve Replacement Coils (Non-computer).....	101
Gas Valve Replacement Coils (Hi/lo Computer).....	102
3-Phase Electric Relay Panel Assembly.....	103
Outer Top/Back Guard Assembly.....	104
Additional Parts List.....	105

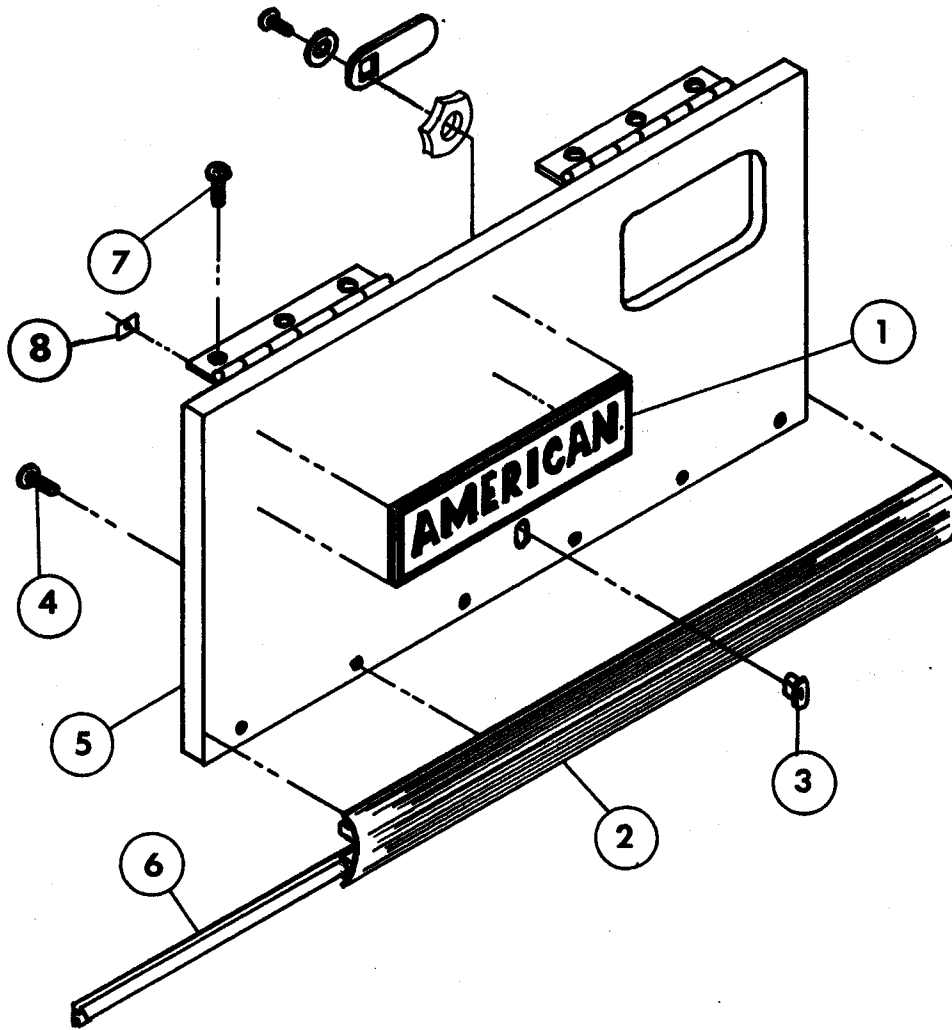

STANDARD CONTROL DOOR ASSEMBLY

<u>Illus. No.</u>	<u>Part No.</u>	<u>Qty.</u>	<u>Description</u>
1	112302	1	American Computer Logo
	112314	1	American Fluff Dry Logo
2	300204	1	Trim Strip (28")
3	160002	1	MK-100 Lock Assembly with Key
	160104	1	MK-100 Key Only
	160008	1	Lock Cam
4	150201	5	10/32 x 1/4 Phil. R.H. Machine Screw
5	800014*	1	285 Control Door Assembly Complete (less lock and logo)
6	102307	3	Bumper Gasket (sold in feet)
7	150300	4	#10 x 1/2 S.D. Screw
8	154002	2	1/8" Push-on Fastener

\* Specify color when ordering.



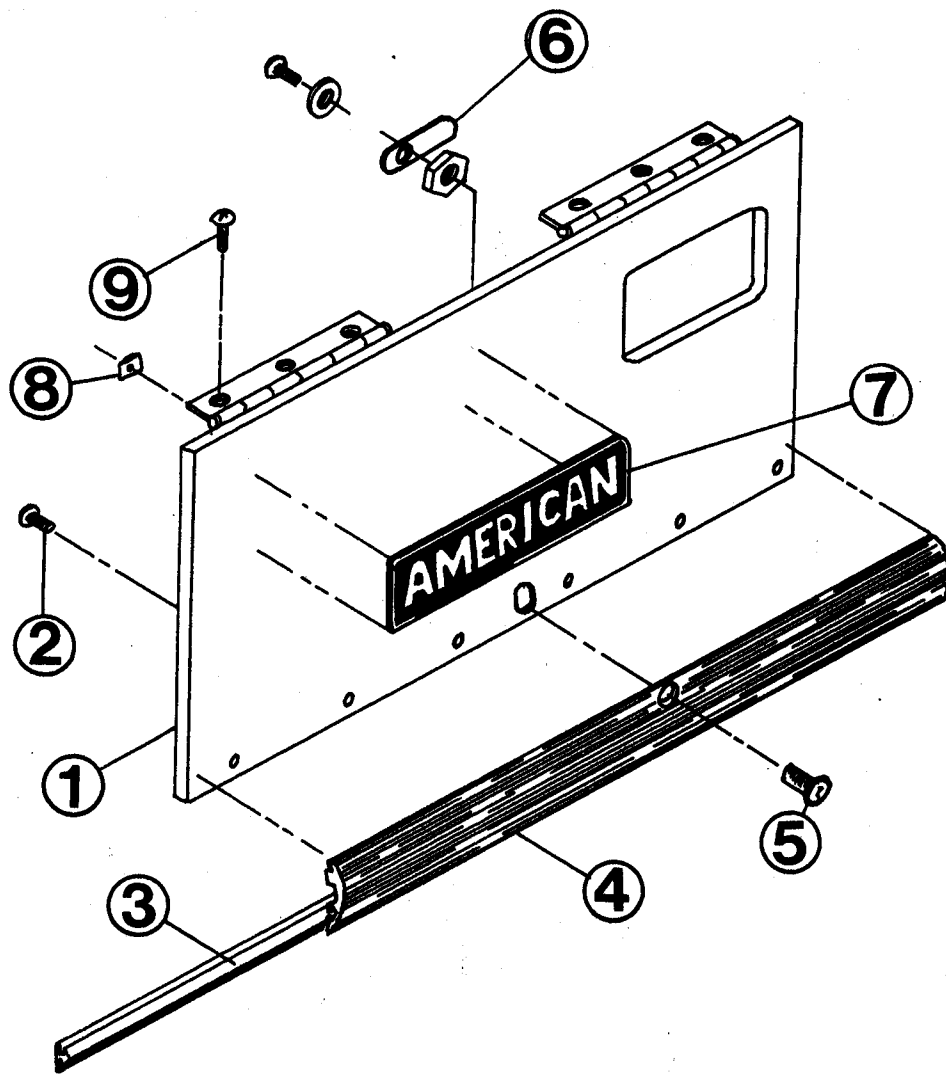

285 HIGH SECURITY CONTROL DOOR ASSEMBLY

<u>Illus. No.</u>	<u>Part No.</u>	<u>Qty.</u>	<u>Description</u>
1	800019*	1	285 High Security Control Door Assembly Complete (less lock and logo)
2	150201	5	10/32 x 1/4 Phil. R.H. Machine Screw
3	102307	3	Bumper Gasket (sold in feet)
4	300210	1	Trip Strip (28") with Lock Hole
5	160015	1	High Security MK-100 Lock Assembly with Key
	160104	1	MK-100 Key Only
6	160016	1	Lock Cam
7	112302	1	American Computer Logo
	112314	1	American Fluff Dry Logo
8	154002	2	1/8" Push-on Fastener
9	150300	4	#10 x 1/2 S.D. Screw

\* Specify color when ordering.

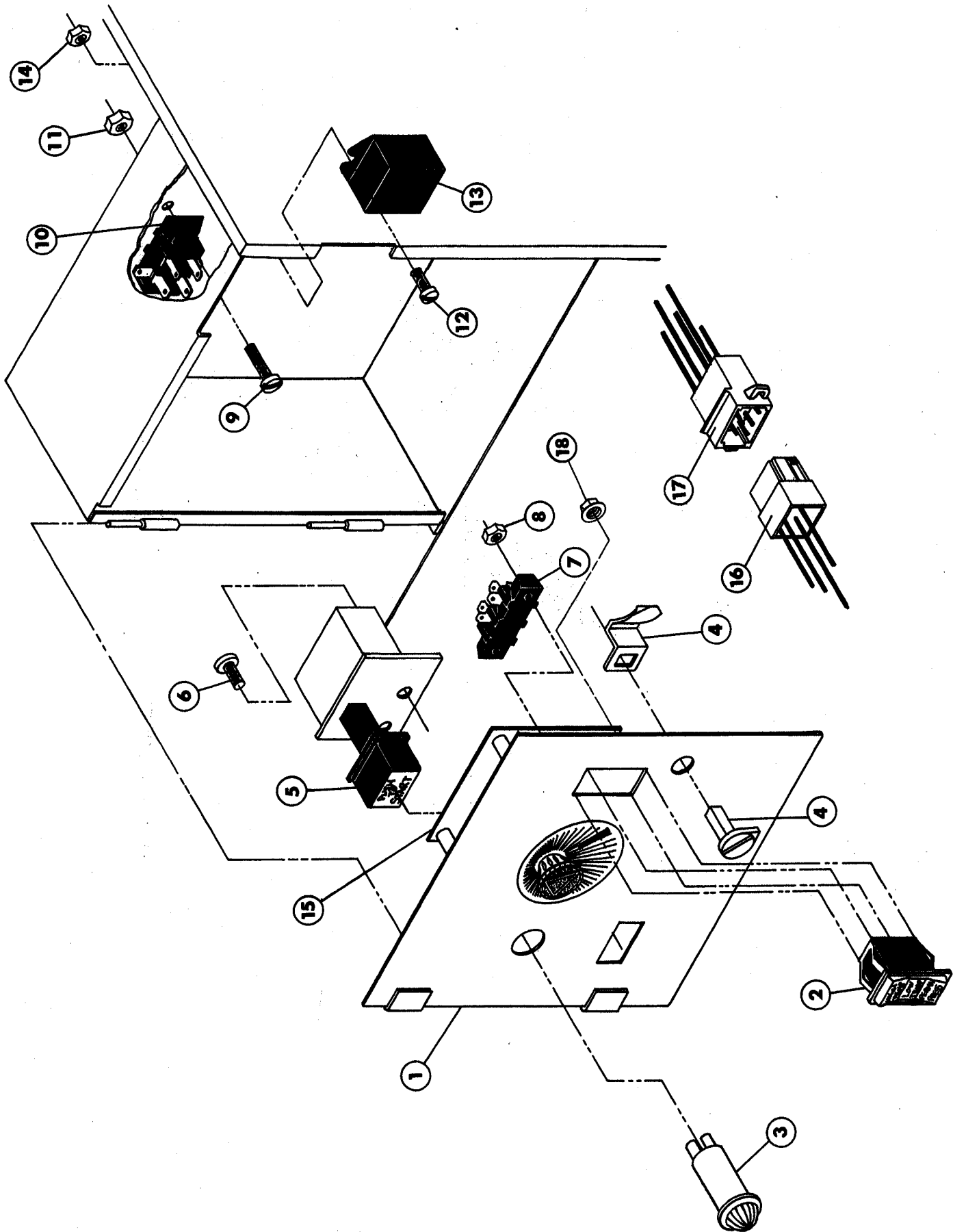

CONTROL PANEL ASSEMBLY (NON-COMPUTER)

<u>Illus. No.</u>	<u>Part No.</u>	<u>Qty.</u>	<u>Description</u>
1	800070	1	Coin Meter Control Panel Assembly 115V Complete (less meter)
	800071	1	Coin Meter Control Panel Assembly 230V Complete (less meter)
	800052	1	Coin Meter Control Panel Only
2	122400	1	Heat Selector Switch
3	123000	1	Indicator Light 115V
	123001	1	Indicator Light 220V
4	160005	1	Turn Latch Fastener (2-piece)
5	131812	1	Push to Start Relay 115V
	131813	1	Push to Start Relay 220V
	154001	2	Relay (10/24) Speed Mounting Nut
6	150207	2	10/32 x 1/2" R.H. Machine Screw
7	120707	1	Terminal Strip (2-position)
8	152013	2	6/32 Hex Nut
9	150002	2	6/32 x 1" R.H. Machine Screw
10	120709	1	Terminal Strip (8-position)
11	151000	1	6/32 Pal Nut
12	150001	2	6/32 x 1/2" R.H. Machine Screw
13	131814	1	115V Motor Relay
	131815	1	220V Motor Relay
14	151000	2	6/32 Pal Nut
15*	125000	1	25¢ 115V Meter (specify timing)
	125003	1	25¢ 220V Meter (specify timing)
16	122602	1	9-Pin Connector Only
	122700	9	Pin Terminal Only
17	122603	1	9-Pin Socket Connector Only
	122701	9	Socket Terminal Only
18	152014	2	1/4"-20 Free Spin Nut

\* Consult factory for coin meters not listed.

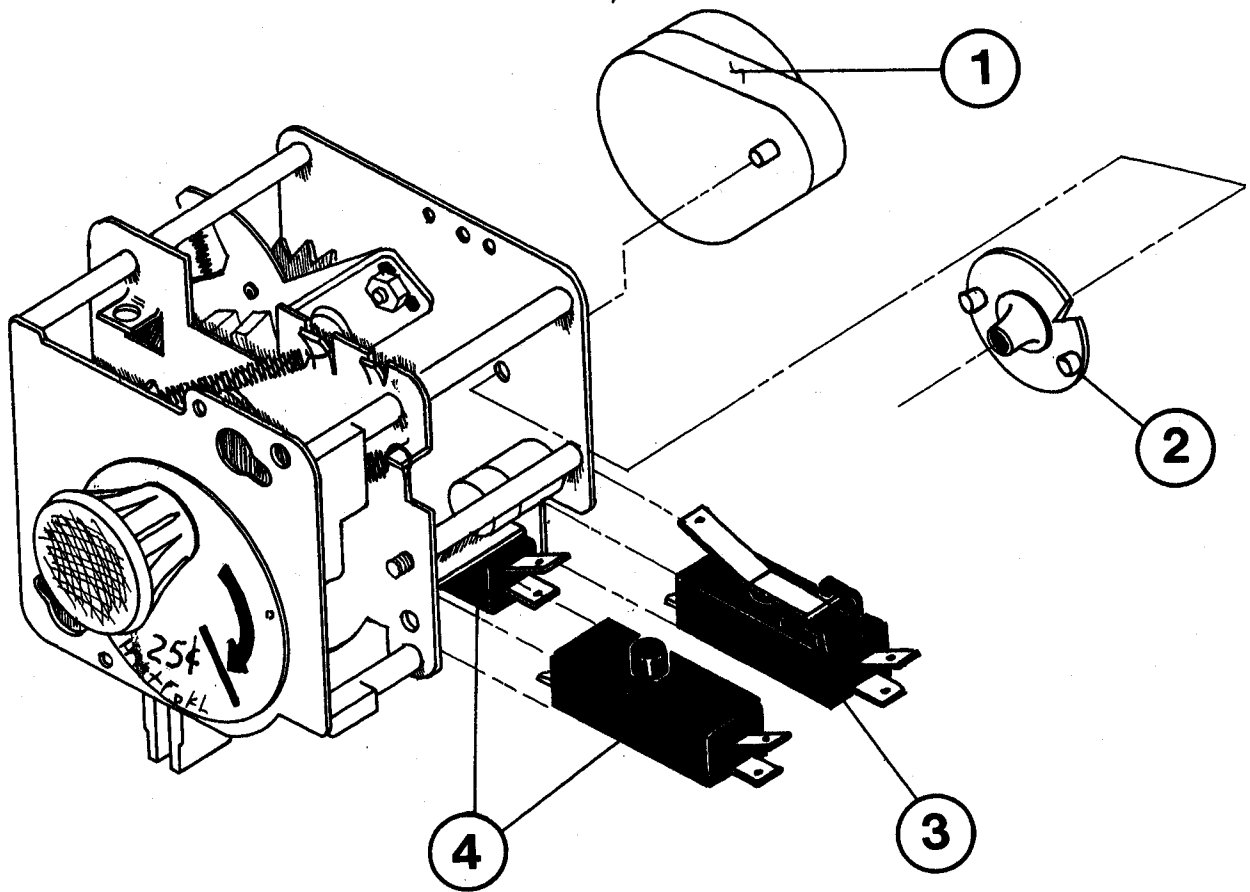

COIN METER REPLACEMENT PARTS

<u>Illus. No.</u>	<u>Part No.</u>	<u>Qty.</u>	<u>Description</u>
1	125511	1	1/60 RPM 115V 60HZ Meter Motor
	125532	1	1/60 RPM 230V 60HZ Meter Motor
	125512	1	1/60 RPM 240V 50HZ Meter Motor
	125513	1	1/30 RPM 240V 50HZ Meter Motor
2	125500	1	2-Pt. Cam
	125501	1	3-Pt. Cam
	125502	1	4-Pt. Cam
	125503	1	5-Pt. Cam
	125504	1	6-Pt. Cam
	125506	1	8-Pt. Cam
	125507	1	9-Pt. Cam
	125508	1	10-Pt. Cam
	125510	1	12-Pt. Cam
	3	125515	1
4	125516	2	Meter Switch "A" or "C"

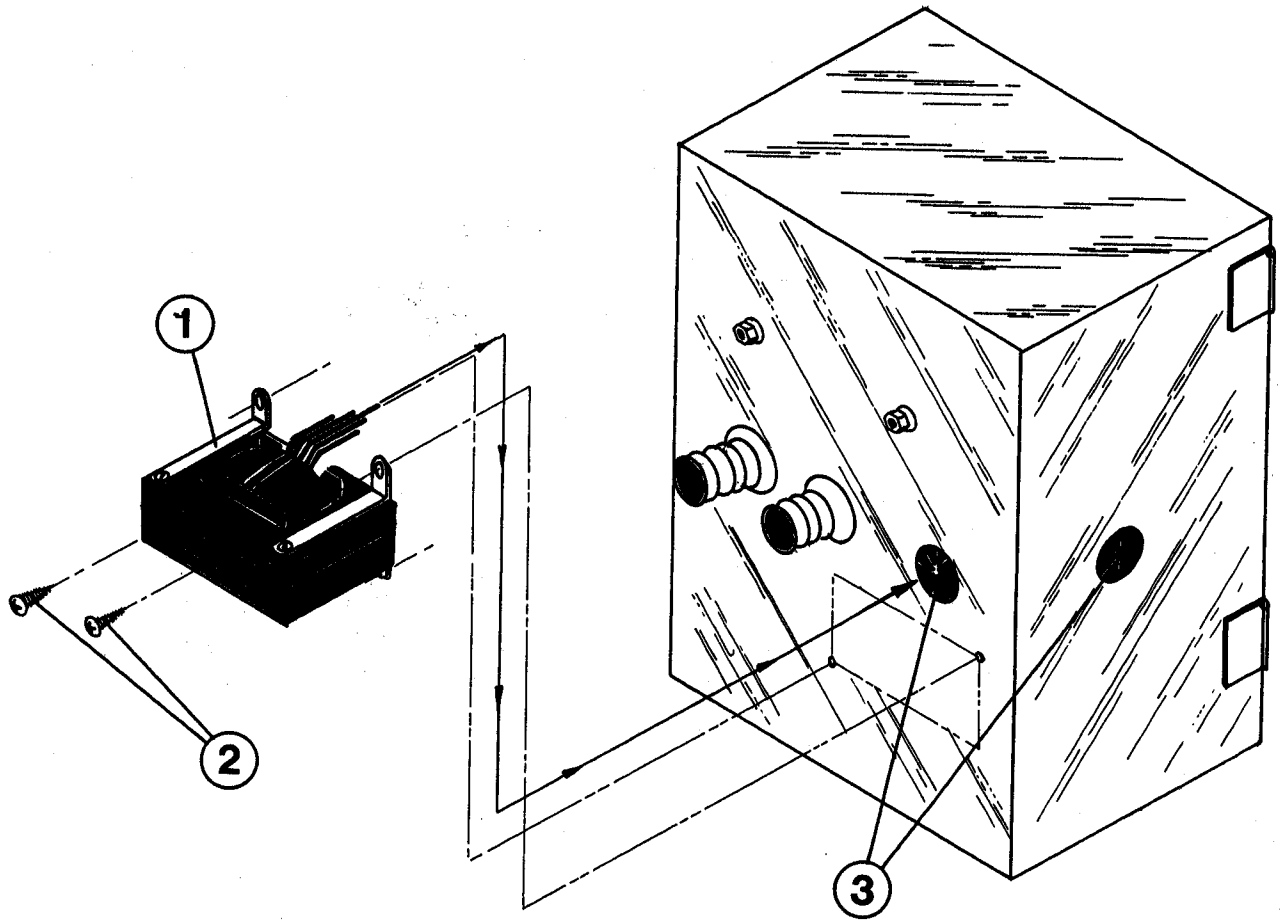

CONTROL/HEAT STEPDOWN TRANSFORMER

<u>Illus. No.</u>	<u>Part No.</u>	<u>Qty.</u>	<u>Description</u>
1	132002*	1	200 Watt Transformer
2	150300	2	#10 x 1/2" S.D. Screw
3	121400	-	Universal Bushing

\* 208/230 volt control models only

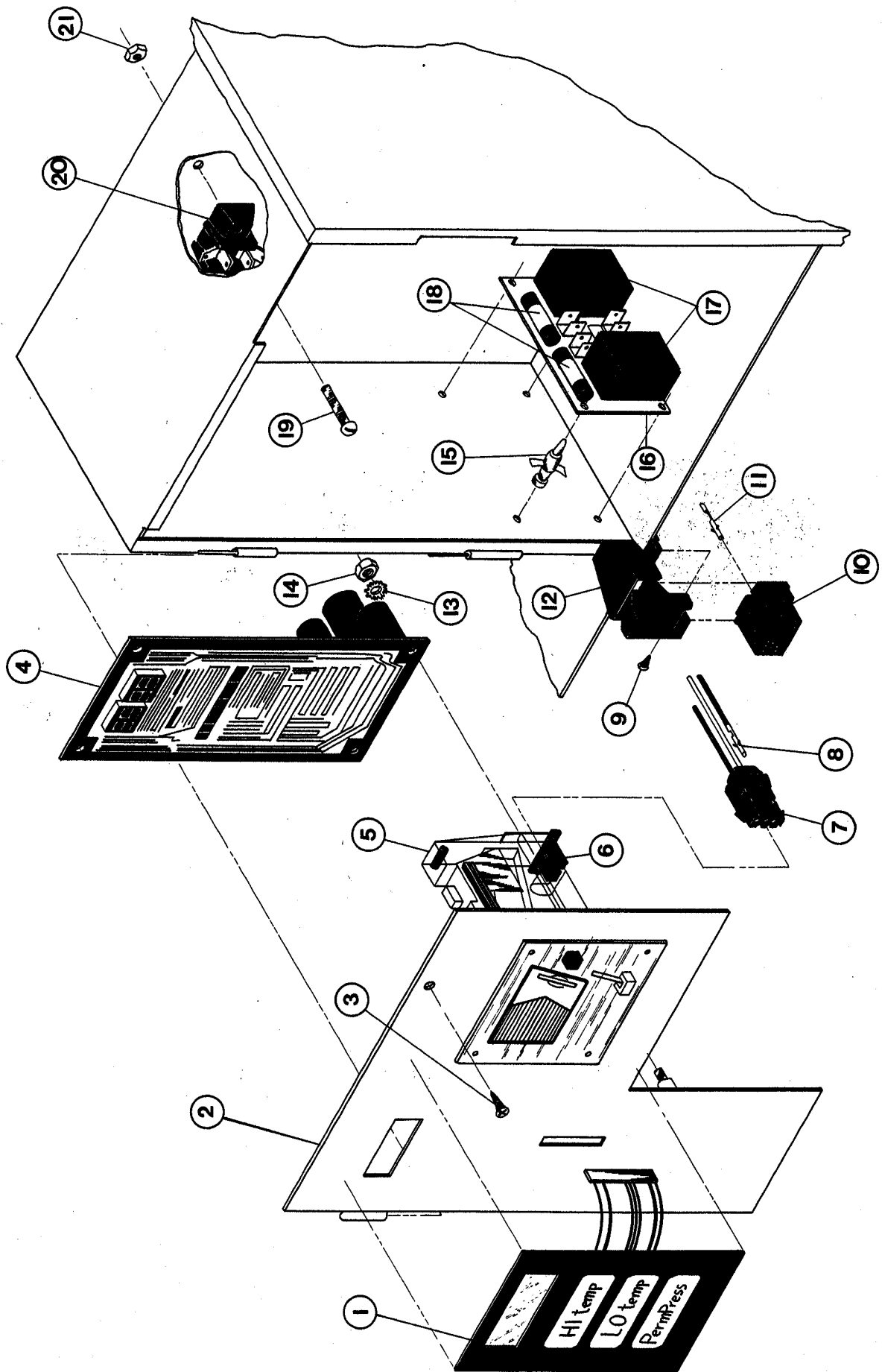

CONTROL PANEL ASSEMBLY (SINGLE COIN COMPUTER)

<u>Illus. No.</u>	<u>Part No.</u>	<u>Qty.</u>	<u>Description</u>
1	112526	1	Ph 3 Coin Keyboard Label
2	800087	1	Ph 3 Control Panel Assembly Complete (less acceptor)
	865500	1	Ph 3 Coin Control Panel Assembly Complete with Battery Option (less acceptor)
	800040	1	Coin Control Panel Only
	800039	1	Coin Control Panel Only with Battery Bracket
3	150200	1	10/32 x 1/2" Tappit Screw
4	137075	1	Ph 3 Coin Controller
	137086	1	Ph 3 Coin Controller with Battery Connector
5*	865460	1	25¢ Optic Coin Acceptor
	865461	1	10NP Optic Coin Acceptor
	865462	1	5 Belgium Franc Optic Coin Acceptor
	865463	1	.882 Token Optic Coin Acceptor
	865480	1	.800 Token Optic Coin Acceptor
	865464	1	100 Yen Optic Coin Acceptor
	865466	1	French Franc Optic Coin Acceptor
	865469	1	1 Danish Krona Optic Coin Acceptor
	865474	1	20NP Optic Coin Acceptor
	865475	1	1 Pound English Optic Coin Acceptor
6	137056	1	Optic Switch Only
	401020		Adhesive for Mounting Optic Switch
7	137023	1	Optic Switch Connector Only
8	137021	3	Sockets Only
	865050	1	Single Coin Optic Switch Harness
9	150301	1	#8 x 7/16" TEK Screw
10	137020	1	15-Pin Connector Only
11	137021	14	M.P. Sockets Only
12	137022	1	Strain Relief
13	153012	4	#8 Star Washer
14	152001	4	8/32 Hex Nut
15	137013	4	Stand Off
16	137077	1	A.S. Board with Relays 115V (less fuses)
	137061	1	A.S. Board Only
17	131916	2	P.C.B. Relay 115V
18	136052	2	4 Amp Fuse
19	150002	2	6/32 x 1" R.H. Machine Screw
20	120709	1	Terminal Strip (8-position)
21	151000	2	6/32 Pal Nuts
--	122800	-	Micro-processor Socket Extractor Tool

\* Consult factory for coin acceptors not listed.

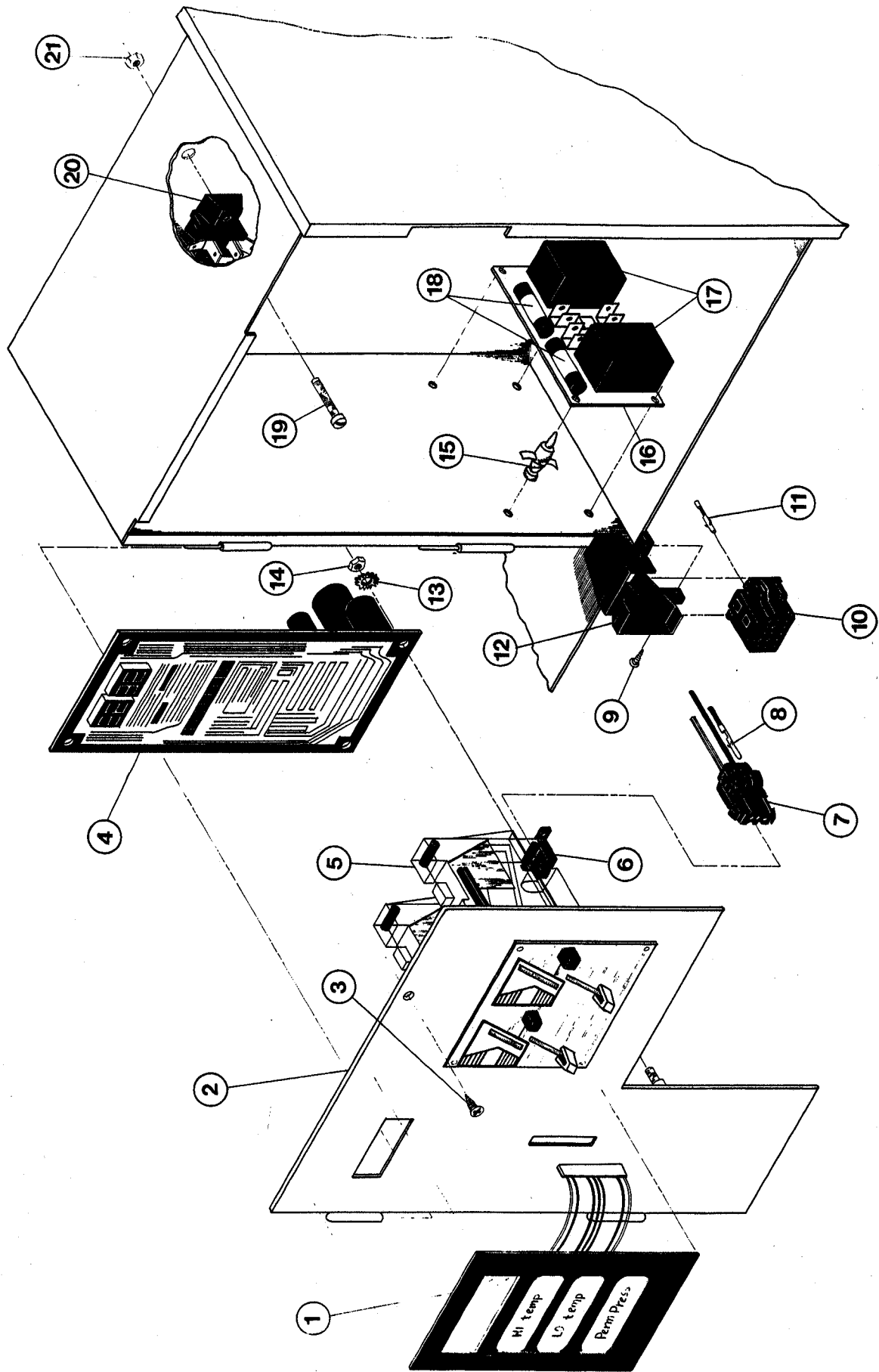



CONTROL PANEL ASSEMBLY (DUAL COIN COMPUTER)

<u>Illus. No.</u>	<u>Part No.</u>	<u>Qty.</u>	<u>Description</u>
1	112526	1	Ph 3 Coin Keyboard Label
2	800087	1	Ph 3 Coin Control Panel Assembly Complete (less acceptor)
	865500	1	Ph 3 Coin Control Panel Assembly Complete with Battery Option (less acceptor)
	800040	1	Coin Control Panel Only
	800039	1	Coin Control Panel Only with Battery Bracket
3	150200	1	10/32 x 1/2" Tappit Screw
4	137075	1	Ph 3 Coin Controller
	137086	1	Ph 3 Coin Controller with Battery Connector
5*	865476	1	10/25¢ Optic Coin Acceptor
	865465	1	50/100 Yen Optic Coin Acceptor
	865470	1	10/50P Optic Coin Acceptor
	865471	1	20/50P Optic Coin Acceptor
	865472	1	10/20P Optic Coin Acceptor
	865473	1	1 Pound/20P Optic Coin Acceptor
	865477	1	1 Krone/5 Krona Optic Coin Acceptor
	865478	1	20/50 Singapore Optic Coin Acceptor
	865479	1	20/5 Belgium Franc Optic Coin Acceptor
6	137056	2	Optic Switch Only
	401020	-	Adhesive for Mounting Optic Switch
7	137023	2	Optic Switch Connector Only
8	137021	6	Sockets Only
	865051	1	Dual Coin Optic Switch Harness
9	150301	1	#8 x 7/16" TEK Screw
10	137020	1	15-Pin Connector Only
11	137021	15	Micro-processor Sockets Only
12	137022	1	Strain Relief
13	153012	4	#8 Star Washer
14	152001	4	8/32 Hex Nut
15	137013	4	Stand-off
16	137077	1	A.S. Board with Relays 115V (less fuses)
	137061	1	A.S. Board Only
17	131916	2	P.C.B. Relay 115V
18	136052	2	4 Amp Fuse
19	150002	2	6/32 x 1" R.H. Machine Screw
20	120709	1	Terminal Strip (8-position)
21	151000	2	6/32 Pal Nut
--	122800	-	Micro-processor Pin Extractor Tool

\* Consult factory for coin acceptors not listed.

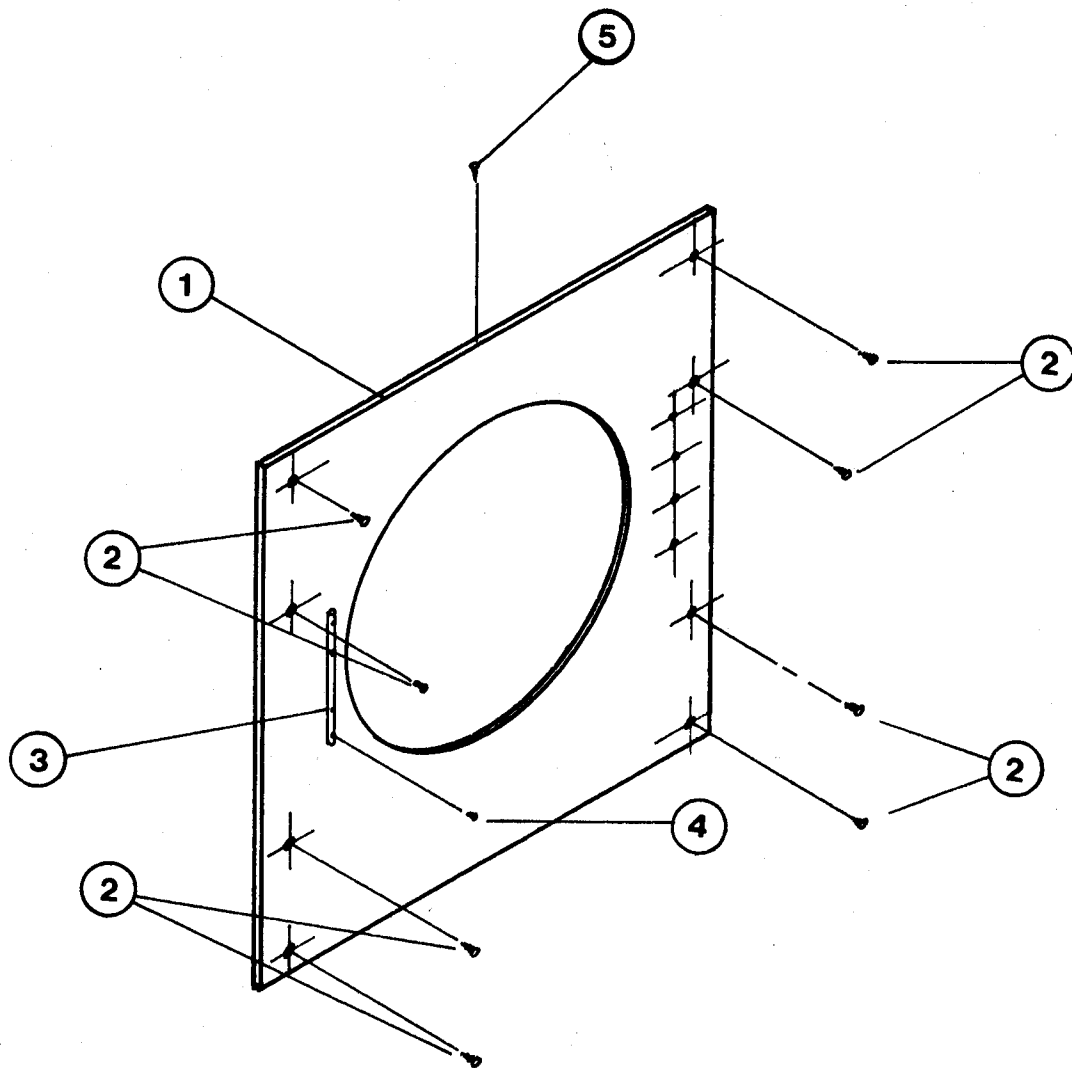

FRONT PANEL ASSEMBLY

<u>Illus. No.</u>	<u>Part No.</u>	<u>Qty.</u>	<u>Description</u>
1	800365*	1	285 Front Panel with Insulation
2	150200	8	10/32 x 1/2" Tappit Screw
3	313902	1	Striker Pad
4	154200	3	Pop Rivets (5/32)
5	150300	1	#10 x 1/2" S.D. Screw

\* Specify color when ordering.

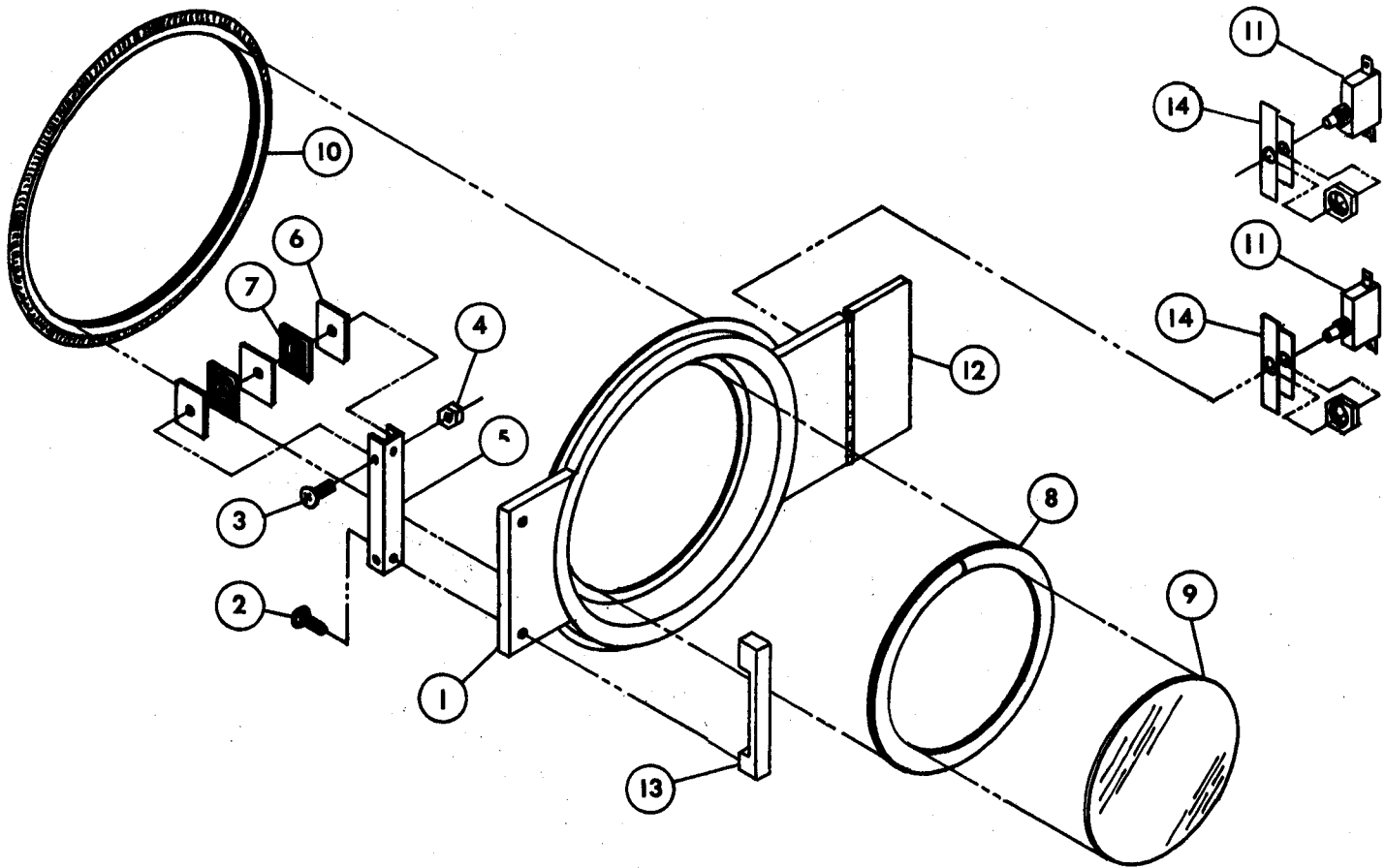

MAIN DOOR ASSEMBLY

<u>Illus. No.</u>	<u>Part No.</u>	<u>Qty.</u>	<u>Description</u>
1	870001	1	285 Micro-processor Main Door Assembly Complete
	800120	1	285 Non-computer Main Door Assembly Complete
	800121	1	285 Main Door Assembly with Right Hinge Pad (less accessories)
2	150111	2	1/4-20 x 1/2" R.H. Machine Screw
3	150002	2	6/32 x 1" R.H. Machine Screw
4	152000	2	6/32 Hex Nut
5	306803	1	Magnet Holder
6	306802	6	Magnet Keeper
7	102102	4	Magnets
	800130	1	Magnet Channel Assembly Complete (includes illus. nos. 3, 4, 5, 6, and 7)
8	102305	1	Glass Gasket (63")
9	102203	1	Glass (19-1/2")
10	102306	1	Door Gasket (67")
11	122001	1 or 2	Door Switch
	152003	1 or 2	Door Switch Nuts
12	800348	1	285 Right Hinge Pad Only
13	170202	1	Main Door Handle (10-1/4")
14	313207	1 or 2	Main Door Switch Mounting Bracket

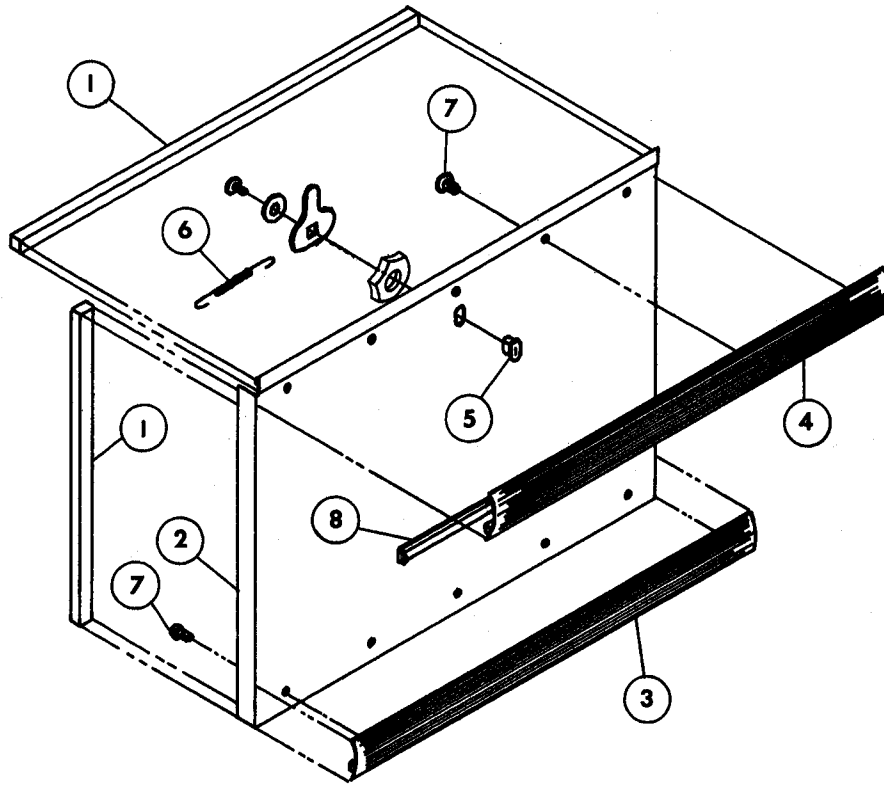

DROP LINT DOOR ASSEMBLY

<u>Illus. No.</u>	<u>Part No.</u>	<u>Qty.</u>	<u>Description</u>
1	117600	3	Noise Suppressor (sold in feet)
2	800234*	1	285 Insulated Drop Lint Door Assembly (less lock)
	108120	1	Chain for Drop Lint Door (sold in feet)
3	300009	1	Kick Trim (28")
4	300204	1	Middle Trip (28")
5	160001	1	AD-100 Lock Assembly
	160008	1	Lock Cam
	160103	1	AD-100 Key Only
6	157000	1	Spring
7	150201	10	10/32 x 1/4" Phil. R.H. Machine Screw

\* Specify color when ordering.

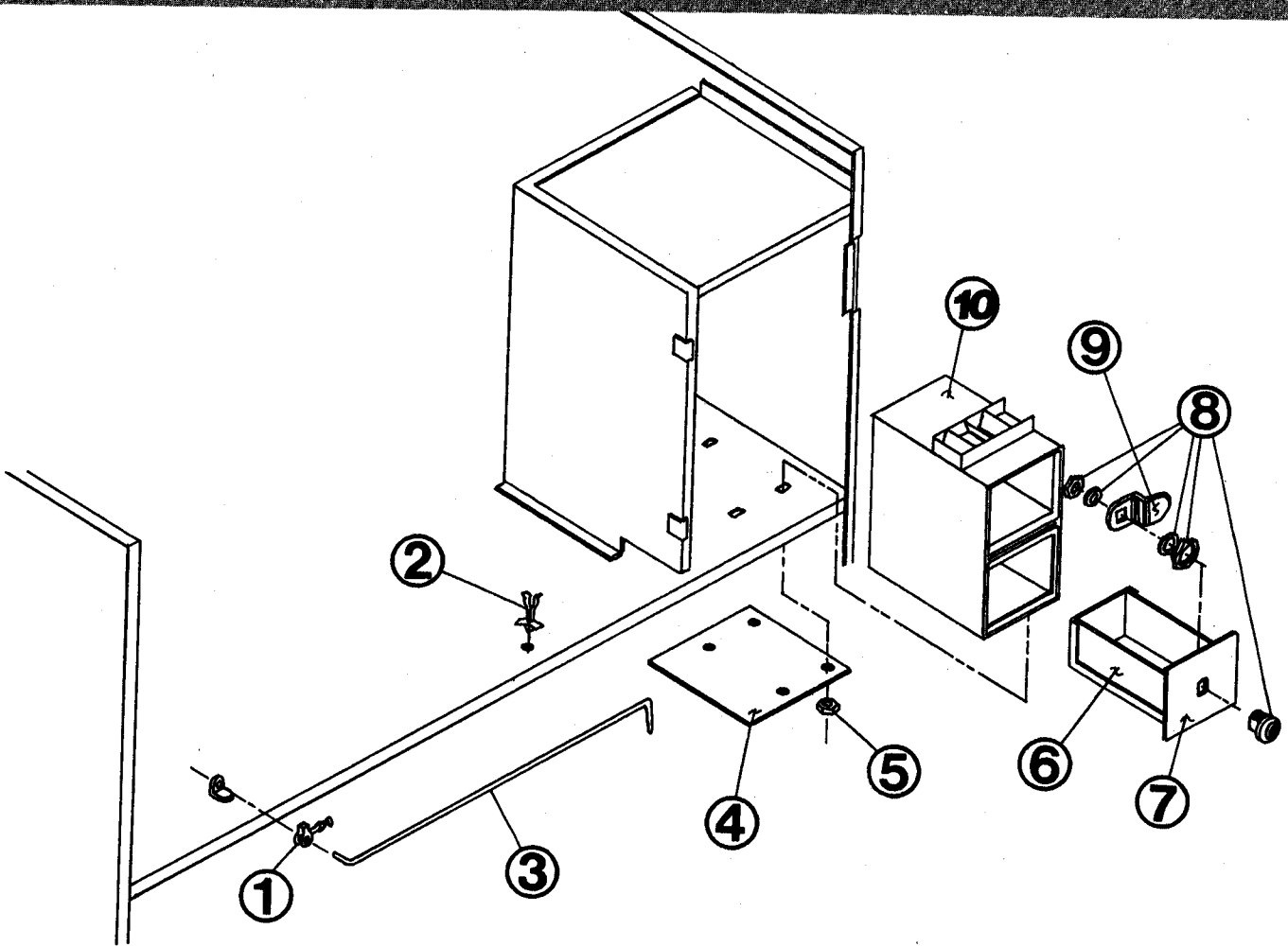

COIN VAULT ASSEMBLY

<u>Illus. No.</u>	<u>Part No.</u>	<u>Qty.</u>	<u>Description</u>
1	102601	1	Rod Retainer Clip
2	102600	1	Support Rod Catch
3	102503	1	Control Door Rod
4	309250	1	Coin Vault Slot Cover
5	152014	4	1/4-20 Free Spin Nut
6	802020	1	Coin Box Assembly Complete with Faceplate and Lock
	802019	1	Coin Box Only
7	802018	1	Face Plate Only
8	160007	1	1/4 Turn Coin Box Lock with Key
	160105*	1	1/4 Turn Mer-Pel Key Only
9	160006	1	Lock Cam Only
10	802121	1	Computer Coin Vault Only
	802120	1	Non-computer Coin Vault Only
	802131	1	Computer Coin Vault Assembly Complete
	802130	1	Non-computer Coin Vault Assembly Complete

\* Specify key number when ordering.

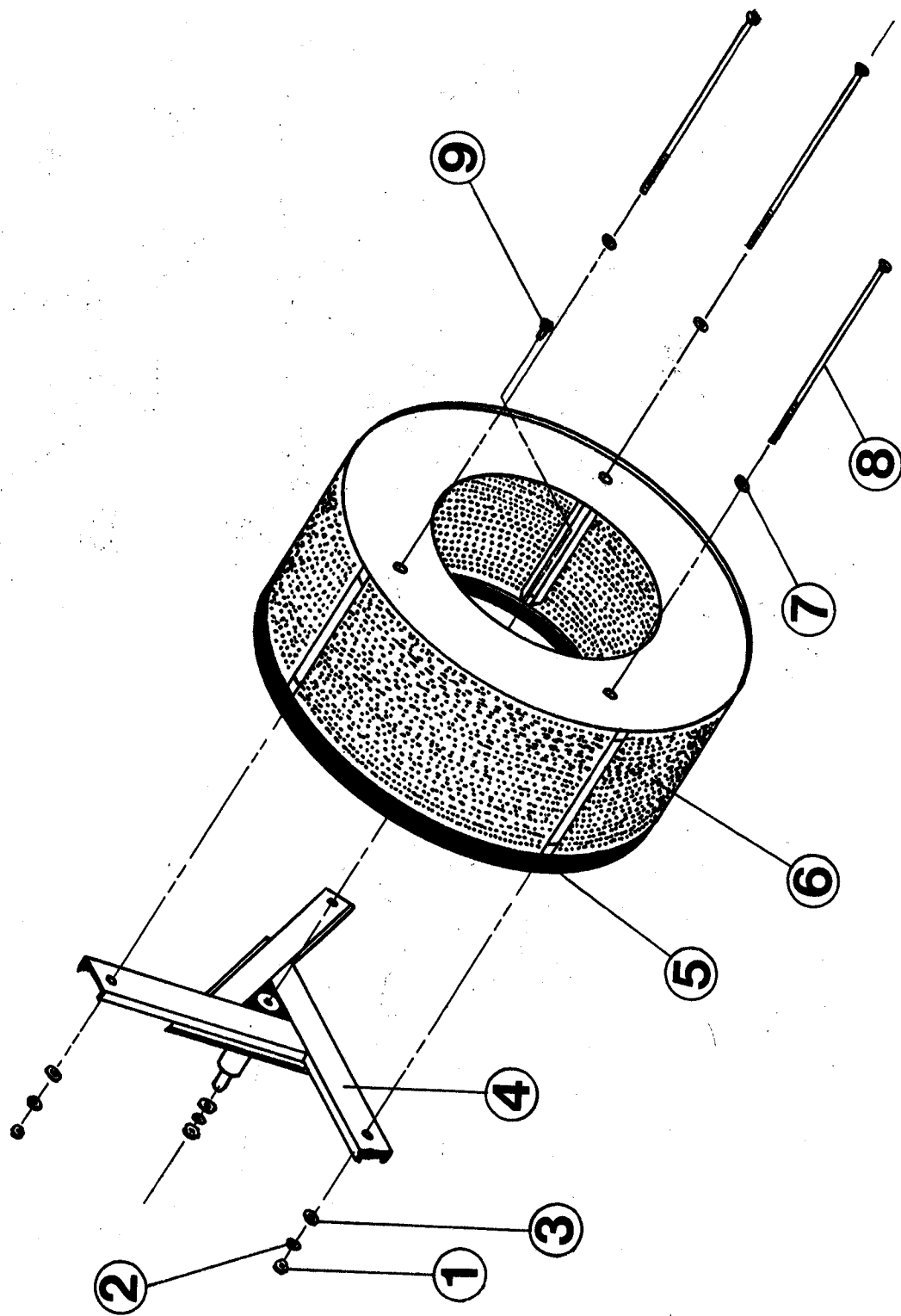

TUMBLER/SUPPORT ASSEMBLY

<u>Illus.</u> <u>No.</u>	<u>Part</u> <u>No.</u>	<u>Qty.</u>	<u>Description</u>
1	152004	3	5/16 Hex Nut
2	153002	3	5/16 Lock Washer
3	153001	3	5/16 Flat Washer
4	800612	1	285 Tumbler Support Only
5	116003	1	Felt Collar Only
	401010	-	#847 Adhesive for Felt Collar
6	800709	1	Tumbler Only*
	800853	1	Stainless Steel Tumbler Only*
	800815	1	Tumbler and Support Complete*
	800863	1	Stainless Steel Tumbler and Support Complete*
7	153003	3	3/8" Fender Washer
8	100902	3	5/16"018 x 31" Tie Rod
9	150518	1	5/16"-18 x 3/8" Soc. Screw

\* Felt collar not included.

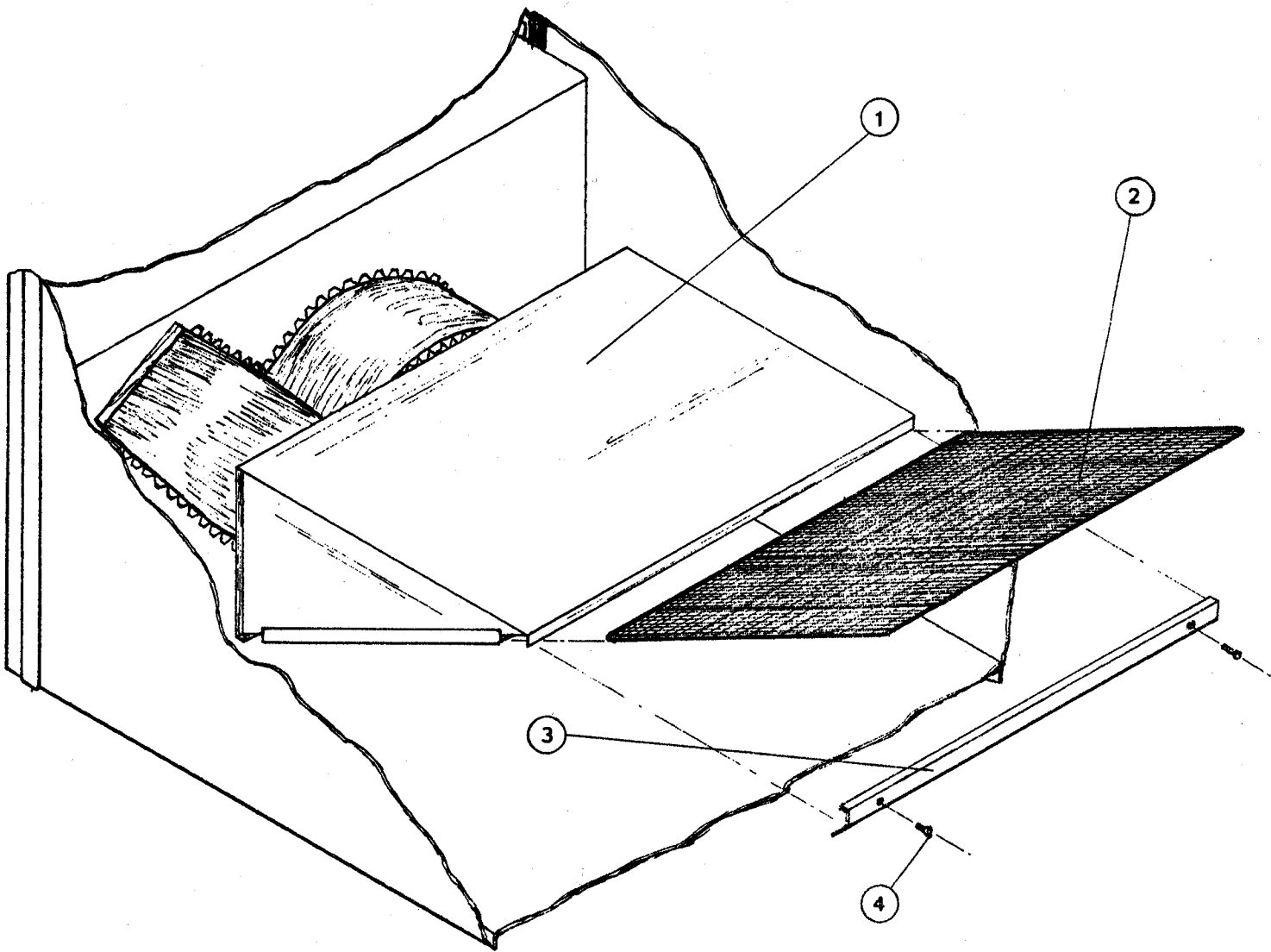

### LINT TRAP ASSEMBLY

<u>Illus. No.</u>	<u>Part No.</u>	<u>Qty.</u>	<u>Description</u>
1	800411	1	Lint Trap Only
	800410	1	Lint Trap Assembly Complete
2	800503	1	Lint Screen
3	304102	1	Lint Screen Hold Down
4	150300	2	#10 x 1/2" S.D. Screw



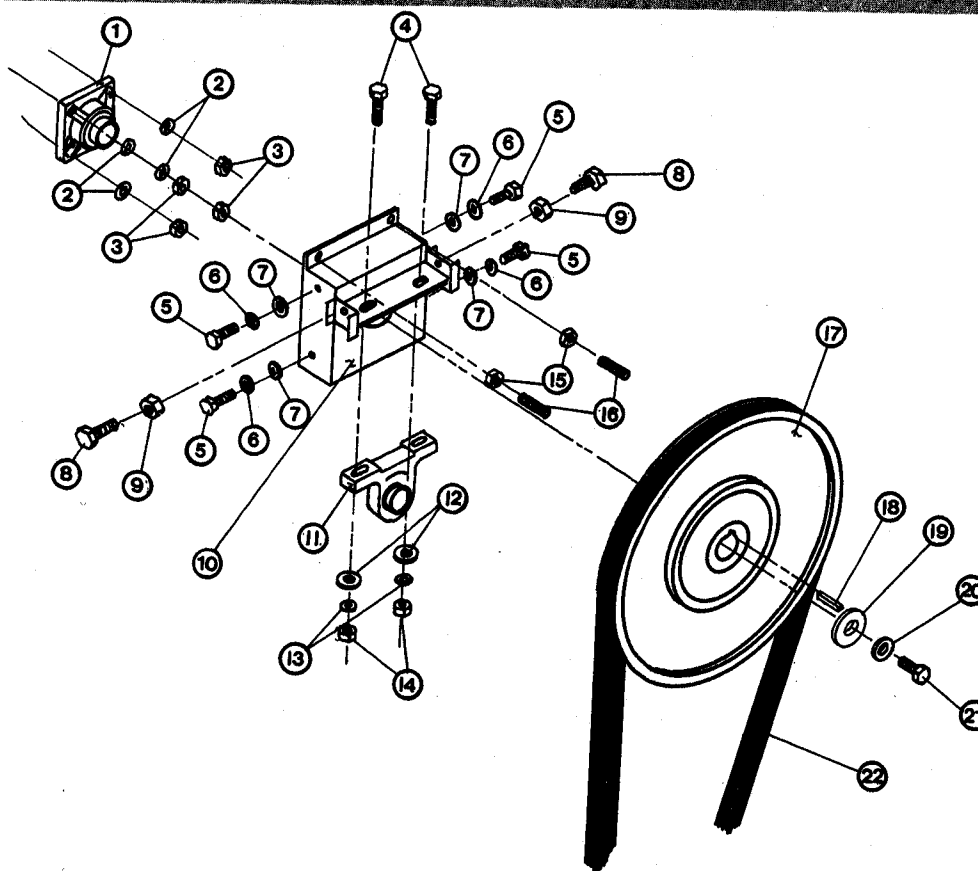

TUMBLER BEARING ASSEMBLY

<u>Illus. No.</u>	<u>Part No.</u>	<u>Qty.</u>	<u>Description</u>
1	100203	1	1-3/8" Flange Bearing
2	153005	4	3/8" Lock Washer
3	152005	4	3/8" Hex Nuts
4	150601	2	3/8"-16 x 2" H.H. Machine Bolt
5	150501	4	5/16"-18 x 3/4" H.H. Machine Bolt
6	153002	4	5/16" Lock Washer
7	153001	4	5/16" Flat Washer
8	150503	2	5/16"-18 x 2" H.H. Machine Bolt
9	152004	2	5/16"-18 Hex Nut
10	801101	1	1-3/8" Bearing Box Assembly Complete (including pillow block bearing and hardware)
11	100202	1	1-3/8" Pillow Block Bearing
12	153004	2	3/8" Flat Washer
13	153005	2	3/8" Lock Washer
14	152005	2	3/8"-16 Hex Nut
15	152004	2	5/16"-18 Hex Nut
16	150608	2	5/16"-18 x 1-1/4" Set Screw
17	101100	1	18" Pulley
18	100700	1	1/4" x 1/4" x 1" Key
19	153003	1	3/8" Fender Washer
20	153002	1	5/16" Lock Washer
21	150501	1	5/16"-18 x 3/4" H.H. Machine Bolt
22	100111	1	5L-650 V-Belt (tumbler to idler)

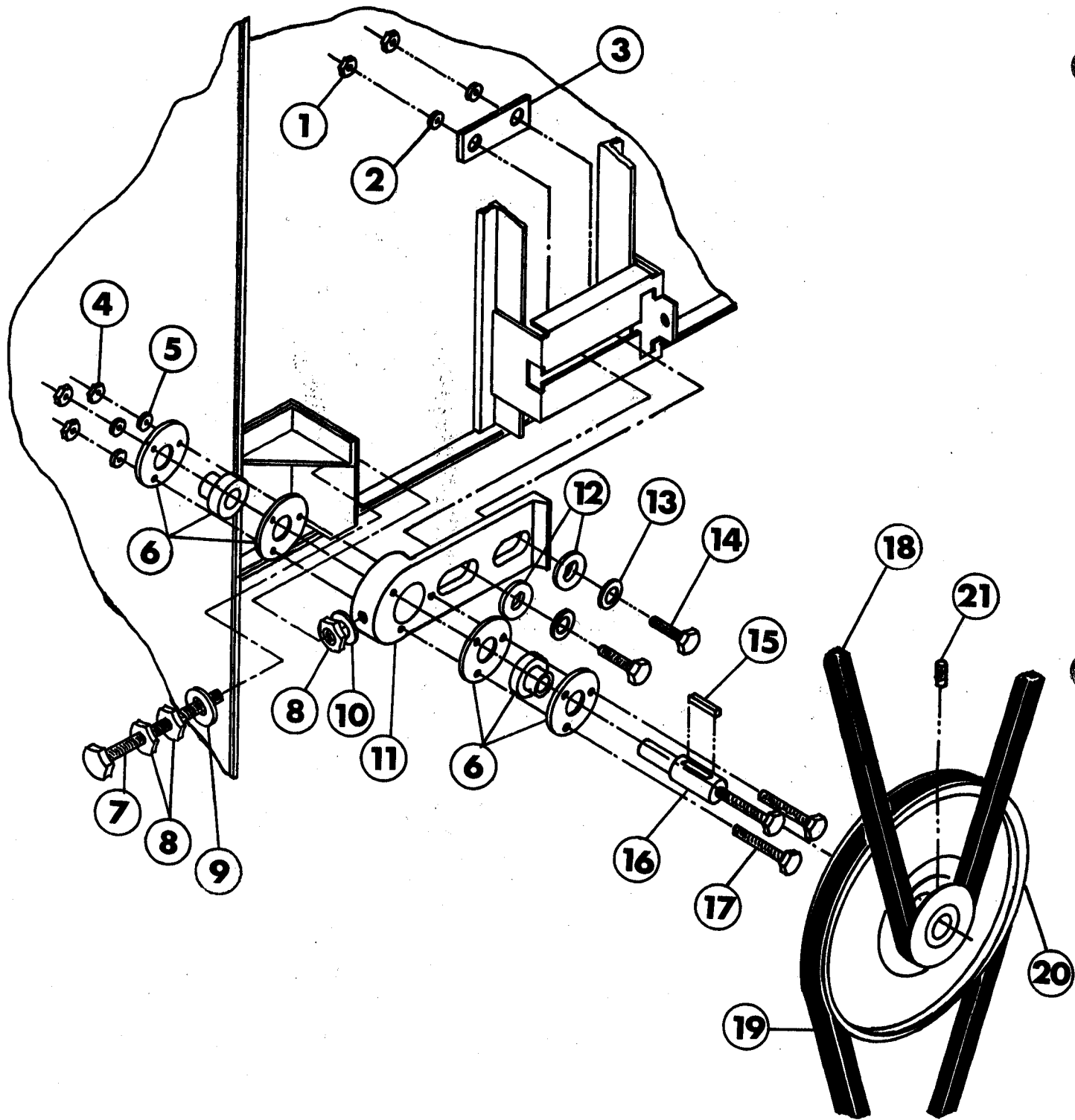

IDLER BEARING ASSEMBLY

<u>Illus.</u> <u>No.</u>	<u>Part</u> <u>No.</u>	<u>Qty.</u>	<u>Description</u>
1	152005	2	3/8" Hex Nut
2	153005	2	3/8" Lock Washer
3	311612	1	Square Washer
4	152002	3	1/4"-20 Hex Nut
5	153007	3	1/4" Lock Washer
6	100214	2	5/8" Flange Bearing
7	150613	1	5/16"-18 x 4" H.H. Machine Bolt
8	152004	3	5/16"-18 Hex Nut
9	153001	1	5/16" Flat Washer
10	153002	1	5/16" Lock Washer
11	100404	1	285 Idler Bearing Mount Only
	801008	1	285 Idler Assembly Complete
12	153003	2	3/8" Fender Washer
13	153004	2	3/8" Flat Washer
14	150600	2	3/8"-16 x 1-1/2" H.H. Machine Bolt
15	100708	1	3/16" x 3/16" x 2-1/16" Key
16	100403	1	5/8" x 3/4" Idler Shaft
17	150521	3	1/4"-20 x 2" Carriage Bolt
18	100111	1	5L-650 V-Belt (tumbler to idler)
19	100103	1	4L-510 V-Belt (motor to idler)
20	101129	1	9" x 2-1/2" Pulley
21	154301	2	5/16"-18 x 5/16 Set Screw

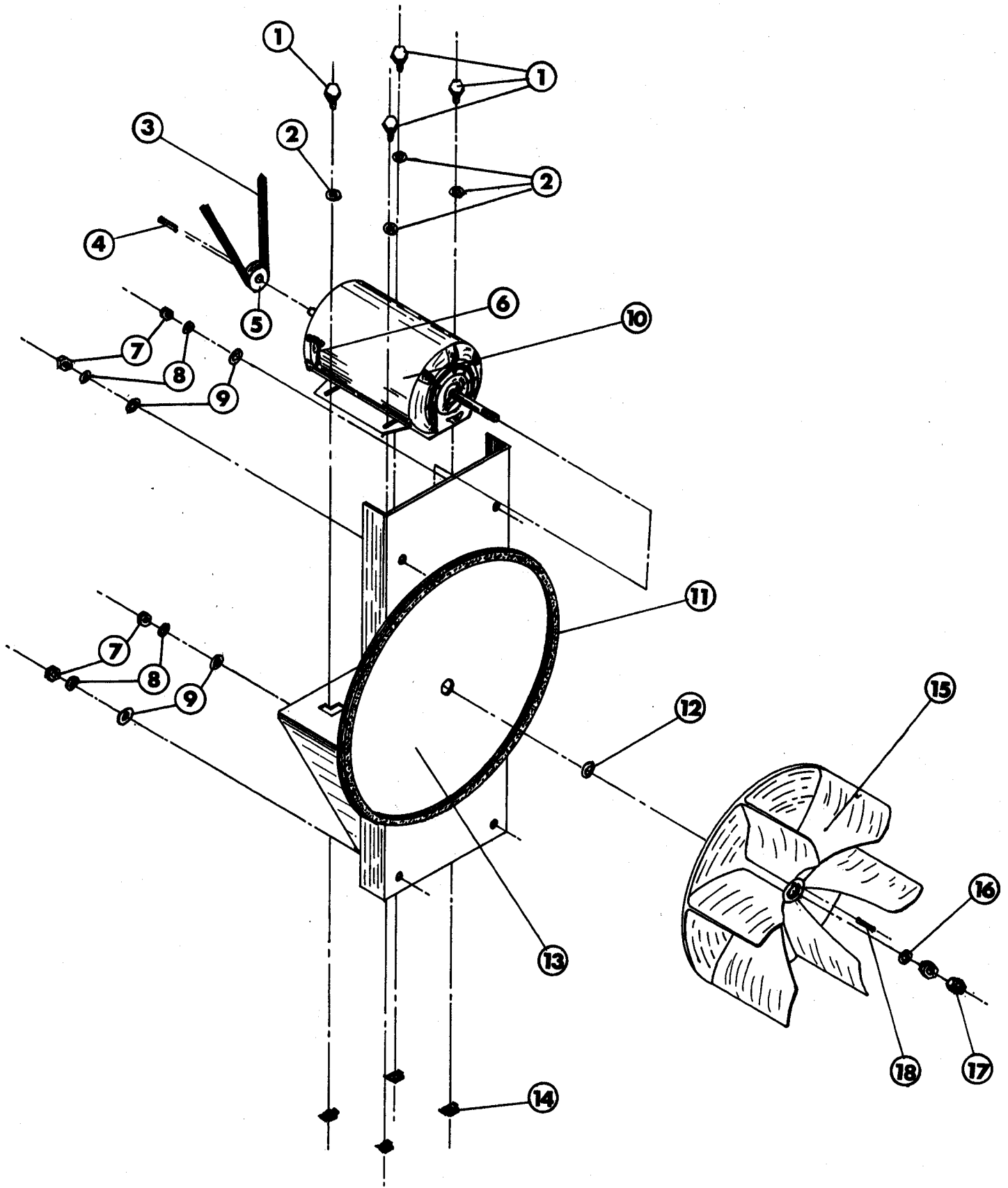

STANDARD MOTOR MOUNT ASSEMBLY

<u>Illus. No.</u>	<u>Part No.</u>	<u>Qty.</u>	<u>Description</u>
1	150501	4	5/16"-18 x 3/4" H.H. Machine Bolt
2	153002	4	5/16" Lock Washer
3	100103	1	4L-510 V-Belt (motor to idler)
4	100701	1	3/16" x 3/16" x 1" Key
5	101104	1	1/2" x 2" Motor Pulley (60HZ only)
	101133	1	5/8" x 2-1/4" Motor Pulley (50HZ only)
	101132	1	5/8" x 2" Motor Pulley (3Ph/60HZ)
6	120200	1	3/8"-90 <sup>0</sup> Connector
7	152004	4	5/16"-18 Hex Nut
8	153002	4	5/16" Lock Washer
9	153001	4	5/16" Flat Washer
10	100010	1	1/2HP, 115/230V, 1Ph (48Z) Motor (60HZ only)
	100007	1	1/2HP, 3Ph (56Z) Motor (50/60HZ)
	100035	1	1/2HP, 240V, 1Ph (56Z) Motor (50HZ only)
	117600	4 Ft.	Gasket (sold in feet)
12	153006	2	1/2" Spec Motor Washer
13	800901	1	Motor Mount only 48Z Frame (60HZ only)
	800909	1	Motor Mount only 56Z Frame (50HZ and 3Ph)
	803920*	1	1/2HP, 115/230V., 1Ph (48Z) motor-mount assembly complete (60HZ only)
	803924	1	1/2HP, 240V, 1Ph (56Z) motor-mount assembly complete (50HZ only)
	803793*	1	1/2HP, 3Ph (56Z) motor-mount assembly complete (60HZ only)
	803792*	1	1/2HP, 3Ph (56Z) motor-mount assembly complete (50HZ only)
14	154000	4	5/16"-18 Tinnerman Nut
15	100604	1	12.5" Plastic Fan
16	153006	2	1/2" Spec. Motor Washer
17	152006	2	1/2"-20 L.H. Jam Nut
18	100702	1	1/8" x 1/8" x 1-1/2" Key (56Z frame motors only)

\* Specify voltage.

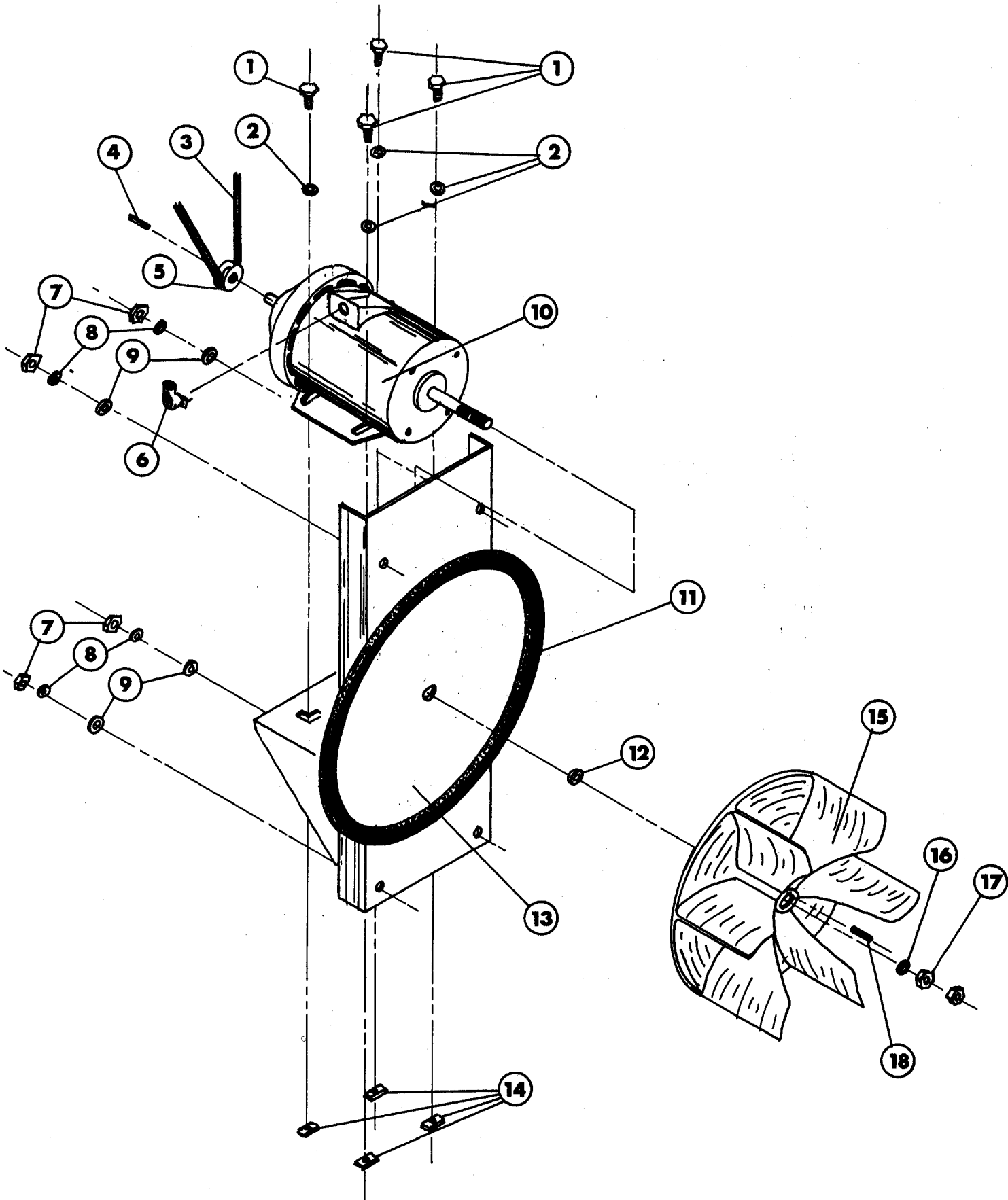

TOTALLY ENCLOSED FAN-COOLED MOTOR MOUNT ASSEMBLY

<u>Illus. No.</u>	<u>Part No.</u>	<u>Qty.</u>	<u>Description</u>
1	150501	4	5/16"-18 x 3/4 H.H. Machine Bolt
2	153002	4	5/16" Lock Washer
3	100103	1	4L-510 V-Belt (motor to idler)
4	100701	1	3/16" x 3/16 x 1" Key
5	101104	1	1/2" x 2" Motor Pulley (60HZ only)
	101131	1	1/2" x 2-1/4" Motor Pulley (50HZ only)
6	120300	1	3/8"-45° Connector
7	152004	4	5/16"-18 Hex Nut
8	153002	4	5/16" Lock Washer
9	153001	4	5/16" Flat Washer
10	100004	1	1/2HP, 115/230V, 1Ph (56Z) 50/60HZ Totally Enclosed Fan-cooled Motor
11	117600	4	Ft. Gasket (sold in feet)
12	153006	2	1/2" Spec. Motor
13	800909	1	Motor Mount only 56Z Frame
	803880*	1	1/2HP, 115/230V, 1Ph (T.E.F.C.) motor-mount assembly complete (60HZ only)
	803881*	1	1/2HP, 230/240V, 1Ph (T.E.F.C.) motor-mount assembly complete (50HZ only)
14	154000	4	5/16"-18 Tinnerman Nut
15	100604	1	12.5" Plastic Fan
16	153006	2	1/2" Spec. Motor Washer
17	152006	2	1/2"-20 L.H. Jam Nut

\* Specify Voltage

Bottom view of  
Manual Reset Thermostat →

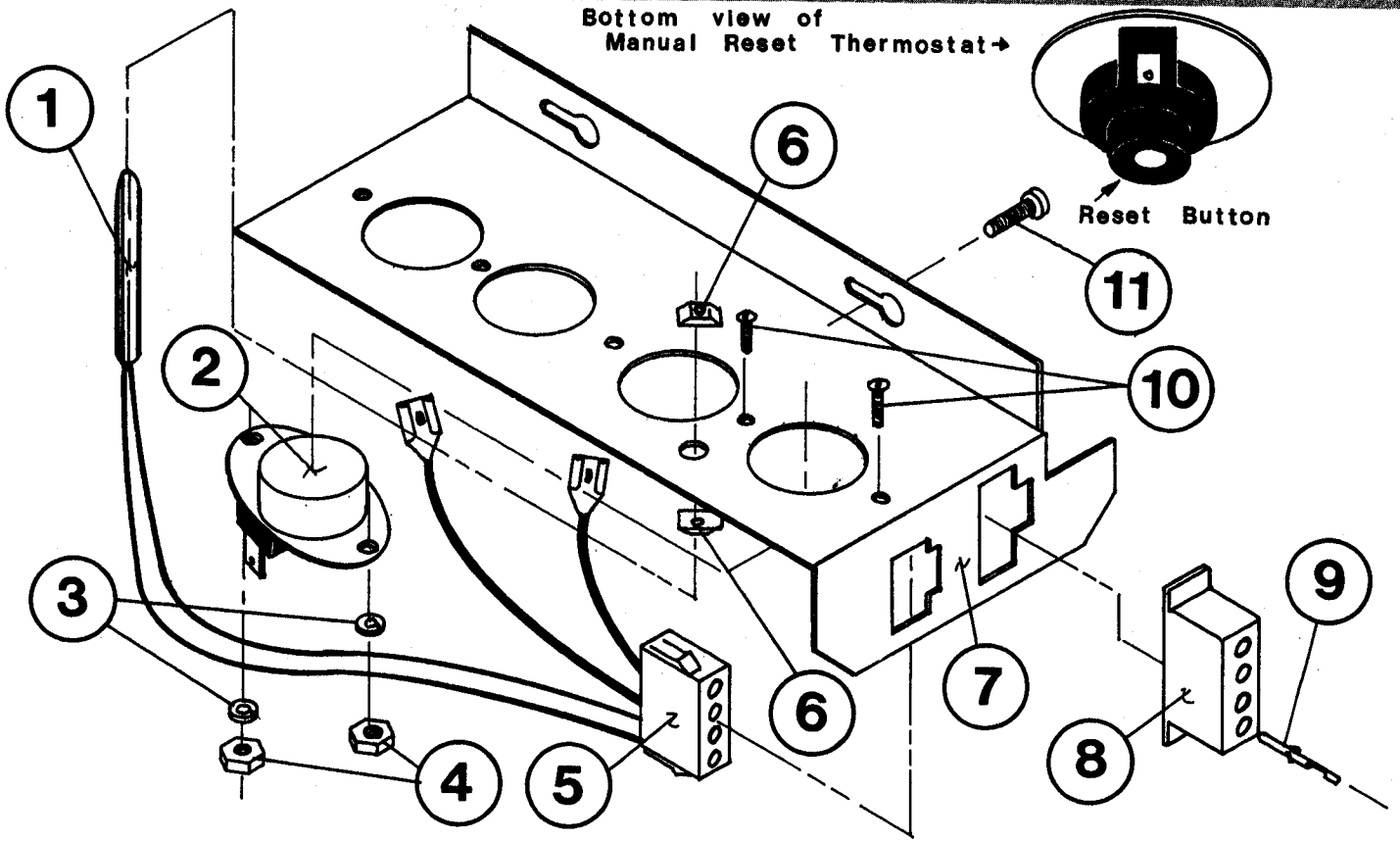

Bottom view of  
Manual Reset Thermostat →

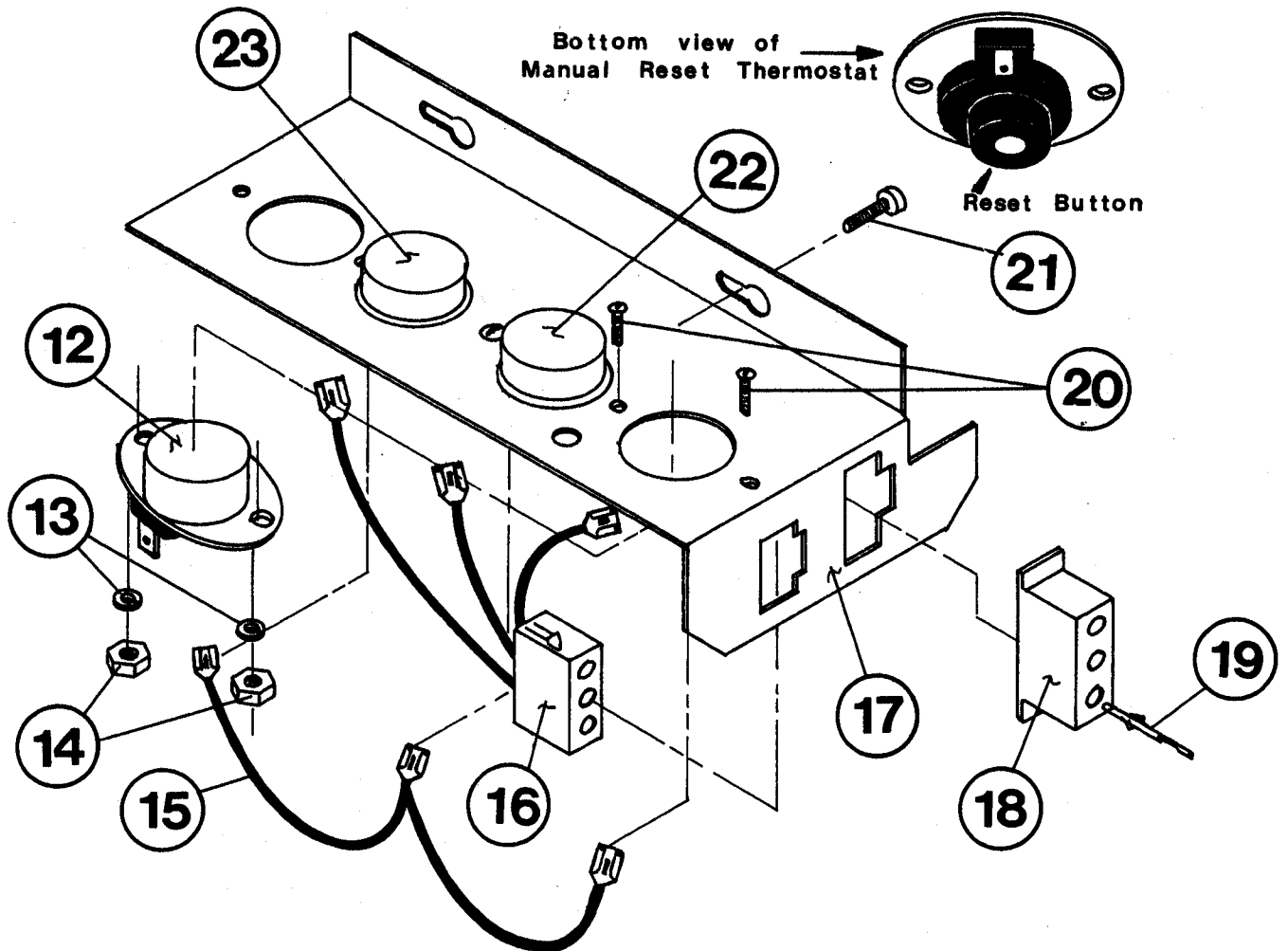



SENSOR BRACKET ASSEMBLIES

<u>Illus.</u> <u>No.</u>	<u>Part</u> <u>No.</u>	<u>Qty.</u>	<u>Description</u>
1	880251	1	Micro-processor Temperature Sensor Probe Assembly
2	130103	1	225° Automatic Reset Thermostat
	130301	1	225° Manual Reset Thermostat
3	153010	2	#6 Star Washer
4	152000	2	6/32 Hex Nut
5	122605	1	4-Pin Socket Connector Only
	122701	4	Socket Terminal Only
6	154007	2	1/4" Push-on Fastener
7	305007	1	Sensor Bracket Only
	801425	1	Micro-processor Sensor Bracket Assembly Complete
8	122604	1	4-Pin Connector Only
9	122700	4	Pin Terminal Only
10	150000	2	6/32 x 1/4" R.H. Machine Screw
11	150301	2	8-18 x 7/16" Phil Hd. TEK Screw
12	130103	1	225° Automatic Reset Thermostat
	130301	1	225° Manual Reset Thermostat
13	153010	4	#6 Star Washer
14	152000	4	6/32" Hex Nut
15	831700	1	Sensor Jumper (3)
16	122609	1	3-Pin Socket Connector Only
	122701	3	Socket Terminal Only
	831702	1	3-Pin Socket Harness Assembly (3)
17	305007	1	Sensor Bracket Only
	801405	1	Sensor Bracket Assembly Complete
18	122608	1	3-Pin Connector Only
19	122700	3	Pin Terminal Only
20	150000	4	6/32" x 1/4" R.H. Machine Screw
21	150301	2	8-18 X 7/16" Phil. Hd. TEK Screw
22	130101	1	180° Thermostat
23	130100	1	150° Thermostat

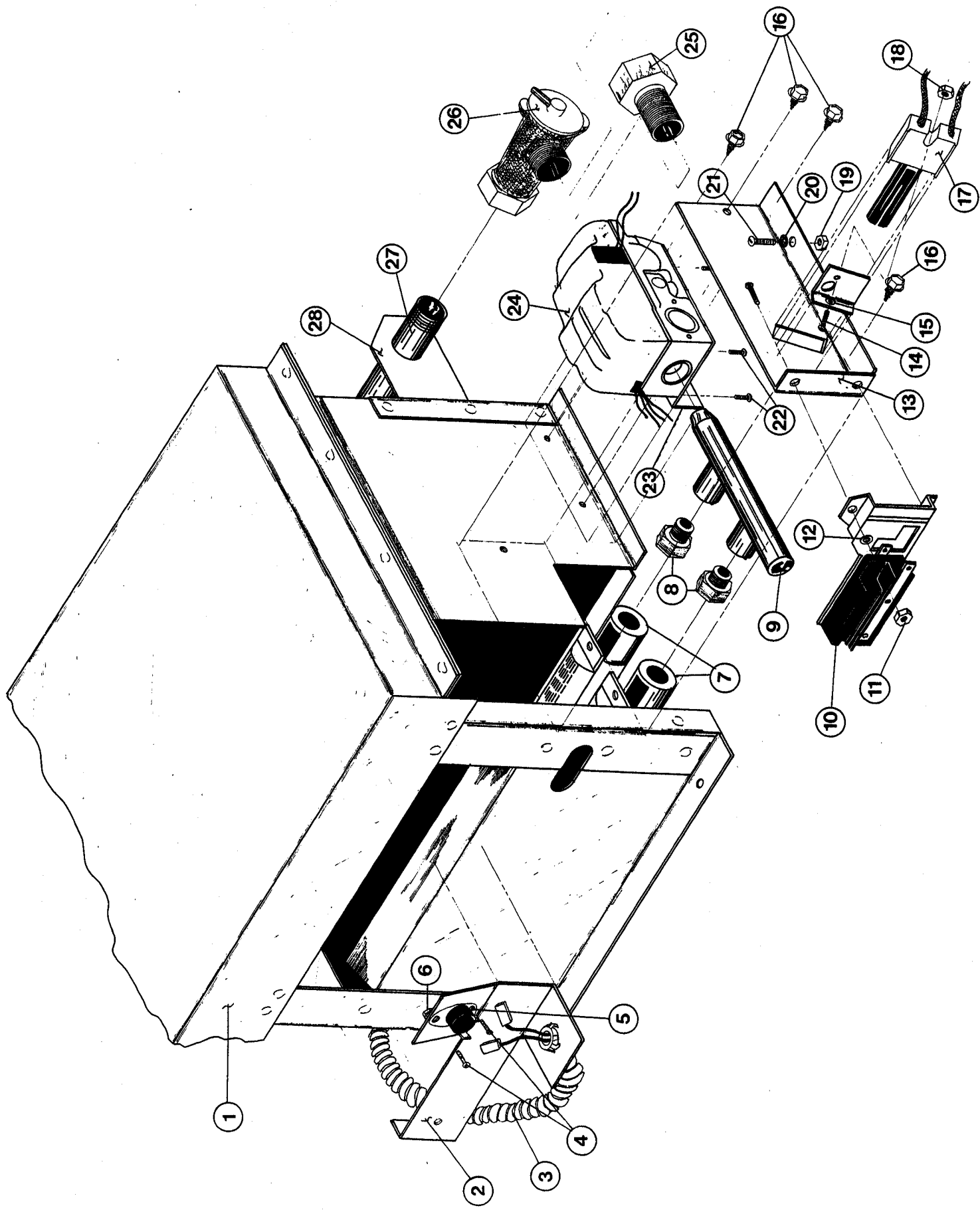

285 STANDARD (NON-COMPUTER) BURNER ASSEMBLY

<u>Illus.</u> <u>No.</u>	<u>Part</u> <u>No.</u>	<u>Qty.</u>	<u>Description</u>
1	804010	1	Heat Reclaimer Burner Box and Bonnet Only
	809544	1	Standard Glo-bar Burner (natural) Assembly Complete (less orifice)
	809549	1	Standard Glo-bar Burner (L.P.) Assembly Complete (less orifice)
2	319704	1	Hi-limit Mounting Bracket Only
3	830116	1	285 Hi-limit Harness
4	150001	2	6/32 x 1/2" R.H. Machine Screw
5	130401	1	330 <sup>0</sup> Hi-limit
6	151000	2	6/32 Pal Nut
7	141104	2	Small Tube Burner
8	140851*	2	#32 Burner Orifice (natural gas only)
	140802*	2	#50 Burner Orifice (L.P. gas only)
9	141206	1	3/8" Manifold
10	130500	1	IR Sensor
11	152001	1	8/32 Hex Nut
12	153012	1	#8 Star Washer
13	802705	1	IR/Glo-bar Mounting Bracket
14	150002	1	6/32 x 1" R.H. Machine Screw
15	153017	1	#6 Steel Burr
16	150300	4	#10 x 1/2" S.D. Screw
17	128910	1	Glo-bar
18	151000	1	6/32 Pal Nut
19	151001	2	8/32 Pal Nut
20	153000	2	#8 Steel Burr
21	150103	3	8/32 x 1/2" P.H. Machine Screw
22	150301	3	#8-18 x 7/16" Phil. TEK Screw
23	319501	1	Valve Mounting Bracket (3/8")
24	140004	1	3/8" Glo-bar Gas Valve (natural)
	140402	1	3/8" Valve L.P. Conversion Kit
25	141304	1	3/8" Union Tail Piece
26	141305	1	Union Shut-off Body Only
27	142809	2	1/2" x 29-1/8" Pipe
28	318700	2	Pipe Bracket

\* Contact factory for elevations over 2,000 feet.

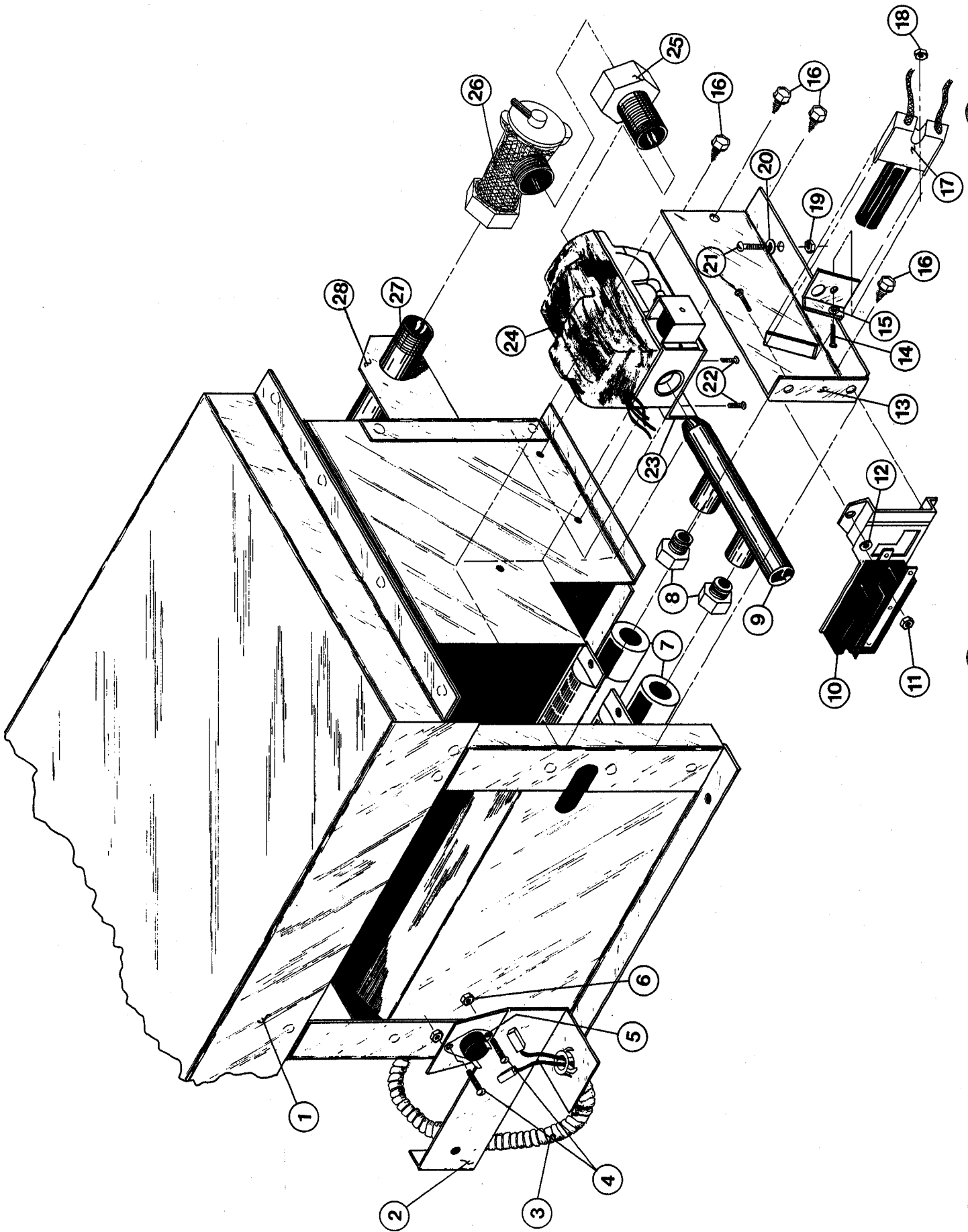

285 HI/LO COMPUTERIZED BURNER ASSEMBLY

<u>Illus.</u> <u>No.</u>	<u>Part</u> <u>No.</u>	<u>Qty.</u>	<u>Description</u>
1	804010	1	Heat Reclaimer Burner Box and Bonnet Only
	809592	1	Hi/Lo Burner (natural) Assembly Complete (less orifice)
	809602	1	Hi/Lo Burner (L.P.) Assembly Complete (less orifice)
2	319704	1	Hi-limit Mounting Bracket Only
3	830116	1	285 Hi-limit Harness
4	150001	2	6/32 x 1/2" R.H. Machine Screw
5	130401	1	330 <sup>0</sup> Hi-limit
6	151000	2	6/32 Pal Nut
7	141104	2	Small Tube Burner
8	140819*	2	#30 Burner Orifice (natural gas only)
	140800*	2	#52 Burner Orifice (L.P. gas only)
9	141206	1	3/8" Manifold
10	130500	1	IR Sensor
11	152001	1	8/32 Hex Nut
12	153012	1	#8 Star Washer
13	802705	1	IR/Glo-bar Mounting Bracket
14	150002	1	6/32 x 1" R.H. Machine Screw
15	153017	1	#6 Steel Burr
16	150300	4	#10 x 1/2" S.D. Screw
17	128910	1	Glo-bar
18	151000	1	6/32 Pal Nut
19	151001	2	8/32 Pal Nut
20	153000	2	#8 Steel Burr
21	150103	3	8/32" x 1/2" P.H. Machine Screw
22	150301	3	#8-18 x 7/16" Phil. TEK Screw
23	319501	1	Valve Mounting Bracket
24	140009	1	3/8" (natural) Hi/Lo Gas Valve
	800038	1	3/8" (L.P.) Hi/Lo Gas Valve
25	141304	1	3/8" Union Tail Piece
26	141305	1	Union Shut-off Body Only
27	142809	1	1/2" x 29-1/8" Pipe
28	318700	2	Pipe Brackets

\* Consult factory for elevations over 2,000 feet.

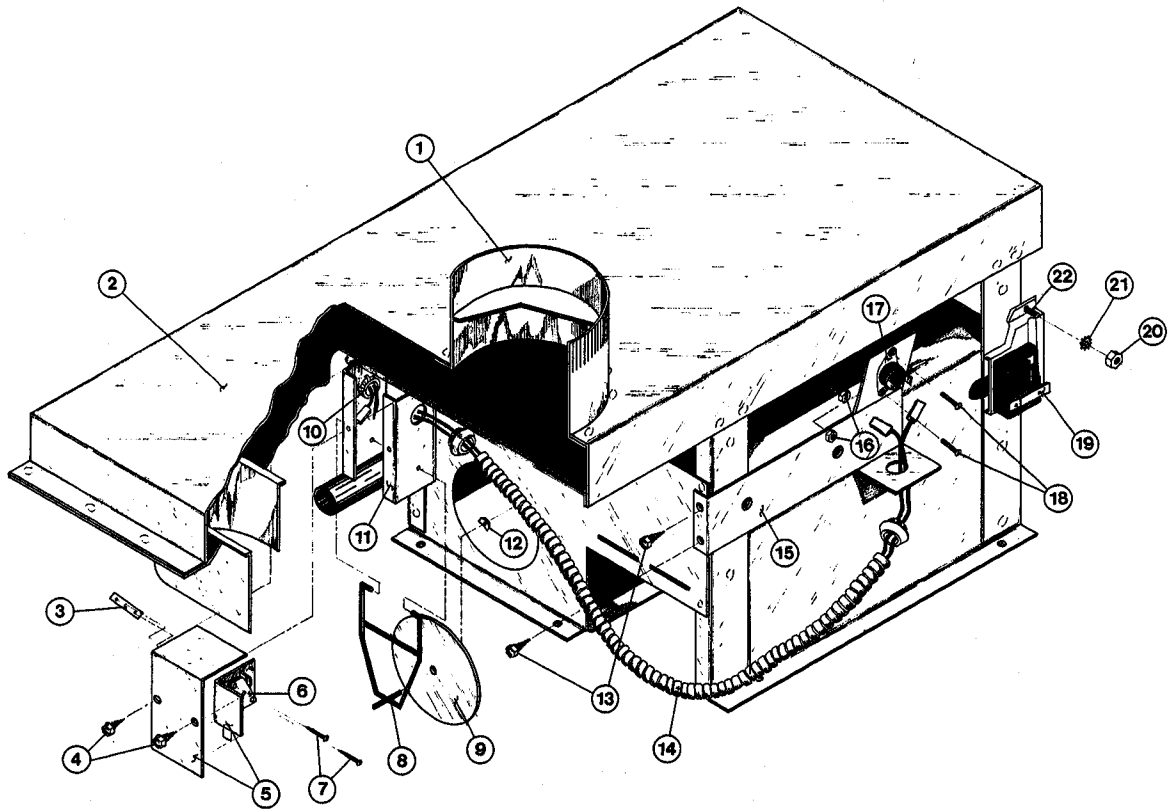

SAIL SWITCH/HI-LIMIT ASSEMBLY

<u>Illus. No.</u>	<u>Part No.</u>	<u>Qty.</u>	<u>Description</u>
1	880502	1	6" Damper Replacement
2	809592	1	Heat Reclaimer Burner Box and Bonnet Only
3	154004	1	Twin Speed Nut
4	150300	2	#10 x 1/2" S.D. Screw
5	802799	1	Sail Switch Box Cover and Bracket Only
6	122200	1	Sail Switch
7	150303	2	#4 x 3/4" "A" P.H. Machine Screw
8	105500	1	Sail Switch Damper
9	319202	1	Sail Switch Harness
10	840055	1	285 Sail Switch Harness
11	802800	1	Sail Switch Box with Cover and Bracket
	802801	1	Sail Switch Box Assembly Complete
12	154002	1	1/8" Push-on Fastener
13	150300	2	#10 x 1/2" S.D. Screw
14	830116	1	285 Hi-limit Harness
15	319704	1	Hi-limit Mounting Bracket Only
16	151000	2	6/32 Pal Nut
17	130401	1	330 <sup>0</sup> Hi-limit
18	150001	2	6/32 x 1/2" R.H. Machine Screw
19	130500	1	IR Sensor
20	152001	1	8/32 Hex Nut
21	153012	1	#8 Star Washer
22	150103	1	8/32 x 1/2" P.H. Machine Screw

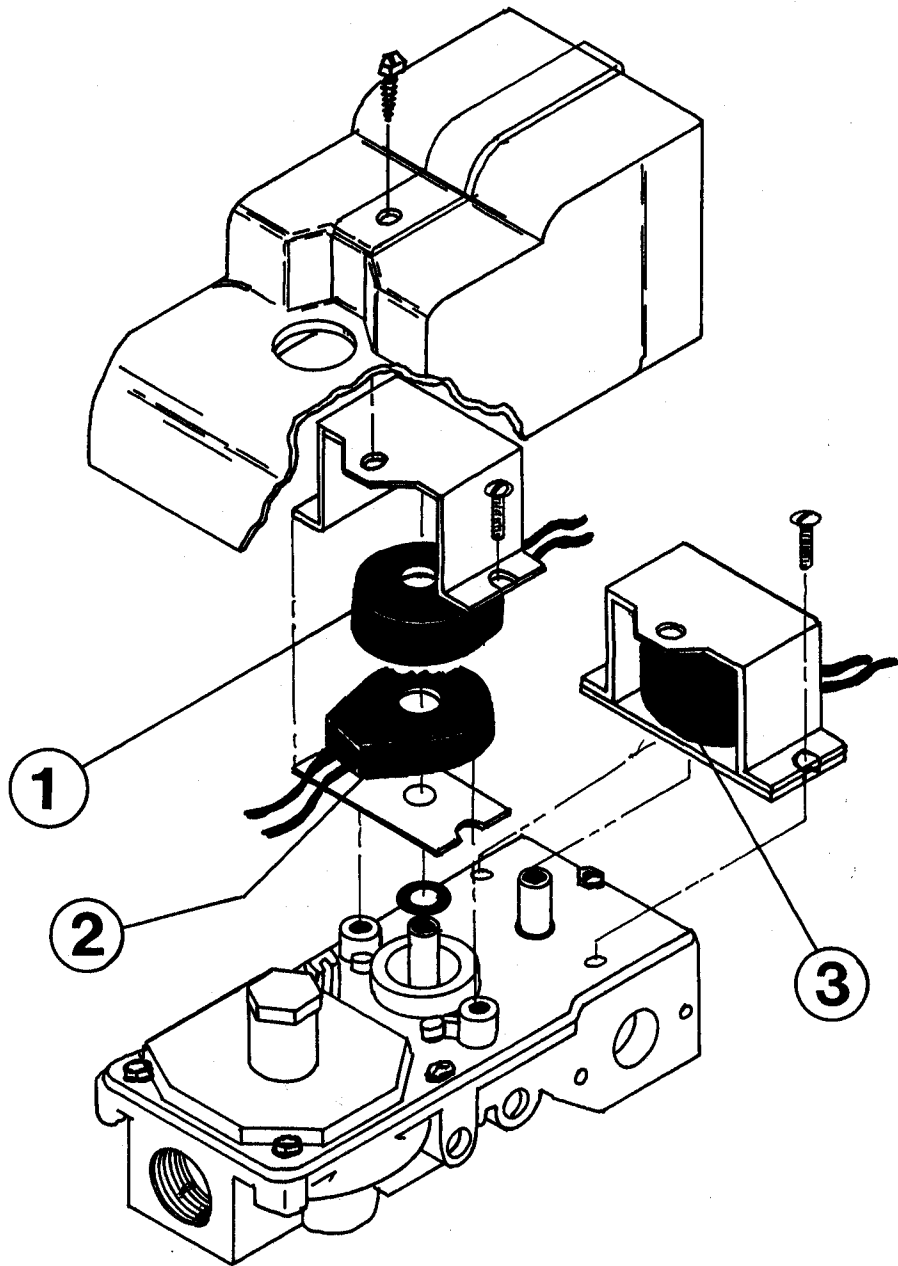

REPLACEMENT COILS FOR 3/8" NON-HI/LO GAS VALVE

<u>Illus. No.</u>	<u>Part No.</u>	<u>Qty.</u>	<u>Description</u>
1	140111	1	Holding Coil
2	140112	1	Booster Coil
3	140110	1	Secondary Coil

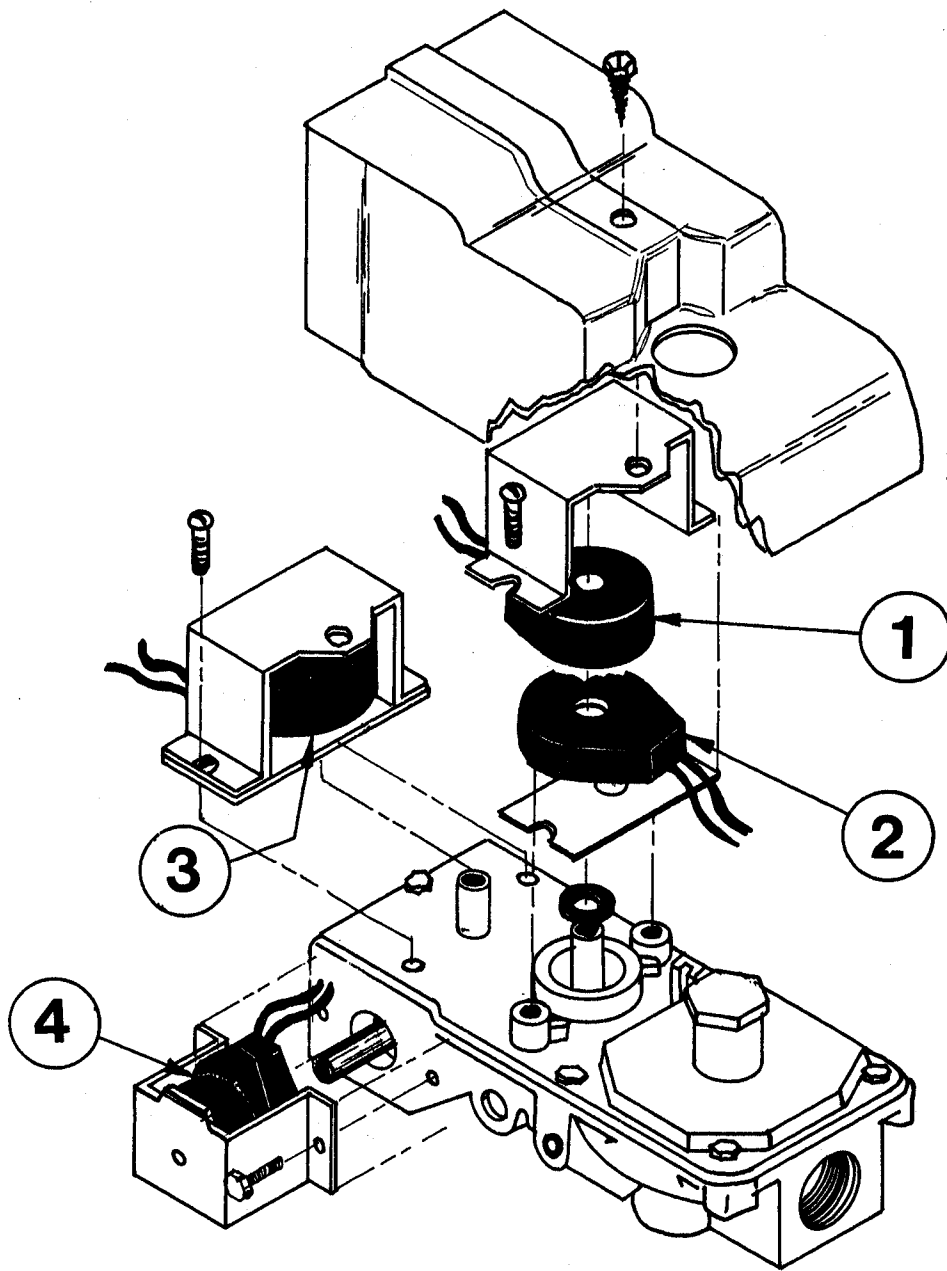

REPLACEMENT COILS FOR 3/8" HI/LO GAS VALVE

<u>Illus. No.</u>	<u>Part No.</u>	<u>Qty.</u>	<u>Description</u>
1	140116	1	Holding Coil
2	140115	1	Booster Coil
3	140117	1	Secondary Coil
4	140118	1	Hi/lo Coil



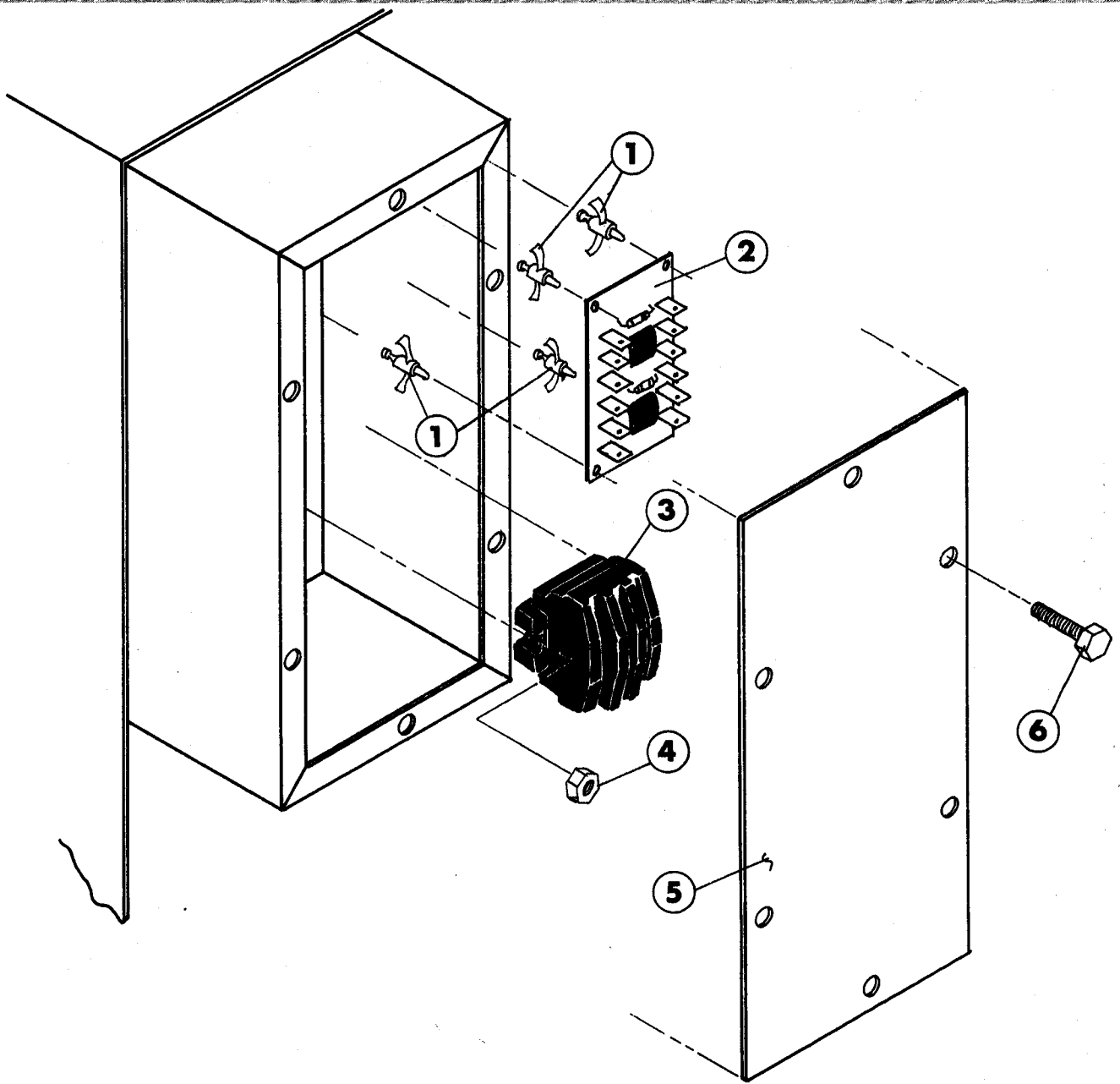

### 3-PHASE ELECTRIC RELAY PANEL ASSEMBLY

<u>Illus. No.</u>	<u>Part No.</u>	<u>Qty.</u>	<u>Description</u>
1	137013*	4	Nylon Stand-off
2	137060*	1	A.S. Board (3)
3	132400	1	Impellor Contactor
4	151001	2	8/32 Pal Nut
5	311913	1	Service Box Cover Plate
6	150300	6	#10 x 1/2" S.D. Screw

\* 3-phase computer models only.

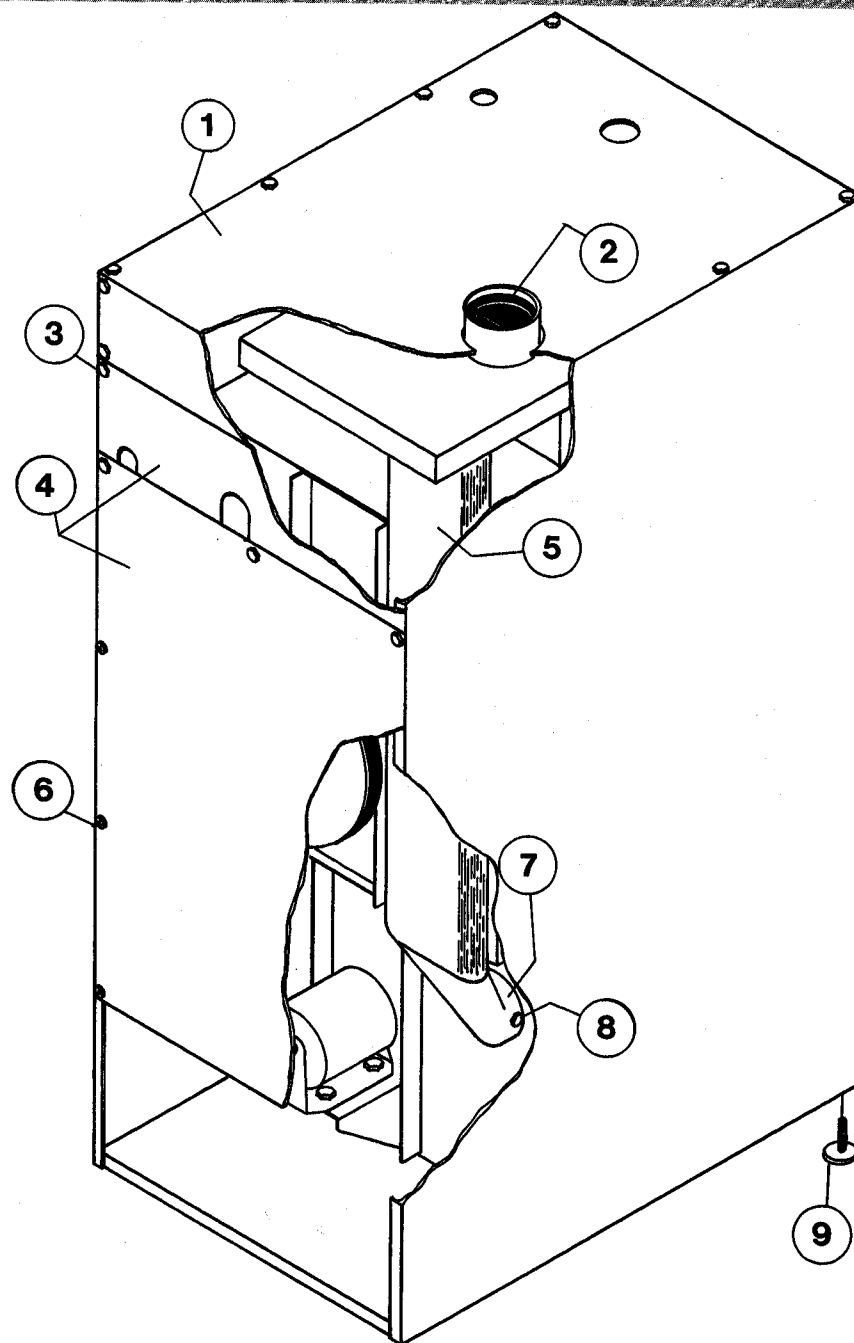

OUTER TOP/BACK GUARD ASSEMBLY

<u>Illus. No.</u>	<u>Part No.</u>	<u>Qty.</u>	<u>Description</u>
1	303620	1	285 Outer Top
2	880502	1	6" Damper Replacement
3	150300	17	#10 x 1/2" S.D. Screw
4	330626	1	285 Back Guard (2-piece)
5	143517	1	42" Long Oval Duct
6	150301	6	#8-18 x 7/16" Phil. TEK Screw
7	143515	1	90° Boot Round to Oval
8	150300	2	#10 x 1/2" S.D. Screw
9	103500	4	Leveling Leg

ADDITIONAL PARTS AVAILABLE BUT NOT ILLUSTRATED

<u>Part No.</u>	<u>Description</u>
120800	In Line Connector (1/4")
120802	Red Butt Connector
120902	74B Wire Nut
120903	Crimp-on Wire Nut
121014	1/4" Insulated Female Terminal
880200	Electrical Terminal Assortment Kit
121499	Harness Ties (4")
121500	Harness Ties (7")
121503	Harness Tie Mounting Clip
120600	3/8" Greenfield
120200	3/8" 90° Connector
120100	3/8" Straight Connector
120400	3/8" Red Jacket (BX Insulator)
120500	3/8" Jiffy Clip (BX Retainer Clip)
405500*	White Touch-up Paint
405502*	Cornflower Blue Touch-up Paint
405503*	Almond Touch-up Paint
405504*	Golden Wheat Touch-up Paint
405505*	Burnt Orange Touch-up Paint
405506*	Pearl Gray Touch-up Paint
405507*	Candy Apple Red Touch-up Paint
122800	Micro-processor Female Pin Extractor Tool
122801	Standard Male/Female Pin Extractor Tool
122804	Manometer (Water Column Test Gauge)

\* Touch-up paint sold in 1/2 pint containers.

## SECTION VII

### Trouble Shooting

The information provided will help isolate the most probable component(s) associated with the difficulty described. The experienced technician realizes, however, that a loose connection or broken or shorted wire may be at fault where electrical components are concerned...not necessarily the suspect component itself.

ELECTRICAL PARTS SHOULD ALWAYS BE CHECKED FOR FAILURE BEFORE BEING RETURNED TO THE FACTORY.

The information provided should not be misconstrued as a device for use by an untrained person in making repairs. Only properly licensed technicians should service the equipment.

Observe all safety precautions displayed on the equipment or specified in this manual while making repairs.

#### A. Mechanical Coin Meter Controls (Non-computer)

<u>Trouble</u>	<u>Probable Cause</u>
1. Dryer will not start.	a. Open circuit breaker switch or blown fuse. b. Faulty motor relay c. Faulty "Push to Start" relay d. Faulty coin meter e. Main door switch is out of adjustment or is defective. f. Faulty motor
2. Tumbler motor runs, the burner is on, but the tumbler will not revolve.	a. Broken, damaged, or loose V-belt b. Belts are contaminated (oil, grease, etc.) c. Loose or broken motor pulley
3. Dryer motor starts but the glo-bar is not lighting.	a. Manual reset thermostat in lint compartment has tripped or is defective. (models prior to October 1, 1985)

- b. Lint compartment automatic safety thermostat (225°) is defective. (models manufactured as of October 1, 1985)
  - c. Sail switch is out of adjustment, defective, or sail switch damper is not closing due to back pressure created by a restriction in the exhaust system.
  - d. Faulty glo-bar
  - e. Defective burner hi-limit (330°) safety thermostat
  - f. Defective coin meter switch
  - g. Faulty heat selector switch
  - h. Faulty I.R. sensor
  - i. Faulty gas valve
  - j. Ignition system transformer (208 or 230 volt controls only) is defective. Check for 115V across black and white wires of transformer.
4. Dryer operates. Glo-bar heats up and stays on.
5. Dryer operates. Glo-bar heats up and goes out, but gas does not flow.
6. Dryer operates. Glo-bar heats up and goes out, but burner does not light even though gas is evident.
- a. Faulty I.R. sensor
  - a. Dryer or external gas shut-off valve is closed.
  - b. Defective gas valve (open coil in gas valve)
  - c. For 208 or 230V controls, ignition transformer may not be wired correctly. Check wiring sequence for correct voltage application.
  - a. Gas pressure is too low. Check manifold pressure and adjust regulation accordingly.
  - b. Incorrect gas/air mixture.

- Adjust air shutters of each tube burner.
7. Dryer operates, but dryer is taking too long to dry.
- c. Insufficient make-up air
  - a. An inadequate exhaust duct work system.
  - b. Restriction in exhaust system.
  - c. Dryer exhaust damper is stuck partially closed.
  - d. Insufficient make-up air
  - e. Poor housekeeping....dirty or clogged lint screen.
  - f. Extractors are not performing properly.
  - g. An exceptionally cold/humid or low barometric pressure atmosphere
  - h. The gas may have a low heating value. Check with local gas supplier.
8. Dryer will not shut off.
- a. Defective motor relay (Contacts stuck in closed position.)
  - b. Defective coin meter switch (Switch contacts stuck in closed position.)
9. Motor keeps overheating.
- a. Either an exceptionally low or high voltage supply.
  - b. Motor bearing failure.
  - c. Motor thermal overload protector is defective.
  - d. An idler or tumbler bearing failure
  - e. Motor vents are blocked with lint.

10. Excessive noise or vibration in the dryer.

- f. Defective motor
- g. Insufficient make-up air
- a. Tumbler is out of alignment.
- b. V-belt is too loose or too tight.
- c. Loose or broken tumbler (basket/drum) tie rod
- d. Tumbler or idler bearing failure
- e. Tumbler adjustment bolts are loose.
- f. Loose motor mount
- g. Faulty impellor (fan)

11. Dryer is cycling on burner hi-limit thermostat.

- a. Insufficient exhaust duct work size or restriction in exhaust system.
- b. Insufficient make-up air
- c. Lint screen needs cleaning.
- d. Damaged impellor (fan)

12. Main burners are burning with a yellow flame.

- a. Burner air shutters need adjusting.
- b. Insufficient make-up air
- c. Dust or lint in the burners

## B. Computer Controls

### Trouble

1. No display

### Probable Cause

- a. Open circuit breaker switch or blown fuse
- b. A.S. board fuse(s) blown.
- c. Faulty A.S. board
- d. Faulty computer controller

2. Dryer will not start, but computer display indicators are on.
  - a. Top door switch (A.C.) is not adjusted properly or is defective.
  - b. Ignition transformer (208 or 230V controls only) is defective. Check for 115 Volts across black and white wires.
  - c. Faulty A.S. board motor relay
  - d. Faulty impellor contactor (relay) (3-phase models only)
  - e. Faulty coin controller (computer)
  - f. Faulty motor
  
3. Tumbler motor runs, burner is on, but tumbler will not revolve.
  - a. Broken, damaged, or loose v-belt
  - b. Belts are contaminated (oil, grease, etc.)
  - c. Loose or broken motor pulley.
  
4. Dryer motor starts, computer display heat indicators are on, but glo-bar is not lighting.
  - a. Manual reset thermostat in the lint compartment has tripped or is defective. (models prior to October 1, 1985)
  - b. Lint compartment automatic safety thermostat (225°) is defective. (models manufactured as of October 1, 1985)
  - c. Sail switch is out of adjustment, defective, or sail switch damper is not closing due to back pressure created by a restriction in the exhaust system.
  - d. Defective burner hi-limit (330°) safety thermostat
  - e. Defective glo-bar
  - f. Faulty A.S. board heat relay
  - g. Faulty gas valve



- h. Faulty I.R. sensor
  - i. Faulty coin controller (computer)
  
- 5. Dryer operates.  
Glo-bar heats up and stays on.
  - a. Faulty I.R. sensor
  
- 6. Dryer operates.  
Glo-bar heats up and goes out, but gas does not flow.
  - a. Dryer or external gas shut-off valve is closed.
  - b. Defective gas valve (open coil in valve)
  - c. For 208 or 230 volt controls, ignition transformer may not be wired correctly. Check wiring sequence for correct voltage application.
  
- 7. Dryer operates.  
Glo-bar heats up and goes out, but burner does not light even though gas is evident.
  - a. Gas pressure is too low. Check manifold pressure and take necessary corrective action.
  - b. Defective gas valve (hi/lo coil)
  - c. Incorrect gas/air mixture. Adjust air shutters of each burner.
  - d. Insufficient make-up air
  
- 8. Dryer operates, but is taking too long to dry.
  - a. An inadequate exhaust duct work system
  - b. Restriction in exhaust system
  - c. Dryer exhaust damper is stuck partially closed.
  - d. Insufficient make-up air
  - e. Poor housekeeping....dirty or clogged lint screen
  - f. Extractors are not performing properly.



- e. Faulty A.S. board heat relay
  - f. Faulty coin controller (computer)
  
- 12. Main burners are burning with a yellow flame.
  - a. Burner air shutters need adjusting.
  - b. Insufficient make-up air
  - c. Dust or lint in the burner
  
- 13. Display reads "dSFL", Dryer Sensor Circuit Failure.
  - a. Faulty micro-processor temperature sensor probe
  - b. Open circuit in either one of two wires leading from sensor probe to computer
    - (1) Connection at sensor bracket assembly connector
    - (2) Connection at computer harness connector
  - c. Faulty coin controller (computer)
  
- 14. Dryer does not respond to command at keyboard.
  - a. Faulty keyboard label assembly
  - b. Faulty coin controller (computer)
  
- 15. Dryer does not start. Display reads "door."
  - a. D.C. door switch (lower switch) is out of adjustment or is defective.
  - b. Open circuit in either one of the two gray wires leading from the door switch to the computer.
  
- 16. Computer does not accept coin entries.
  - a. Check amount to start (AtSt) program to assure that setting is correct.

- b. Faulty coin acceptor optical switch.
  - c. Open circuit in any one of the wires from acceptor optic switch to computer.
17. Computer accepts coin and temperature selection entries, but display reads temperature selected and 00. (i.e. HI00).
- a. Incorrect program setting. Computer is set in "automatic" mode.

## SECTION VIII

### Servicing

Introduction: All electrical/mechanical service or repairs should be made with the electrical power to the dryer disconnected (power off).

WARNING: Personal injury could result.

The information provided in this section should not be misconstrued as a device for use by an untrained person making repairs. Only properly licensed technicians should service the equipment.

When contacting the factory for assistance, always have the dryer model and serial numbers available.

CAUTION: Observe all safety precautions displayed on the dryer or specified in this manual before and while making repairs.

### TABLE OF CONTENTS

A.	<u>Computer Controls</u> .....	117
	Computer Control Panel Assembly.....	117
	Computer.....	117
	Coin Acceptor.....	118
	Keyboard Label Assembly.....	118
	Temperature Sensor Probe.....	118
	A.S. Board and P.C.B. relays.....	119
B.	<u>Mechanical Coin Meter Controls (non-computer)</u> ...	120
	Indicator Light.....	120
	Heat Selector Rocker Switch.....	120
	Push to Start Relay.....	120
	Coin Meter.....	120
C.	<u>Ignition Components</u> .....	121
	Glo-bar.....	121
	IR Sensor.....	121
	Gas Valve.....	121
	Burner Orifices.....	122
	Test and Adjust Gas Pressure.....	122
	Conversion from Natural to L.P. Gas.....	125
D.	<u>Thermostats</u> .....	127
	Burner Hi-limit Thermostat.....	127

Lint Compartment Hi-Heat Protector Thermostat...	128
Temperature Control Thermostats (non-computer models).....	128
E. Sail Switch Assembly.....	129
F. Main Door Switch.....	131
G. Main Door Assembly.....	131
H. Main Door Glass and Gasket.....	131
I. Front Panel Assembly.....	132
J. Main Door Hinge Pad.....	133
K. Tumbler Assembly.....	133
Tumbler Alignment (vertical).....	133
Tumbler Alignment (lateral).....	134
Tumbler or Tumbler Support Replacement.....	135
L. Bearings.....	136
M. V-Belts.....	137
N. Pulleys.....	139
Tumbler Pulley.....	139
Idler Pulley.....	139
Motor Pulley.....	140
O. Motor Mount Assembly.....	140
Motor.....	141
Impellor (fan).....	141
P. Lint Screen.....	141

## A. Computer Controls

### To Replace Computer Control Panel Assembly

1. Discontinue power to dryer.
2. Disconnect main power harness from rear of computer by squeezing locking tabs and pulling connector straight back.
3. Disconnect the ground (green) wire from the computer.
4. Disconnect the wires (2) from the HI and HO terminals of the computer.
5. Disconnect the wiring from the coin acceptor optic switches(es).
6. To remove control panel assembly from control box, gently tap the bottom on the control panel and lift off of hinges.
7. Install new control panel assembly by reversing this procedure.

NOTE: For dual coin acceptor dryers, when reconnecting the optic switch harnesses, be sure that the harness connector with the red, green, and orange wires is connected to the higher denomination acceptor (i.e., 25¢).

### To Replace Computer

1. Discontinue power to dryer.
2. Disconnect main power harness from rear of computer by squeezing locking tabs and pulling connector straight back.
3. Disconnect the ground (green) wire from the computer.
4. Disconnect the wires (2) from the HI and HO terminals of the computer.
5. Disconnect keyboard ribbon from computer.
6. Remove the four (4) hex nuts securing the computer to the sheet metal control panel and disassemble computer from panel.
7. Install new computer by reversing this procedure.

### To Replace Coin Acceptor

1. Disconnect power to dryer.
2. Disconnect optical switch harness connector(s) from coin acceptor.
3. Loosen slotted head screw securing retainer clip in place, slide retainer clip downward, and remove acceptor from the face side of the control panel assembly.
4. Install new acceptor by reversing procedure.

### To Replace Keyboard Label Assembly

1. Discontinue power to dryer.
2. Unplug keyboard ribbon from rear of computer.
3. Slowly peel off and remove keyboard label assembly from control panel.
4. Peel paper backing off of new keyboard label assembly.
5. Holding the new keyboard label assembly close to the control panel, insert the keyboard ribbon through the rectangular slot in the control panel. Align label assembly into position and gently press into place.
6. Connect keyboard ribbon to computer.
7. Reestablish power to dryer.

### To Replace Temperature Sensor Probe

1. Discontinue power to dryer.
2. Remove M.P. Sensor bracket assembly from dryer.
  - a. Disconnect sensor bracket harness connector.
  - b. Loosen the two (2) phillips head screws securing bracket assembly to dryer and remove bracket from dryer.
3. Disassemble sensor probe from bracket assembly by removing the top push-on fastener securing the probe to the bracket.
4. Disconnect the two (2) orange wires from the high heat (225°) temperature sensor, remove modular bracket connector, wires, and probe from bracket assembly.



5. Install new sensor probe assembly (P/N 880251) by reversing procedure.
6. Reestablish power to dryer.

NOTE: If, when power is reestablished, the computer display reads "dSFL", check for a loose connection in the wiring. If connections appear to be okay, reverse polarity of the sensor probe by reversing the wires at the sensor bracket connector holes number 1 and 2.

#### To Replace A.S. Board and P.C.B. Heat and/or Motor Relays

1. Discontinue power to dryer.
2. Locate and remove all wires from the arc suppressor (A.S.) boards terminals and relays.

NOTE: Identify location of each wire for correct reinstallation.

3. Remove A.S. board assembly from control box wall by pressing in the locking tabs of the nylon standoffs at each corner of the board.

NOTE: If an entire new board is to be used, skip steps 4 through 5.

4. To replace individual printed circuit board (P.C.B.) relays, locate the three (3) solder points securing the relay to the back side of the A.S. board. Using a soldering iron, remove the solder at each of these points and disassemble relay from board.

IMPORTANT: Avoid damaging board printed circuits.

5. Assemble new relay onto A.S. board. Press and hold firmly in place and apply a small amount of solder to each of the three (3) relay pins.

NOTE: The solder points are not only used to secure the relay to the board, they are also important electrical connections.

6. Assemble A.S. board to dryer by reversing steps 2 and 3.
7. Reestablish power to dryer.

## B. Mechanical Coin Meter Controls (non-computer)

### To Replace Indicator Light

1. Discontinue power to dryer.
2. Disconnect the two (2) wires from the indicator light at the control panel 2-position terminal strip.
3. Push and hold in the two (2) locking lances of the indicator light and pull light out through face side of control panel.
4. Install new indicator light by reversing the procedure.

### To Replace Heat Selector Switch

1. Discontinue power to dryer.
2. Disconnect wiring from heat selector switch.

IMPORTANT: Identify location of each wire for correct reinstallation.

3. Push and hold in the right top and bottom locking lances of the selector switch and push slightly forward to the right. Push and hold in left top and bottom locking lances and push switch out through face side of panel.
4. Install new heat selector switch by reversing this procedure.

### To Replace Push-to-Start Relay

1. Discontinue power to dryer.
2. Remove wiring from push-to-start relay.
3. Disassemble push-to-start relay from control panel by removing the two (2) slotted head screws securing the push-to-start relay to the panel mounting bracket.
4. Reverse this procedure for installing push-to-start relay.

### To Replace Mechanical Coin Meter

1. Discontinue power to dryer.
2. Disconnect wiring at coin meter switches.

NOTE: Identify location of each wire for correct reinstallation.

3. Locate and remove the two (2) slotted head screws securing the push-to-start relay in place. Do not disconnect wiring. Move push-to-start relay aside, so coin meter can be disassembled from panel with ease.
4. To disassemble coin meter from control panel, locate and remove the two (2) Hex nuts securing meter to panel.
5. Reverse this procedure for installing coin meter.

C. Ignition Components

To Replace Glo-bar

1. Discontinue power to dryer.
2. Disconnect glo-bar power harness connector.
3. Disassemble glo-bar from mounting bracket by removing machine screw, washer, and nut.

NOTE: If adjustment of glo-bar closer to burner tube is needed, bend mounting bracket upward. To avoid damaging glo-bar, do not make adjustments while glo-bar is mounted to bracket.

4. Reverse procedure for installing new glo-bar.

IMPORTANT: Before reestablishing power to dryer, visually check glo-bar to assure it is not touching tube burner.

To Replace IR Sensor (flame switch)

1. Discontinue power to dryer.
2. Disconnect wiring to IR Sensor.
3. Disassemble IR sensor from mounting bracket by removing machine screw, washer, and nut.
4. Reverse procedure for installing new IR sensor.

To Replace Gas Valve

1. Discontinue power to dryer.
2. Close shut-off valve(s) in gas supply line.

3. Disconnect gas valve wiring.

NOTE: Identify location of each wire for correct reinstallation.

4. Break union connection at gas valve shut-off body.
5. Loosen and remove screws (2) securing gas valve mounting bracket to burner.
6. Remove gas valve/manifold assembly from dryer.
7. Remove valve mounting bracket, manifold, and union collar tail piece from gas valve.

NOTE: To remove union collar tail piece, a 1/2-inch Allen wrench is needed.

8. Reverse procedure for installing new gas valve.

WARNING: Test all connections for leaks by brushing on a soapy water solution. NEVER TEST FOR LEAKS WITH A FLAME.

#### To Replace Main Burner Orifices

1. Refer to "Replace Gas Valve" and follow steps one through six.
2. Unscrew main burner orifices and replace.

NOTE: Use extreme care when removing and replacing orifices. These orifices are made of brass and are easily damaged.

3. Reverse the removal procedure for re-installing.

WARNING: Test all connections for leaks by brushing on a soapy water solution. NEVER TEST FOR LEAKS WITH A FLAME.

#### To Test and Adjust Gas (water column) Pressure

There are two (2) types of devices commonly used to measure water column pressure. They are spring/mechanical type gauges and manometers. The spring/mechanical type gauge is not recommended, because it is easily damaged and is not always accurate. A manometer is simply a glass or transparent plastic tube with a scale in inches, which, when filled with water and pressure is applied, the water in the tube rises, showing the exact water column pressure.

NOTE: Manometers are available from the factory by ordering part number 122804.

1. To Test Gas Water Column (W.C.) pressure:
  - a. Connect water column test guage connection to gas valve pressure tap (1/8" N.P.T.)
  - b. Start dryer. With burner on, the correct water column reading in inches should be:

Natural Gas - 4 Inches W.C.  
L.P. Gas - 11 Inches W.C.

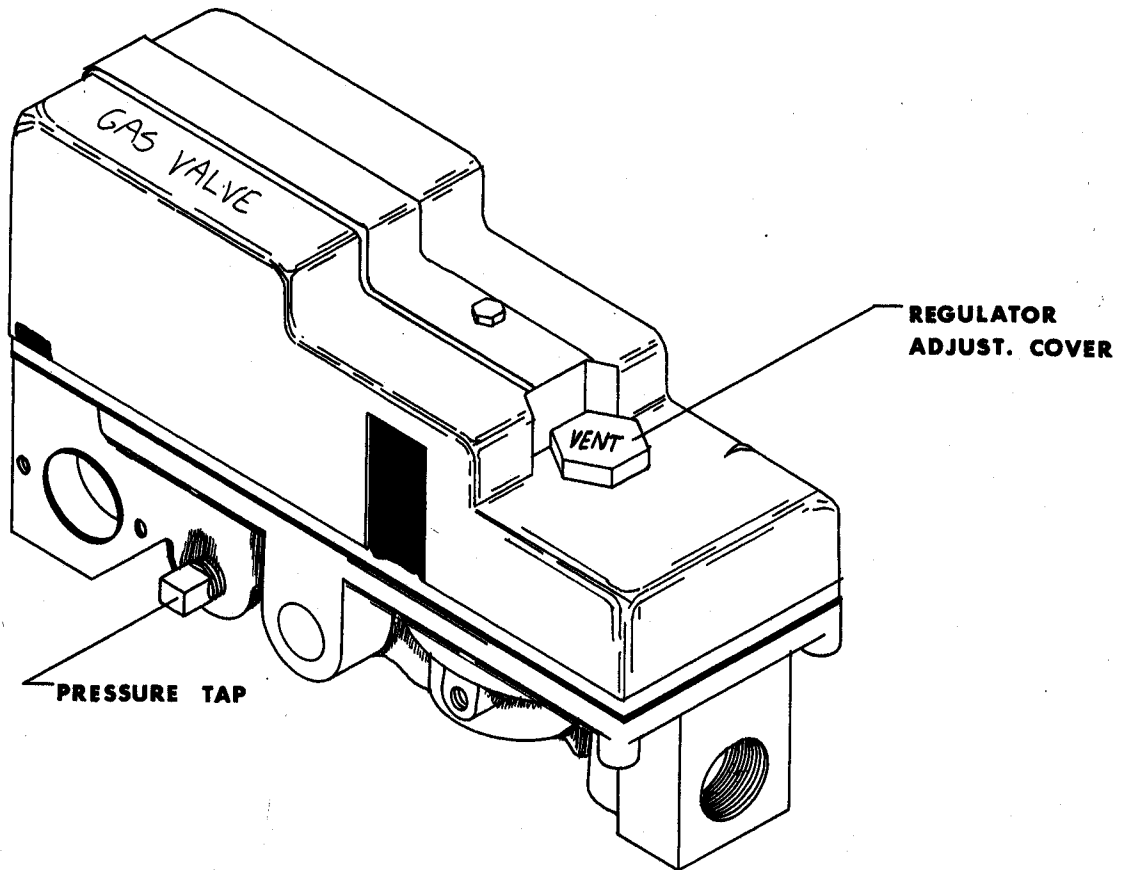

2. To adjust water column pressure (natural gas only):
  - a. Remove regulator adjustment cover.
  - b. Turn the slotted head adjustment screw, located in

the gas valve well--clockwise to increase manifold gas pressure and counter clockwise to decrease pressure.

c. Replace regulator adjustment cover.

NOTE: If correct, W.C. pressure cannot be achieved, problem may be due to an undersized gas supply line, a faulty or underrated gas meter, etc.

3. To adjust water column pressure (L.P. Gas only):

Dryers manufactured for use with L.P. gas have no pressure regulator or means of regulation built into the dryer. Regulation must be provided at the gas supply (L.P. tank). If regulation adjustment is necessary, contact L.P. gas supplier.

NOTE: If correct or consistent W.C. pressure cannot be achieved, problem may be due to an undersized gas supply line or a faulty regulator.

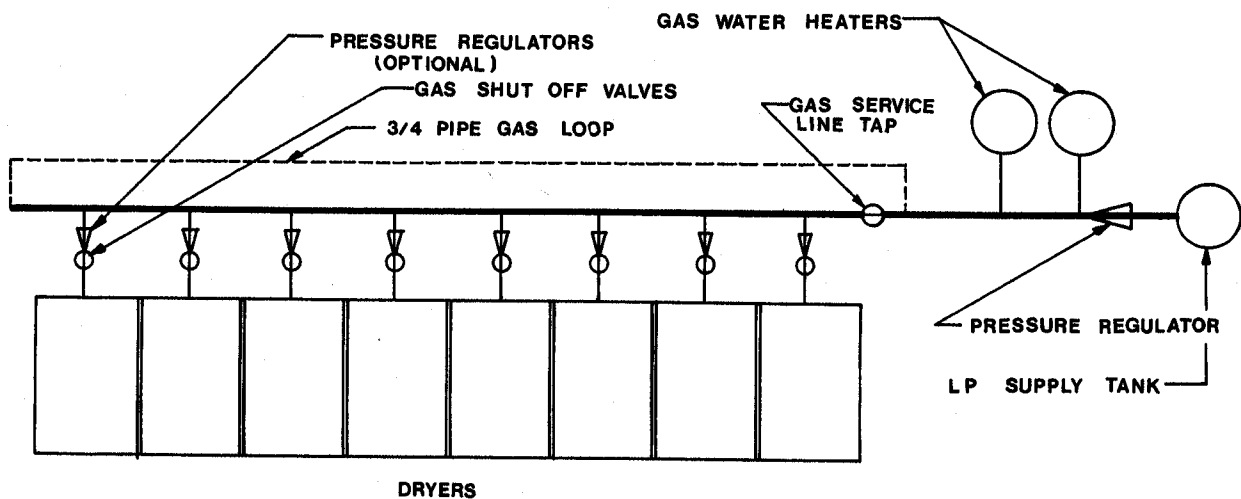

TYPICAL L.P. GAS INSTALLATION

## To Convert from Natural to L.P. Gas

Parts required for conversion:

Non-computer models - L.P. Kit, P/N 874010\*  
Hi/Lo Computer Models - L.P. Kit, P/N 874011\*

\*For butane gas or elevations over 2,000 feet, contact factory.

### 1. Non-Hi/Lo Models

- a. Disconnect power to dryer.
- b. Close shut-off valves in gas supply line.
- c. Disconnect gas valve wiring.

NOTE: Identify location at each wire for reinstallation.

- d. Break union connection at gas valve shut-off valve body.
- e. Loosen and remove screws (2) securing gas valve mounting bracket to burner.
- f. Remove gas valve/manifold assembly from dryer.
- g. Unscrew main burner orifices and replace with L.P. orifices.

NOTE: Use extreme care when removing and replacing orifices. These orifices are made of brass and are easily damaged.

- h. Locate and remove gas valve regulator adjustment (vent) cover. Replace with L.P. stem cover and washer supplied in L.P. kit.

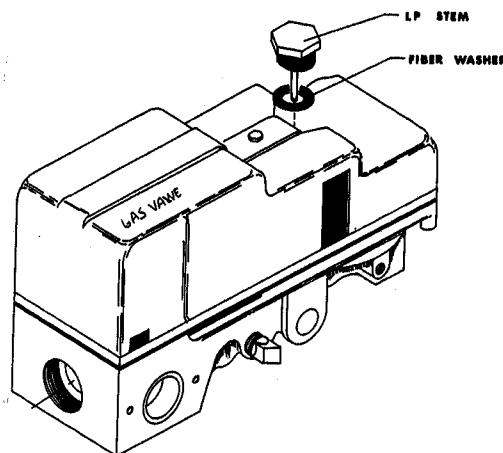

- i. Reverse the procedure for reinstalling valve assembly to dryer.

IMPORTANT: External regulation of a consistent 11 inches water column pressure must now be provided.

## 2. Computerized Hi/Lo Gas Valve Models

- a. Discontinue power to dryer.
- b. Close shut-off valves in supply line.
- c. Disconnect gas valve wiring.

NOTE: Identify location of each wire for correct re-installation.

- d. Break union connection at gas valve shut-off body.
- e. Loosen and remove screws (2) securing gas valve mounting bracket to burner.
- f. Remove gas valve/manifold assembly from dryer.
- g. Unscrew main burner orifices and replace with L.P. orifices.

NOTE: Use extreme care when removing and replacing orifices. These orifices are made of brass and are easily damaged.

- h. Locate and remove gas valve regulator adjustment (vent) cover. Replace with L.P. stem cover and washer supplied in L.P. kit. See illustration.
- i. Remove manifold from gas valve (outlet port).
- j. Locate small orifice inside outlet port of gas valve and remove with a 11/32 nut driver. Replace with orifice supplied in L.P. kit.
- k. Reverse procedure for reinstalling valve assembly to dryer.

IMPORTANT: EXTERNAL REGULATION of a consistent 11 inches water column pressure must now be provided.

NOTE: W.C. pressure reading of 11 inches is when burner is in high-fire.



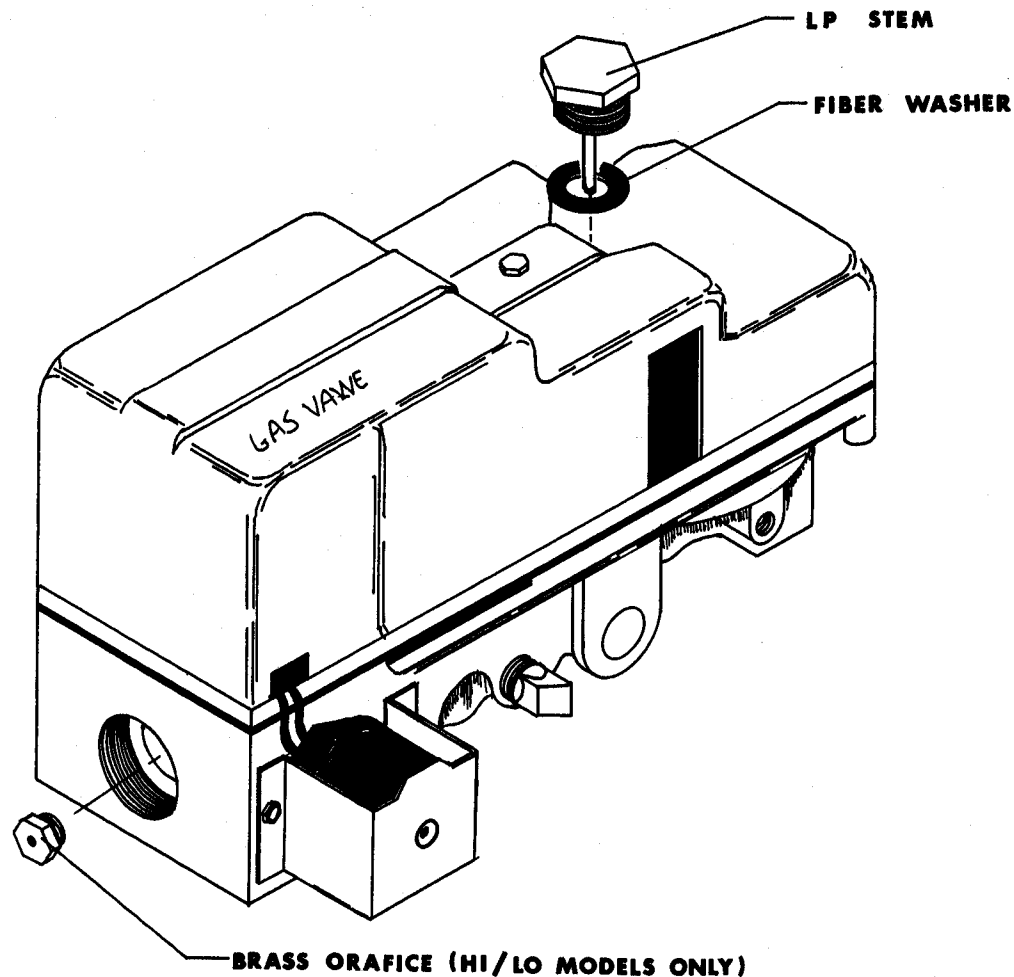

#### D. Thermostats

##### Burner Hi-Limit (330°) Thermostat

This thermostat is located on the left side of the burner, and is an important safety device serving as an added protection against failure of the air sail switch to open in the event of motor failure or reduced draft condition.

**IMPORTANT:** Under no circumstances should heat circuit safety devices ever be disabled.

##### To Replace

1. Discontinue power to dryer.
2. Remove lower and middle back guard sections at rear of dryer.
3. Remove the two (2) screws securing the hi-limit bracket to the burner box, and slide assembly out from between burner box and dryer side panel.

4. Disconnect wires from hi-limit thermostat.
5. Disassemble hi-limit thermostat by removing the two (2) mounting screws and nuts.
6. Reverse this procedure for installing hi-limit thermostat.

#### Lint Compartment Hi-Heat Protector (225°) Thermostat

This thermostat is part of the "sensor bracket assembly" and is secured to the underside of the tumbler wrapper in the lint compartment. As a safety device, this thermostat will open (shut off) the heating unit circuit if an excessive temperature occurs. The dryer motor will remain on, even if this thermostat is open.

IMPORTANT: Under no circumstance should heat safety devices ever be disabled.

#### To Replace

1. Discontinue power to dryer.
2. Open lint compartment door and locate sensor bracket assembly.
3. Loosen the two (2) phillips head screws securing the bracket assembly to the tumbler wrapper.
4. Remove bracket assembly by slightly sliding bracket towards rear of dryer and to the right.
5. Disconnect sensor bracket harness connector and remove bracket assembly from dryer.
6. Disconnect the two (2) orange wires from the thermostat.
7. Disassemble thermostat from bracket assembly by removing the two (2) mounting screws, washers, and nuts.
8. Reverse this procedure for installing hi-heat protector thermostat.

#### Temperature Control Thermostats (non-computer)

These thermostats will open or close the circuit to the heating unit when their preset temperature settings are reached. The temperature control thermostats are part of the "sensor bracket assembly" secured to the underside of the tumbler wrapper in the lint compartment.

#### To Replace

1. Discontinue power to dryer.

2. Open lint compartment door and locate sensor bracket assembly.
3. Loosen the two (2) phillips head screws securing bracket assembly to tumbler wrapper.

NOTE: Do not remove screws.

4. Remove bracket assembly by slightly sliding bracket towards rear of dryer and to the right.
5. Disconnect sensor bracket harness connector and remove bracket assembly from dryer.
6. Disconnect wiring to defective thermostat.
7. Disassemble defective thermostat from bracket assembly by removing the two (2) mounting screws, washers, and nuts.
8. Reverse this procedure for installing new thermostat.

#### E. Sail Switch Assembly

The sail switch is a heat circuit safety device which controls the burner circuit only. When the dryer is operating and there is proper air flow, the sail switch damper pulls in and closes the sail switch. Providing all the other heat-related circuits are functioning properly, ignition should now be established. If an improper air flow occurs, the sail switch damper will be released, and the circuit will open.

IMPORTANT: Under no circumstances should heat circuit safety devices ever be disabled.

#### To Replace

1. Discontinue power to dryer.
2. Remove lower and middle back guard sections at rear of dryer.
3. Remove the two (2) screws which hold the sail switch box cover to the sail switch box.
4. Disconnect the two (2) wires from the switch.
5. Disassemble sail switch from mounting bracket by removing the two (2) screws securing switch in place.
6. Reverse this procedure for installing new sail switch. Adjust switch as described below.

### To Adjust Sail Switch

With the back guard assembly removed and the dryer operating at a high temperature setting, pull the sail switch damper away from the burner. The sail switch should open and extinguish the burner. Let the sail switch damper return to the burner wall. The sail switch should close to restart the burner ignition cycle. If the sail switch circuit does not operate as described, bend the actuator arm of the sail switch accordingly until proper operation is achieved. To check proper "open" position of sail switch, open main door, manually depress main door switch(es), and start dryer. With the main door open and the dryer operating, the sail switch circuit should be open, and the burner should not come on.

**CAUTION:** Do not adjust this switch by taping or screwing sail switch damper to burner. Personal injury or fire could result.

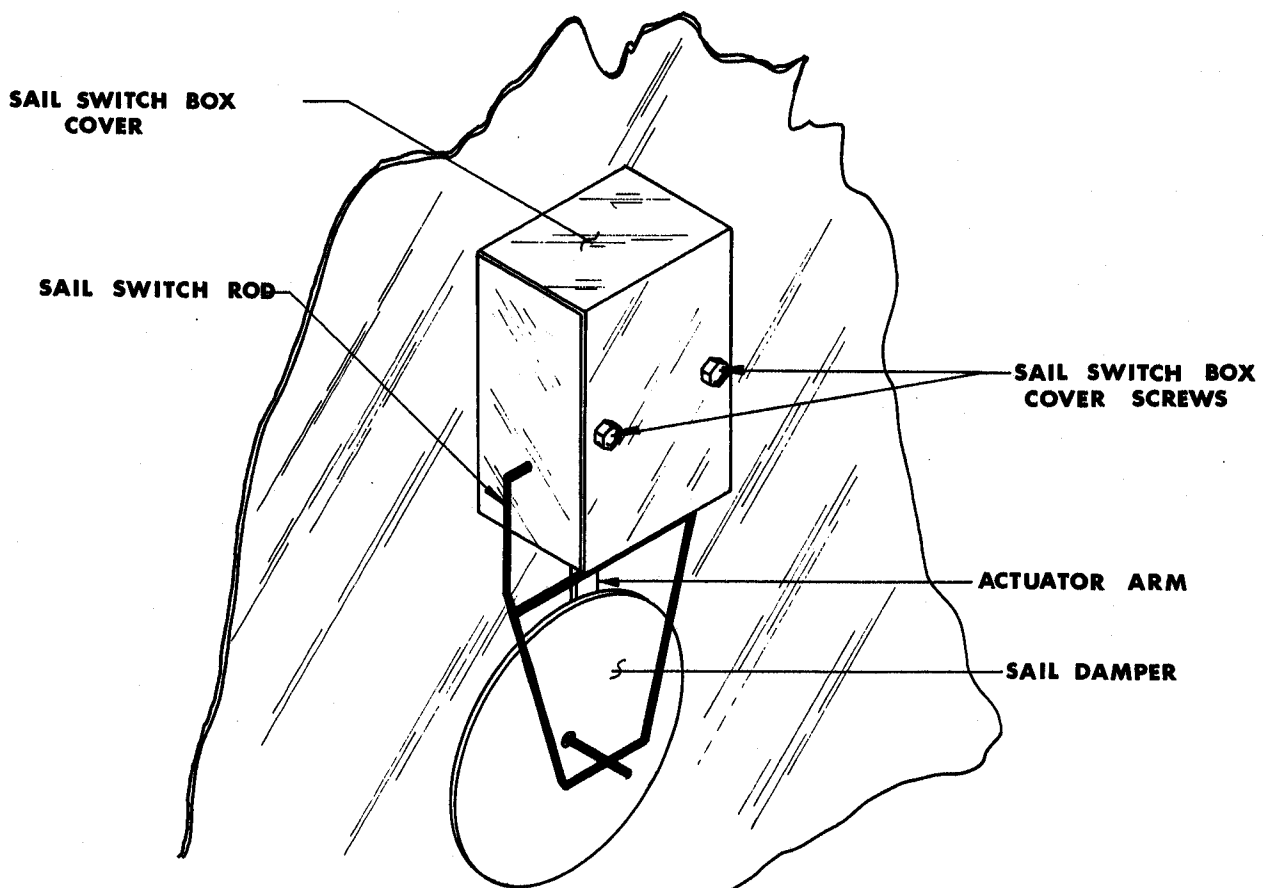

F. To Replace Main Door Switch

1. Discontinue power to dryer.
2. Open main door.
3. Remove the two (2) phillips head screws holding main door switch bracket assembly in place.
4. Remove door switch bracket from hinge block and disconnect wiring from switch.
5. Disassemble door switch from switch bracket by removing locking adjustment nut. Remove second locking nut and assemble on to new door switch.
6. Reverse this procedure for installing new door switch.

NOTE: When reconnecting wires to door switch, be sure wiring sequence is correct. One wire is to be connected to the common terminal, and the other wire to the normally (norm) open terminal of the door switch.

IMPORTANT: Under no circumstances should the door switch(es) ever be disabled.

G. Main Door Assembly

The main door assembly is designed in such a manner that it can easily be disassembled from the dryer by removing the pin securing the door hinge to the front panel pad hinge.

To Remove

1. Insert a small nail or similar object into the bottom of the hinge where the pin is located. While doing so, tap the nail, so that the hinge pin is worked upward. Once the head of the pin extends approximately 1" above the hinge, hold the door in place and, with a pair of pliers, remove the pin from the hinge assembly.
2. Reverse this procedure for re-installing main door assembly.

H. To Replace Main Door Glass and Gasket

NOTE: A dull, rounded blade made of plastic or hardwood should be used to avoid scratching the glass or tearing the gasket. However, a standard straight blade screwdriver can be used, providing that the removal and installation of the gasket is done carefully.

1. Follow procedure for removal of main door assembly (G.).
2. Lay the main door assembly face down on a flat level surface.
3. Locate the zip-lock seam of the gasket and roll the inside lip of the gasket upward from the glass, starting where the ends of the gasket butt together (top). Probe the tool blade under the edge of the zip-lock seam and advance the tool all the way around the gasket.
4. Gently, push the glass through the door cutout and remove the glass and gasket from door.
5. Examine the end of the new, extruded gasket. Starting at the top of the door circle, insert the edge of the door cutout into the thin slot of the gasket. Be sure that the thick slot for the glass is toward the center open area of the door circle and that the zip-lock portion of the gasket is facing upward. Press the gasket into place around the cutout. Do not cut excess length from gasket. Work gasket around circle until ends butt neatly together.
6. Press edge of glass firmly into wide gasket slot at top and work glass into slot with tool edge inserted between the perimeter edge of the glass and gasket lip. Advance tool around gasket while pressing edge of glass into slot.
7. Work butt ends of gasket to obtain a neat, tight joint.
8. Brush or spray a soapy water solution into the entire length of the zip-lock seam. Once this is done, begin the sequence of locking the zip seam by inserting the locking lip at the zip-lock seam into the receiving slot at one of the gasket butt ends. Press into place with tool blade. With the zip-lock started, probe the tool blade into the zip-lock seam and advance until entire seam is locked into place.
9. Re-install door assembly onto dryer.

#### I. Front Panel Removal

1. Discontinue power to dryer.
2. Disconnect main door switch wiring from inside control wire box.

NOTE: Identify location of each wire for correct re-installation.

3. Follow procedure for removal of main door assembly (G.).
4. Open control (service) door and remove hex head screw located at the center of the front panel lip.
5. Remove lint door from dryer.
6. Remove the eight (8) phillips head screws (4 at each side of front panel) securing front panel to dryer.
7. Gently remove front panel assembly from dryer.

IMPORTANT: When removing front panel assembly, be careful as not to damage main door switch wires disconnected in step 2.

8. Reverse this procedure for installing front panel.

J. To Replace Main Door Hinge Pad

1. Discontinue power to dryer.
2. Follow procedure for removal of main door assembly (G.).
3. Follow procedure for removal of front panel assembly (I.).
4. Disassemble hinge pad from front panel by removing the four (4) hex nuts located on the back side of the front panel.

IMPORTANT: When removing hinge pad assembly from front panel, be careful as not to damage main door switch wires.

5. Remove main door switch(es), wires, and spacer nuts from hinge pad assembly.
6. Reassemble by reversing removal procedure.

NOTE: When reconnecting wires to door switch, be sure wiring sequence is correct. One wire is to be connected to the common terminal, and the other wire to the normally (norm) open terminal of the door switch.

K. Tumbler Assembly

Tumbler Alignment (vertical)

1. Discontinue power to dryer.
2. Remove lower back guard panel section at rear of dryer.

3. Loosen the four (4) hex head bolts on the sides of the bearing box (2 each side).
4. Back off jam nuts on allen head adjustment screws.
5. Turn the screws clockwise evenly to raise tumbler or counter-clockwise evenly to lower tumbler.
6. Rotate tumbler from front and check alignment with main door opening.
7. Leave a large gap from the inside ring on the top of the front panel opening to the tumbler (basket), and a smaller gap on the bottom to compensate for the weight of the clothes when drying.
8. Tighten the four (4) hex head bolts on the sides of the bearing box, and the jam nuts on the two (2) allen head adjustment screws.
9. Check tumbler drive belt for proper tension. Adjust if required.
10. Replace back guard panel and reestablish power to dryer.

#### Tumbler Alignment (lateral)

1. Discontinue power to dryer.
2. Remove lower back guard panel section at rear of dryer.
3. Loosen the two (2) hex head bolts (1/2 to 1 turn), holding the pillow block bearing to the bearing box.
4. Back off the jam nuts on the side adjustment bolts.

NOTE: Rotate tumbler from front and check alignment with main door opening. The spacing between the tumbler (basket) and the inside rim of the front panel should be equal.

5. Lateral adjustment (See illustration on following page)
  - a. To increase gap R, loosen (turn counter-clockwise) adjustment bolt A and tighten (turn clockwise) adjustment bolt B.
  - b. To decrease gap R, loosen (turn counter-clockwise) adjustment bolt B and tighten (turn clockwise) adjustment bolt A.
  - c. To increase gap L, loosen (turn counter-clockwise) adjustment bolt B and tighten (turn clockwise) adjustment bolt A.



- d. To decrease gap L, loosen (turn counter-clockwise) adjustment bolt A and tighten (turn clockwise) adjustment bolt B.

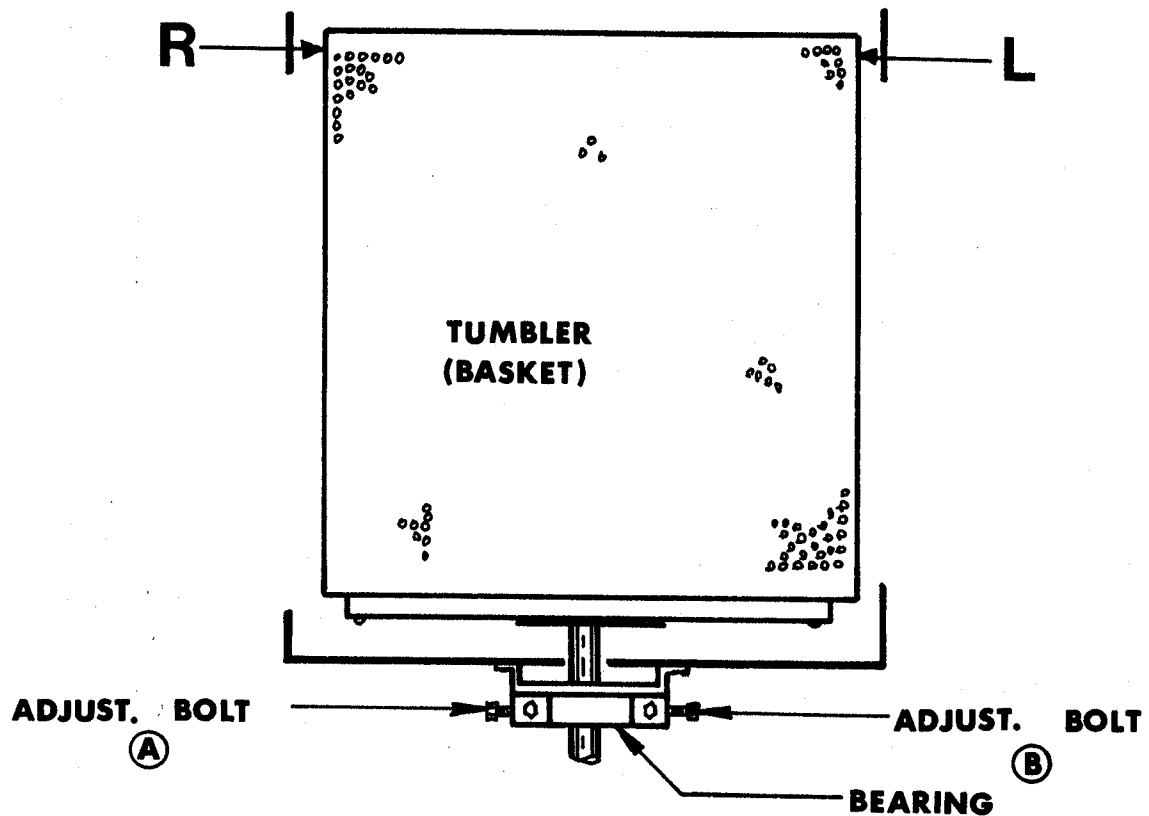

## Rear View

6. Tighten and secure both adjustment bolts and jam nuts.
7. Tighten bearing box bolts loosened in step 3.
8. Replace back guard panel and re-establish power to dryer.

### To Replace Tumbler or Tumbler Support

1. Discontinue power to dryer.
2. Follow procedure for removal of main door assembly (G.).
3. Follow procedure for removal of front panel assembly (I.).
4. Remove lower back guard section at rear of dryer.
5. Remove tumbler (18") pulley.

- a. Rotate pulley and roll V-belt out of groove.
  - b. Remove hex head bolt and washers from back of pulley.
  - c. Loosen pulley set screws (2).
  - d. Remove pulley and key.
6. Remove tumbler assembly and tumbler support.
    - a. Loosen the two (2) set screws on both the pillow block bearing and the flange bearing. The two (2) set screws on the flange bearing can be reached through the opening on bottom of bearing box.
  7. Remove tumbler and support assembly from the front of the dryer. If the tumbler cannot be removed freely, clean the shaft area and spray with WD-40 or similar lubricant. With a block of wood against the shaft end, strike the block of wood with a hammer or mallet to move shaft past burrs made by set screws.

IMPORTANT: NEVER STRIKE THE SHAFT DIRECTLY WITH A HAMMER.

8. Remove tumbler from tumbler support.
  - a. Remove socket set screw in center of tumbler back wall.
  - b. Loosen and remove the three (3) sets of nuts and washers from tumbler tie rods. Remove tie rods (3).
  - c. Replace either tumbler or tumbler support by reversing procedure.
9. Reassemble components onto dryer by reversing steps 2 through 7.
10. Check tumbler vertical/lateral alignment and adjust as found necessary.
11. Replace back guard panel and reestablish power to dryer.

#### L. Bearings

Bearings are sealed and need no lubrication.

##### To Replace Rear Pillow Block Bearing

1. Discontinue power to dryer.
2. Remove lower back guard panel section at rear of dryer.

3. Remove tumbler (18") pulley.
  - a. Rotate pulley and roll V-belt out of groove.
  - b. Remove hex head bolt and washers from back of pulley.
  - c. Loosen pulley set screws (2).
  - d. Remove pulley and key.
4. Loosen adjustment jam nuts and bolts (one each side of bearing box).
5. Loosen set screws (2) from bearing.
6. Remove the two (2) sets of nuts, washers, and bolts, securing bearing to bearing box. Remove bearing.
7. Replace by reversing steps 3 through 6.
8. Adjust both lateral and vertical tumbler alignment.
9. Replace back guard panel and reestablish power to dryer.

#### To Replace Front 1-3/8" Flange Bearing

1. Discontinue power to dryer.
2. Follow steps 2 through 6 from "Replacement of Rear Pillow Block Bearing."
3. Remove the four (4) sets of nuts, washers, and bolts, securing bearing housing to dryer. Remove bearing box housing.
4. Remove the four (4) nuts holding front flange bearing to dryer.
5. Loosen bearing set screws (2) and remove bearing from dryer.
6. Replace by reversing steps 2 through 5.

NOTE: Before replacing back guard panel, check tumbler lateral/vertical adjustment, as well as belt adjustment. Correct as found necessary.

7. Reestablish power to dryer.

#### M. V-Belts

V-belts should have proper tension. If too loose, they will slip; if too tight, excessive wear on the bearings will result.

If the pulleys are not properly aligned, excessive belt wear will result.

#### To Align V-Belts

1. Discontinue power to dryer.
2. Remove lower back guard section at rear of dryer.
3. Loosen set screws (2) on idler (middle) pulley. Position the idler pulley, so that the belt from the tumbler pulley (top) rides evenly on both these two (2) pulleys. Tighten set screws.
4. Loosen motor pulley set screw. Position the motor pulley, so that the belt between the idler and motor ride evenly on the pulleys. Tighten set screw.
5. Replace back guard section.
6. Reestablish power to dryer.

#### Belt Tension Adjustment

1. Discontinue power to dryer.
2. Remove lower back guard section at rear of dryer.
3. Loosen the two (2) sets of nuts, washers, and bolts, securing idler assembly to dryer.
4. Locate adjustment bolt and loosen jam nut(s).
5. Loosen/tighten adjustment bolt to relax/increase belt tension.
6. Tighten adjustment bolt jam nut(s).
7. Tighten hardware loosened in step 3.
8. Replace back guard section and reestablish power to dryer.

#### To Replace V-Belts

##### Tumbler Pulley to Idler (top belt)

1. Discontinue power to dryer.
2. Remove lower back guard section at rear of dryer.
3. Rotate drum pulley and roll V-belt out of groove.

4. Reverse procedure for installing V-belt.
5. Replace back guard section and reestablish power to dryer.

#### Motor Pulley to Idler (lower belt)

1. Discontinue power to dryer.
2. Remove lower back guard section at rear of dryer.
3. Remove tumbler pulley to idler V-belt by rotating drum pulley and rolling V-belt out of groove.
4. Remove motor pulley to idler pulley V-belt by rotating idler pulley and rolling V-belt out of groove.
5. Reverse procedure for installing belts.
6. Check belt alignment and adjustment and correct as described in this section.
7. Replace back guard section and reestablish power to dryer.

#### N. Pulleys

##### To Replace Tumbler (18") Pulley

1. Discontinue power to dryer.
2. Remove lower back guard section of rear of dryer.
3. Rotate pulley and roll V-belt out of groove.
4. Remove hex head bolt and washers from back of pulley.
5. Loosen set screws (2) in pulley hub.
6. Remove pulley and key.
7. Replace by reversing removal procedure.

##### To Replace Idler Pulley

1. Discontinue power to dryer.
2. Remove lower back guard section at rear of dryer.
3. Rotate drum pulley and roll V-belt out of groove.
4. Remove motor pulley to idler V-belt by rotating idler pulley and rolling V-belt out of groove.

5. Loosen idler pulley set screws (2).
6. Remove idler pulley and key from shaft.
7. Replace by reversing steps 3 through 6.
8. Check belt alignment and adjustment and correct as described in this section (M.).
9. Replace back guard section and reestablish power to dryer.

#### To Replace Motor Pulley

1. Discontinue power to dryer.
2. Remove lower back guard section at rear of dryer.
3. Remove motor pulley to idler V-belt by rotating idler pulley and rolling V-belt out of groove.
4. Loosen motor pulley set screw and remove pulley from shaft.
5. Replace pulley by reversing steps 3 and 4.
6. Check belt alignment/adjustment and correct as described in this section (M.).
7. Replace back guard section and reestablish power to dryer.

### 0. Motor Mount Assembly

#### To Replace Motor Mount Assembly

1. Discontinue power to dryer.
2. Remove lower back guard section at rear of dryer.
3. Remove motor pulley to idler V-belt by rotating idler pulley and rolling V-belt out of groove.
4. Disconnect wiring harness from motor.
  - a. Remove motor service cover/plate.
  - b. Disconnect external power leads (2 or 3) connected to internal motor terminals/wiring.
  - c. Loosen screw in BX connector and remove wiring harness from motor.
5. Remove the four (4) nuts holding motor mount to dryer and

remove motor mount assembly.

6. Replace by reversing steps 3 through 5.
7. Check belt alignment/adjustment and correct as described in this section (M.).
8. Replace back guard section and reestablish power to dryer.

#### To Replace Motor

1. Follow steps 1 through 5 from "Replacement of Motor Mount Assembly."
2. Remove the two (2) jam nuts on motor shaft (left-hand thread, turn clockwise) and work impellor and key free from motor shaft.
3. Loosen set screw on motor pulley and remove pulley from shaft.
4. Remove the four (4) hex bolts holding motor to mount and remove motor.
5. Remove BX connector from old motor and install it on the new motor.
6. Reassemble by reversing removal procedure.
7. Check belt alignment/adjustment and correct as described in this section (M.).
8. Replace back guard section and reestablish power to dryer.

#### To Replace Impellor (fan)

1. Follow steps 1 through 5 from "Replacement of Motor Mount Assembly."
2. Remove the two (2) jam nuts on motor shaft (left-hand thread, turn clockwise) and work impellor and key free from motor shaft.
3. Reassemble by reversing removal procedure.
4. Replace back guard section and reestablish power to dryer.

#### P. To Replace Lint Screen

1. Open and remove lint door from dryer.

2. Remove the two (2) hex head screws securing lint screen hold-down in place and remove hold-down from lint trap.
3. Slide lint screen out from lint trap retainers.
4. Reverse procedure for installing lint screen.



SECTION IX

Technical Data

Dryer Specifications..... 144  
Dryer Enclosure Requirements..... 145  
Exhaust Requirements..... 146  
Wire Diagrams..... 149  
Motor Wiring..... 153  
Ignition Circuit Transformer Wiring..... 154

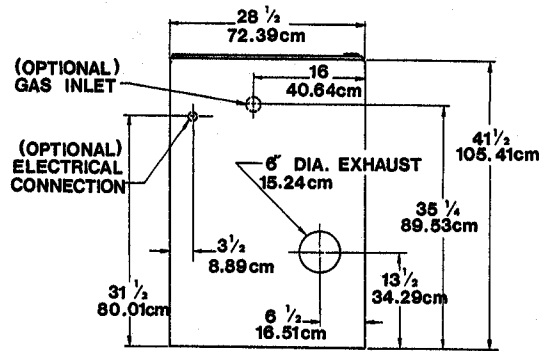

TOP VIEW

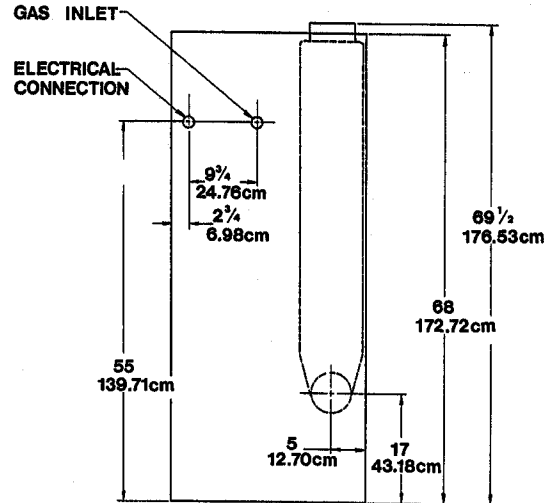

BACK VIEW

SPECIFICATIONS				
Model AD285BH				
Max. Capacity (dry weight)		30 lbs.		
Tumbler (basket) Diameter		27-1/4"		
Tumbler (basket) Depth		30"		
Door Opening		21-1/2"		
Approx. Weight (uncrated)		490 lbs.		
Approx. Shipping Weight		525 lbs.		
Motor Horsepower		1/2 H.P.		
Exhaust Duct Outlet (top)		6"		
Airflow		375 C.F.M.		
ELECTRICAL SERVICE	Voltage	Phase	No. of Wires	Amp. Draw
	115	1	2	14
	208/230	1	2	7
	208/230	3	3	5
GAS	Std. Glo-bar*		Hi/Lo	
	Gas Inlet	1/2"	1/2"	
	Heat Input	78,000	72,000	

\* Non-computer models.

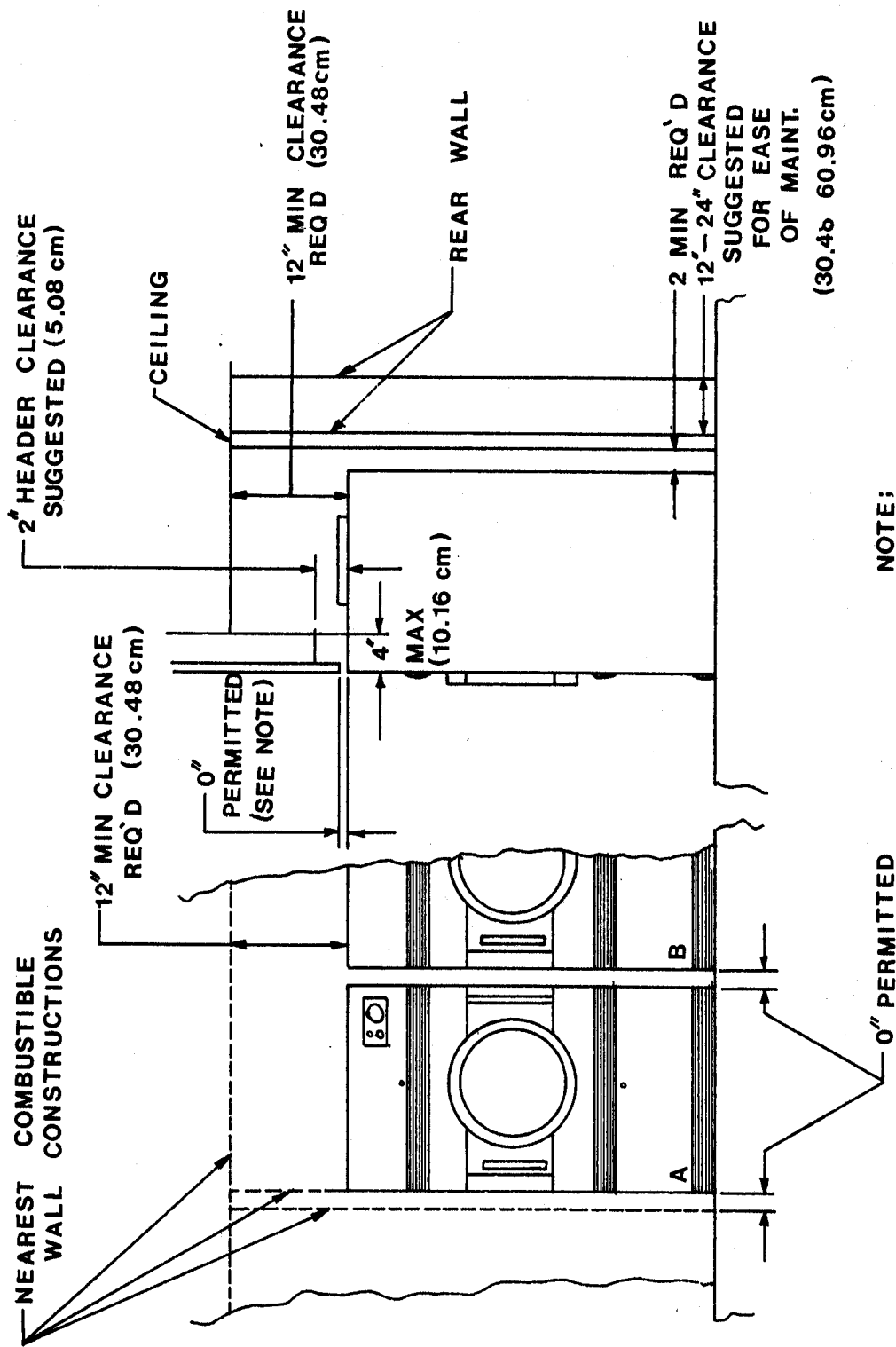

**NOTE:**

1. 0" DIMENSION PERMITTED ON HEAT RECLAIMER MODELS AFTER INSTALL.
2. EXHAUST DUCT COLLAR EXTENDS ABOVE DRYER 1-7/8.

**INSTALLATION: DRYER CLEARANCE TO ADJACENT WALL STRUCTURES**

## Exhaust Requirements

Exhaust duct work should be designed and installed by a competent technician. Improperly sized duct work will create back pressure which will result in slow drying, increased use of energy, and shutdown of the heat circuit by the airflow (sail) switch, hi-limit thermostat, or nuisance tripping of the lint chamber high heat protector.

CAUTION: Improperly sized or installed exhaust duct work can create a potential fire hazard.

Where possible, it is suggested to provide a separate exhaust duct for each dryer. The exhaust duct work should be laid out in such a way that the duct work travels as directly as possible to the outdoors with as few turns as possible. It is suggested that the use of right angle turns in the ducting be avoided; use 30° or 45° angles instead. The shape of the exhaust duct work is not critical, so long as the minimum cross section area is provided.

If the exhaust duct work is unusually long (over 20 feet) or has numerous elbows, the cross section area of the duct work must be increased in proportion to its length or the number of elbows in it. In calculating duct size, the cross section area of a square or rectangular duct must be increased 20 percent for each additional 20 feet. The diameter of a round exhaust should be increased 10 percent for each additional 20 feet. Each 90° elbow is equivalent to an additional 15 feet, and each 45° elbow, an additional 10 feet.

The duct work should be smooth inside with no projections from sheet metal screws or other obstructions which will collect lint. When adding ducts, the duct to be added should overlap the duct to which it is to be connected. Also, inspection doors should be installed at strategic points in the exhaust duct work for periodic inspection and cleaning.

To protect the outside end of horizontal duct work from the weather, a 90° elbow bent downward should be installed where the exhaust exits the building. (See illus. 1 on the following page.) If the exhaust duct work travels vertically up through the roof, it should be protected from the weather by using a 180° turn to point the opening downward. (See illus. 2 on the following page.) In either case, allow at least twice the diameter of the duct clear between the duct opening and nearest obstruction.

IMPORTANT: Do not use screens or caps on the outside opening of the exhaust duct work.

## Multiple Dryer Venting

If it is not feasible to provide separate exhaust ducts for

# MULTIPLE DRYER VENTING WITH 6" DIAMETER EXHAUST

NO. OF DRYERS	12	11	10	9	8	7	6	5	4	3	2	1
MINIMUM CROSS SECTION AREA (SQ. IN.)	540	495	450	405	360	315	270	225	180	135	90	45
MINIMUM CROSS SECTION AREA (SQ. CM.)	3485	3195	2903	2613	2323	2031	1741	1451	1161	870	580	290
MINIMUM ROUND DUCT DIAMETER (IN.)	26	25	24	23	21	20	19	17	15	13	11	8

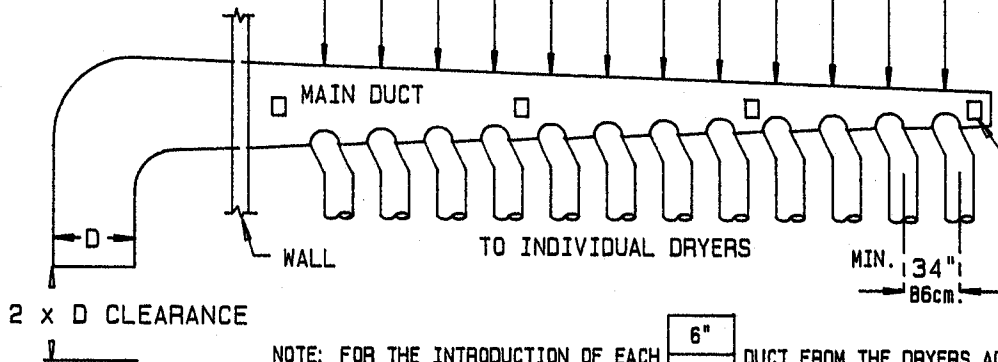

FIG. 1

NOTE: FOR THE INTRODUCTION OF EACH 6"  
152mm DUCT FROM THE DRYERS, ADD 45sq. in.  
290sq. cm. TO THE CROSS SECTIONS OF THE MAIN DUCT.

### FORMULAS TO CALCULATE DUCTING CROSS SECTIONAL AREA

CROSS SECTIONAL AREA OF A ROUND DUCT =  $.785 \times D^2$  WHERE D = DIAMETER OF THE DUCT.

CROSS SECTIONAL AREA OF A RECTANGULAR DUCT =  $W \times H$  WHERE W = WIDTH AND H = HEIGHT.

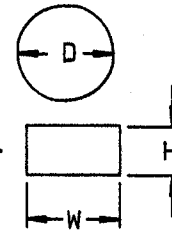
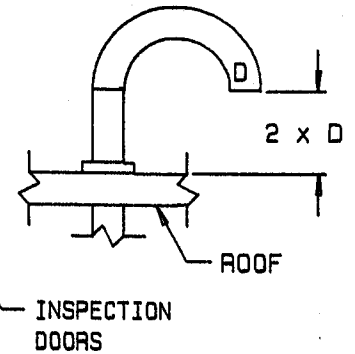
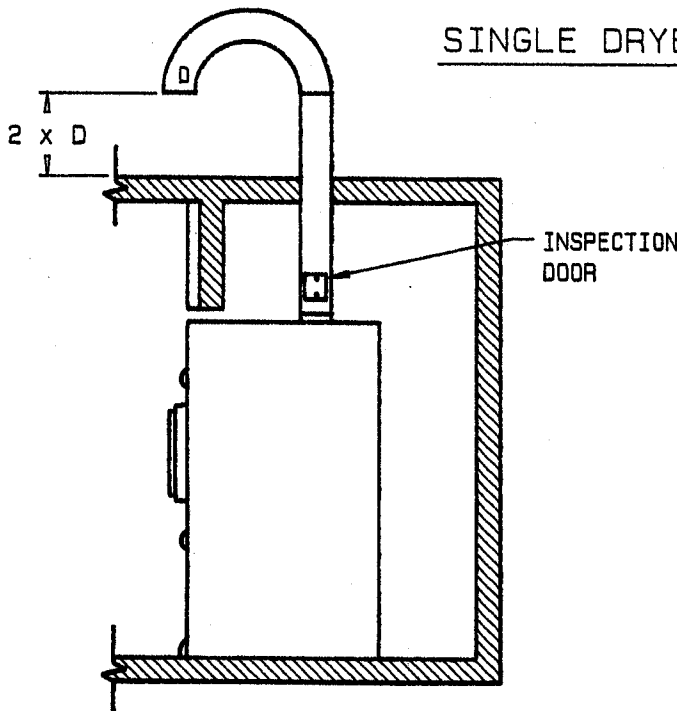

FIG. 2



## SINGLE DRYER VENTING



VERTICAL

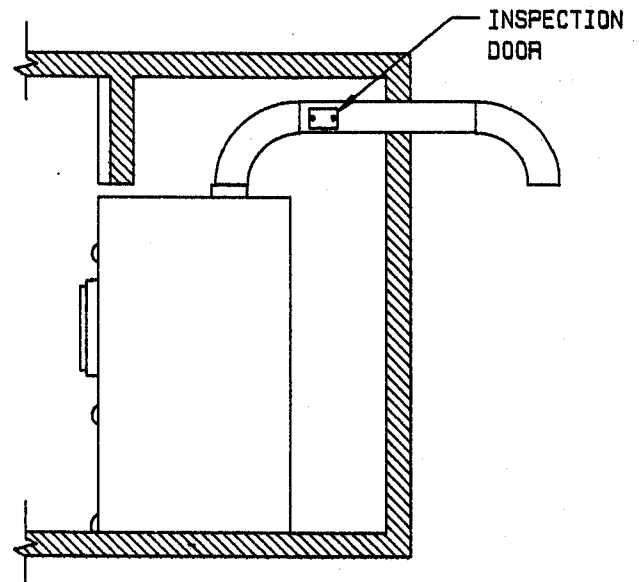

HORIZONTAL

each dryer, ducts from individual dryers may be channeled into a "common main duct". (See illus.) The individual ducts should enter the bottom or side of the main duct at an angle not more than 45° in the direction of airflow and should be spaced at least 34" apart. The main duct should be tapered, with the diameter increasing before each individual duct is added. The cross section area should be 45 square inches for each 6" duct added.

The main duct may be any shape of cross section area, so long as the minimum cross section area is provided. Illustration 1 shows the minimum cross section area for multiple dryer venting. These figures must be increased if more than 12 dryers are connected to the same main (common) duct, if the main duct end run is unusually long (20 feet or more), or if there are numerous elbows in the main duct end run. In calculating duct size, the cross section area of a square or round duct must be increased 20 percent for each additional 20 feet. The diameter of a round exhaust should be increased 10 percent for each additional 20 feet. Each 90° elbow is equivalent to an additional 15 feet, and each 45° elbow, an additional 10 feet.

It is suggested that the use of 90° turns be avoided; use 30° or 45° angles instead. The duct work should be smooth inside, with no projections from sheet metal screws or other obstructions which will collect lint. When adding ducts, the duct to be added should overlap the duct to which it is to be connected. Also, inspection doors should be installed at strategic points in the exhaust duct work for periodic inspection and cleaning.

To protect the outside end of horizontal duct work from the weather, a 90° elbow or hood turned downward should be installed where the exhaust exits the building. (See illus. 1 on preceding page.) If the exhaust duct work travels vertically up through the roof, it should be protected from the weather by using a 180° turn to point the opening downward. (See illus. 2 on the preceding page.) In either case, the cross section area of the elbow or hood must be at least the same size as the exhaust duct work outlet. Leave at least twice the diameter of the duct clear between the duct opening and nearest obstruction.

**IMPORTANT:** Do not use screens or caps on the outside opening of the exhaust duct work.

## Wiring Diagrams

A wiring diagram is located on the back side of the control (service) door of each dryer. Due to the various electrical options of the model AD285 dryer, the wire diagrams on the following pages may not necessarily depict your specific dryer. The various wire diagrams are identified by the number in the upper right-hand corner.

Computer Dryer Circuits.....	150
(115/230V, 1 Phase models)	
Computer Input/Output Circuits.....	151
Mechanical Meter Dryer Circuits.....	152

AMERICAN DRYER CORP. 394 KILBURN ST. FALL RIVER, MA.  
 GAS DRYER 100, 115, 208 or 240V 50/60 HZ

ABBREVIATIONS: C.S.-COIN SENSOR  
 M/R-MOTOR OR RELAY H.L.S.-HIGH LIMIT SWITCH  
 S.S.-SAIL SWITCH T.S.-TEMP SENSOR

531830  
 DATE: 4/1/85

REV.	DESCRIPTION	DATE	BY
1	BATTERY BACK UP ADDED	4/20/85	JW C.

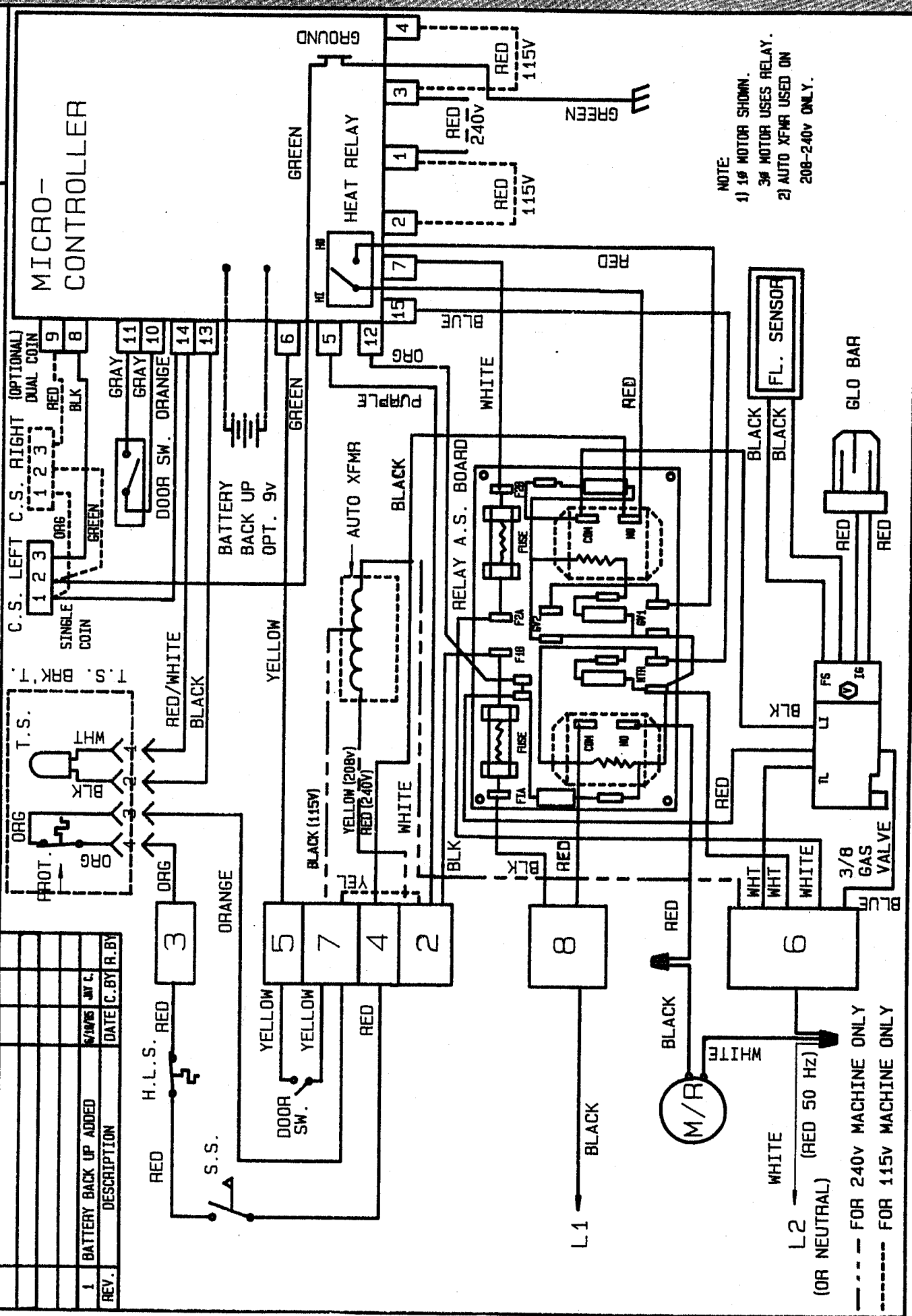

NOTE  
 1) 1Ø MOTOR SHOWN.  
 3Ø MOTOR USES RELAY.  
 2) AUTO XFMR USED ON  
 208-240V ONLY.

(OR NEUTRAL)  
 WHITE (RED 50 HZ)  
 --- FOR 240V MACHINE ONLY  
 - - - - - FOR 115V MACHINE ONLY



## Phase 3 Coin Controller Circuits

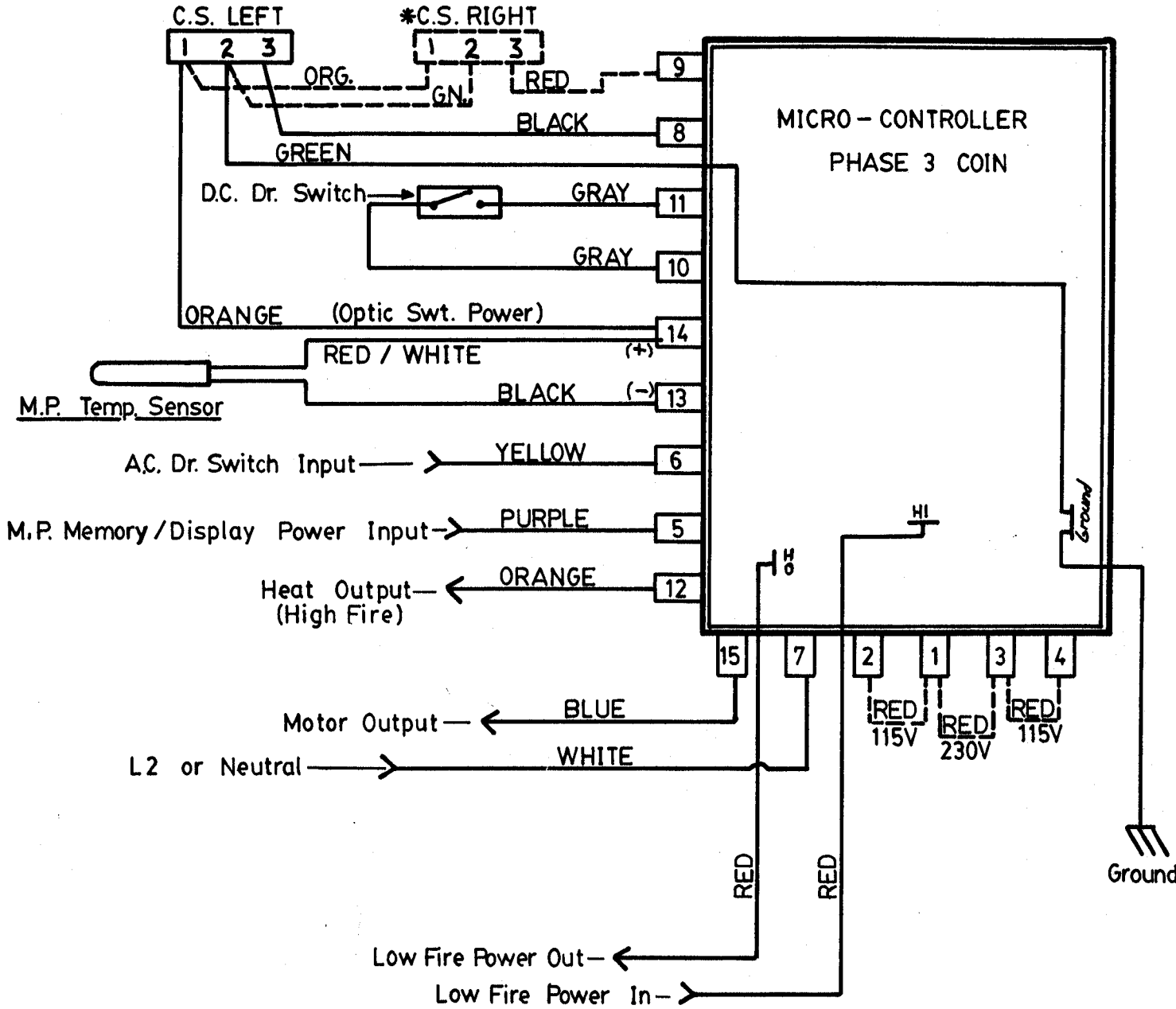

\* DUAL COIN MODELS ONLY

AMERICAN DRYER CORP.  
394 KILBURN ST., FALLRIVER, MA.

GAS DRYER 115V OR 208-240V/50/60/1 METER

C-COMMON  
HI-HIGH TEMP  
HLS-HIGH LIMIT SWITCH

LO-LOW TEMP  
M-MOTOR  
PP-PERMA PRESS

L-LINE  
SW-SWITCH  
T-THERMOSTAT

131350

DATE: 2/21/85

REV.	DESCRIPTION	DATE	C. BY	R. BY

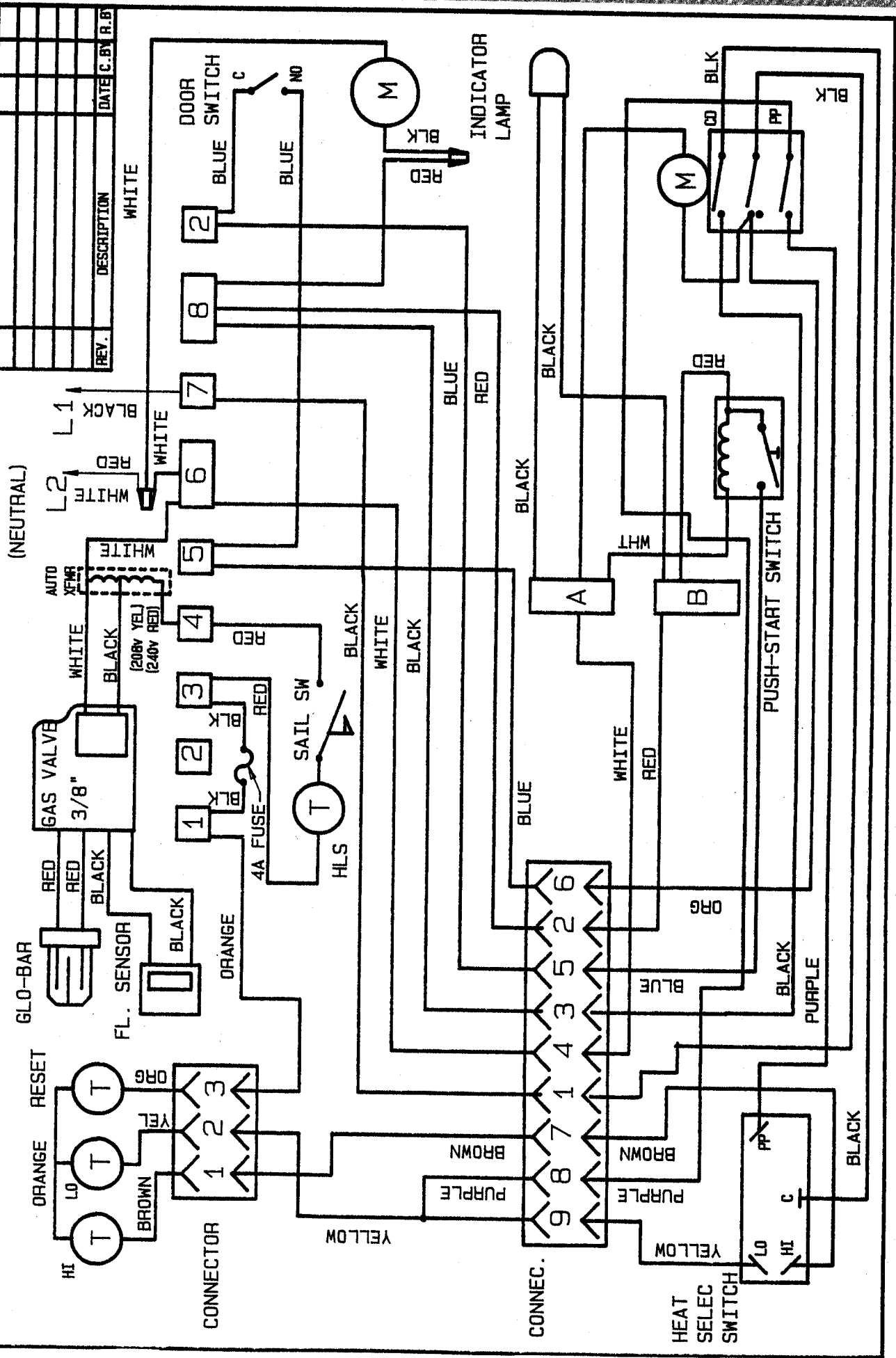

## Motor Wiring

The motor used in the American dryer is a dual voltage motor. When replacing a motor in the field, the replacement motor could have been pre-wired by the factory for operation at either 230 volts or 115 volts. Check the internal wiring of the motor to assure that the motor is wired internally for correct voltage application.

**IMPORTANT:** Motor failure due to incorrect voltage application will void warranty.

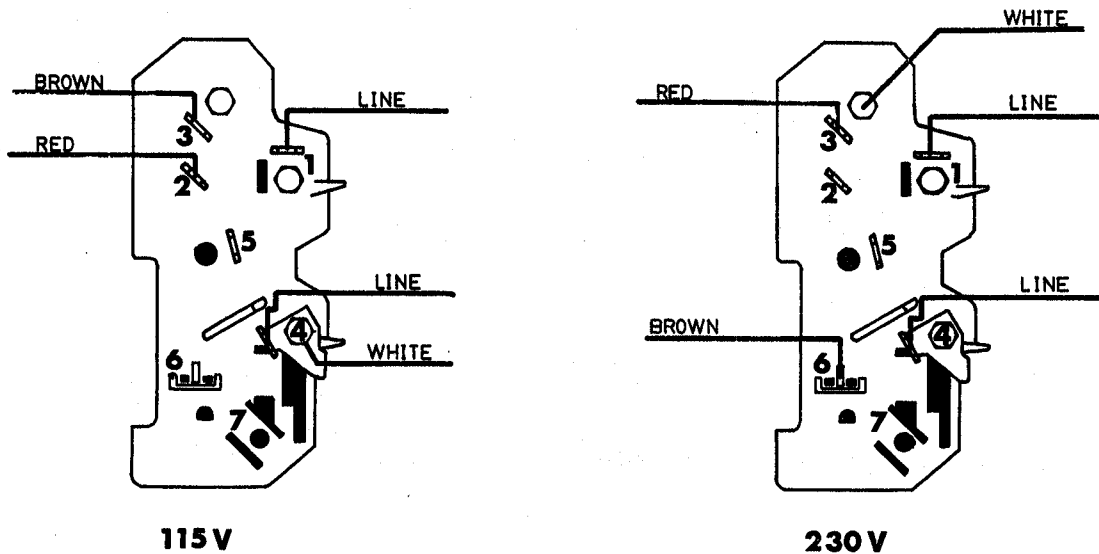

### Emerson

**1/2 HP 1Ø/60Hz  
Type; SA55 JXJ WM-5221**

P/N 100010

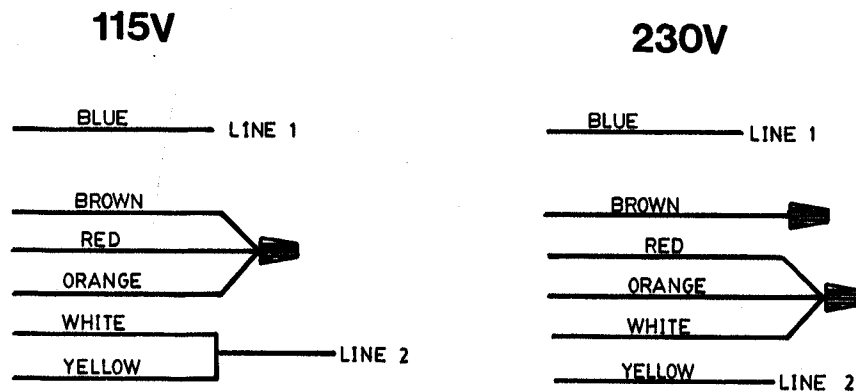

**TYPE; SA 63HYR-7015  
P/N 100004**

Ignition Circuit Transformer Wiring  
(208/230 Volt Models Only)

200 Watt Transformer

ADC P/N 132002

**208 Vac Controls**

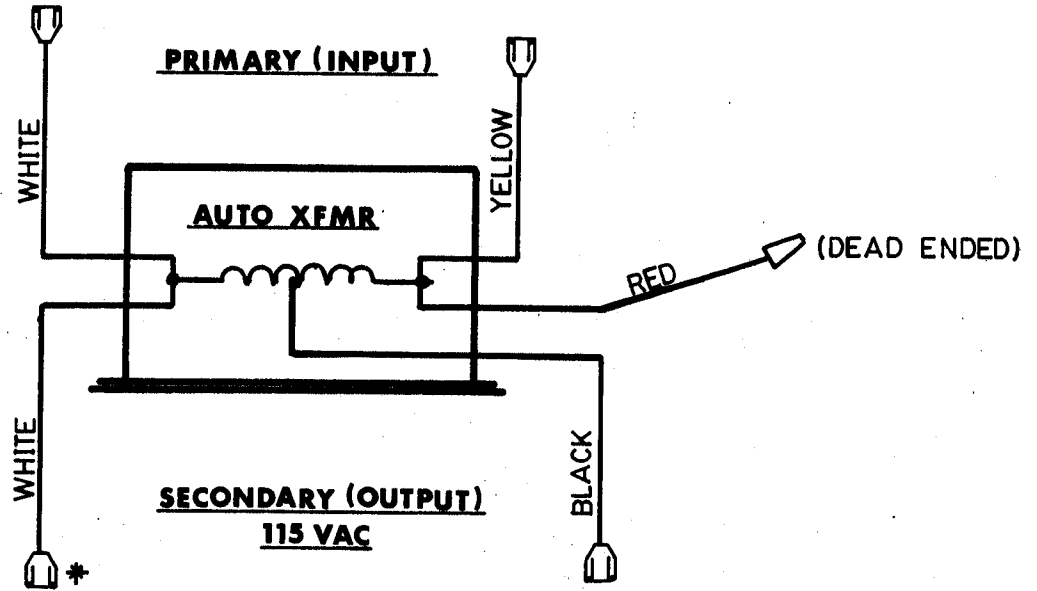

**230 Vac Controls**

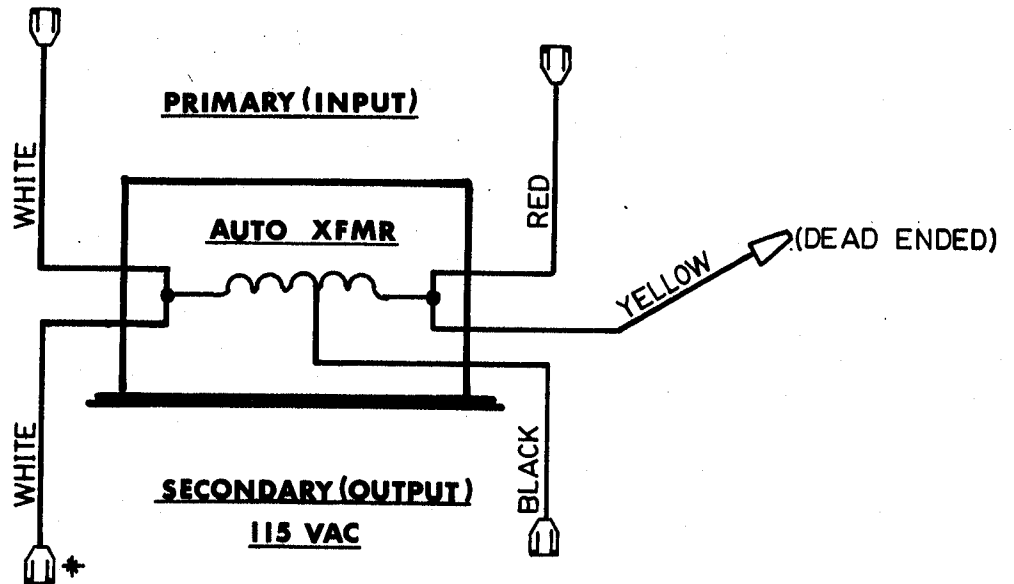

\* LEAD NOT USED ON COMPUTER HI/LO MODELS



SECTION X

Credit Card Orders

As a convenience to our customers, we have introduced the use of MASTERCARD and VISA to pay for your purchases.

When ordering parts by TELEPHONE, please have the following information available:

Billing Information

Name  
Address  
City, State, Zip Code  
Telephone Number  
Mastercard/Visa Number  
Expiration Date

Shipping Information

Name  
Address  
City, State, Zip Code

When ordering parts by MAIL, please complete and attach the card below with your order. We will keep this information on file for future shipments.

We look forward to handling your parts orders more expeditiously.

PLEASE PRINT

Name \_\_\_\_\_  
Street \_\_\_\_\_  
City \_\_\_\_\_ State \_\_\_\_\_ Zip \_\_\_\_\_  
Phone \_\_\_\_\_  
Home ( ) \_\_\_\_\_ Business ( ) \_\_\_\_\_

I hereby authorize American Dryer Corporation to use my \_\_\_\_\_ MasterCard \_\_\_\_\_ VISA number \_\_\_\_\_ to pay for my purchases from your firm. The card expires \_\_\_\_\_.



\_\_\_\_\_  
Signature

