



AD-30/AD-50 Parts Manual 24 VAC Phase 5 1992 thru 2002

American Dryer Corporation
88 Currant Road
Fall River, MA 02720-4781
Telephone: (508) 678-9000 / Fax: (508) 678-9447
e-mail: techsupport@amdry.com
www.amdry.com

Retain This Manual In A Safe Place For Future Reference

American Dryer Corporation products embody advanced concepts in engineering, design, and safety. If this product is properly maintained, it will provide many years of safe, efficient, and trouble free operation.

ONLY qualified technicians should service this equipment.

OBSERVE ALL SAFETY PRECAUTIONS displayed on the equipment or specified in the installation manual included with the dryer.

The following “**FOR YOUR SAFETY**” caution **must be** posted near the dryer in a prominent location.

FOR YOUR SAFETY

Do not store or use gasoline or other flammable vapors and liquids in the vicinity of this or any other appliance.

POUR VOTRE SÉCURITÉ

Ne pas entreposer ni utiliser d'essence ni d'autres vapeurs ou liquides inflammables à proximité de cet appareil ou de tout autre appareil.

We have tried to make this manual as complete as possible and hope you will find it useful. **ADC** reserves the right to make changes from time to time, without notice or obligation, in prices, specifications, colors, and material, and to change or discontinue models.

Important

For your convenience, log the following information:

DATE OF PURCHASE _____ **MODEL NO.** _____

RESELLER'S NAME _____

Serial Number(s) _____

Replacement parts can be obtained from your reseller or the **ADC** factory. When ordering replacement parts from the factory, you can FAX your order to **ADC** at (508) 678-9447 or telephone your order directly to the **ADC** Parts Department at (508) 678-9000. Please specify the dryer **model number** and **serial number** in addition to the **description** and **part number**, so that your order is processed accurately and promptly.

The illustrations on the following pages may not depict your particular dryer exactly. The illustrations are a composite of the various dryer models. Be sure to check the descriptions of the parts thoroughly before ordering.

“IMPORTANT NOTE TO PURCHASER”

Information **must be** obtained from your local gas supplier on the instructions to be followed if the user smells gas. These instructions **must be** posted in a prominent location near the dryer.

Table of Contents

AD-30 Coin Control and Single Timer Door Assembly	
For Models Mfd. as of July 2, 2002	4
AD-30 Control Door Assembly Without Trim	
For OPL (Non-Coin) Models Mfd. between July 19, 1999 and July 2, 2002	5
AD-30 High Security Control Door Assembly	
For Coin Models Mfd. prior to July 2, 2002 and OPL Models Mfd. prior to July 19, 1999	6
AD-50 Control Door Assembly	
For Models Mfd. as of July 2, 2002	7
AD-50 Control Door Assembly Without Trim	
For OPL (Non-Coin) Models Mfd. between November 28, 1998 and July 2, 2002	8
AD-50 High Security Control Door Assembly	
For Coin Models Mfd. prior to July 2, 2002 and OPL Models Mfd. prior to November 28, 1998	9
Phase 5 Coin Microprocessor Control Panel Assembly	10
Phase 5 OPL Microprocessor Control Panel Assembly	11
Phase 5 OPL Microprocessor Control Box Assembly	12
AD-30/AD-50 Coin Vault Assembly	13
Dual Timer “Tap Touch” Controls	
For Models Mfd. as of November 3, 2000	14
Dual Timer Control Panel Assembly	
For Models Mfd. prior to November 3, 2000	15
Dual Timer Control Box Assembly	16
Non-Microprocessor Coin Meter Control Panel Assembly	
For Models Mfd. as of February 4, 2002	17
Non-Microprocessor Coin Meter Control Panel Assembly	
For Models Mfd. prior to February 4, 2002	18
Non-Microprocessor Coin Meter Control Box Assembly	19
Slide Meter Case Assembly	
For Models Mfd. as of January 13, 1995	20

Slide Meter Case Assembly	
For Models Mfd. prior to January 13, 1995	21
Coin Meter Replacement Parts	22
“Plastic” Main Door Assembly	23
Main Door Switch For “Plastic” Door	24
AD-30 Front Panel Assembly For “Plastic” Door	25
AD-50 Front Panel Assembly For “Plastic” Door	26
AD-30 Cold Rolled Steel (CRS) Door Front Panel	27
AD-50 Cold Rolled Steel (CRS) Door Front Panel	28
Main Door Switch Assembly Cold Rolled Steel (CRS) Door	29
Main Door “Steel” Assembly	30
AD-30 Basket (Tumbler)/Support Assembly	31
AD-50 Basket (Tumbler)/Support Assembly	32, 33
AD-30 Drop Lint Door Assembly	
For Models Mfd. as of October 19, 2002	34
AD-30 Drop Lint Door Assembly Without Trim	
For OPL (Non-Coin) Models Mfd. between July 19, 1999 and October 19, 2002	35
AD-30 Drop Lint Door Assembly	
For Coin and OPL Models Mfd. prior to July 19, 1999	36
AD-50 Drop Lint Door Assembly	
For Models Mfd. as of October 7, 2002	37
AD-50 Drop Lint Door Assembly Without Trim	
For OPL (Non-Coin) Models Mfd. between November 28, 1999 and October 7, 2002	38
AD-50 Drop Lint Door Assembly	
For Coin and OPL Models Mfd. prior to November 28, 1998	39
AD-30 Lint Trap Assembly	40
AD-50 Lint Trap Assembly	41
AD-30/AD-50 Basket (Tumbler) Bearing Assembly	42, 43
AD-30 Non-Reversing T.E.F.C. Motor Mount Assembly	44, 45
AD-30 Reversing T.E.F.C. Motor Mount Assembly	46, 47
Idler Bearing Assembly	48, 49

AD-50 Non-Reversing T.E.F.C. Motor Mount Assembly	50, 51
AD-50 Reversing T.E.F.C. Motor Mount Assembly	52, 53
Sensor Bracket Assemblies	54, 55
ADG-30/ADG-50 Direct Spark Ignition (DSI) Burner Box Assembly	
For Models Mfd. as of April 10, 2000	56, 57
ADG-30/ADG-50 Direct Spark Ignition (DSI) Burner Assembly	
For Models Mfd. prior to April 10, 2000	58, 59
ADE-30/ADE-50 Electric Oven Assembly	60, 61
ADG-30/ADG-50 Sail Switch/Hi-Limit Assemblies	62, 63
Single-Phase (1 ϕ) Motor, Electric Relay Panel Assembly	64
3-Phase (3 ϕ) Motor, Electric Relay Panel Assembly	65
Microprocessor Reversing Rear Control Box Assembly	66
Dual Timer Reversing Rear Control Box Assembly	67
Slide Meter Control Box Assembly	
For Models Mfd. as of January 13, 1995	68
Slide Meter Control Box Assembly	
For Models Mfd. prior to January 13, 1995	69
ADS-30 Steam Coil/Air Operated Steam Damper Assembly	70, 71
ADS-30 Steam Coil/Mechanical Steam Damper Assembly	72, 73
ADS-50 Steam Coil/Air Operated Steam Damper Assembly	74, 75
ADS-50 Steam Coil/Mechanical Steam Damper Assembly Option	76, 77
ADG-30/ADG-50 Outer Top/Back Guard Assemblies	78
AD-30/AD-50 Heat Reclaimer Assembly	79
Microprocessor Coin Acceptors Listing	80
ADE-30/ADE-50 Step Down Transformer Usage Listing For Electric Dryers	81
ADE-30/ADE-50 Step Down Transformer Usage Listing For Gas/Steam Dryers	82
ADE-30/ADE-50 Electric Oven Component Application Charts	83
ADG-30/ADG-50 Direct Spark Ignition (DSI) Burner Assembly Specifications	84
Additional Parts Available	85

For Models Mfd. as of July 2, 2002

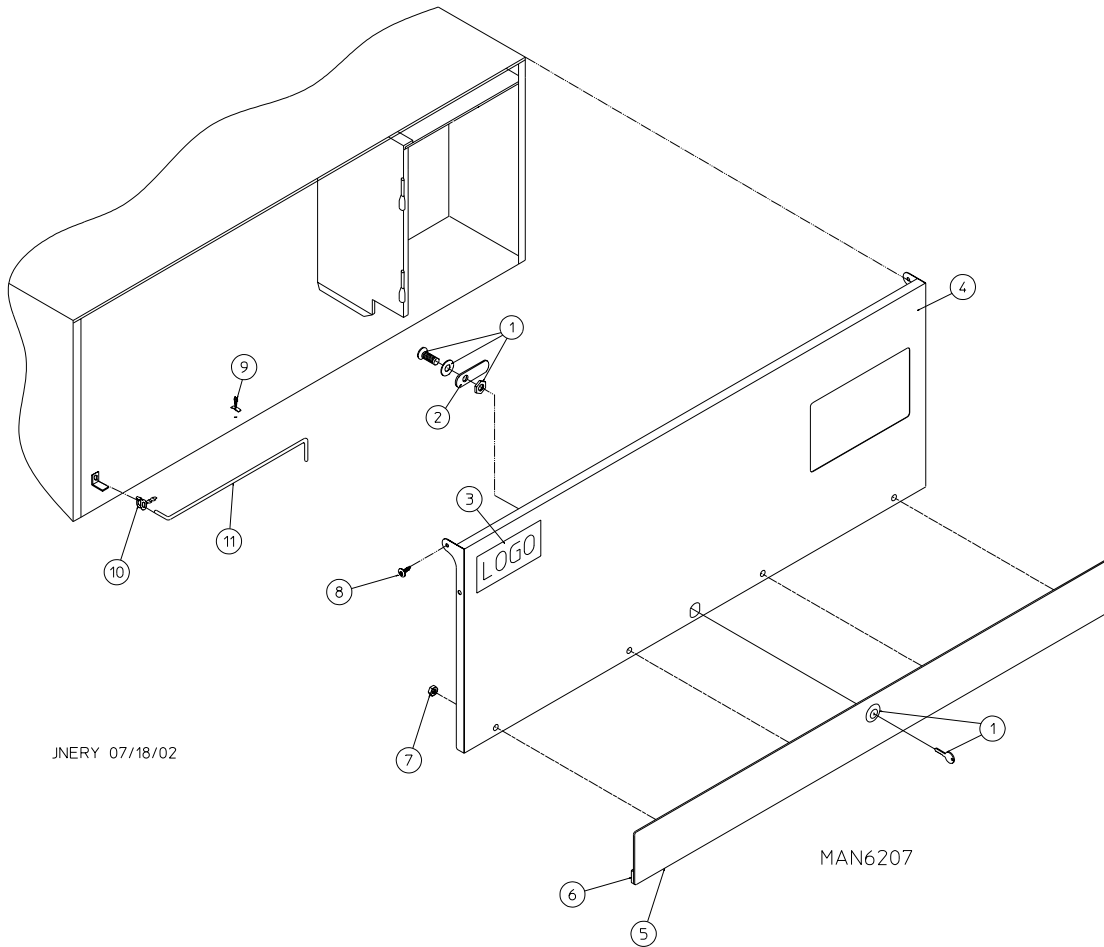

<u>Illus. No.</u>	<u>Part No.</u>	<u>Qty.</u>	<u>Description</u>
1	160015	1	High Security MK-100 Lock Assembly with Key (for coin models Only)
	160104	1	MK-100 Key ONLY
2	160016	1	Lock Cam ONLY
3	881053	1	ADC Logo with Tape
	870011	1	Double Sided Tape Kit
4	883416	1	White High Security Control Door Assembly with Black Trim (includes illus. nos. 4 through 7)
	883417	1	Stainless Steel High Security Control Door with Black Trim (includes illus. nos. 4 through 7)
	883418	1	Coral Blue High Security Door Assembly with Black Trim (includes illus. nos. 4 through 7)
	883419	1	Ivory High Security Door Assembly with Black Trim (includes illus. nos. 4 through 7)
5	883525	1	Top Black Trim Strip with Lock Hole
6	117604	6	Neoprene Sponge Tape (sold by the foot)
7	152014	4	1/4-20 Free Spin Wash Nut
8	150317	2	#10-16 x 3/4" TORX + BTN, Type 1
9	102603	1	Control Door Rod Support Catch
10	102601	1	Control Door Rod Retainer Clip
11	102502	1	Control Door Support Rod

For OPL (Non-Coin) Models Mfd. between July 19, 1999 and July 2, 2002

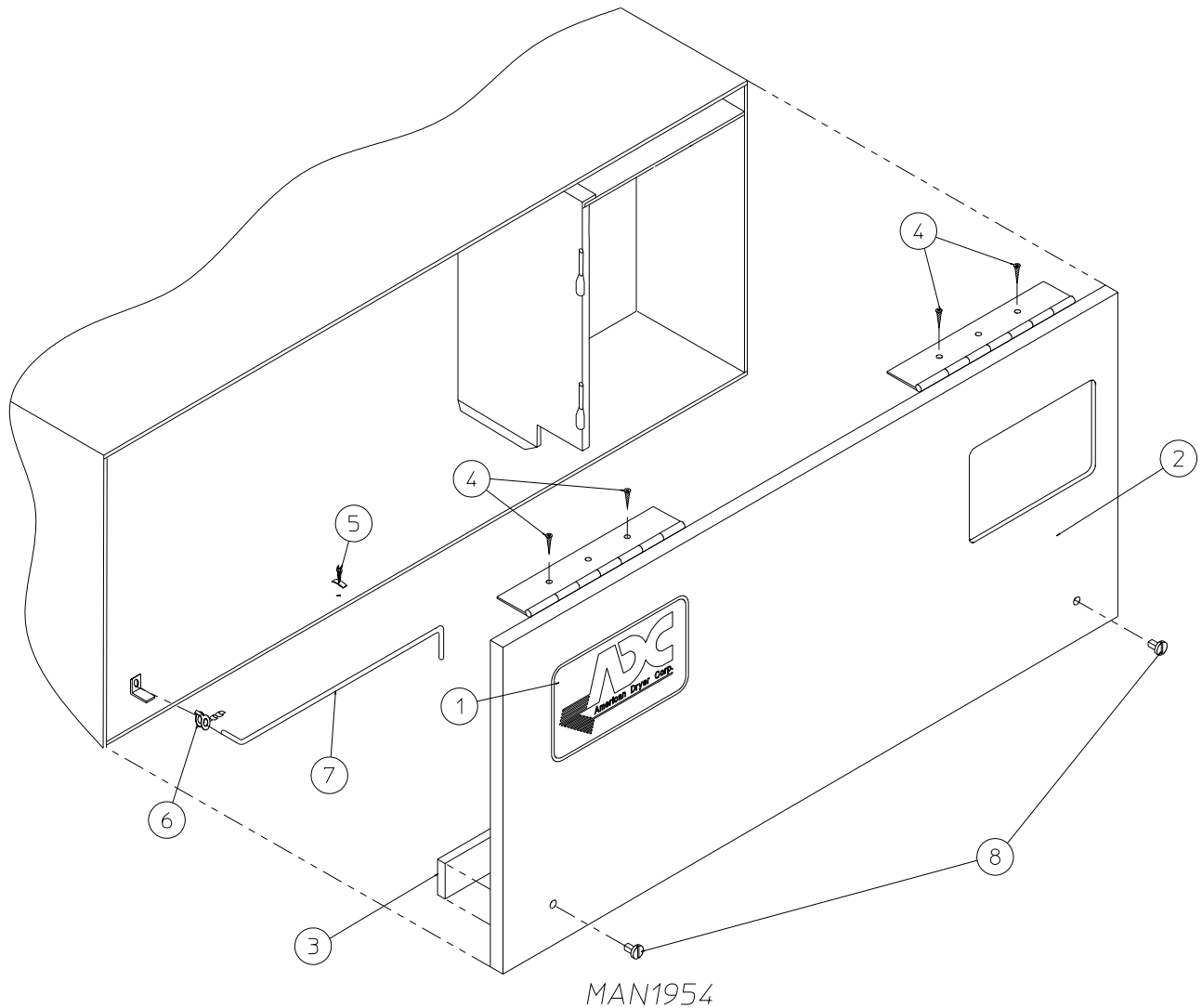

<u>Illus. No.</u>	<u>Part No.</u>	<u>Qty.</u>	<u>Description</u>
1	881053	1	ADC Logo ONLY (with double adhesive tape)
	870011	1	Logo Double Tape Kit
2	883097*	1	Control Door (includes illus. nos. 2 and 3)
3	117604	4	Neoprene Sponge Tape (sold by the foot)
4	150300	4	#10-16 x 1/2" Hex Washer TEK Screw
5	102603	1	Control Door Rod Support Catch
6	102601	1	Control Door Rod Retainer Clip
7	102502	1	Control Door Support Rod
8	882541	2	Spring Turn Latch Assembly

* Specify color when ordering.

For Coin Models Mfd. prior to July 2, 2002 and OPL Models Mfd. prior to July 19, 1999

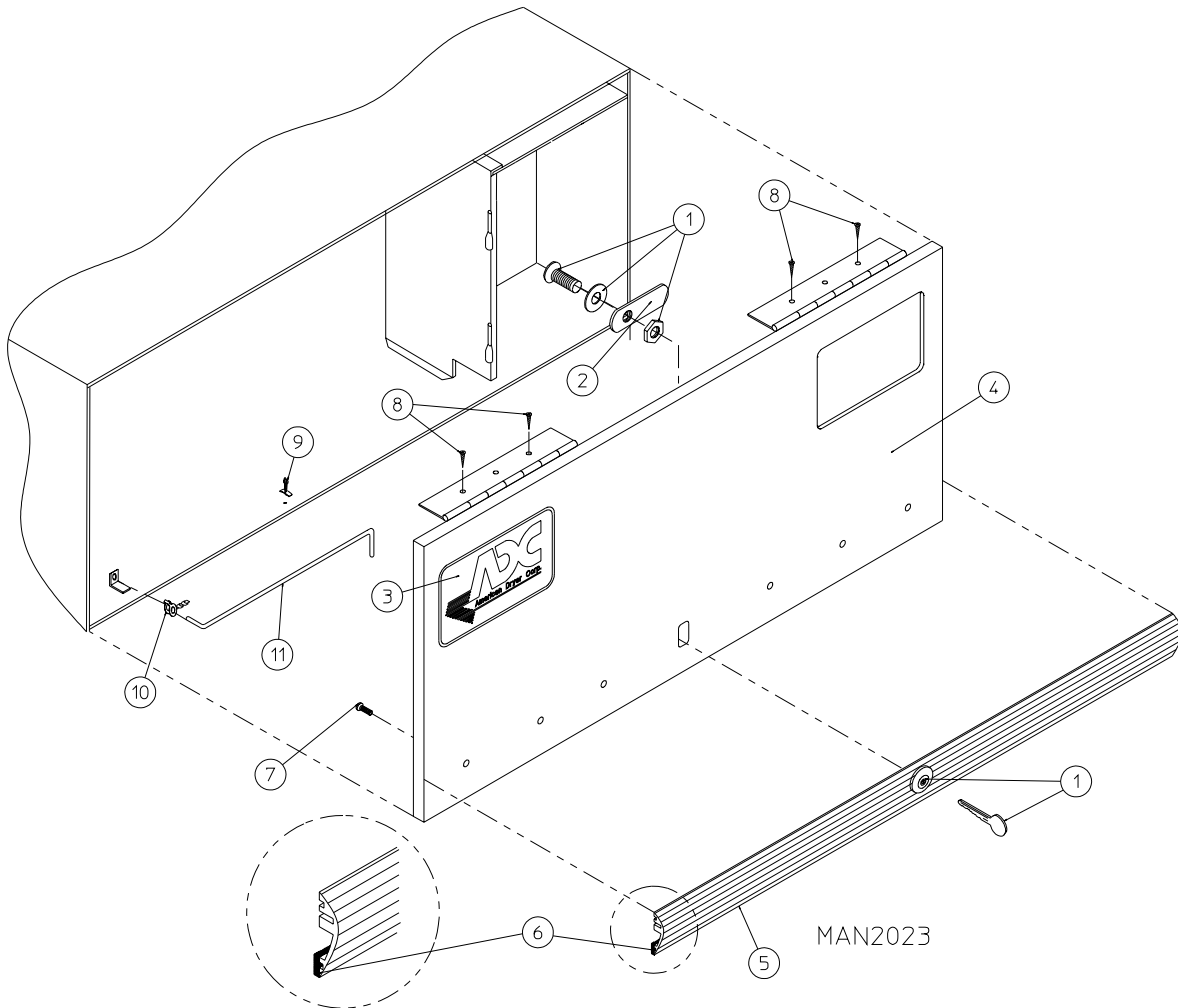

<u>Illus. No.</u>	<u>Part No.</u>	<u>Qty.</u>	<u>Description</u>
1	160015	1	High Security MK-100 Lock Assembly with Key
	160104	1	MK-100 Key ONLY
2	160016	1	Lock Cam ONLY
3	881053	1	ADC Logo with Tape
	870011	1	Double Sided Tape Kit
4	800023*	1	AD-30 High Security Control Door Assembly Less Lock (includes illus. nos. 4 through 7)
	800140	1	AD-30 Stainless Steel High Security Control Door Assembly Less Lock (includes illus. nos. 4 through 7)
5	180200	1	AD-30 Top Gray Trim Strip with Lock Hole
6	117603	3	Noise Suppressor Tape (sold by the foot)
7	150201	5	#10-32 x 1/4" Phillips Round Head Machine Screw
8	150300	4	#10-16 x 1/2" Hex Washer TEK Screw
9	102603	1	Control Door Rod Support Catch
10	102601	1	Control Door Rod Retainer Clip
11	102502	1	Control Support Rod

* Specify color when ordering.

For Models Mfd. as of July 2, 2002

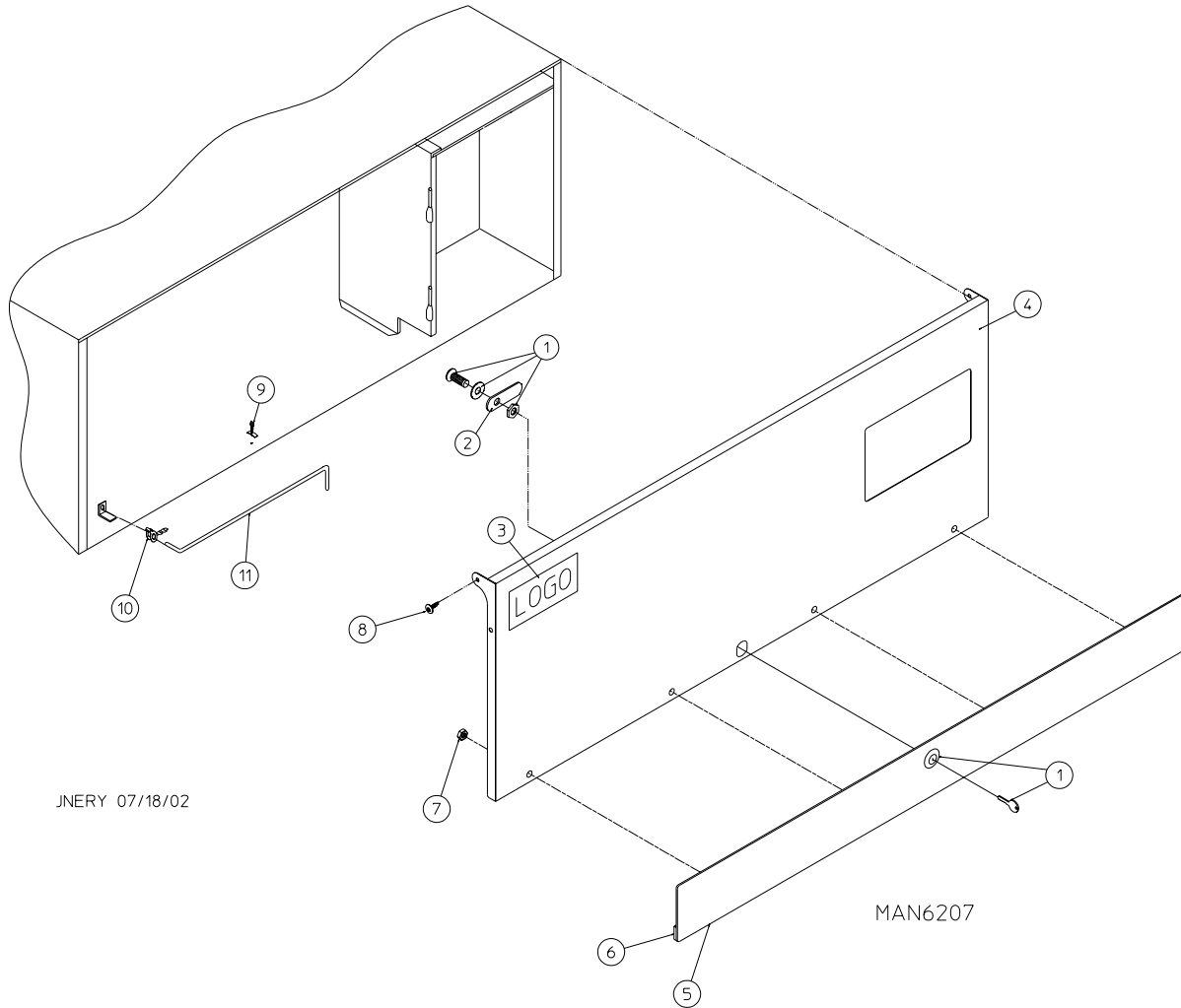

Illus. No.	Part No.	Qty.	Description
1	160015	1	High Security MK-100 Lock Assembly with Key (for coin models Only)
	160104	1	MK-100 Key ONLY
2	160016	1	Lock Cam ONLY
3	881053	1	ADC Logo with Tape
	870011	1	Double Sided Tape Kit
4	883477	1	White High Security Control Door Assembly with Black Trim (includes illus. nos. 4 through 7)
	883549	1	Coral Blue High Security Door Assembly with Black Trim (includes illus. nos. 4 through 7)
	883478	1	Ivory High Security Door Assembly with Black Trim (includes illus. nos. 4 through 7)
5	883525	1	Top Black Trim Strip with Lock Hole
6	117604	6	Neoprene Sponge Tape (sold by the foot)
7	152014	4	1/4-20 Free Spin Wash Nut
8	150317	2	#10-16 x 3/4" TORX + BTN, Type 1
9	102603	1	Control Door Rod Support Catch
10	102601	1	Control Door Rod Retainer Clip
11	102502	1	Control Door Support Rod

For OPL (Non-Coin) Models Mfd. between November 28, 1998 and July 2, 2002

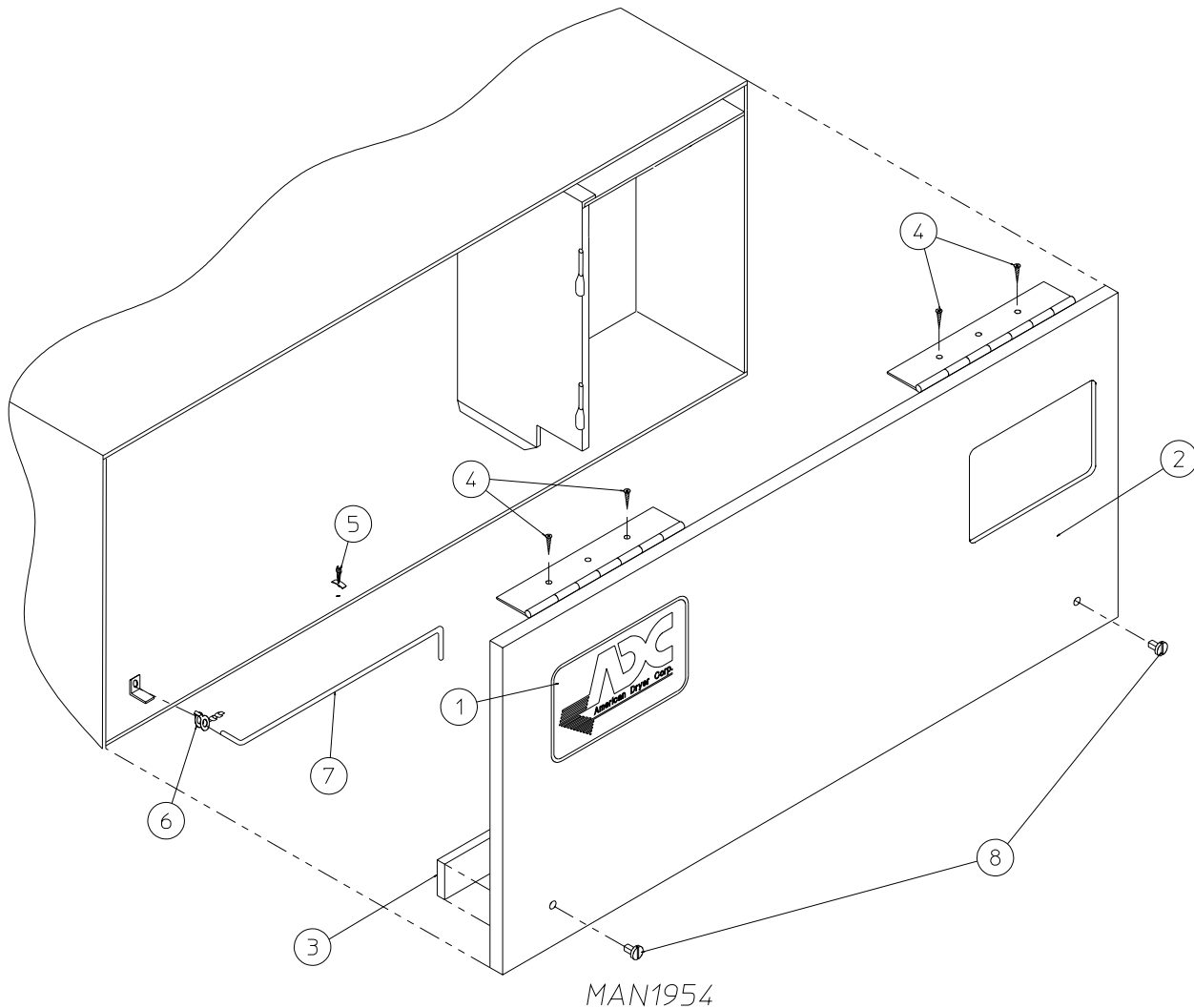

<u>Illus. No.</u>	<u>Part No.</u>	<u>Qty.</u>	<u>Description</u>
1	881053	1	ADC Logo ONLY (with double adhesive tape)
	870011	1	Logo Double Tape Kit
2	882265*	1	Control Door (includes illus. nos. 2 and 3)
3	117604	4	Neoprene Sponge Tape (sold by the foot)
4	150300	4	#10-16 x 1/2" Hex Washer TEK Screw
5	102603	1	Control Door Rod Support Catch
6	102601	1	Control Door Rod Retainer Clip
7	102502	1	Control Door Support Rod
8	882541	2	Spring Turn Latch Assembly

* Specify color when ordering.

For Coin Models Mfd. prior to July 2, 2002 and OPL Models Mfd. prior to November 28, 1998

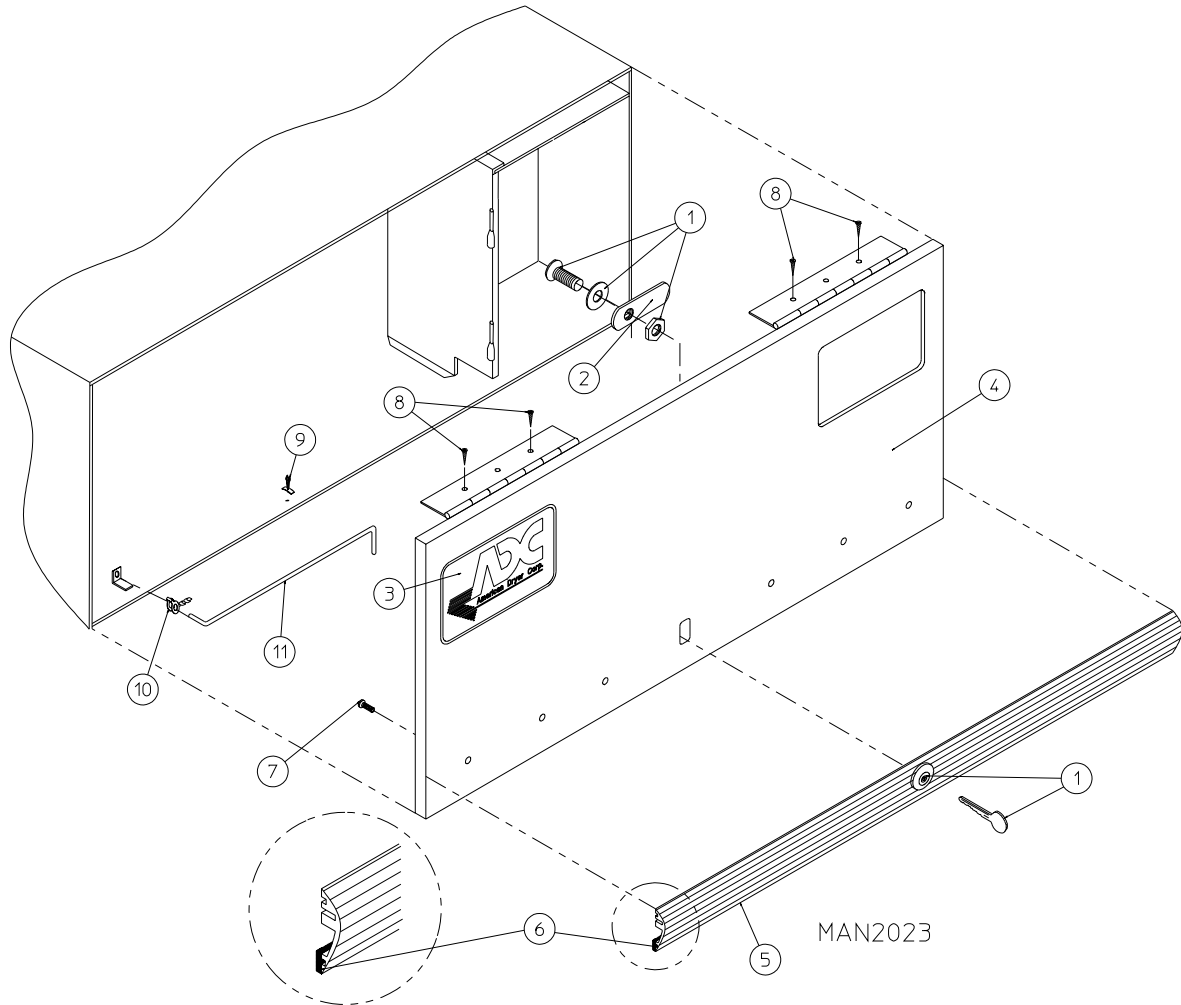

<u>Illus. No.</u>	<u>Part No.</u>	<u>Qty.</u>	<u>Description</u>
1	160015	1	High Security MK-100 Lock Assembly with Key (for coin models Only)
	160104	1	MK-100 Key ONLY
2	160016	1	Lock Cam ONLY
3	881053	1	ADC Logo with Tape
	870011	1	Double Sided Tape Kit
4	800022*	1	AD-50 High Security Control Door Assembly Less Lock (includes illus. nos. 4 through 7)
	800141	1	AD-50 Stainless Steel High Security Control Door Assembly Less Lock (includes illus. nos. 4 through 7)
5	180201	1	AD-50 Top Gray Trim Strip with Lock Hole
6	117603	3	Noise Suppressor Tape (sold by the foot)
7	150201	5	#10-32 x 1/4" Phillips Round Head Machine Screw
8	150300	4	#10-16 x 1/2" Hex Washer TEK Screw
9	102603	1	Control Door Rod Support Catch
10	102601	1	Control Door Rod Retainer Clip
11	102502	1	Control Door Support Rod

* Specify color when ordering.

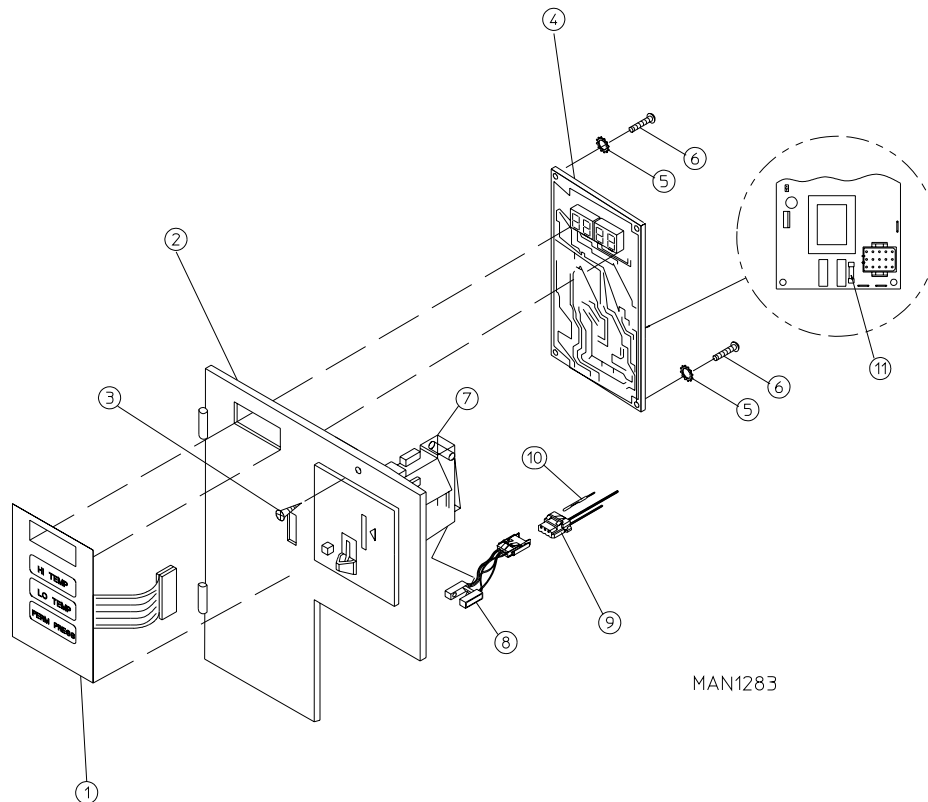

MAN1283

<u>Illus. No.</u>	<u>Part No.</u>	<u>Qty.</u>	<u>Description</u>
1	112526	1	Coin Keyboard Label Assembly
2	801213	1	Phase 5 Coin Control Panel Assembly (includes illus. nos. 1, 2, and 4 through 6)
	801229	1	Phase 5 Coin Control Panel Assembly with Battery Option (includes illus. nos. 1, 2, and 4 through 6)
	801259	1	Coin Control Panel ONLY
	801258	1	Coin Control Panel ONLY with Battery Bracket
3	150309	1	#10-16 x 1/2" Hex Head TEK Crimptite Screw
4	137213	1	Phase 5 Coin Controller ONLY
	824998	1	Phase 5 Battery Clip
5	153010	2	#6 Star Washer
6	150005	2	#6-32 x 1/4" Phillips Round Head Machine Screw
7	-----	1	Microprocessor Coin Acceptor with Optical Switch (refer to Microprocessor Coin Acceptors Listing on page 80)
8*	137056	1	Optic Switch ONLY
9*	137023	1	Optic Switch Connector ONLY
10*	137021	3	Microprocessor Socket ONLY
	880772	1	Single Coin Optical Switch Harness
	824080	1	Dual Coin Optical Switch Harness
	122800	1	Microprocessor (female) Pin Extraction Tool
11	136048	1	1/8-Amp (Slo-Bl) Fuse

* For dual coin models double the quantity shown.

IMPORTANT: Check label on computer chip to verify correct part number of controller (computer).

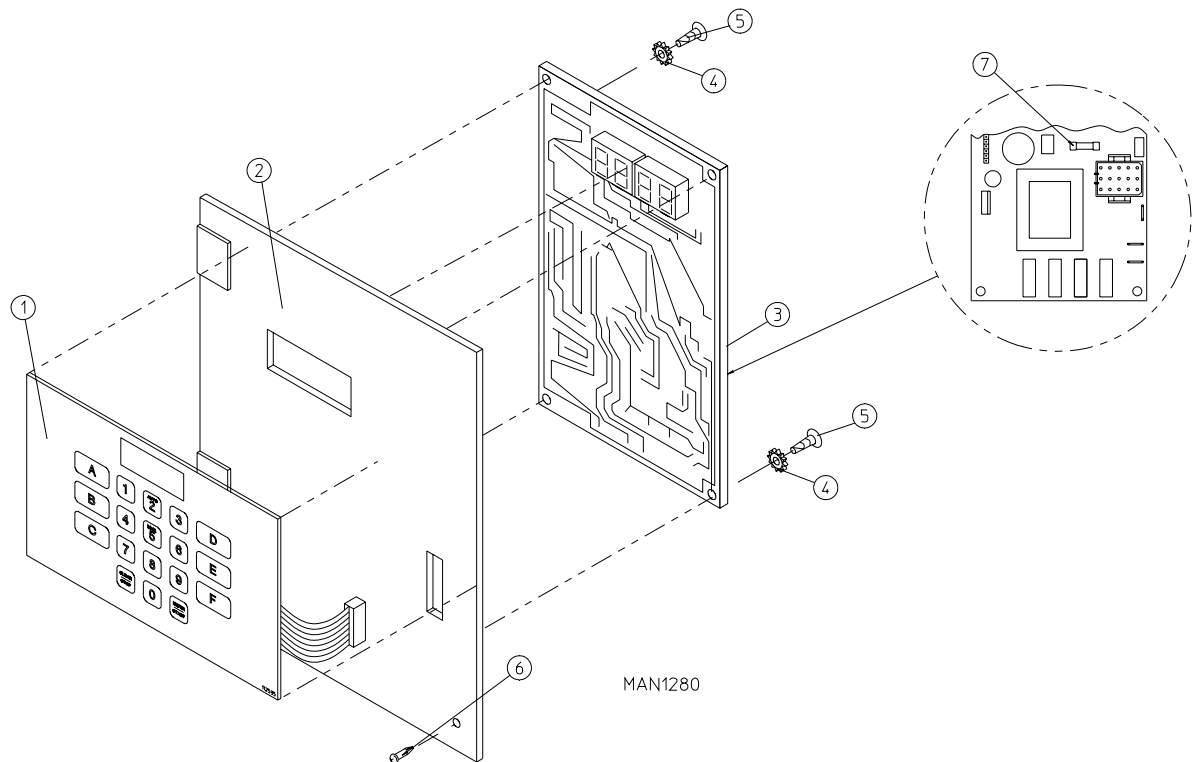

<u>Illus. No.</u>	<u>Part No.</u>	<u>Qty.</u>	<u>Description</u>
1	112535	1	OPL English Keyboard Label Assembly
	112276	1	OPL Stick-On Labels (English Only)...Not Included
	112275	1	3-Language OPL Stick-On Labels (Spanish, Italian, and Hebrew)...Not Included
	112277	1	3-Language OPL Stick-On Labels (English, Spanish, and Hebrew)...Not Illustrated
	112278	1	5-Language OPL Stick-On Labels (Italian, Dutch, French, German, and Chinese)...Not Illustrated
2	801255	1	Phase 5 Microprocessor Control Panel ONLY
	801256	1	Phase 5 Microprocessor Control Panel ONLY with Battery Bracket
	801206	1	Phase 5 OPL Non-Reversing Microprocessor Control Panel Assembly Complete (includes illus. nos. 1 through 6)
	801207	1	Phase 5 OPL Reversing Microprocessor Control Panel Assembly Complete (includes illus. nos. 1 through 6)
3	137222	1	Phase 5 OPL Non-Reversing Controller ONLY
	137231	1	Phase 5 OPL Reversing Controller ONLY
	824998	1	Phase 5 Battery Clip
4	153010	2	#6 Star Washer
5	150005	2	#6-32 x 1/4" Phillips Round Head Machine Screw
6	150309	1	#10-16 x 1/2" Hex Head TEK Crimptite Screw
	882541	1	Spring Turn Latch Assembly...Not Illustrated (for models mfd. prior to March 1, 1994)
7	136048	1	1/8-Amp (Slo-Blo) Fuse

IMPORTANT: Check label on computer chip to verify correct part number for controller (computer).

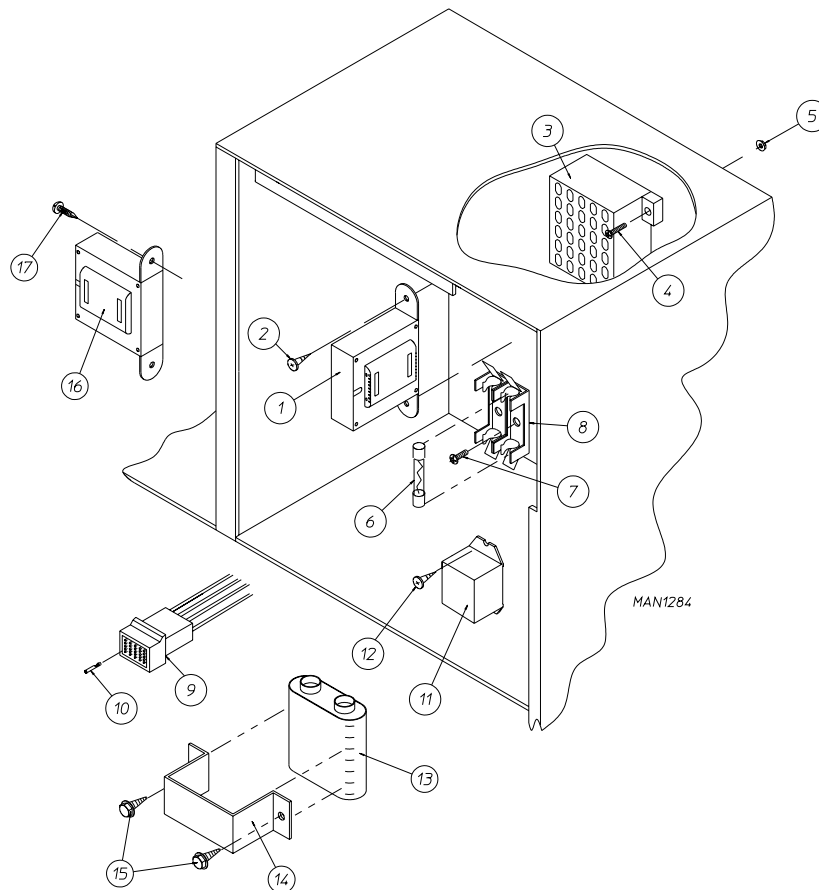

<u>Illus. No.</u>	<u>Part No.</u>	<u>Qty.</u>	<u>Description</u>
1	-----	1	Control Voltage Transformer - 24 VAC (refer to ADE-30/ADE-50 Step Down Transformer Usage Listing For Electric Dryers on page 81) (refer to ADE-30/ADE-50 Step Down Transformer Usage Listing For Gas/Steam Dryers on page 82)
2	150300	2	#10-16 x 1/2" Hex Washer TEK Screw
3	120715	1	30-Position Terminal Block
4	150002	2	#6-32 x 1" Slotted Round Head Machine Screw
5	151000	2	#6-32 Pal Nut
6	136057	*	1/2-Amp (Slo-Blo) Fuse
7	150301	*	#8-18 x 7/16" Phillips Pan Head TEK Screw
8	136008	*	Fuse Block/Strip ONLY
9	122641	1	15-Pin Microprocessor Connector
10	122706	*	Socket Terminal ONLY
11	131931	1	Steam Valve Relay (for mechanical steam damper models Only) - 24 VAC
12	150309	2	#10-16 x 1/2" Hex Head TEK CrimpTite Screw
13	137035	1	Motor Capacitor (for mechanical steam damper models Only)
14	323583	1	Capacitor Bracket (for mechanical steam damper models Only)
15	150300	2	#10-16 x 1/2" Hex Washer TEK Screw
16	132002	1	Transformer (for mechanical steam damper models - 208 VAC and higher)
17	150300	2	#10-16 x 1/2" Hex Washer TEK Screw

* As required.

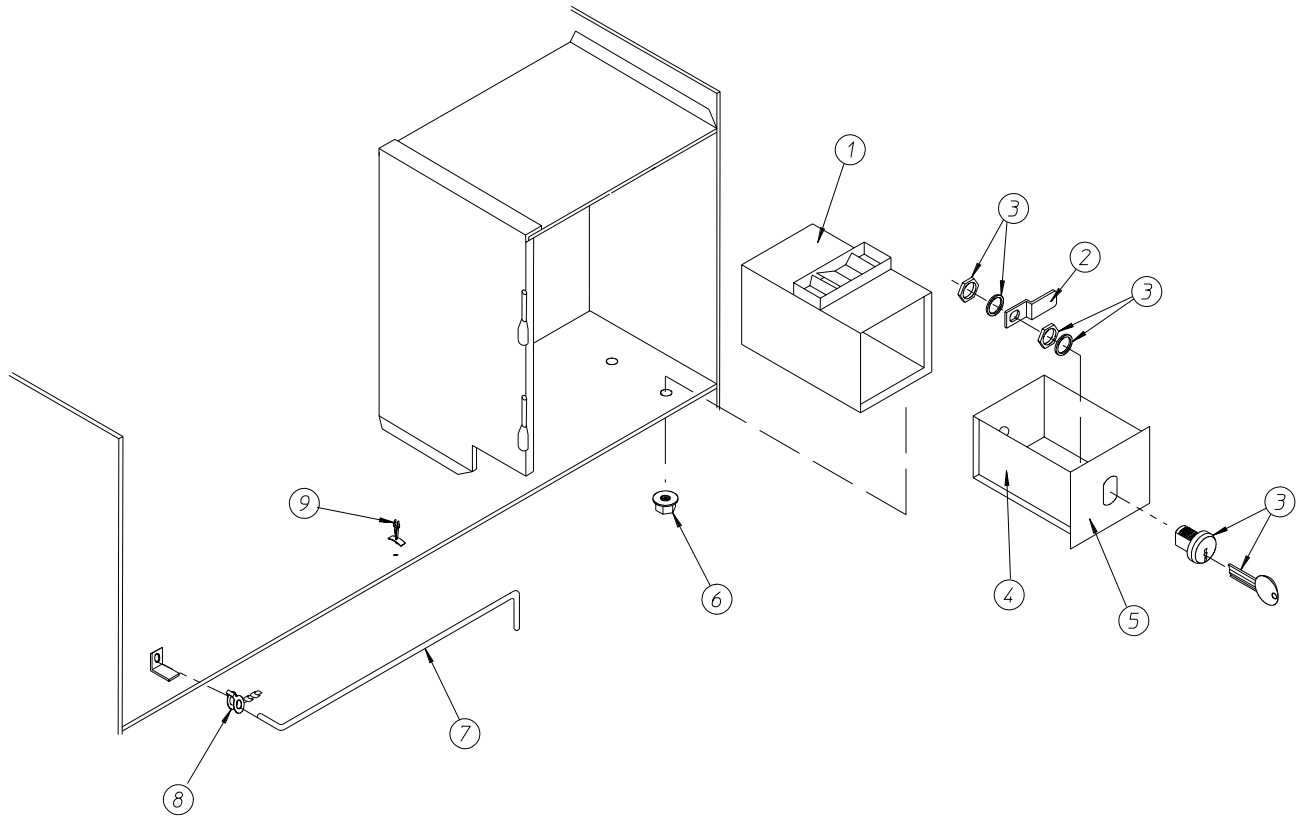

MAN1734

<u>Illus. No.</u>	<u>Part No.</u>	<u>Qty.</u>	<u>Description</u>
1	802112	1	Microprocessor Coin Vault Assembly Complete (includes illus. nos. 1 through 6)
	802117	1	Microprocessor Coin Vault ONLY
	802110	1	Non-Microprocessor Coin Vault Assembly Complete (includes illus. nos. 1 through 6)
	802115	1	Non-Microprocessor Coin Vault ONLY
2	160028	1	Cam for 1/4 Turn Lock ONLY
3	875061	1	1/4 Turn Lock with Key and Cam
	160105*	1	1/4 Turn Mer-Pel Key ONLY
4	802020	1	1/4 Turn Coin Box Assembly (includes illus. nos. 2 through 5)
	802019	1	1/4 Turn Coin Box ONLY without Faceplate
	125915	1	High Security (Greenwald) Coin Box ONLY with Key
5	802018	1	1/4 Turn Coin Box Faceplate ONLY
6	152014	4	1/4-20 Free Spin Wash Nut
7	102502	1	Control Door Support Rod
8	102601	1	Control Door Rod Retainer Clip
9	102603	1	Control Door Rod Catch

* Specify key number when ordering.

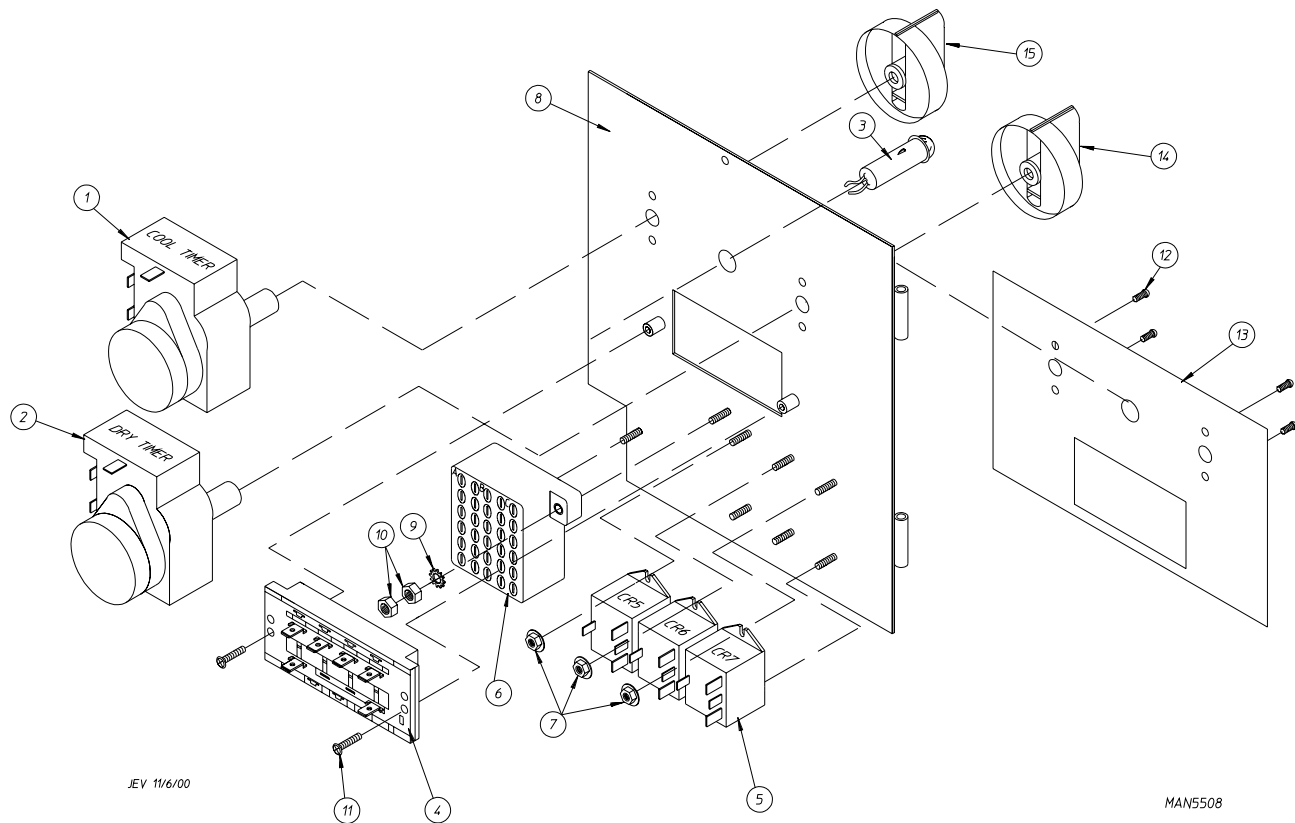

<u>Illus. No.</u>	<u>Part No.</u>	<u>Qty.</u>	<u>Description</u>
1	124030	1	15 Minute Timer - 24 VAC
2	124025	1	60 Minute Timer - 24 VAC
3	824175	1	Red Pilot Light - 24 VAC
4	122301	1	"Tap Touch" Switch
5	131932	3	Relay SPST 24v
6	120730	1	30-Position Terminal Block
7	151000	6	#6-32 Pal Nut
8	882903	1	Dual Timer Panel Complete (includes illus. nos. 1 through 15)
	850392	-	Dual Timer Panel ONLY
9	153010	2	#6 Star Washer
10	152000	3	#6-32 Hex Nut
11	150207	2	#10-24 x 1/2" Phillips Pan Head Machine Screw
12	150110	4	#8-32 x 1/4" Phillips Round Head Machine Screw
13	112563	1	Dual Timer Panel Overlay
14	124104	1	Pure Touch Knob with Red Pointer
15	124105	1	Pure Touch Knob with Blue Pointer

For Models Mfd. prior to November 3, 2000

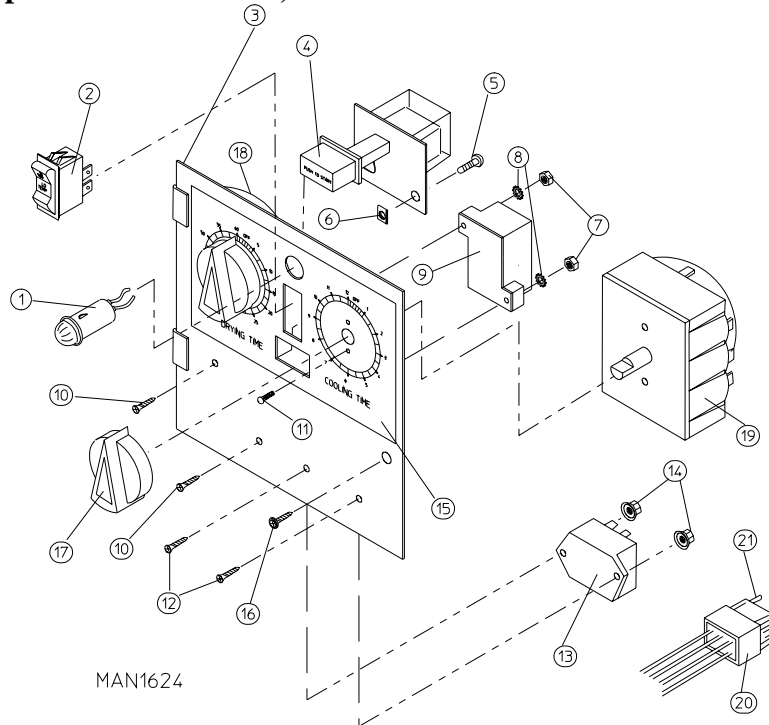

<u>Illus. No.</u>	<u>Part No.</u>	<u>Qty.</u>	<u>Description</u>
1	123005	1	Red Indicator Light - 24 VAC
2	122400	1	Rocker Heat Selector Switch
3	824015	1	Dual Timer Control Panel Assembly Complete - 24 VAC (includes illus. nos. 1 through 21)
	800051	1	Dual Timer Control Panel ONLY
4	131917	1	Push-To-Start Relay - 24 VAC
5	150207	2	#10-24 x 1/2" Round Head Machine Screw
6	154001	2	#10-24 Speed Nut
7	152000	2	#6-32 Hex Nut
8	153010	2	#6 Star Washer
9	120730	1	18-Position Terminal Block
10	150002	2	#6-32 x 1" Phillips Round Head Machine Screw
11	150110	4	#8-32 x 1/4" Phillips Machine Screw
12	150001	2	#6-32 x 1/2" Phillips Round Head Machine Screw
13	131931	1	Dual Timer Relay - 24 VAC
14	151000	2	#6-32 Pal Nut
15	112050	1	Dual Timer Label ONLY
16	150309	1	#10-16 x 1/2" Hex Head TEK Crimptite Screw (for models mfd. as of March 1, 1994)
	160005	1	Spring Turn Latch (2-piece)...Not Illustrated (for models mfd. prior to March 1, 1994)
17	124103	2	Arrow Timer Knob
18	124025	1	60 Minute Timer - 24 VAC
19	124030	1	15 Minute Timer - 24 VAC
20	122602	1	9-Pin Connector ONLY
21	122700	8	Pin Terminal ONLY
	122801	1	Pin/Socket Extraction Tool...Not Illustrated

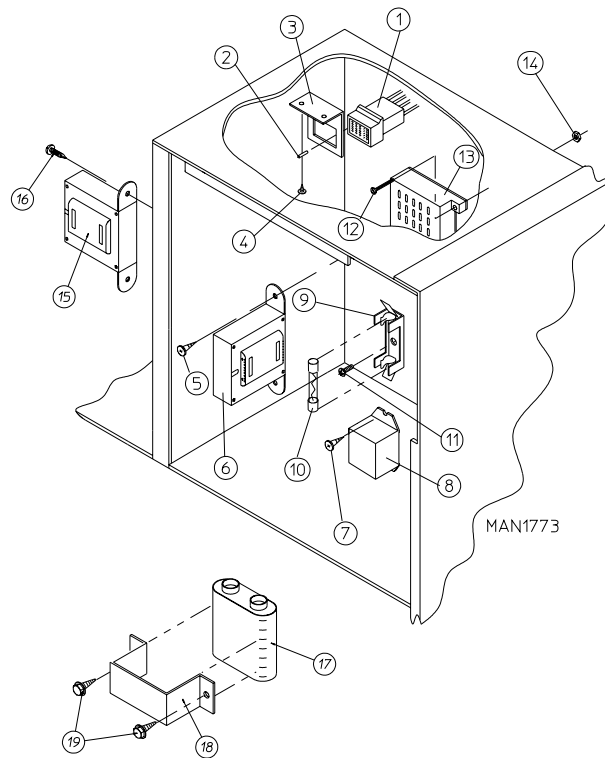

<u>Illus. No.</u>	<u>Part No.</u>	<u>Qty.</u>	<u>Description</u>
1	122603	1	9-Pin Socket Connector
2	122701	9	Socket Terminal ONLY
	122801	1	Pin/Socket Extraction Tool...Not Illustrated
3	315010	1	9-Pin Connector Bracket
4	150300	2	#10-16 x 1/2" Hex Washer TEK Screw
5	150300	2	#10-16 x 1/2" Hex Washer TEK Screw
6	-----	1	Transformer (refer to ADE-30/ADE-50 Step Down Transformer Usage Listing For Electric Dryers on page 81) (refer to ADE-30/ADE-50 Step Down Transformer Usage Listing For Gas/Steam Dryers on page 82)
7	150309	2	#10-16 x 1/2" Hex Head TEK Crimpite Screw
8	131931	1	Steam Valve Relay (for mechanical steam damper models Only) - 24 VAC
9	136008	*	Fuse Block/Strip ONLY
10**	136057	*	1/2-Amp (Slo-Blo) Fuse
11	150301	*	#8-18 x 7/16" Phillips Pan Head TEK Screw
12	150002	2	#6-32 x 1" Slotted Round Head Machine Screw
13	120715	1	30-Position Terminal Block
14	151000	2	#6-32 Pal Nut
15	132002	1	Transformer (for mechanical steam damper - 208 VAC and higher)
16	150300	2	#10-16 x 1/2" Hex Washer TEK Screw
17	137035	1	Motor Capacitor (for mechanical steam damper models Only)
18	323583	1	Capacitor Bracket (for mechanical steam damper models Only)
19	150300	2	#10-16 x 1/2" Hex Washer TEK Screw

* As required.

** Check fuse rating for verification.

For Models Mfd. as of February 4, 2002

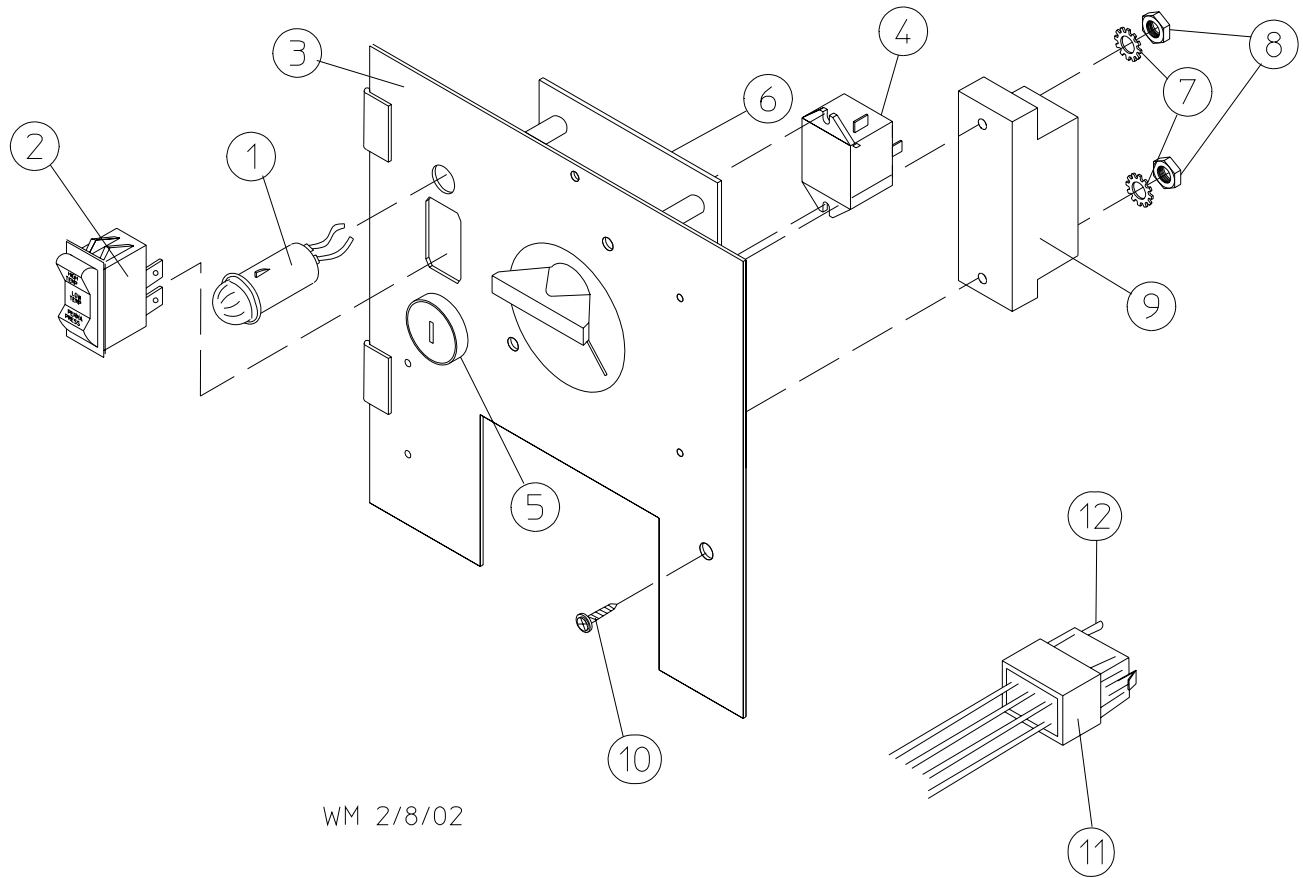

WM 2/8/02

MAN6086

<u>Illus. No.</u>	<u>Part No.</u>	<u>Qty.</u>	<u>Description</u>
1	123005	1	Red Indicator Light - 24 VAC
2	122400	1	Rocker Heat Selector Switch
3	824172	1	Coin Meter Control Panel Assembly Less Coin Meter (includes illus. nos. 1 through 5, 7, and 8)
	824109	1	Coin Meter Control Panel ONLY
4	131932	1	24 VAC Relay
	154001	2	#10-24 Speed Nut (used on P/N 131932, 24 VAC Relay)
5	123225	1	Green Push-To-Start Button
6	125601	1	25¢ Coin Meter - 24 VAC (specify timing)
7	153010	2	#6 Star Washer
8	152016	2	Hex Nut
9	120712	1	12-Position Terminal Block
10	150415	1	#10-16 x /12" Phillips Round Head CrimpTite Screw
11	122602	1	9-Pin Connector
12	122700	7	Pin Terminal ONLY
	122801	1	Pin/Socket Extraction Tool...Not Illustrated

NOTE: For Coin Meter Replacement Parts refer to **page 22**.

For Models Mfd. prior to February 4, 2002

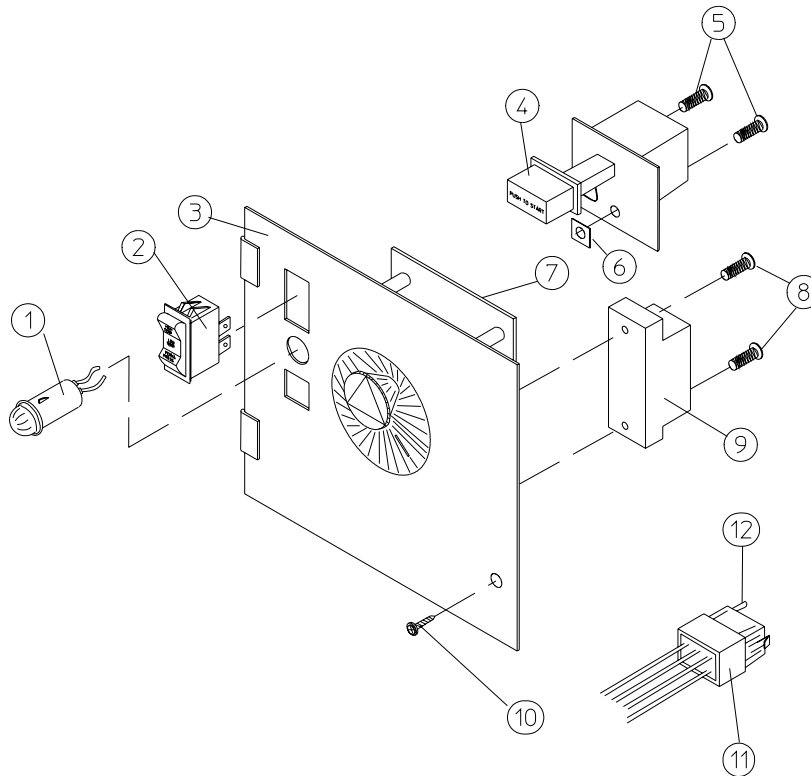

MAN1625

<u>Illus. No.</u>	<u>Part No.</u>	<u>Qty.</u>	<u>Description</u>
1	123005	1	Red Indicator Light - 24 VAC
2	122400	1	Rocker Heat Selector Switch
3	824020	1	Coin Meter Control Panel Assembly Complete - 24 VAC (includes illus. nos. 1 through 6 and 8 through 12)
	800054	1	Coin Meter Control Panel ONLY
4	131917	1	Push-To-Start Relay - 24 VAC
5	150207	2	#10-24 x 1/2" Round Head Machine Screw
6	154001	2	#10-24 Speed Nut
7*	125601	1	25¢ Coin Meter - 24 VAC (specify timing)
8	150303	2	#4 x 3/4" Pan Head "A" Screw
9	120712	1	12-Position Terminal Block
10	150309	1	#10-16 x 1/2" Hex Head TEK Crimptite Screw (for models mfd. as of March 3, 1994)
	160005	1	Spring Turn Latch (2-piece)...Not Illustrated (for models mfd. as of March 3, 1994)
11	122602	1	9-Pin Connector ONLY
12	122700	9	Pin Terminal ONLY
	122801	1	Pin/Socket Extraction Tool...Not Illustrated

* Consult factory for coin meters not listed.

NOTE: For Coin Meter Replacement Parts refer to **page 22**.

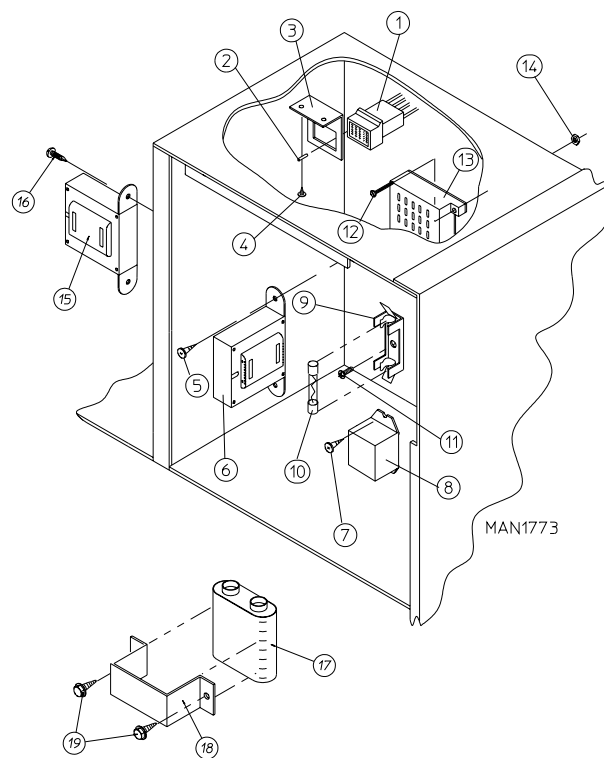

<u>Illus. No.</u>	<u>Part No.</u>	<u>Qty.</u>	<u>Description</u>
1	122603	1	9-Pin Socket Connector
2	122701	9	Socket Terminal ONLY
	122801	1	Pin/Socket Extraction Tool...Not Illustrated
3	315010	1	9-Pin Connector Bracket
4	150300	2	#10-16 x 1/2" Hex Washer TEK Screw
5	150300	2	#10-16 x 1/2" Hex Washer TEK Screw
6	-----	1	24 VAC Control Voltage Transformer (refer to ADE-30/ADE-50 Step Down Transformer Usage Listing For Electric Dryers on page 81) (refer to ADE-30/ADE-50 Step Down Transformer Usage Listing For Gas/Steam Dryers on page 82)
7	150309	2	#10-16 x 1/2" Hex Head TEK Crimptite Screw
8	131931	1	Steam Valve Relay (for mechanical steam damper models Only) - 24 VAC
9	136008	*	Fuse Block/Strip ONLY
10**	136057	*	1/2-Amp (Slo-Blo) Fuse
11	150301	*	#8-18 x 7/16" Phillips Pan Head TEK Screw
12	150002	2	#6-32 x 1" Slotted Round Head Machine Screw
13	120715	1	30-Position Terminal Block
14	151000	2	#6-32 Pal Nut
15	132002	1	Transformer (for mechanical steam damper 208 VAC and higher)
16	150300	2	#10-16 x 1/2" Hex Washer TEK Screw
17	137035	1	Motor Capacitor (for mechanical steam damper models Only)
18	323583	1	Capacitor Bracket (for mechanical steam damper models Only)
19	150300	2	#10-16 x 1/2" Hex Washer TEK Screw

* As required.

** Check fusing on dryer for verification.

For Models Mfd. as of January 13, 1995

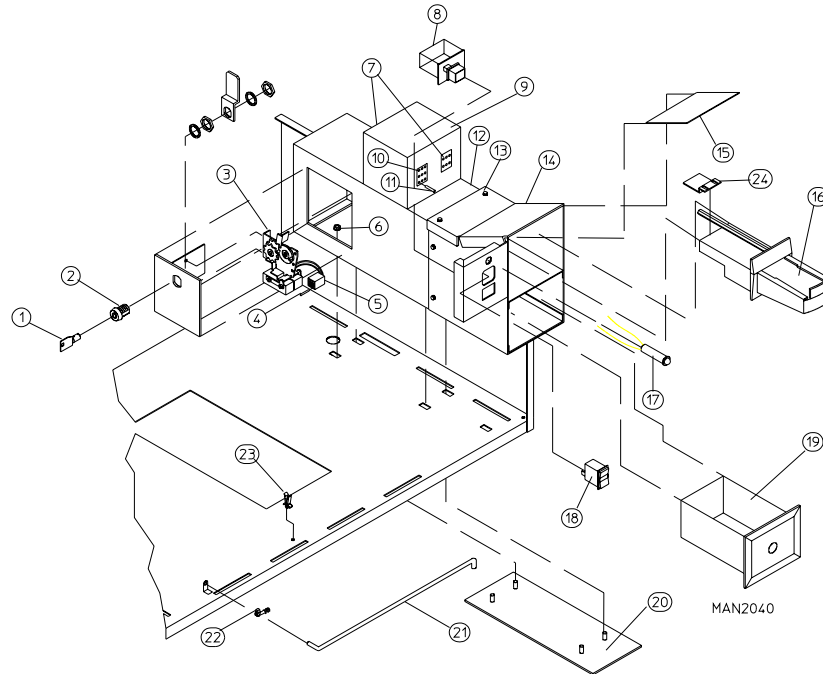

<u>Illus. No.</u>	<u>Part No.</u>	<u>Qty.</u>	<u>Description</u>
1*	160199	1	Key ONLY for Slide Meter Lock
2	160099	1	Lock/Key/Cam and Hardware
	883037	1	White Slide Meter Timer Door
3	125908	1	Slide Meter Accumulator - 24 VAC
4	122643	9	Mate-N-Lock Pin ONLY
5	122642	1	9-Position Mini-Universal Socket
6	152014	4	1/4-20 Free Spin Wash Nut
7	122631	2	6-Position Connector (mate-n-lock)
8	131917	1	Push-To-Start Relay - 24 VAC
9	881100	1	Slide Meter Modular J-Box Assembly
10	122603	1	9-Position Connector (mate-n-lock)
11	122701	21	Socket Terminal ONLY
12	125900	1	Slide Meter Case ONLY with Door Less Lock
13	154203	6	1/4" Drive Rivet
14	801700	1	Slide Meter Extension ONLY with Mirror (includes illus. nos. 14 and 15)
15	315404	1	Stainless Steel Mirror ONLY
16	-----	1	Typical Slide Meter Coin Chute (Not available from ADC)
17	123005	1	Red Indicator Light - 24 VAC
18	122400	1	Rocker Heat Selector Switch
19	-----	1	Typical Slide Meter Coin Box (Not available from ADC)
20	801701	1	Slide Meter Case Mounting Plate
21	102502	1	Control Door Support Rod
22	102601	1	Control Door Rod Retainer Clip
23	102600	1	Control Door Support Rod Catch
24	125903	1	Slide Meter Extension

* Specify key number when ordering.

For Models Mfd. prior to January 13, 1995

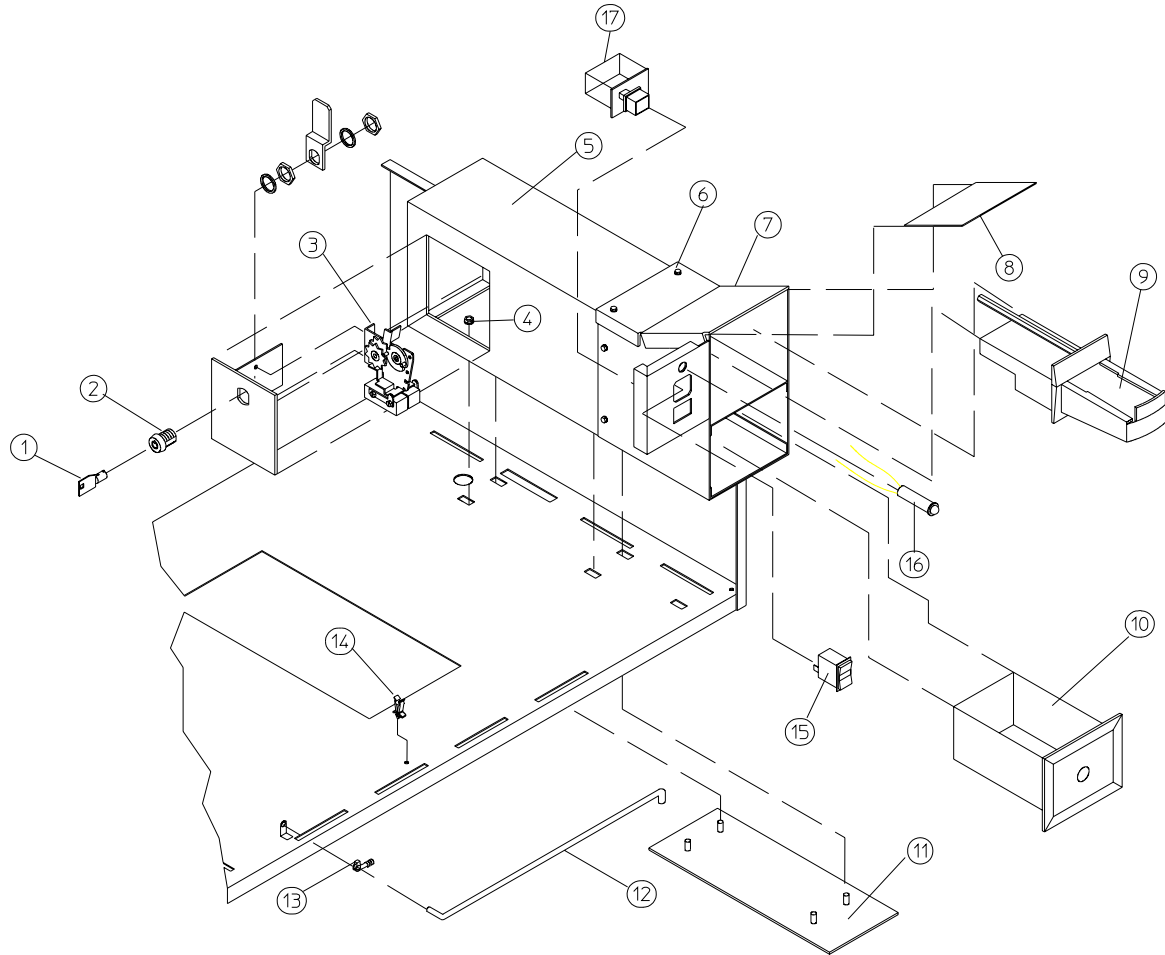

MAN0272

<u>Illus. No.</u>	<u>Part No.</u>	<u>Qty.</u>	<u>Description</u>
1*	160199	1	Key ONLY for Slide Meter Lock
2	160099	1	Lock/Key/Cam and Hardware
3	125908	1	Slide Meter Accumulator - 24 VAC
4	152014	4	1/4-20 Free Spin Wash Nut
5	125900	1	Slide Meter Case ONLY with Door Less Lock
6	154203	6	1/4" Drive Rivet
7	801700	1	Slide Meter Extension ONLY with Mirror (includes illus. nos. 7 and 8)
8	315404	1	Stainless Steel Mirror ONLY
9	-----	1	Typical Slide Meter Coin Chute (Not available from ADC)
10	-----	1	Typical Slide Meter Coin Box (Not available from ADC)
11	801701	1	Slide Meter Case Mounting Plate
12	102502	1	Control Door Support Rod
13	102601	1	Control Door Rod Retainer Clip
14	102600	1	Control Door Support Rod Catch
15	122400	1	Rocker Heat Selector Switch
16	123005	1	Red Indicator Light - 24 VAC
17	131917	1	Push-To-Start Relay - 24 VAC

* Specify key number when ordering.

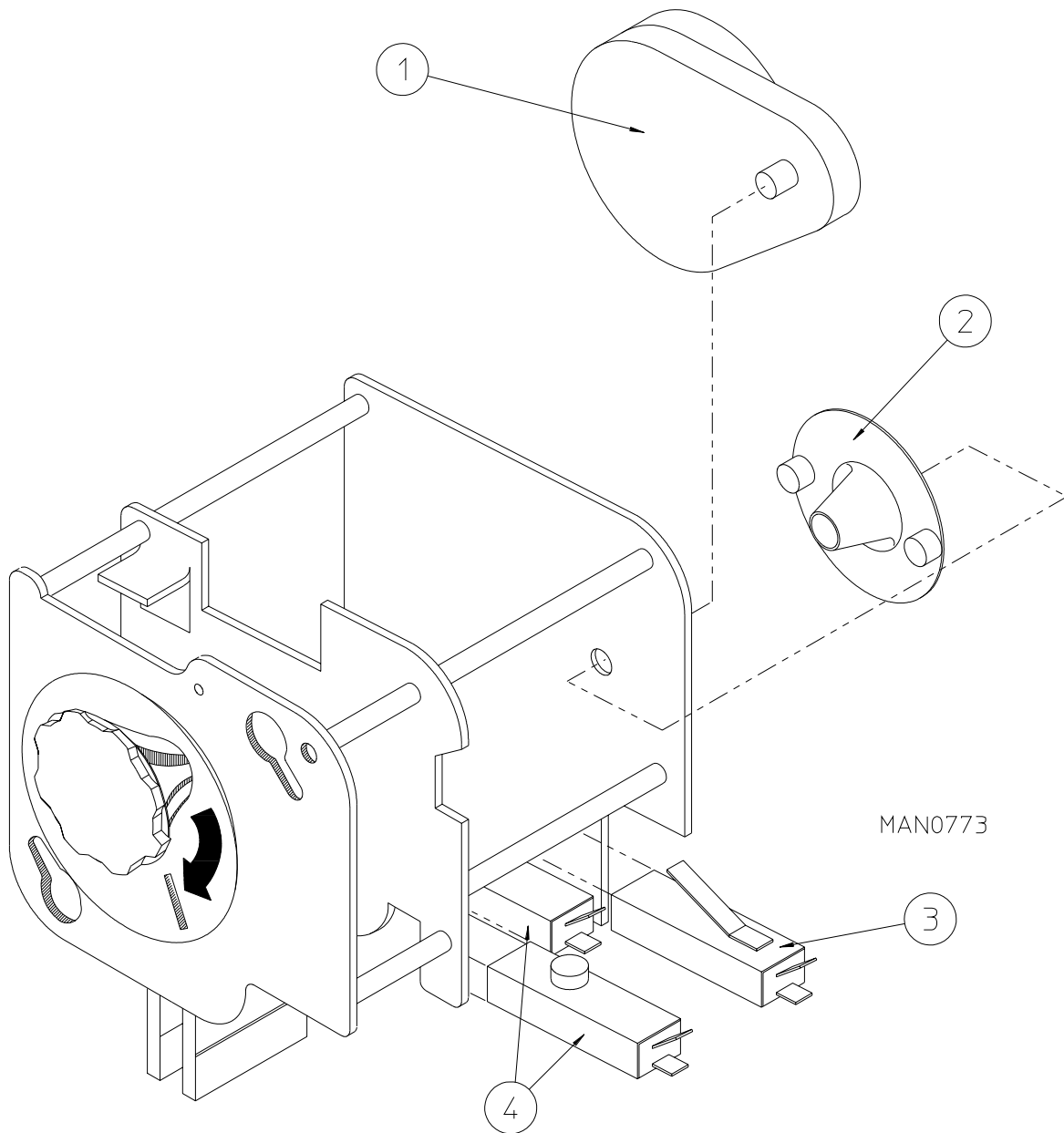

<u>Illus. No.</u>	<u>Part No.</u>	<u>Qty.</u>	<u>Description</u>
1	125541	1	1/60 RPM - 60 Hz Meter Motor - 24 VAC
	125540	1	1/30 RPM - 50 Hz Meter Motor - 24 VAC
2	125500	1	2-Point Cam
	125501	1	3-Point Cam
	125502	1	4-Point Cam
	125503	1	5-Point Cam
	125504	1	6-Point Cam
	125506	1	8-Point Cam
	125507	1	9-Point Cam
	125508	1	10-Point Cam
	125510	1	12-Point Cam
	3	125515	1
4	125516	2	Meter Switch "A" or "C"

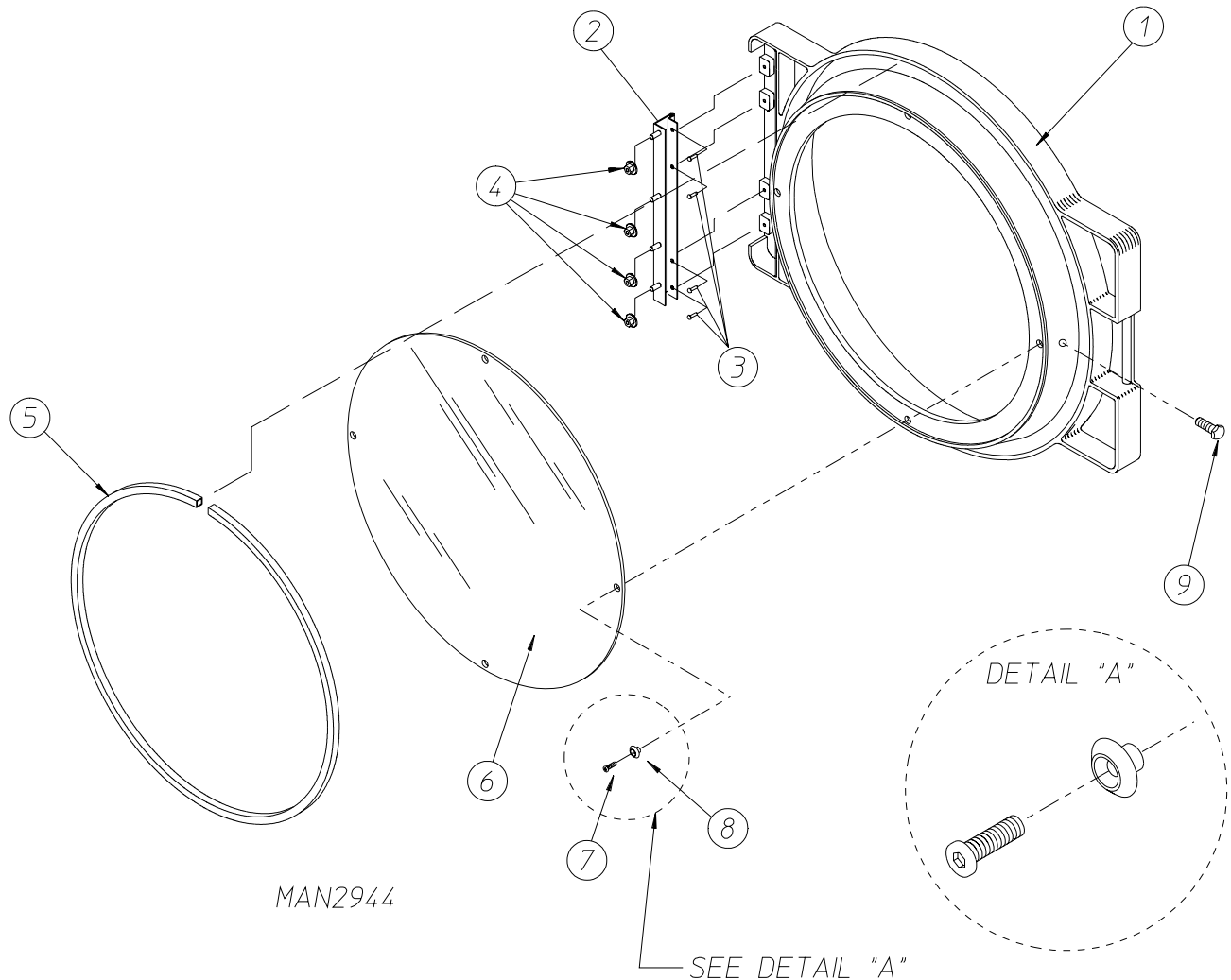

<u>Illus. No.</u>	<u>Part No.</u>	<u>Qty.</u>	<u>Description</u>
1	881421	1	Gray Plastic Main Door Assembly Complete with Mechanical Fasteners (includes illus. nos. 1 and 5 through 9)
	881422	1	Black Plastic Main Door Assembly Complete with Mechanical Fasteners (includes illus. nos. 1 and 5 through 9)
2	800448	1	12-1/2" Stainless Steel Main Door Hinge Assembly
3	150410	4	#10-24 x 3/8" Phillips Pan Head Taptite Screw
4	152014	4	1/4-20 Free Spin Wash Nut
5	102349	1	Main Door Gasket
6	102212*	1	20-7/16" Door Glass with Four (4) Holes
	102210	1	20-7/16" Door Glass...Not Illustrated (for models mfd. prior to August 23, 1996)
	170730	1	Main Door Gasket/Glass Adhesive (10.3 oz. cartridge)
7	170319*	4	1/2" Stainless Steel Flat Head Allen Screw
8	150448*	4	Door Glass (nylon) Spacer
9	150431	1	Main Door Latch Screw (#10 x 7/16" dome hex head screw)

* For use on models mfd. with gray/black plastic main door assembly with mechanical fasteners ONLY.

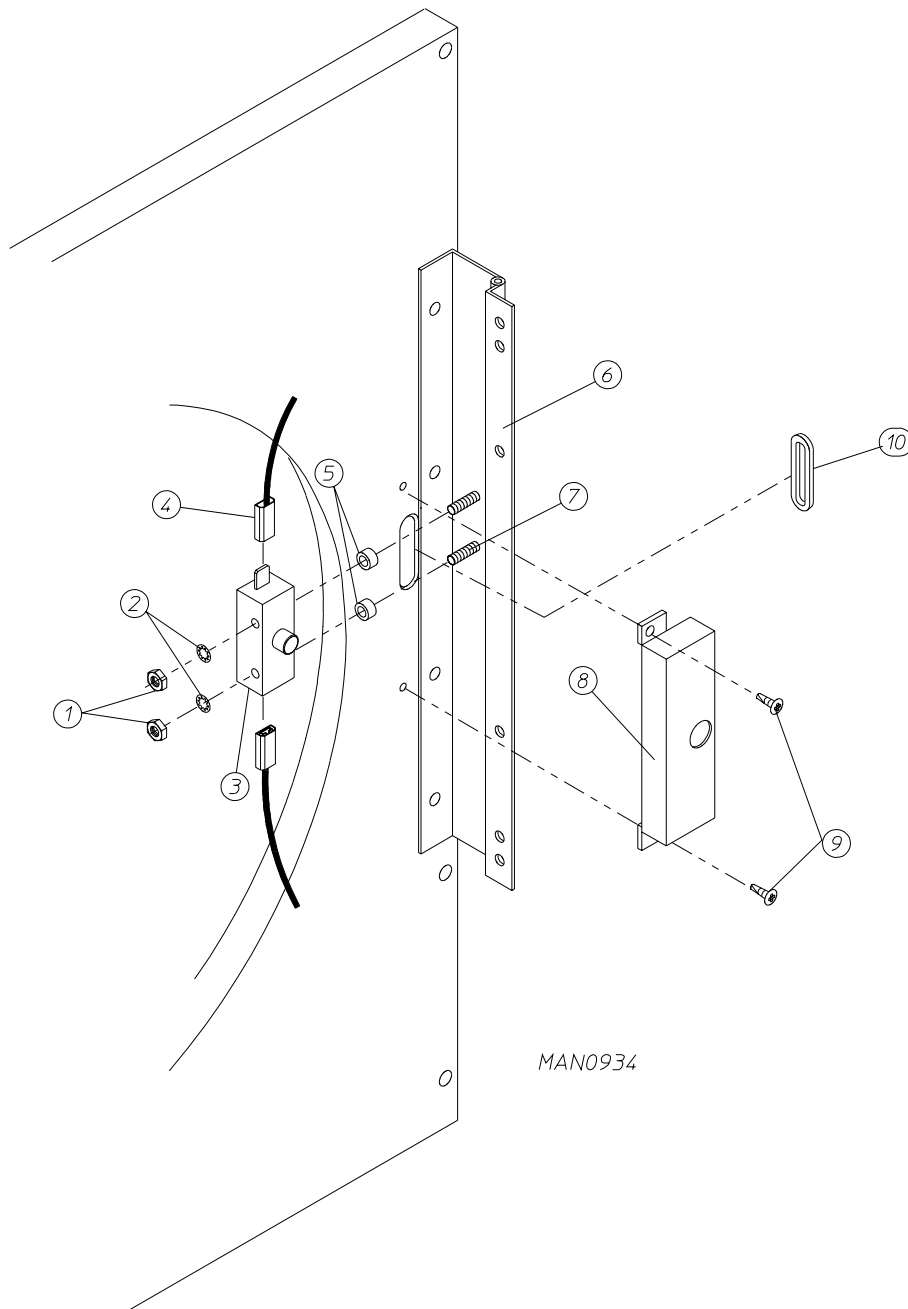

<u>Illus. No.</u>	<u>Part No.</u>	<u>Qty.</u>	<u>Description</u>
1	152013	2	#6-32 Hex Nut
2	153008	2	#6 Lock Washer
3	137005	1	Single-Pole Door Switch (SDS)
4	121028	2	Insulated Female Terminal
5	154281	2	3/8" Standard Nylon Spacer
6	800448	1	12-1/2" Stainless Steel Main Door Hinge Assembly (includes illus. nos. 6 and 7)
7	153565	2	#6 Stud
8	313218	1	Main Door Switch Housing
9	150201	2	#10-32 x 1/4" Phillips Pan Head Screw
10	121405	1	Rubber Grommet

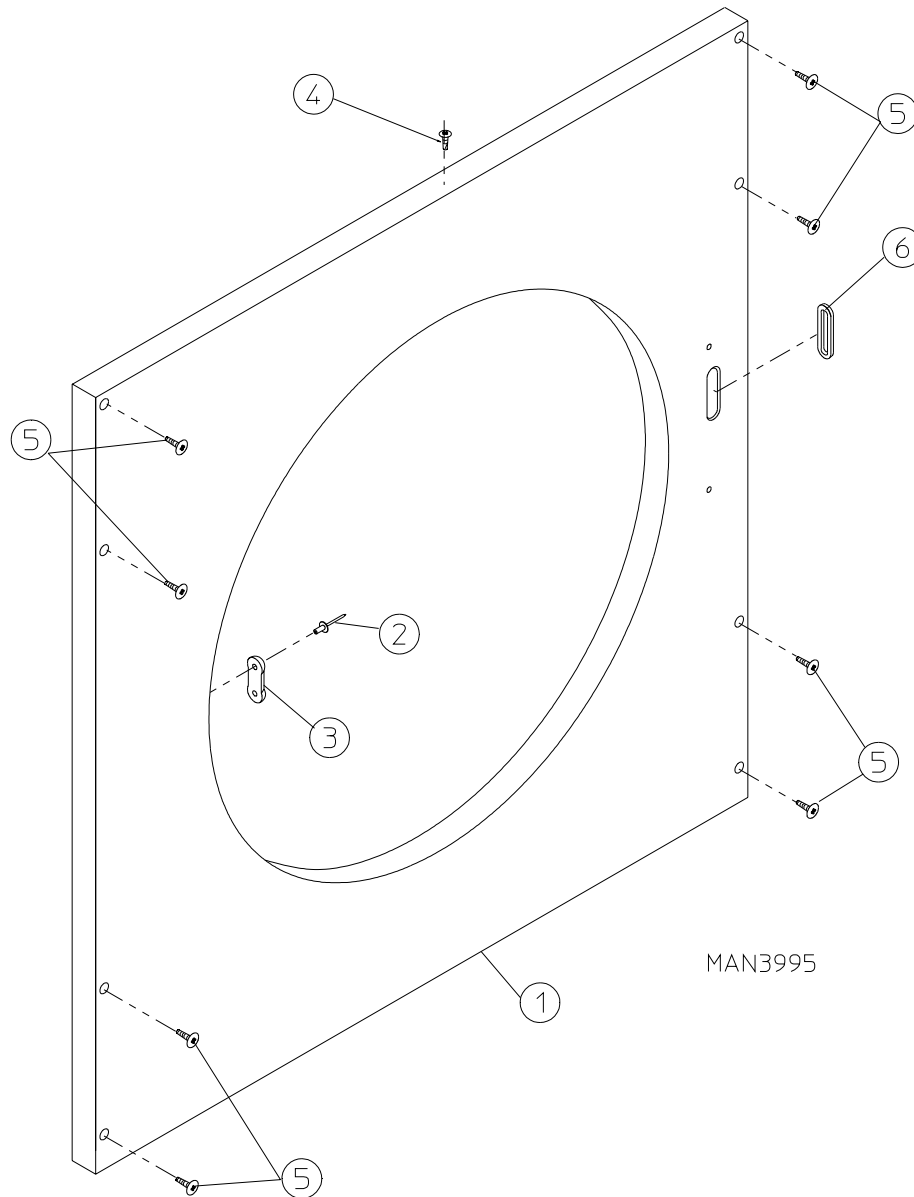

Illus. No.	Part No.	Qty.	Description
1	875300*	1	AD-30 Right Hand Insulated Front Panel Assembly Complete (latch-type) (includes illus. nos. 1, 2, 3, and 6)
	875311	1	AD-30 Stainless Steel Right Hand Insulated Front Panel Assembly Complete (latch-type) (includes illus. nos. 1, 2, 3, and 6)
2	154215	2	1/8" Pop Rivet
3	170330	1	Friction Door Latch
4	150300	1	#10-16 x 1/2" Hex Washer TEK Screw
5	150309	8	#10-16 x 1/2" Hex Head TEK Crimptite Screw
	150313	8	TORX Head Screw (for models mfd. as of October 2, 2000)
6	121405	1	Rubber Grommet

* Specify color when ordering.

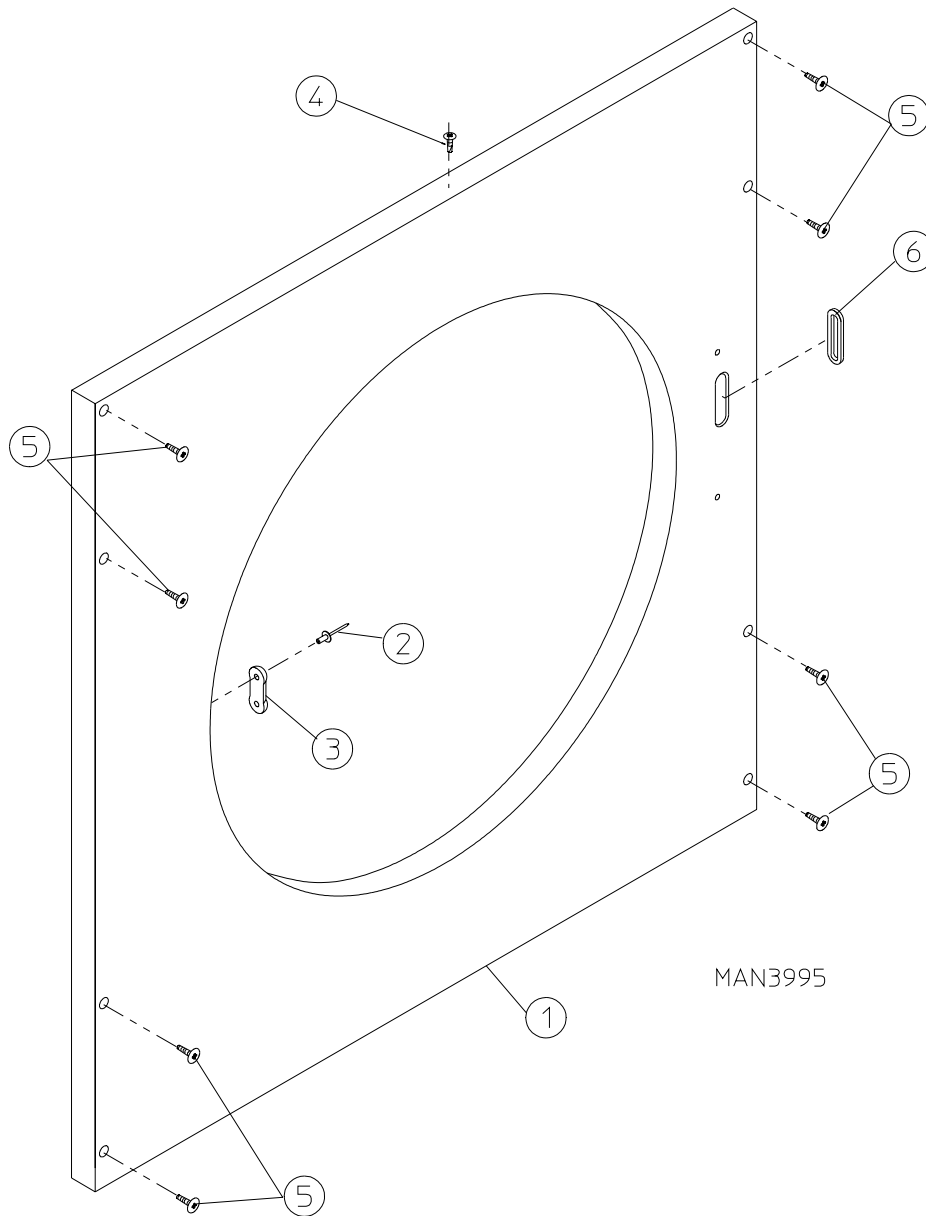

Illus. No.	Part No.	Qty.	Description
1	875301*	1	AD-50 Right Hand Insulated Front Panel Assembly Complete (latch-type) (includes illus. nos. 1, 2, 3, and 6)
	875312	1	AD-50 Stainless Steel Right Hand Insulated Front Panel Assembly Complete (latch-type) (includes illus. nos. 1, 2, 3, and 6)
2	154215	2	1/8" Pop Rivet
3	170330	1	Friction Door Latch
4	150300	1	#10-16 x 1/2" Hex Washer TEK Screw
5	150309	8	#10-16 x 1/2" Hex Head TEK Crimpite Screw
	150313	8	TORX Head Screw (for models mfd. as of October 2, 2000)
6	121405	1	Rubber Grommet

* Specify color when ordering.

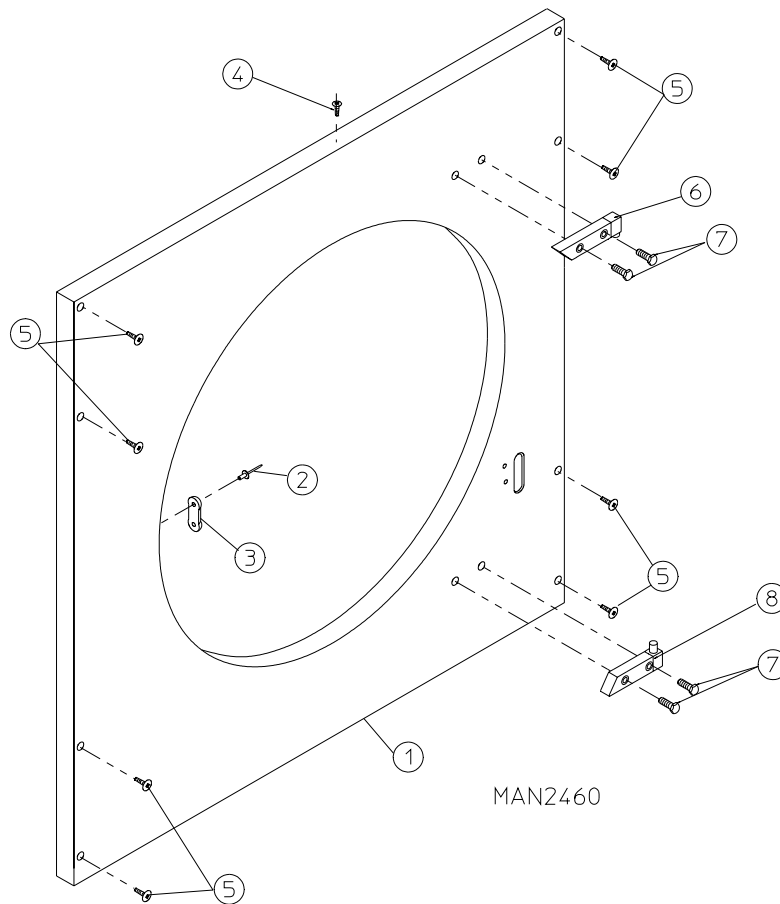

Illus. No.	Part No.	Qty.	Description
1	881268*	1	AD-30 Front Panel Assembly (cold rolled steel [CRS] door) (includes illus. nos. 1 through 3)
	881269*	1	AD-30 Front Panel Assembly Textured (cold rolled steel [CRS] door) (includes illus. nos. 1 through 3)
	881287	1	AD-30 Stainless Steel Front Panel Assembly (cold rolled steel [CRS] door) (includes illus. nos. 1 through 3)
	881793*	1	AD-30 Left Hand Front Panel Assembly (cold rolled steel [CRS] door) (includes illus. nos. 1 through 3)
	881964*	1	AD-30 Left Hand Front Panel Assembly Textured (cold rolled steel [CRS] door) (includes illus. nos. 1 through 3)
2	154215	2	1/8" Pop Rivet
3	170330	1	Friction Door Latch
4	150300	1	#10-16 x 1/2" Hex Washer TEK Screw
5	150309	8	#10-16 x 1/2" Phillips Hex Head CrimpTite Screw
6	881152	1	Black Top Hinge Block Assembly
	881208	1	Stainless Steel Top Hinge Block Assembly
7	150445	4	1/4-20 x 7/8" Black Cap Head Setscrew
	150443	4	1/4-20 x 7/8" Stainless Steel Cap Head Setscrew
8	881151	1	Black Bottom Hinge Block Assembly
	881209	1	Stainless Steel Bottom Hinge Block Assembly

* Specify color when ordering.

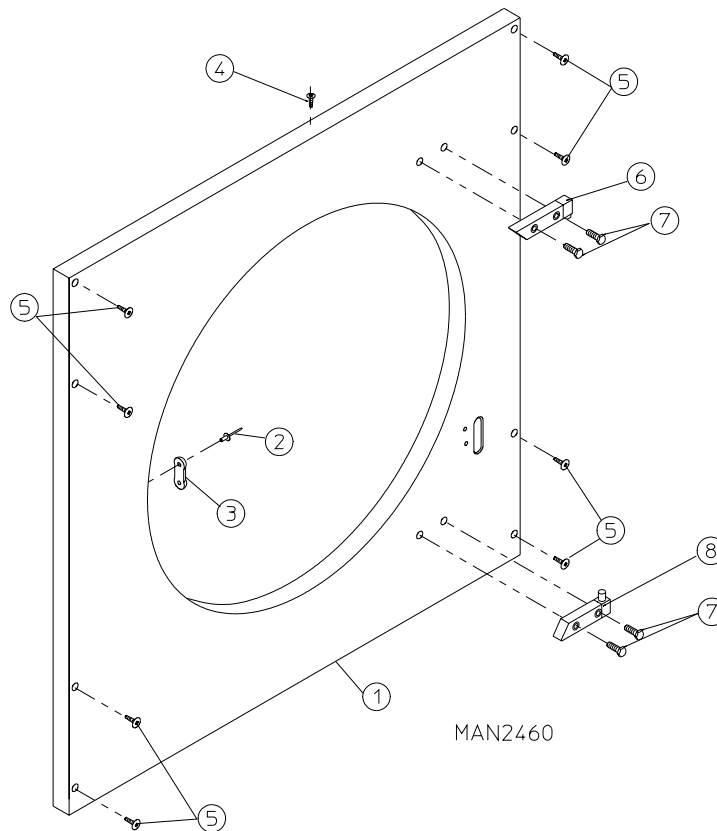

<u>Illus. No.</u>	<u>Part No.</u>	<u>Qty.</u>	<u>Description</u>
1	881270*	1	AD-50 Front Panel Assembly (cold rolled steel [CRS] door) (includes illus. nos. 1 through 3)
	881271*	1	AD-50 Front Panel Assembly Textured (cold rolled steel [CRS] door) (includes illus. nos. 1 through 3)
	881288	1	AD-50 Stainless Steel Front Panel Assembly (cold rolled steel [CRS] door) (includes illus. nos. 1 through 3)
	881996*	1	Left Hand Front Panel Assembly (cold rolled steel [CRS] door) (includes illus. nos. 1 through 3)
	882005*	1	AD-50 Left Hand Front Panel Assembly with Emergency Stop (cold rolled steel [CRS] door) (includes illus. nos. 1 through 3)
2	154215	2	1/8" Pop Rivet
3	170330	1	Friction Door Latch
4	150300	1	#10-16 x 1/2" Hex Washer TEK Screw
5	150309	8	#10-16 x 1/2" Phillips Hex Head TEK Crimptite Screw
	150313	8	TORX Head Screw (for models mfd. as of October 2, 2000)
6	881152	1	Black Top Hinge Block Assembly
	881208	1	Stainless Steel Top Hinge Block Assembly
7	150445	4	1/4-20 x 7/8" Black Cap Head Setscrew
	150443	4	1/4-20 x 7/8" Stainless Steel Cap Head Setscrew
8	881151	1	Black Bottom Hinge Block Assembly
	881209	1	Stainless Steel Bottom Hinge Assembly

* Specify color when ordering.

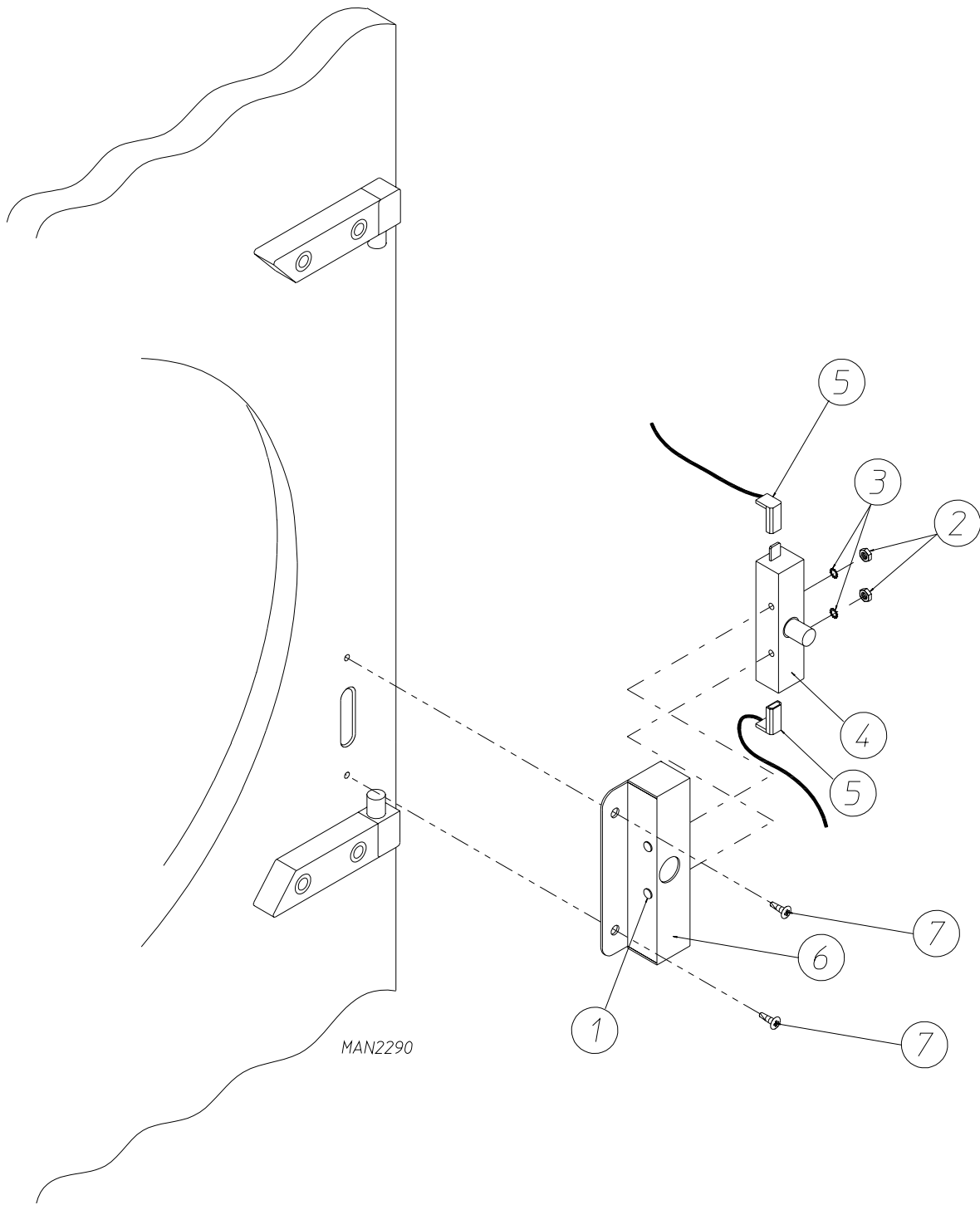

<u>Illus. No.</u>	<u>Part No.</u>	<u>Qty.</u>	<u>Description</u>
1	153566	2	#6-32 x 7/8" Clinch Stud
2	152013	2	#6-32 Hex Nut
3	153010	2	#6 Star Washer
4	137005	1	Single-Pole Door Switch (SDS)
5	122636	2	Flag Terminal
6	881211	1	Main Door Switch Housing
7	150301	2	#8-18 x 7/16" Phillips Pan Head TEK Screw

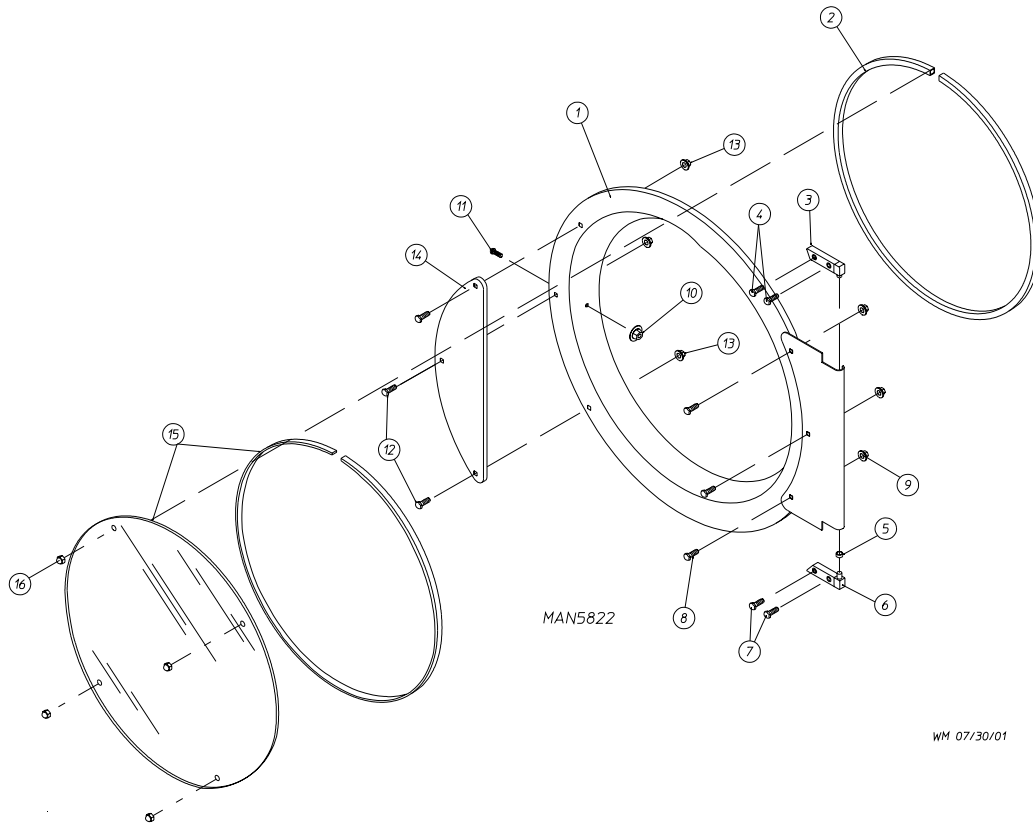

<u>Illus. No.</u>	<u>Part No.</u>	<u>Qty.</u>	<u>Description</u>
1	881150	1	Black Main Door Assembly Complete (includes illus. nos. 1, 2, and 8 through 15)
2	102354	1	Door Gasket
	170730	1	Clear Glass Adhesive (10.3 oz. cartridge)
	170731	1	Black Glass Adhesive (10.3 oz. cartridge)
3	881152	1	Black Top Hinge Block Assembly (includes illus. nos. 3 and 4)
4	150445	2	1/4-20 x 3/4" Black Cap Head Setscrew
5	153031	1	1/4" Nylon Washer
6	881151	1	Black Bottom Hinge Block Assembly (includes illus. nos. 5, 6, and 7)
7	150445	2	1/4-20 x 3/4" Black Cap Head Setscrew
	150443	2	1/4-20 x 3/4" Stainless Steel Cap Head Setscrew
8	150683	3	1/4-20 x 5/8" Black Carriage Bolt
9	152014	3	1/4-20 Free Spin Wash Nut
10	151010	1	#10-32 Black Hex Acorn Nut
11	150120	1	Door Latch Screw
12	150683	3	1/4-20 x 5/8" Black Carriage Bolt
13	152014	3	1/4-20 Free Spin Wash Nut
14	881210	1	Black Main Door Handle ONLY
15	102218	1	20-7/16" Door Glass with Four (4) Holes
	102211	1	Door Glass with Notch (for cold rolled steel [CRS] door without mechanical fasteners)
	170731	1	Black Glass Adhesive (10.3 oz. cartridge)
16	151013	4	#10-32 Black Nylon Acorn Nut

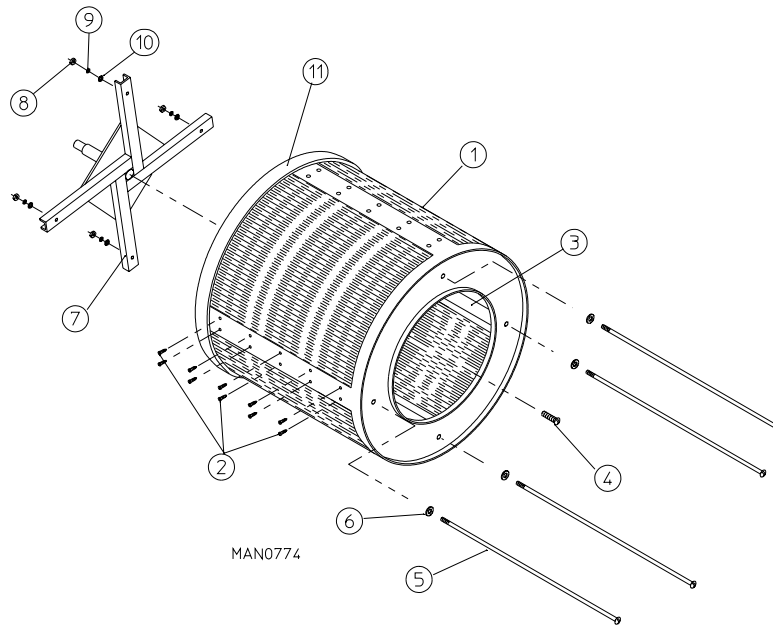

<u>Illus. No.</u>	<u>Part No.</u>	<u>Qty.</u>	<u>Description</u>
1*	800703	1	AD-30 Galvanized Basket (tumbler) ONLY (without felt collar)
	800803**	1	AD-30 Non-Reversing Galvanized Basket (tumbler) and Support Assembly (includes illus. nos. 1 through 10)
	800813**	1	AD-30 Reversing Galvanized Basket (tumbler) and Support Assembly (includes illus. nos. 1 through 10)
2	150413	40	#10-16 x 1/2" TORX Crimptite Screw
	150429	1	TORX Screw Hand Driver
3	301304	4	AD-30 Galvanized Basket (tumbler) Rib ONLY
4	115986	1	1/4" x 2" Felt Basket (tumbler) Pad (for models mfd. as of January 21, 2002)
	150518	1	5/16-18 x 3/8" Socket Button Head Screw (for models mfd. prior to January 21, 2002)
5	100902	4	5/16-18 x 31" Tie Rod
	150313	8	TORX Head Screw (for models mfd. as of October 2, 2000)
6	153001	4	5/16" Flat Washer
7	800603	1	AD-30 Non-Reversing Basket (tumbler) Support ONLY
	850049	1	AD-30 Reversing Basket (tumbler) Support ONLY
	100724	1	Key...Not Illustrated (for models mfd. as of July 1, 2001)
	100713	1	Key...Not Illustrated (for models mfd. prior to July 1, 2001)
8	152004	4	5/16-18 Hex Nut
9	153002	4	5/16" Lock Washer
10	153001	4	5/16" Flat Washer
11	116002	1	Felt Collar ONLY
--	401010	1	#847 Adhesive for Felt Collar (5.0 oz. tube)

* For stainless steel basket (tumbler), contact the factory.

** Felt collar *is not included* and **must be** ordered separately.

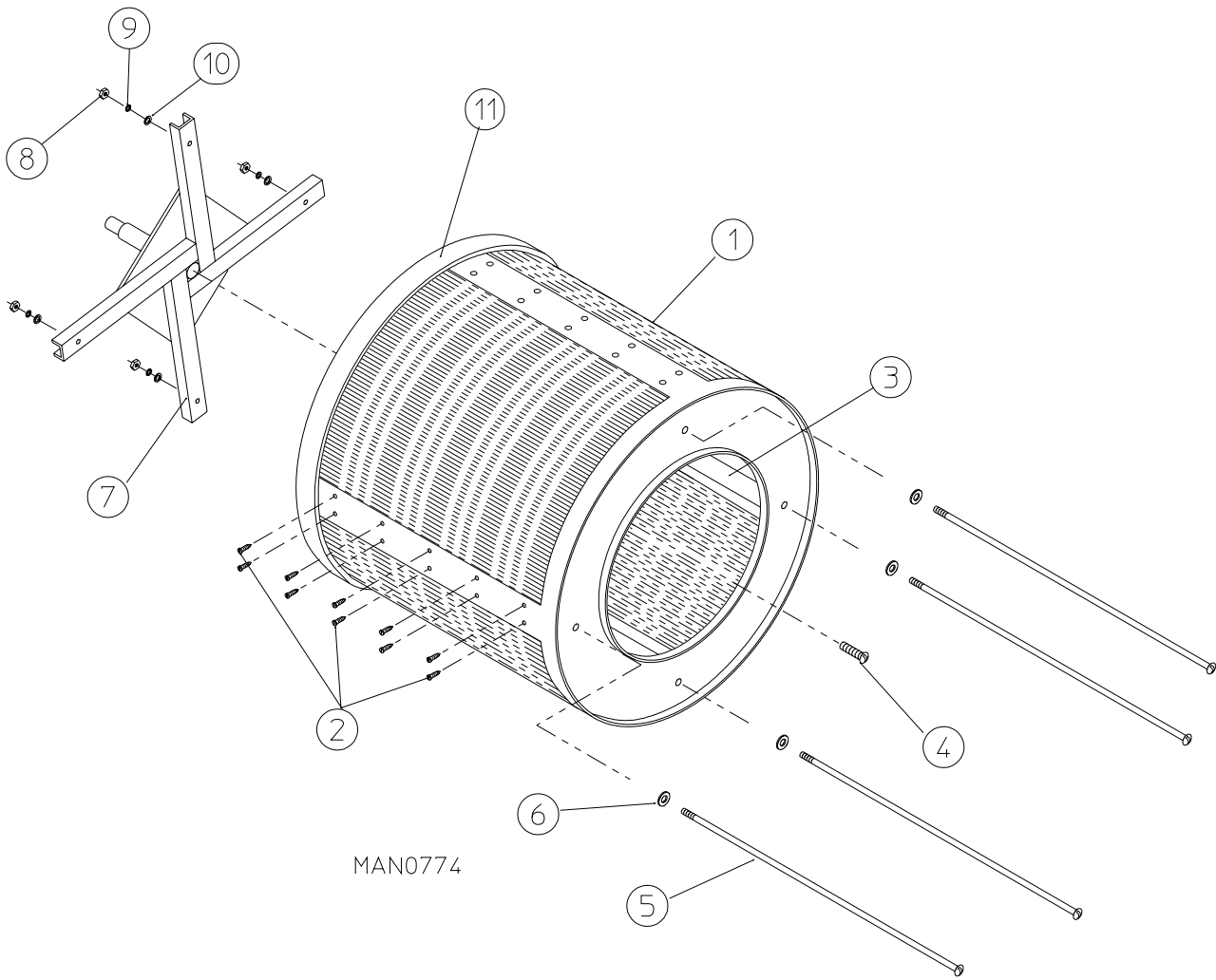

MAN0774

<u>Illus. No.</u>	<u>Part No.</u>	<u>Qty.</u>	<u>Description</u>
1*	800838	1	AD-50 Galvanized Basket (tumbler) ONLY (without felt collar)
	800837**	1	AD-50 Non-Reversing Galvanized Basket (tumbler) and Support Assembly with Tapered Ribs (includes illus. nos. 1 through 10)
	800839**	1	AD-50 Reversing Galvanized Basket (tumbler) and Support Assembly with Tapered Ribs (includes illus. nos. 1 through 10)
2	150413	40	#10-16 x 1/2" TORX Crimptite Screw
	150429	1	TORX Screw Hand Driver
3	301302	2	AD-50 Basket (tumbler) Rib ONLY (low rib)
	301311	2	AD-50 Tapered Basket (tumbler) Baffle Rib ONLY (high rib)
4	115986	1	1/4" x 2" Felt Basket (tumbler) Pad (for models mfd. as of January 21, 2002)
	150500	1	5/16-18 x 3/4" Socket Button Head Screw (for models mfd. prior to January 21, 2002)
5	100903	4	3/8-16 x 38-1/2" Tie Rod
6	153004	4	3/8" Flat Washer
7	800616	1	AD-50 Non-Reversing Basket (tumbler) Support ONLY
	800614	1	AD-50 Reversing Basket (tumbler) Support ONLY
	100724	1	Key...Not Illustrated (for models mfd. as of July 1, 2001)
	100713	1	Key...Not Illustrated (for models mfd. prior to July 1, 2001)
8	152005	4	3/8-16 Hex Nut
9	153005	4	3/8" Lock Washer
10	153004	4	3/8" Flat Washer
11	116001	1	Felt Collar ONLY
--	401010	1	#847 Adhesive for Felt Collar (5.0 oz. tube)

* For stainless steel basket (tumbler), contact the factory.

** Felt collar *is not included* and **must be** ordered separately.

For Models Mfd. as of October 19, 2002

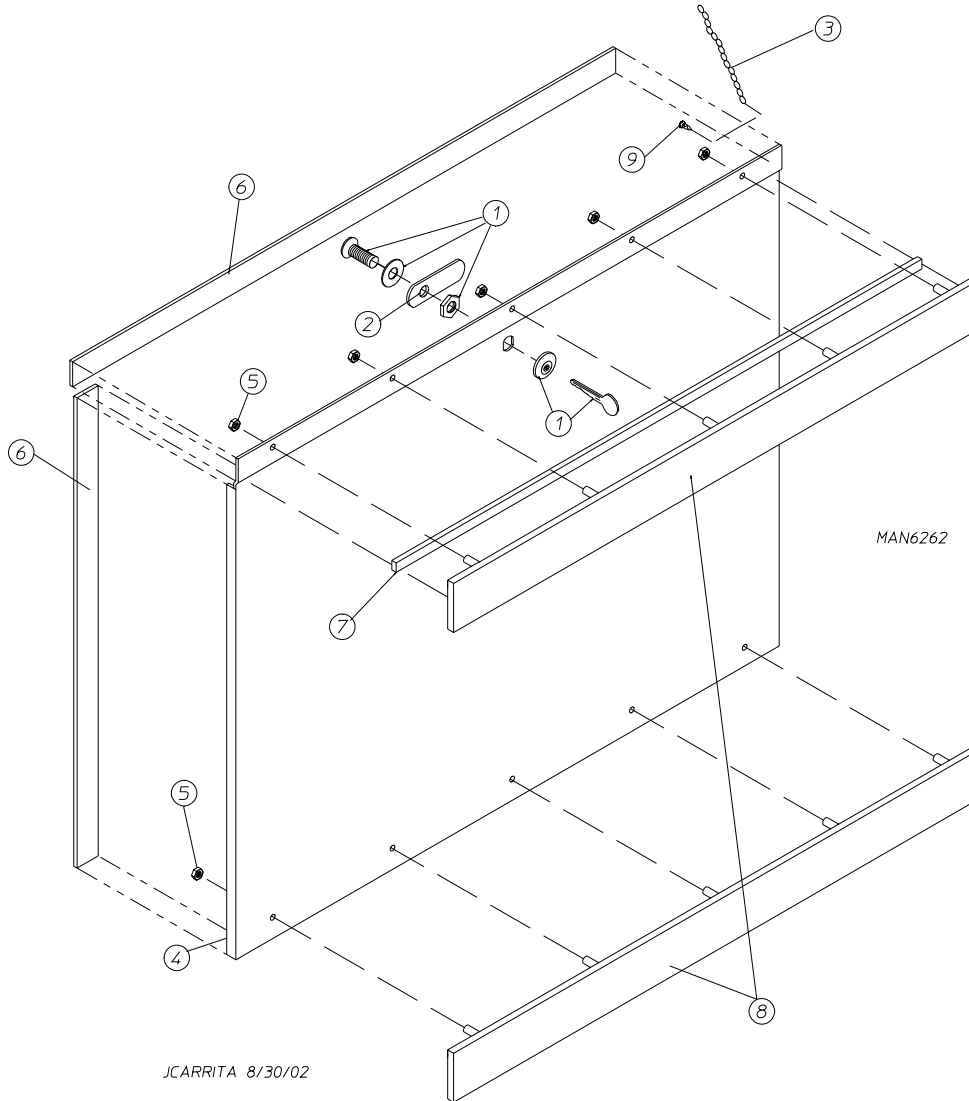

<u>Illus. No.</u>	<u>Part No.</u>	<u>Qty.</u>	<u>Description</u>
1	160001	1	AD-100 Lock Assembly with Key (for coin models Only)
	160103	1	AD-100 Key ONLY
2	160008	1	Lock Cam for AD-100 Lock and Dummy Lock
3	108120	1	Chain for Drop Lint Door
4	883533	1	White Drop Lint Door Assembly (includes illus. nos. 4 through 8)
	883648	1	Coral Blue Drop Lint Door Assembly (includes illus. nos. 4 through 8)
	883425	1	Ivory Drop Lint Door Assembly (includes illus. nos. 4 through 8)
5	152014	10	1/4-20 Free Spin Wash Nut
6	117604	7	Neoprene Sponge Tape (sold by the foot)
7	117603	3	Noise Suppressor Tape (sold by the foot)
8	883531	2	Black Trim/Kick Plate
9	150419	2	#6 x 1/2" Tamperproof TEK Screw
	150418	1	Tamperproof Screw Hand Driver

For OPL (Non-Coin) Models Mfd. between July 19, 1999 and October 19, 2002

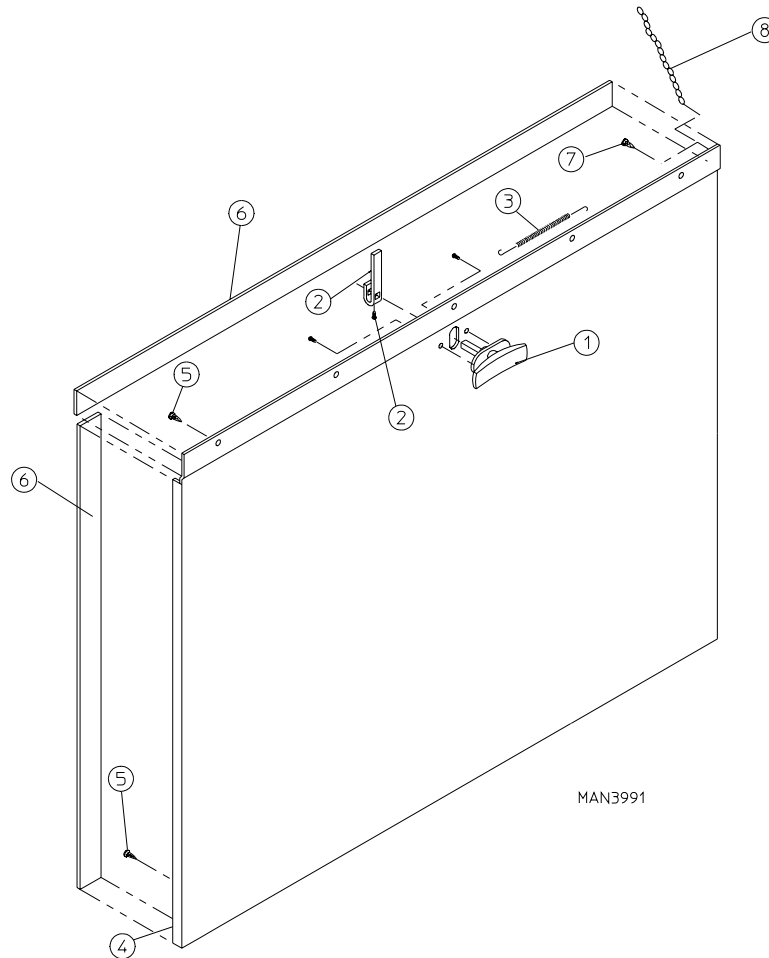

<u>Illus. No.</u>	<u>Part No.</u>	<u>Qty.</u>	<u>Description</u>
1	800150	1	Knob Latch Kit Assembly (includes illus. nos. 1 and 2)
	160003	1	Dummy Lock ONLY (for non-coin models)
	160104	1	MK-100 Key ONLY (for dummy lock)
2	160008	1	Lock Cam for AD-100 and Dummy Lock
	160009	1	Knob Latch Adjustable Cam ONLY
	150425	1	#12-24 x 3/8" Round Head Machine Screw ONLY (screw for knob latch adjustable cam)
3	157000	1	Drop Lint Door Spring
4	883098*	1	Insulated Drop Lint Door Assembly (includes illus. nos. 4 through 8)
	-----	1	Stainless Steel Insulated Drop Lint Drawer Assembly (includes illus. nos. 4 through 8)
5	150201	6	#10-32 x 1/4" Phillips Pan Head TEK Screw
6	117604	7	Neoprene Sponge Tape (sold by the foot)
7	150419	2	#6 x 1/2" Tamperproof TEK Screw
8	108120	1	Chain for Drop Lint Door (10-1/2" length)
--	150418	1	Tamperproof Screw Hand Driver

* Specify color when ordering.

For Coin and OPL Models Mfd. prior to July 19, 1999

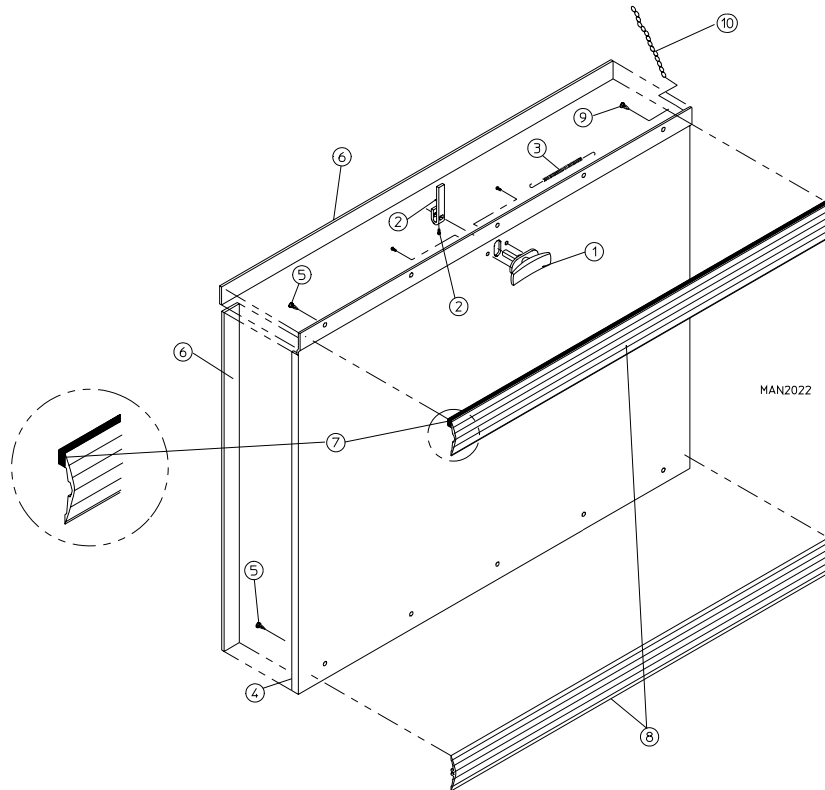

<u>Illus. No.</u>	<u>Part No.</u>	<u>Qty.</u>	<u>Description</u>
1	160001	1	AD-100 Lock Assembly with Key (for coin models Only)
	160103	1	AD-100 Key ONLY
	800150	1	Knob Latch Kit Assembly (for non-coin models Only)
	160200	1	Knob Latch ONLY with Two (2) Screws (for non-coin models Only)
	160003	1	Dummy Lock ONLY (for non-coin models Only)
2	160104	1	MK-100 Key ONLY (master key)
	160008	1	Lock Cam for AD-100 Lock and Dummy Lock
	160009	1	Knob Latch Adjustable Cam (for non-coin models Only)
3	150425	1	#12-24 x 3/8" Phillips Round Head Machine Screw (for knob latch adjustable cam)
	157000	1	Drop Lint Door Spring
	800216*	1	AD-30 Drop Lint Door Assembly (includes illus. nos. 4 through 8)
4	800233*	1	AD-30 Insulated Drop Lint Door Assembly (includes illus. nos. 4 through 8)
	800240	1	AD-30 Stainless Steel Drop Lint Door Assembly
	150201	10	#10-32 x 1/4" Phillips Pan Head Machine Screw
5	117604	7	Neoprene Sponge Tape (sold by the foot)
6	117603	3	Noise Suppressor Tape (sold by the foot)
7	180210	2	AD-30 Trim/Kick Plate (31-1/8" length)
8	150419	2	#6 x 1/2" Tamperproof TEK Screw
	150418	1	Tamperproof Screw Hand Driver
9	108120	1	Chain for Drop Lint Door

* Specify color when ordering.

For Models Mfd. as of October 7, 2002

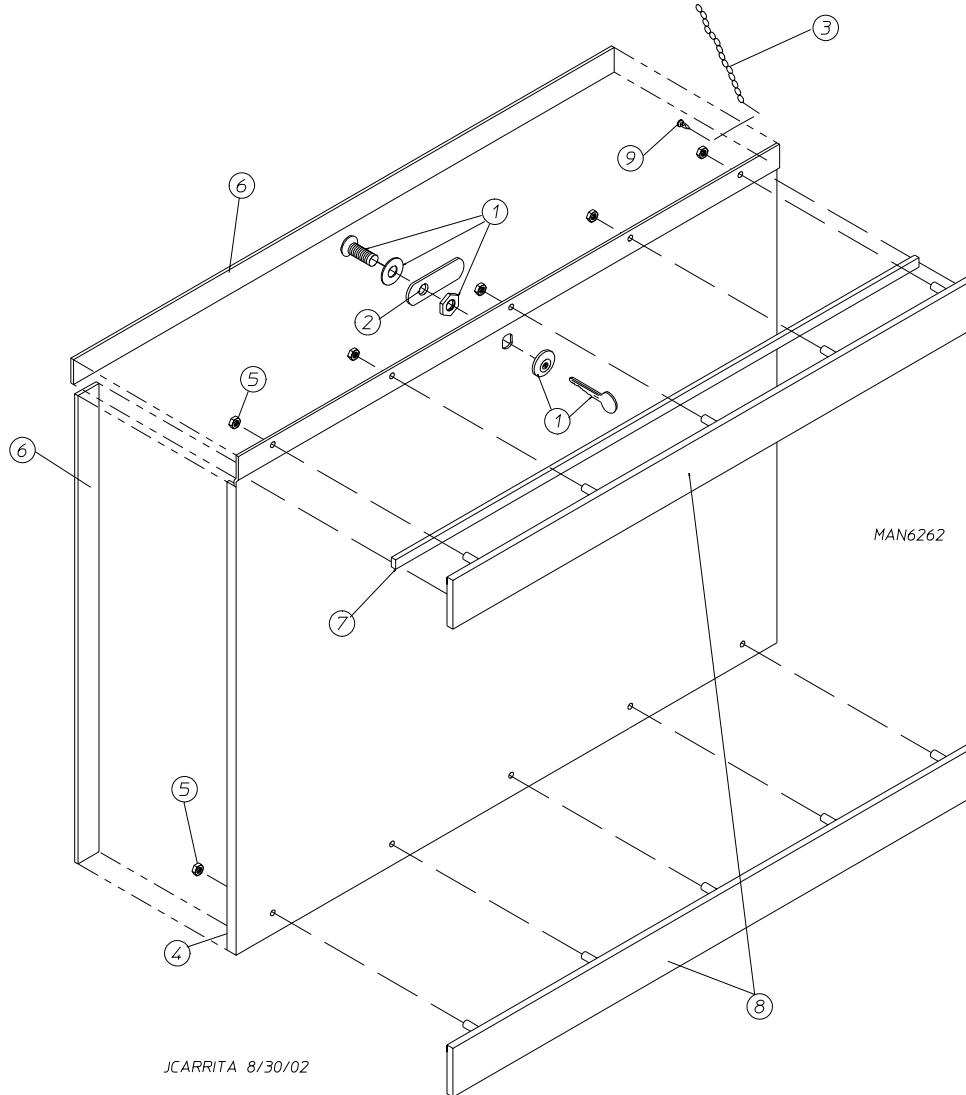

Illus. No.	Part No.	Qty.	Description
1	160001	1	AD-100 Lock Assembly with Key (for coin models Only)
	160103	1	AD-100 Key ONLY
2	160008	1	Lock Cam for AD-100 Lock and Dummy Lock
3	108120	1	Chain for Drop Lint Door
4	883649	1	White Drop Lint Door Assembly (includes illus. nos. 4 through 8)
	883650	1	Coral Blue Drop Lint Door Assembly (includes illus. nos. 4 through 8)
	883651	1	Ivory Drop Lint Door Assembly (includes illus. nos. 4 through 8)
5	152014	10	1/4-20 Free Spin Wash Nut
6	117604	7	Neoprene Sponge Tape (sold by the foot)
7	117603	3	Noise Suppressor Tape (sold by the foot)
8	883624	2	Black Trim/Kick Plate
9	150419	2	#6 x 1/2" Tamperproof TEK Screw
	150418	1	Tamperproof Screw Hand Driver

For OPL (Non-Coin) Models Mfd. between November 28, 1999 and October 7, 2002

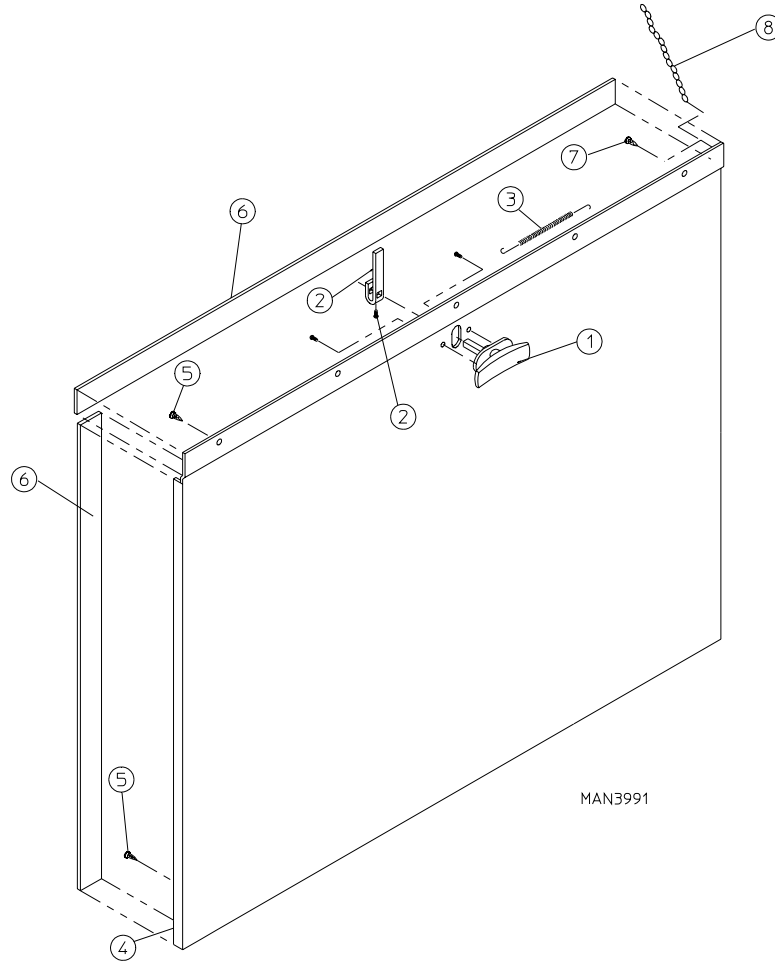

<u>Illus. No.</u>	<u>Part No.</u>	<u>Qty.</u>	<u>Description</u>
1	800150	1	Knob Latch Kit Assembly (includes illus. nos. 1 and 2)
	160003	1	Dummy Lock ONLY (for non-coin models)
	160104	1	MK-100 Key ONLY (for dummy lock)
2	160008	1	Lock Cam for AD-100 and Dummy Lock
	160009	1	Knob Latch Adjustable Cam ONLY
	150425	1	#12-24 x 3/8" Round Head Machine Screw ONLY (screw for knob latch adjustable cam)
3	157000	1	Drop Lint Door Spring
4	882264*	1	Insulated Drop Lint Door Assembly (includes illus. nos. 4 through 8)
	-----	1	Stainless Steel Insulated Drop Lint Drawer Assembly (includes illus. nos. 4 through 8)
5	150201	6	#10-32 x 1/4" Phillips Pan Head TEK Screw
6	117604	7	Neoprene Sponge Tape (sold by the foot)
7	150419	2	#6 x 1/2" Tamperproof TEK Screw
8	108120	1	Chain for Drop Lint Door (10-1/2" length)
-	150418	1	Tamperproof Screw Hand Driver

* Specify color when ordering.

For Coin and OPL Models Mfd. prior to November 28, 1998

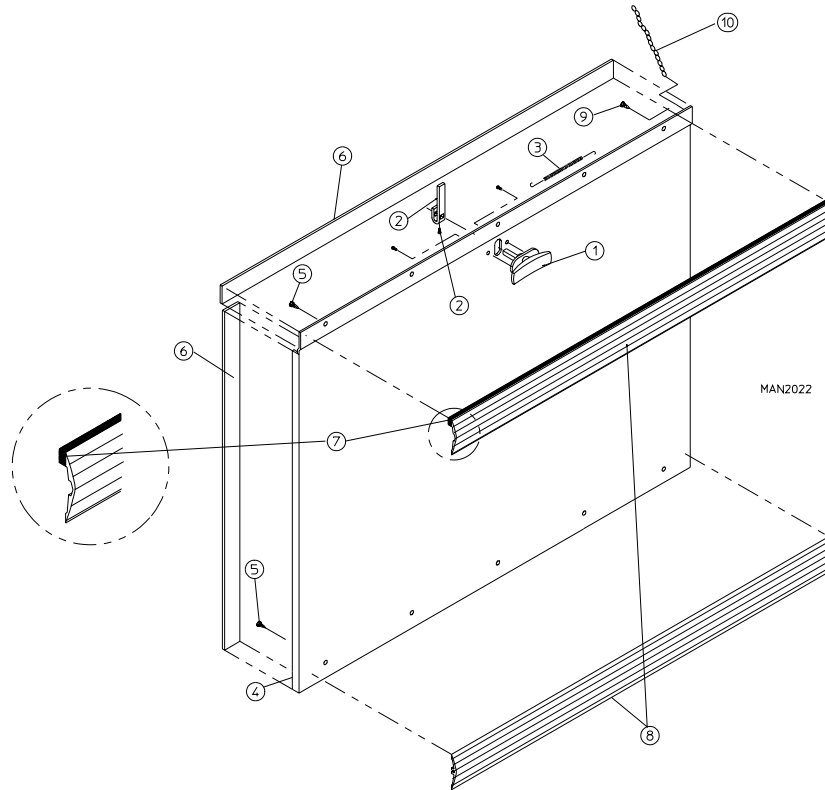

Illus. No.	Part No.	Qty.	Description
1	160001	1	AD-100 Lock Assembly with Key (for coin models Only)
	160103	1	AD-100 Key ONLY
	800150	1	Knob Latch Kit Assembly (for non-coin models Only)
	160200	1	Knob Latch ONLY with Two (2) Screws (for non-coin models Only)
	160003	1	Dummy Lock ONLY (for non-coin models Only)
	160104	1	MK-100 Key ONLY (master key)
2	160008	1	Lock Cam for AD-100 Lock and Dummy Lock
	160009	1	Knob Latch Adjustable Cam (for non-coin models Only)
	150425	1	#12-24 x 3/8" Phillips Round Head Machine Screw (for knob latch adjustable cam)
3	157000	1	Drop Lint Door Spring
4	800219*	1	AD-50 Drop Lint Door Assembly (includes illus. nos. 4 through 8)
	800232*	1	AD-50 Insulated Drop Lint Door Assembly (includes illus. nos. 4 through 8)
	800243	1	AD-50 Stainless Steel Drop Lint Door Assembly
5	150201	10	#10-32 x 1/4" Phillips Pan Head Machine Screw
6	117604	7	Neoprene Sponge Tape (sold by the foot)
7	117603	3	Noise Suppressor Tape (sold by the foot)
8	180211	2	AD-50 Trim/Kick Plate (31-1/8" length)
9	150419	2	#6 x 1/2" Tamperproof TEK Screw
	150418	1	Tamperproof Screw Hand Driver
10	108120	1	Chain for Drop Lint Door

* Specify color when ordering.

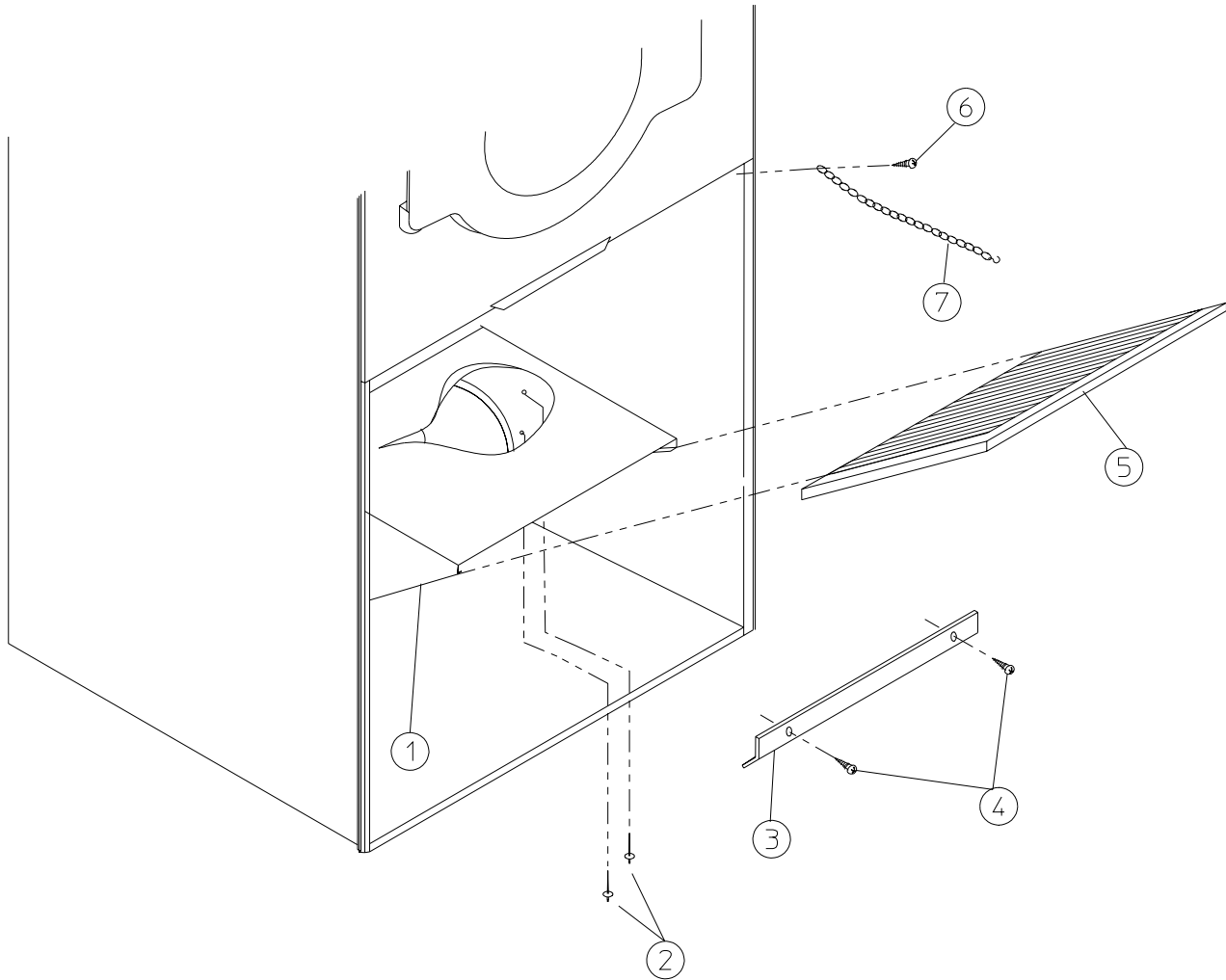

MAN0107

<u>Illus. No.</u>	<u>Part No.</u>	<u>Qty.</u>	<u>Description</u>
1	800408	1	AD-30 Non-Reversing Lint Trap Assembly Complete (includes illus. nos. 1, 3, 4, and 5)
	800409	1	AD-30 Lint Trap ONLY
2	154200	7	5/32" Pop Rivet
3	304102	1	AD-30 Lint Screen Holder ONLY
4	150300	3	#10-16 x 1/2" Hex Washer TEK Screw
5	800503	1	AD-30 Lint Screen ONLY
6	150419	2	#6 x 1/2" Tamperproof TEK Screw
7	108120	1	Chain for Drop Lint Door (10-1/2" length)
--	150418	1	Tamperproof Screw Hand Driver

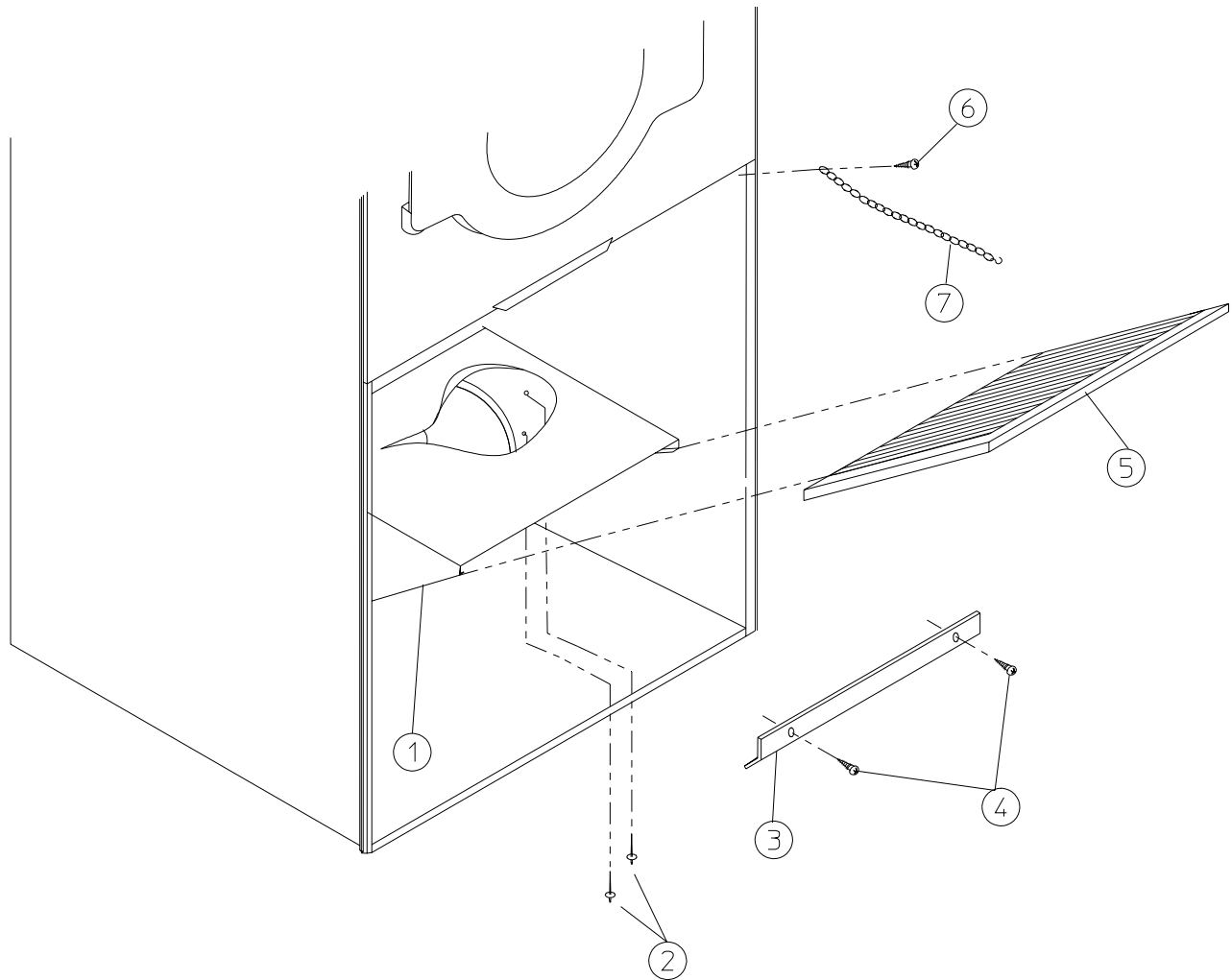

MAN0107

<u>Illus. No.</u>	<u>Part No.</u>	<u>Qty.</u>	<u>Description</u>
1	800402	1	AD-50 Lint Trap Assembly Complete (includes illus. nos. 1, 3, 4, and 5)
	800404	1	AD-50 Non-Reversing Lint Trap ONLY
	800407	1	AD-50 Reversing Lint Trap Assembly Complete (includes illus. nos. 1, 3, 4, and 5)
	800406	1	AD-50 Reversing Lint Trap ONLY
2	154200	7	5/32" Pop Rivet
3	304101	1	AD-50 Lint Screen Holder ONLY
4	150300	3	#10-16 x 1/2" Hex Washer TEK Screw
5	800501	1	AD-50 Lint Screen ONLY
6	150419	2	#6 x 1/2" Tamperproof TEK Screw
7	108120	1	Chain for Drop Lint Door
--	150418	1	Tamperproof Screw Hand Driver

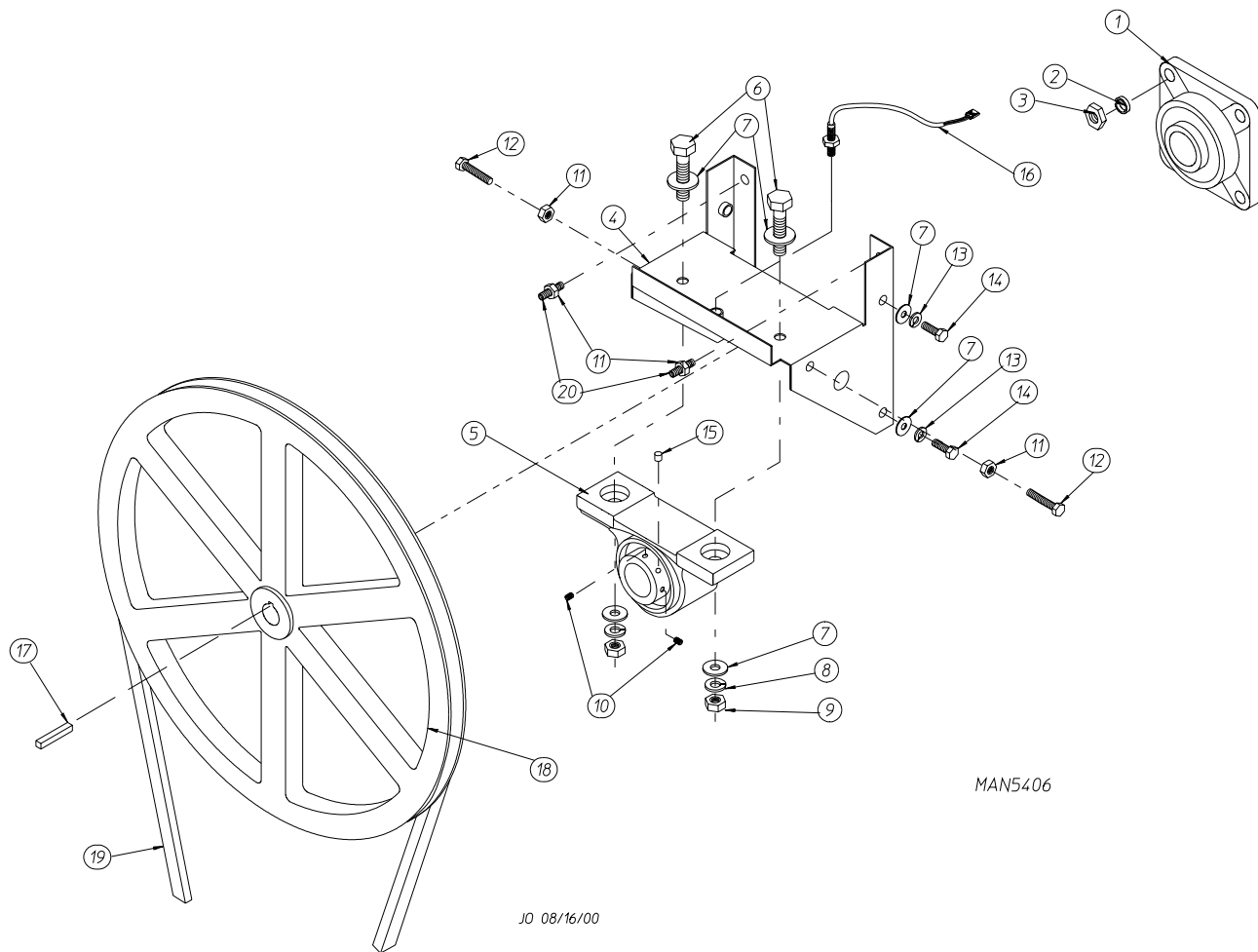

<u>Illus. No.</u>	<u>Part No.</u>	<u>Qty.</u>	<u>Description</u>
1	880203	1	1-3/8" Flange Bearing AD-30 ONLY
	880220	1	1-3/4" Flange Bearing AD-50 ONLY
2	153005	4	3/8" Lock Washer
3	152005	4	3/8-16 Hex Nut
4	882544	1	Pillow Block Bearing Assembly Complete (includes illus. nos. 4 through 14 and 20)
	882545	1	Bearing Assembly Complete with Rotational Sensor (includes illus. nos. 4 through 16 and 20)
	882542	1	Bearing Support ONLY
	882543	1	Bearing Support ONLY (with rotational sensor)
5	880202	1	1-3/8" Pillow Block Bearing ONLY
	880779	1	1-3/8" Pillow Block Bearing Assembly (with rotational sensor)
6	150601	2	3/8-16 x 2" Hex Bolt
7	153004	8	3/8" Flat Washer
8	153005	2	3/8" Lock Washer
9	152005	2	3/8-16 Hex Nut
10	154326	2	5/16-24 x 3/8" Setscrew (black)
11	152004	4	5/16-18 Hex Nut
12	150621	2	5/16-18 x 1-1/2" Tap Bolt
13	153002	4	5/16" Lock Washer
14	150501	4	5/16-18 x 3/4" Tap Bolt
15	102120	1	Sintered 8 Magnet
	401010	1	#847 Construction Mastic
16	824807	1	Rotational Sensor Assembly
17	100713	1	1/4" x 1/4" x 7/8" Key
18	101100	1	18" Pulley (for non-reversing models Only)
	101118	1	18-3/4" Pulley (for reversing models Only)
	101119	1	1-3/8" Taper Lock Hub Key...Not Illustrated (for reversing models Only)
	100735	1	Shaft Key (for taper lock hub)
19	100106	1	5L-690 V-Belt (for reversing models Only)
	100108	1	5L-680 V-Belt (for non-reversing models Only)
20	150610	2	5/16-18 x 1-1/2" Allen Setscrew

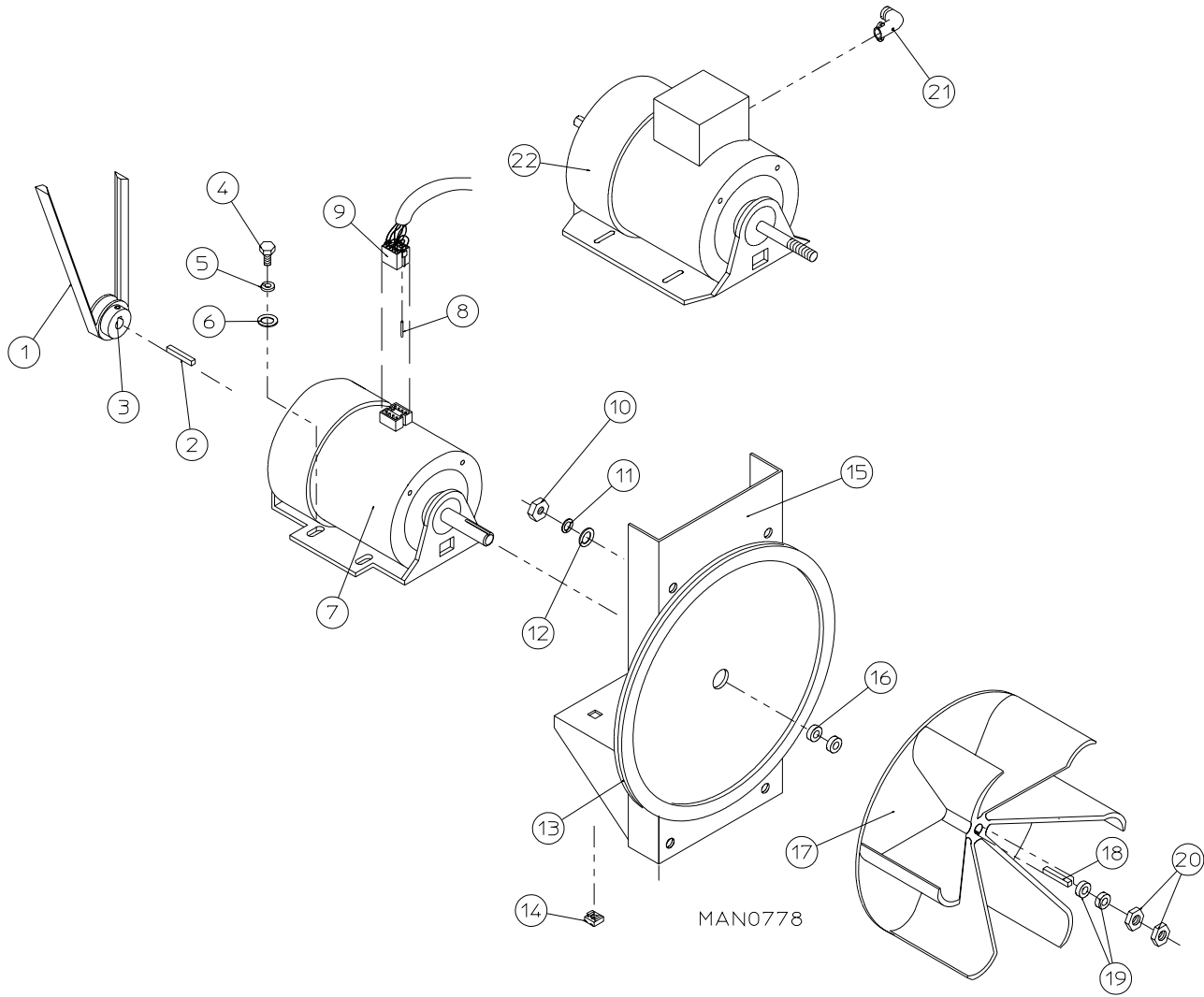

<u>Illus. No.</u>	<u>Part No.</u>	<u>Qty.</u>	<u>Description</u>
1	100110	1	4L-500 V-Belt (motor to idler)
2	100701	1	3/16" x 3/16" x 1" Key (for use on 3 ϕ - 60 Hz models Only)
3	101104	1	1/2" x 2" Motor Pulley (for use on 1 ϕ - 60 Hz models Only)
	101132	1	5/8" x 2" Motor Pulley (for use on 3 ϕ - 60 Hz models Only)
	101133	1	5/8" x 2-1/4" Motor Pulley (for use on 50 Hz motors Only)
4	150501	4	5/16-18 x 3/4" Hex Head Machine Bolt
5	153002	4	5/16" Lock Washer
6	153001	4	5/16" Flat Washer
7	100065	1	1/2 HP 100v 1 ϕ 50 Hz/120-230v 1 ϕ 60 Hz Totally Enclosed, Fan-Cooled (T.E.F.C.) Motor with Plug
	100066	1	1/2 HP 240v 1 ϕ 50 Hz Totally Enclosed, Fan-Cooled (T.E.F.C.) Motor with Plug
			(for models mfd. as of August 28, 1992)

<u>Illus. No.</u>	<u>Part No.</u>	<u>Qty.</u>	<u>Description</u>
8	122701	8	Socket Terminal ONLY
	122801	1	Pin/Socket Extraction Tool...Not Illustrated
9	137030	1	8-Pin Housing Connector
10	152004	4	5/16-18 Hex Nut
11	153002	4	5/16" Lock Washer
12	153001	4	5/16" Flat Washer
13	117604	4	Neoprene Sponge Tape (sold by the foot) (for models mfd. as of August 6, 1998)
	117600	4	Noise Suppressor Tape (sold by the foot) (for models mfd. as of August 6, 1998)
14	154000	4	5/16-18 Tinnerman Nut
15	800908	1	AD-30 Non-Reversing Motor Mount ONLY (56Z frame)
	803938*	1	1/2 HP 120-230v 1 ϕ 50/60 Hz Totally Enclosed, Fan-Cooled (T.E.F.C.) Motor Mount Assembly Complete with Plug Motor (includes illus. nos. 3 through 7 and 13 through 20) (for models mfd. as of August 28, 1992)
	803813	1	1/2 HP 240v 1 ϕ 50 Hz Non-Reversing Totally Enclosed, Fan-Cooled (T.E.F.C.) Motor Mount Assembly Complete with Plug Motor (includes illus. nos. 3 through 7 and 13 through 20) (for models mfd. as of August 28, 1992)
	803809*	1	1/2 HP 208/230/380/460v 3 ϕ 60 Hz Totally Enclosed, Fan-Cooled (T.E.F.C.) Motor Mount Assembly Complete (includes illus. nos. 2 through 6 and 13 through 22)
	803810*	1	1/2 HP 208/230/380/460v 3 ϕ 50 Hz Non-Reversing Totally Enclosed, Fan-Cooled (T.E.F.C.) Motor Mount Assembly Complete (includes illus. nos. 2 through 6 and 13 through 22)
	803808*	1	1/2 HP 240v 1 ϕ 50 Hz Totally Enclosed, Fan-Cooled (T.E.F.C.) Motor Mount Assembly Complete (includes illus. nos. 3 through 6 and 13 through 22) (for models mfd. prior to August 28, 1992)
16	153050	2	1/2" S.A.E. Flat Washer
17	100604	1	12-1/2" Impellor (fan/blower) with 1/2" Bore
18	100702	1	1/8" x 1/8" x 1-1/2" Key
19	153050	2	1/2" S.A.E. Flat Washer
20	152006	2	1/2-20 Left Hand Jam Nut
21	120200	1	3/8" x 90° Connector
22	100007*	1	1/2 HP 208/230/380/460v 1 ϕ 50/60 Hz Totally Enclosed, Fan-Cooled (T.E.F.C.) Motor (56Z frame)
	100035	1	1/2 HP 240v 1 ϕ 50 Hz Totally Enclosed, Fan-Cooled (T.E.F.C.) Motor (56Z frame) (for models mfd. prior to August 28, 1992)

* Specify voltage when ordering.

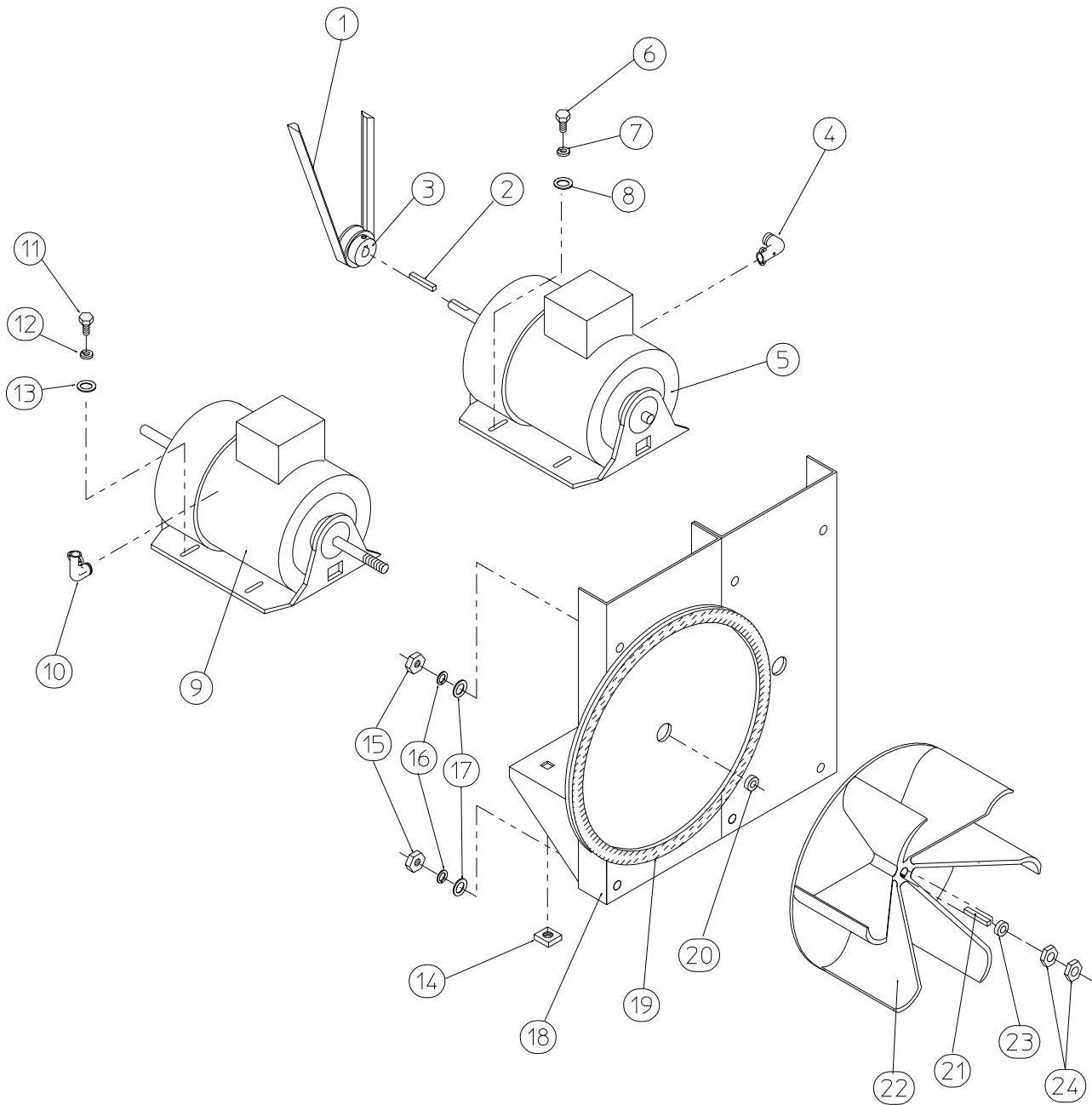

MAN1970

<u>Illus. No.</u>	<u>Part No.</u>	<u>Qty.</u>	<u>Description</u>
1	100117	1	4L-620 V-Belt (motor to idler)
2	100701	1	3/16" x 3/16" x 1" Key
3	101132	1	5/8" x 2" Motor Pulley (60 Hz Only)
	101133	1	5/8" x 2-1/4" Motor Pulley (50 Hz Only)
4	120200	1	3/8" x 90° Connector
5	181003	1	1/2 HP 208/230/380/460v 3ø 50/60 Hz Motor (56Z frame)
6	150501	4	5/16-18 x 3/4" Hex Head Machine Bolt
7	153002	4	5/16" Lock Washer
8	153001	4	5/16" Flat Washer
9	100007	1	1/2 HP 208/230/380/460v 3ø 50/60 Hz Totally Enclosed, Fan-Cooled (T.E.F.C.) Motor (56Z frame)
10	120200	1	3/8" x 90° Connector
11	150501	4	5/16-18 x 3/4" Hex Head Machine Bolt
12	153002	4	5/16" Lock Washer
13	153001	4	5/16" Flat Washer
14	154000	8	5/16" Tinnerman Nut
15	152004	4	5/16" Hex Nut
16	153002	4	5/16" Lock Washer
17	153001	4	5/16" Flat Washer
18	800918	1	AD-30 Reversing Motor Mount ONLY (56Z frame) (includes illus. nos. 18 and 19)
	803802*	1	AD-30 Reversing Totally Enclosed, Fan-Cooled (T.E.F.C.) Motor Mount Assembly Complete (for 60 Hz models Only) (includes illus. nos. 2 through 14 and 18 through 24)
	803803*	1	AD-30 Reversing Totally Enclosed, Fan-Cooled (T.E.F.C.) Motor Mount Assembly Complete (for 50 Hz models Only) (includes illus. nos. 2 through 14 and 18 through 24)
19	117604	4	Neoprene Sponge Tape (sold by the foot) (for models mfd. as of August 6, 1998)
	117600	4	Noise Suppressor Tape (sold by the foot) (for models mfd. as of August 6, 1998)
20	153050	2	1/2" S.A.E. Flat Washer
21	100702	1	1/8" x 1/8" x 1-1/2" Key
22	100604	1	12-1/2" Impellor (fan/blower) with 1/2" Bore
23	153050	2	1/2" S.A.E. Flat Washer
24	152006	2	1/2-20 Left Hand Jam Nut

* Specify voltage when ordering.

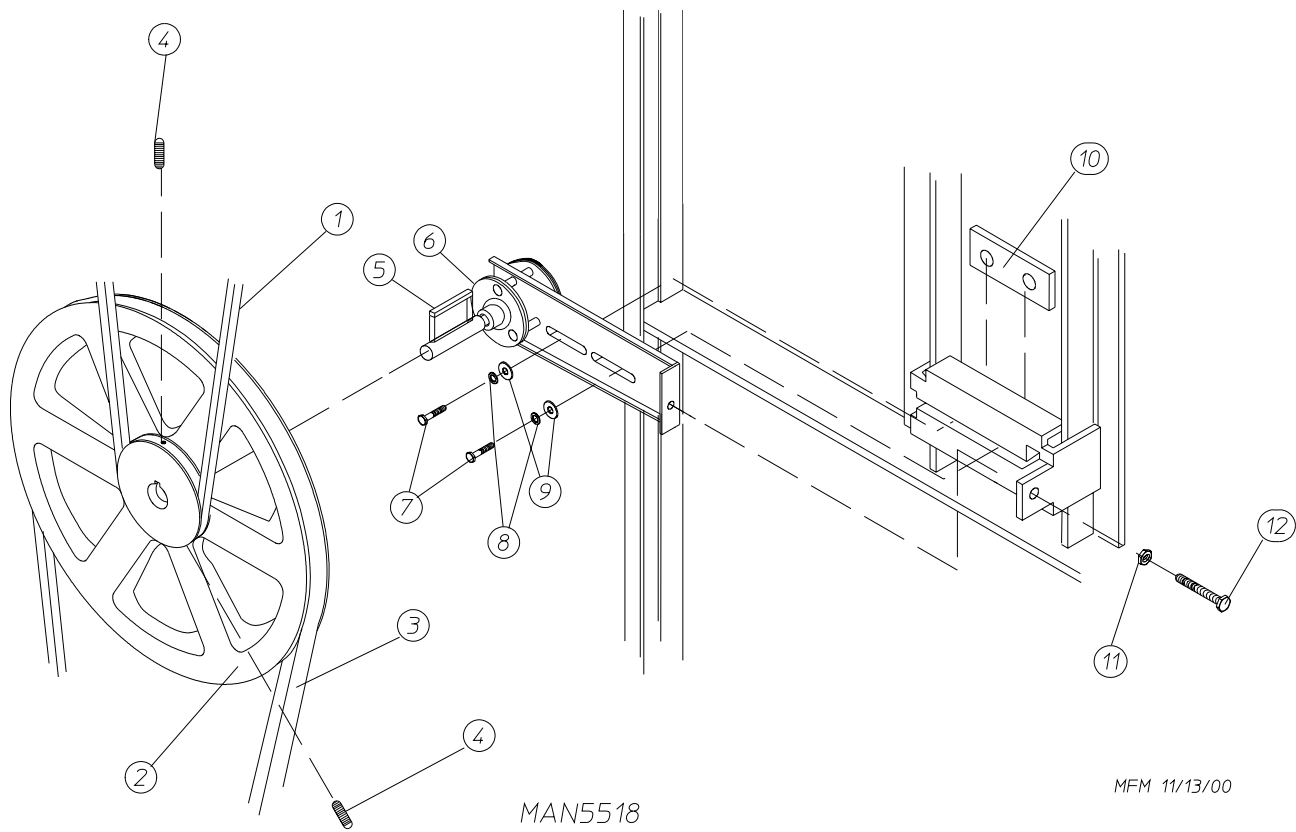

<u>Illus. No.</u>	<u>Part No.</u>	<u>Qty.</u>	<u>Description</u>
1	100108	1	5L-610 V-Belt (idler to basket [tumbler]) For Use on AD-30/AD-50
	100106	1	5L-690 V-Belt (idler to basket [tumbler]) For Reversing Models ONLY
2	101140	1	14" x 3" Compound Pulley (for AD-50 Only)
	101129	1	9-1/2 x 3" Compound Pulley (for AD-30 Only)
3	100110	1	4L-500 V-Belt (idler to motor) 60 Hz (for use on AD-30 Only)
	100112	1	4L-610 V-Belt (idler to motor) 60 Hz (for use on AD-50 Only)
4	154301	2	5/16-18 x 1" Allen Setscrew
5	100705	1	3/16" x 3/16" x 1-3/8" Key
6	882576	1	Idler Bearing Assembly Complete (includes illus. nos. 5 through 12)
7	150617	2	3/8-16 x 1" Hex Head Machine Bolt
8	153005	2	3/8" Lock Washer
9	153004	2	3/8" Flat Washer
10	801009	1	Idler Square Washer
11	152004	1	5/16-18 Hex Nut
12	150509	1	5/16-18 x 3" Hex Head Machine Bolt

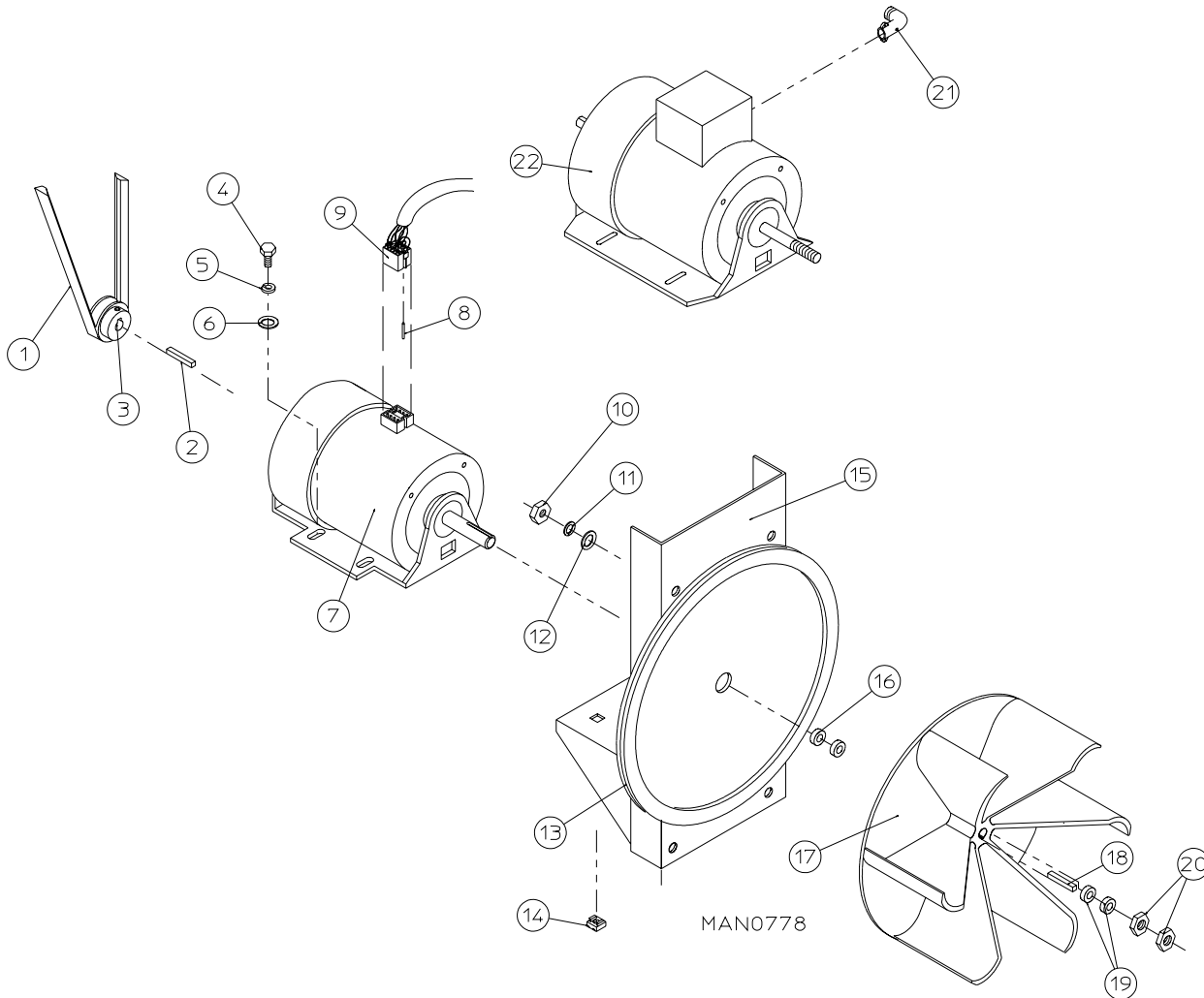

<u>Illus. No.</u>	<u>Part No.</u>	<u>Qty.</u>	<u>Description</u>
1	100112	1	4L-610 V-Belt (motor to idler)
2	100701	1	3/16" x 3/16" x 1" Key (for use on 3ø models Only)
3	101130	1	5/8" x 2-1/2" Motor Pulley (for use on 60 Hz models Only)
	101139	1	5/8" x 2-3/4" Motor Pulley (for use on 50 Hz models Only)
4	150501	4	5/16-18 x 3/4" Hex Head Machine Bolt
5	153002	4	5/16" Lock Washer
6	153001	4	5/16" Flat Washer
7	100069	1	3/4 HP 120-230v 1ø Totally Enclosed, Fan-Cooled (T.E.F.C.) Motor with Plug (56Z frame) (for 60 Hz models mfd. as of September 14, 1992)
	100068	1	3/4 HP 240v 1ø Totally Enclosed, Fan-Cooled (T.E.F.C.) Motor with Plug (56Z frame) (for 50 Hz models mfd. as of September 14, 1992)
8	122701	8	Socket Terminal ONLY
	122801	1	Pin/Socket Extraction Tool...Not Illustrated
9	137030	1	8-Pin Housing Connector
10	152004	4	5/16-18 Hex Nut
11	153002	4	5/16" Lock Washer
12	153001	4	5/16" Flat Washer

<u>Illus. No.</u>	<u>Part No.</u>	<u>Qty.</u>	<u>Description</u>
13	117604	4	Neoprene Sponge Tape (sold by the foot) (for models mfd. as of August 6, 1998)
	117600	4	Noise Suppressor Tape (sold by the foot) (for models mfd. as of August 6, 1998)
14	154000	4	5/16-18 Tinnerman Nut
15	800905	1	AD-50 Non-Reversing Motor Mount ONLY (56Z frame)
	803972*	1	3/4 HP 120-230v 1 ϕ 60 Hz Non-Reversing Totally Enclosed, Fan-Cooled (T.E.F.C.) Motor Mount Assembly Complete (includes illus. nos. 3 through 6 and 13 through 22) (for models mfd. prior to September 14, 1992)
	803973*	1	3/4 HP 240v 1 ϕ 50 Hz Non-Reversing Totally Enclosed, Fan-Cooled (T.E.F.C.) Motor Mount Assembly Complete (includes illus. nos. 3 through 6 and 13 through 22) (for models mfd. prior to September 14, 1992)
	803970*	1	1/2 HP 208/230/380/460v 3 ϕ 60 Hz Non-Reversing Totally Enclosed, Fan-Cooled (T.E.F.C.) Motor Mount Assembly Complete (includes illus. nos. 2 through 6 and 13 through 22)
	803971*	1	1/2 HP 208/230/380/460v 3 ϕ 50 Hz Non-Reversing Totally Enclosed, Fan-Cooled (T.E.F.C.) Motor Mount Assembly Complete (includes illus. nos. 2 through 6 and 13 through 22)
	803988*	1	3/4 HP 120/230v 1 ϕ 60 Hz Totally Enclosed, Fan-Cooled (T.E.F.C.) Motor Mount Assembly Complete with Plug Motor (includes illus. nos. 3 through 7 and 13 through 20) (for models mfd. as of September 14, 1992)
	803989*	1	3/4 HP 240v 1 ϕ 50 Hz Totally Enclosed, Fan-Cooled (T.E.F.C.) Motor Mount Assembly Complete with Plug Motor (includes illus. nos. 3 through 7 and 13 through 20) (for models mfd. as of September 14, 1992)
16	153050	2	1/2" S.A.E. Flat Washer
17	100604	1	12-1/2" Impellor with 1/2" Bore
18	100702	1	1/8" x 1/8" x 1-1/2" Key
19	153050	2	1/2" S.A.E. Flat Washer
20	152006	2	1/2-20 Left Hand Jam Nut
21	120200	1	3/8" x 90° Connector
22	100033*	1	3/4 HP 120/230v 1 ϕ Totally Enclosed, Fan-Cooled (T.E.F.C.) Motor (56Z frame) (for 60 Hz models mfd. prior to September 14, 1992)
	100034	1	3/4 HP 230v 1 ϕ Totally Enclosed, Fan-Cooled (T.E.F.C.) Motor (56Z frame) (for 50 Hz models mfd. prior to September 14, 1992)
	100007*	1	1/2 HP 208/230/380/460v 3 ϕ 50/60 Hz Totally Enclosed, Fan-Cooled (T.E.F.C.) Motor (56Z frame)

* Specify voltage when ordering.

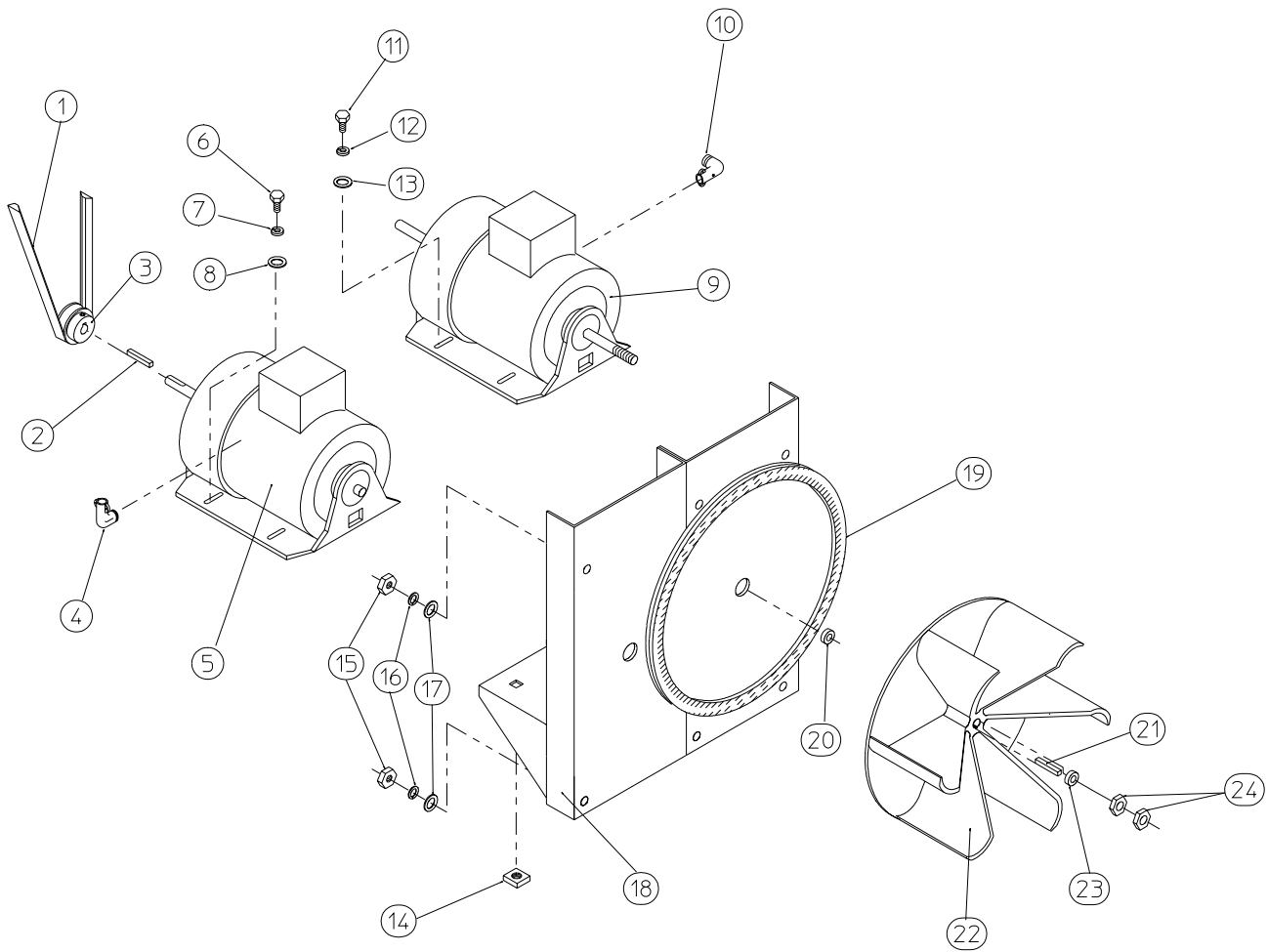

MAN0250

<u>Illus. No.</u>	<u>Part No.</u>	<u>Qty.</u>	<u>Description</u>
1	100112	1	4L-610 V-Belt (motor to idler)
2	100701	1	3/16" x 3/16" x 1" Key
3	101132	1	5/8" x 2" Motor Pulley (60 Hz Only)
	101133	1	5/8" x 2-1/4" Motor Pulley (50 Hz Only)
4	120200	1	3/8" x 90° Connector
5*	181003	1	1/2 HP 208/230/380/460v 3ø 50/60 Hz Totally Enclosed, Fan-Cooled (T.E.F.C.) Motor (56Z frame)
6	150501	4	5/16-18 x 3/4" Hex Head Machine Bolt
7	153002	4	5/16" Lock Washer
8	153001	4	5/16" Flat Washer
9*	100007	1	1/2 HP 208/230/380/460v 3ø 50/60 Hz Totally Enclosed, Fan-Cooled (T.E.F.C.) Motor (56Z frame)
10	120200	1	3/8" x 90° Connector
11	150501	4	5/16-18 x 3/4" Hex Head Machine Bolt
12	153002	4	5/16" Lock Washer
13	153001	4	5/16" Flat Washer
14	154000	8	5/16" Tinnerman Nut
15	152004	7	5/16" Hex Nut
16	153002	4	5/16" Lock Washer
17	153001	4	5/16" Flat Washer
18	800912	1	AD-50 Reversing Motor Mount ONLY (56Z frame)
	803990*	1	AD-50 Reversing Totally Enclosed, Fan-Cooled (T.E.F.C.) Motor Mount Assembly Complete (includes illus. nos. 2 through 14 and 18 through 24) For 60 Hz Models ONLY
	803991*	1	AD-50 Reversing Totally Enclosed, Fan-Cooled (T.E.F.C.) Motor Mount Assembly Complete (includes illus. nos. 2 through 14 and 18 through 24) For 50 Hz Models ONLY
19	117604	4	Neoprene Sponge Tape (sold by the foot) (for models mfd. as of August 6, 1998)
	117600	4	Noise Suppressor Tape (sold by the foot) (for models mfd. as of August 6, 1998)
20	153050	1	1/2" S.A.E. Flat Washer
21	100702	1	1/8" x 1/8" x 1-1/2" Key
22	100604	1	12-1/2" Impellor with 1/2" Bore
23	153050	2	1/2" S.A.E. Flat Washer
24	152006	2	1/2-20 Left Hand Jam Nut

* Specify voltage when ordering.

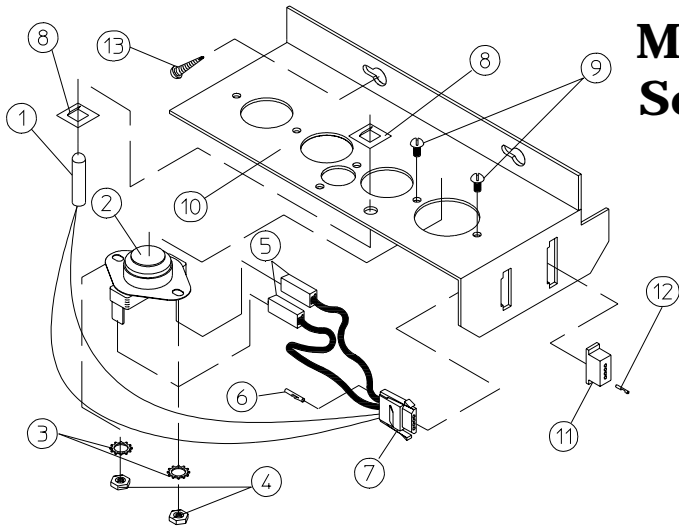

Noncomputer Sensor Bracket Assembly

Microprocessor Sensor Bracket Assembly

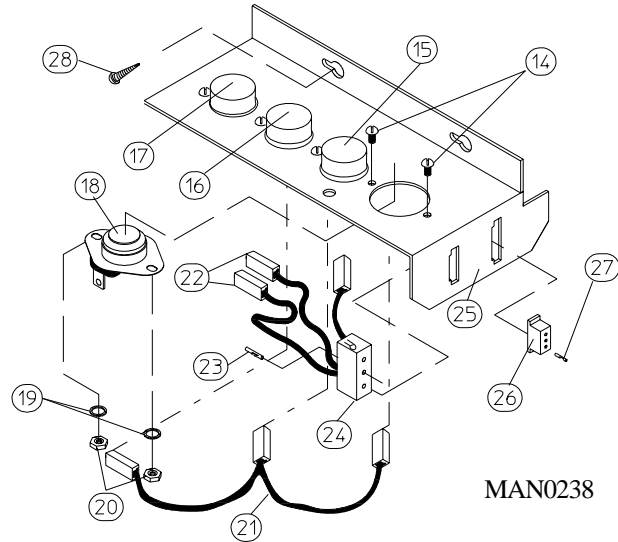

MAN0238

<u>Illus. No.</u>	<u>Part No.</u>	<u>Qty.</u>	<u>Description</u>
1	880251	1	1/4" Temperature Sensor Probe Assembly (includes illus. nos. 1 and 5 through 8)
2	130301	1	225° Manual Reset Thermostat (for models mfd. as of June 14, 1999)
	130103	1	225° Automatic Reset Thermostat (for models mfd. prior to June 14, 1999)
3	153010	2	#6 Star Washer
4	152000	2	#6-32 Hex Nut
5	121028	2	Insulated Terminal ONLY
6	122701	4	Socket Terminal ONLY
7	122605	1	4-Pin Socket Connector ONLY
8	154007	2	1/4" Tinnerman Push On Fastener
9	150005	2	#6-32 x 1/4" Round Head Machine Screw
10	801425	1	Microprocessor Sensor Bracket Assembly Complete (includes illus. nos. 1 through 10)
	305007	1	Universal Sensor Bracket ONLY
11	122604	1	4-Pin Connector ONLY
12	122700	4	Pin Terminal ONLY
13	150301	2	#8-18 x 7/16" Phillips Pan Head TEK Screw
14	150000	*	#6-32 x 1/4" Slotted Round Head Machine Screw
15	130111	1	130° Thermostat (for models mfd. as of August 1, 1993)
	130100	1	150° Thermostat (for models mfd. prior to August 1, 1993)
	130109	1	140° Thermostat (for UniDryer® models Only)

<u>Illus. No.</u>	<u>Part No.</u>	<u>Qty.</u>	<u>Description</u>
16	130100	1	150° Thermostat (for models mfd. as of August 1, 1993)
	130107	1	160° Large Thermostat (for UniDryer® models Only)
17	130302	1	225° Manual Reset Thermostat (for models mfd. as of June 14, 1999)
	130103	1	225° Automatic Reset Thermostat (for ALL UniDryer® models and models mfd. between August 1, 1993 and June 14, 1999)
18	130101	1	180° Thermostat
19	153010	*	#6 Star Washer
20	152000	*	#6-32 Hex Nut
21	840065	1	Sensor Jumper (4) ONLY (for ALL UniDryer® models and models mfd. as of August 1, 1993)
	840063	1	Sensor Jumper (3) ONLY (for models mfd. prior to August 1, 1993)
22	121028	*	Insulated Terminal ONLY
23	122701	*	Socket Terminal ONLY
24	122605	1	4-Pin Socket Connector ONLY (for ALL UniDryer® models and models mfd. as of August 1, 1993)
	122609	1	3-Pin Socket Connector ONLY (for models mfd. prior to August 1, 1993)
	831702	1	Sensor (3) Bracket Harness Assembly (for models mfd. prior to August 1, 1993) (includes illus. nos. 22 through 24)
	840062	1	Sensor (4) Bracket Harness Assembly (for ALL UniDryer® models and models mfd. as of August 1, 1993) (includes illus. nos. 22 through 24)
25	801405	1	Noncomputer Sensor (3) Bracket Assembly Complete - Includes Thermostats (for models mfd. prior to August 1, 1993) (includes illus. nos. 14 through 16, and 18 through 25)
	801411	1	Noncomputer Sensor (4) Bracket Assembly Complete - Includes Thermostats For UniDryer® Models ONLY (includes illus. nos. 14 through 25)
	801418	1	Noncomputer Sensor (4) Bracket Assembly Complete - Includes Thermostats (for models mfd. as of August 1, 1993) (includes illus. nos. 14 through 25)
	305007	1	Universal Sensor Bracket ONLY
	801430	1	Noncomputer Sensor (4) Bracket Assembly Complete - Includes Thermostats (for AD-30 models mfd. as of August 1, 1993) (includes illus. nos. 14 through 25)
26	122604	1	4-Pin Connector ONLY (for ALL UniDryer® models and models mfd. as of August 1, 1993)
	122608	1	3-Pin Connector ONLY (for models mfd. prior to August 1, 1993)
27	122700	**	Pin Terminal ONLY
	122801	1	Pin/Socket Extraction Tool...Not Illustrated
28	150301	2	#8-18 x 7/16" Phillips Pan Head TEK Screw

* Quantity is 4 or 5.

** Quantity is 3 or 4.

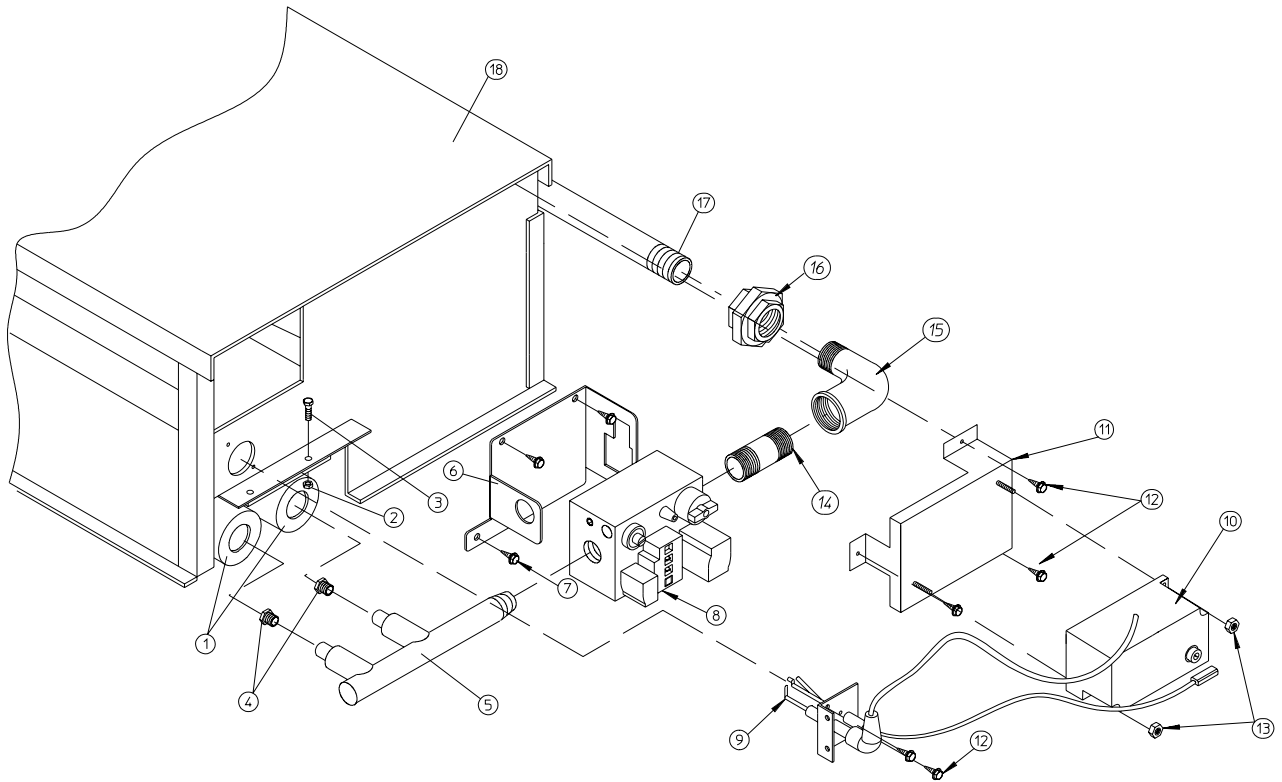

For Models Mfd. as of April 10, 2000

<u>Illus. No.</u>	<u>Part No.</u>	<u>Qty.</u>	<u>Description</u>
1	141105	2	Large Gas "T" Burner
2	151001	2	#8-32 Pal Nut
3	150108	2	#8-32 x 1/2" Pan Head Machine Screw
4	-----	2	(refer to DSI Burner Orifice Listing on page 84)
5	141230	1	1/2" Direct Spark Ignition (DSI) Manifold (2-port)
6	318714	1	1-Piece Gas Valve Bracket
7	150309	5	#10-16 x 1/2" Hex Head TEK Crimptite Screw
8	128927	1	Gas Valve
9	880134	1	Ignitor/Flame-Probe Assembly
10	128935	1	Direct Spark Ignition (DSI) Johnson Module Three (3) Tries
11	810030	1	Johnson Direct Spark Ignition (DSI) Module Mounting Bracket
12	150300	9	#10-16 x 1/2" Hex Washer TEK Screw
13	152013	2	#6-32 Hex Nut
14	142707	1	1/2" x 1-1/2" Black Nipple
	142700	1	1/2" Close Nipple (for models mfd. as of November 14, 2001)
15	142506	1	1/2" Street Elbow
16	142600	1	1/2" Black Union
17	142809	1	1/2" x 29-1/8" Pipe
18	850858	1	AD-30/AD-50 Direct Spark Ignition (DSI) Burner Box ONLY
	-----	1	Direct Spark Ignition (DSI) Burner Box Assembly (refer to DSI Burner Assembly Listing on page 84)
	-----	1	Direct Spark Ignition (DSI) Liquid Propane (L.P.) Conversion Kit (refer to DSI L.P. Conversion Kit Listing on page 84)

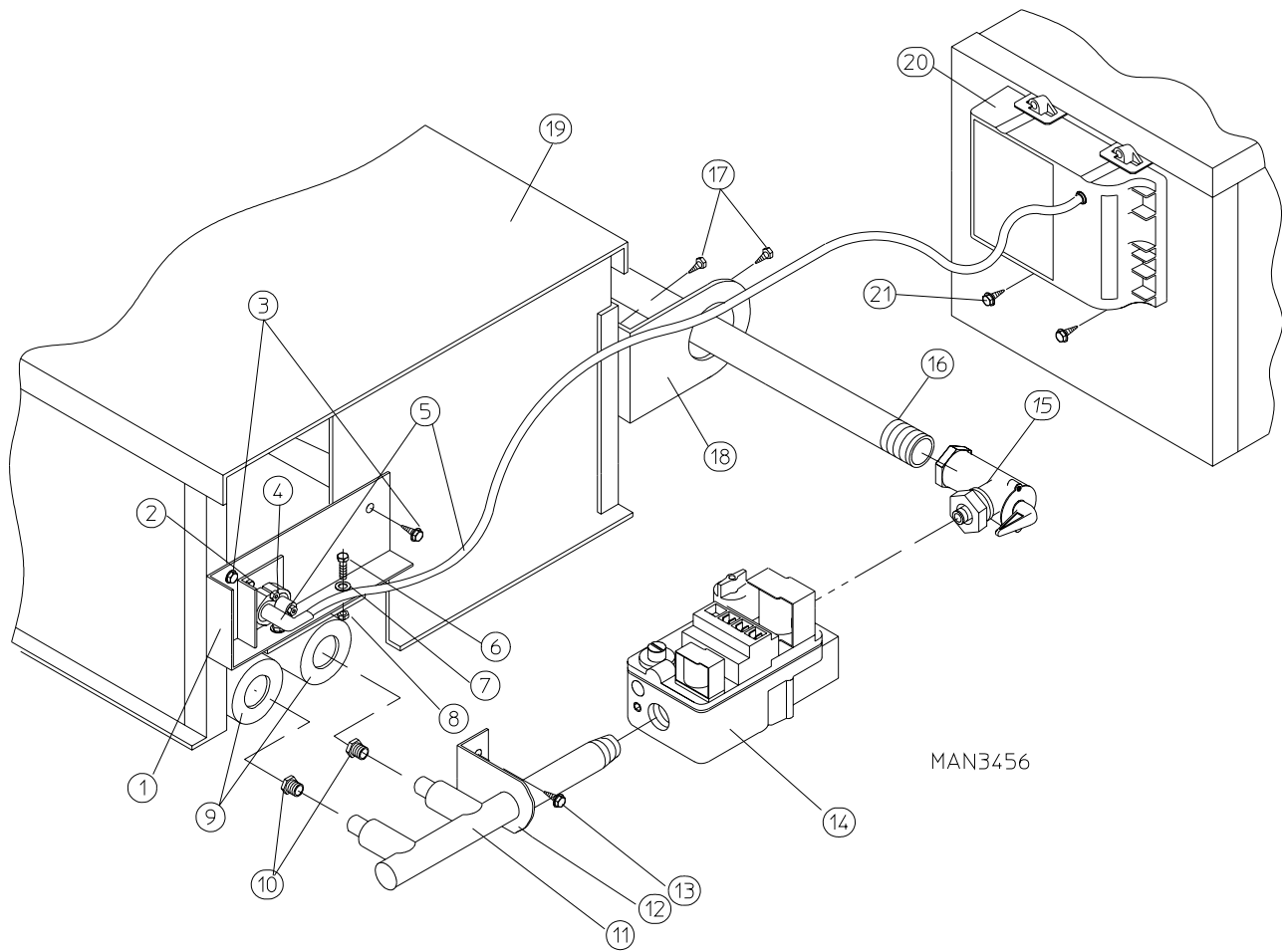

For Models Mfd. prior to April 10, 2000

<u>Illus. No.</u>	<u>Part No.</u>	<u>Qty.</u>	<u>Description</u>
1	318030	1	Direct Spark Ignition (DSI) Burner Shield (2-tube)
2	150300	2	#10-16 x 1/2" Hex Washer TEK Screw
3	150309	2	#10-16 x 1/2" Hex Head TEK Crimptite Screw
4	128915	1	Direct Spark Ignition (DSI) Ignitor/Flame-Probe Assembly
	880134	1	Ignitor/Flame-Probe Kit Assembly (includes high voltage [HV] wire and connector)
5	880330	1	High Voltage (HV) Wire and Connector Assembly
6	150103	2	#8-32 x 1/2" Pan Head Machine Screw
7	153000	2	#8 Steel Burr
8	151001	2	#8-32 Pal Nut
9	141105	2	Large Tube Burner ONLY
10	-----	2	Burner Orifice (refer to DSI Burner Orifice Listing on page 84)
11	141230	1	1/2" Direct Spark Ignition (DSI) Manifold (2-port)
12	318700	1	Pipe Bracket (bent)
13	150300	2	#10-16 x 1/2" Hex Washer TEK Screw
14	128927	1	1/2" 24 VAC Redundant Gas Valve (natural gas)
	140411	1	1/2" Valve Conversion Kit (liquid propane [L.P.])
	880960	1	1/2" Direct Spark Ignition (DSI) Gas Valve/Liquid Propane (L.P.) Kit Combination
15	881367	1	1/2" Union Shut Off with Tail Piece
16	142809	1	1/2" x 29-1/8" Pipe
17	150309	4	#10-16 x 1/2" Hex Head TEK Crimptite Screw
18	318700	1	Pipe Bracket (bent)
19	850851	1	Non-Heat Reclaimer Burner Box ONLY
	850861	1	Heat Reclaimer Burner Box ONLY
	-----	1	Direct Spark Ignition (DSI) Burner Assembly (refer to DSI Burner Assembly Listing on page 84)
20	880815	1	Direct Spark Ignition (DSI) Module ONLY
21	150299	4	#10 x 1" Hex Washer TEK Screw
---	-----	1	Direct Spark Ignition (DSI) Liquid Propane (L.P.) Conversion Kit (refer to DSI L.P. Conversion Kit Listing on page 84)

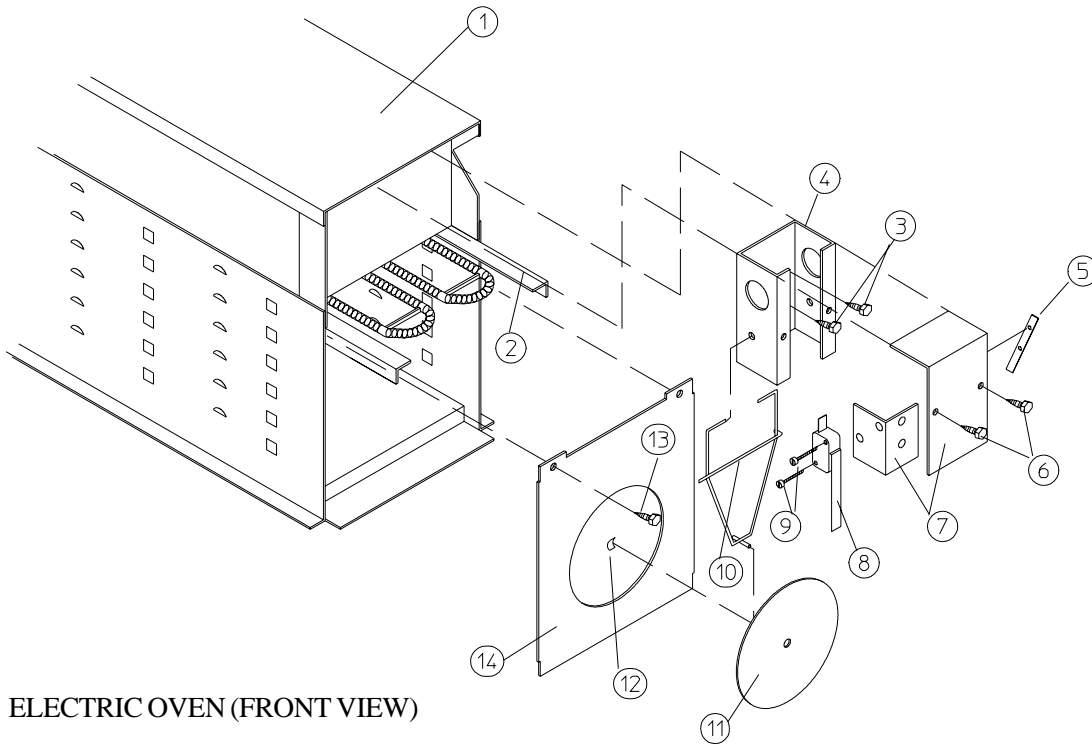

ELECTRIC OVEN (FRONT VIEW)

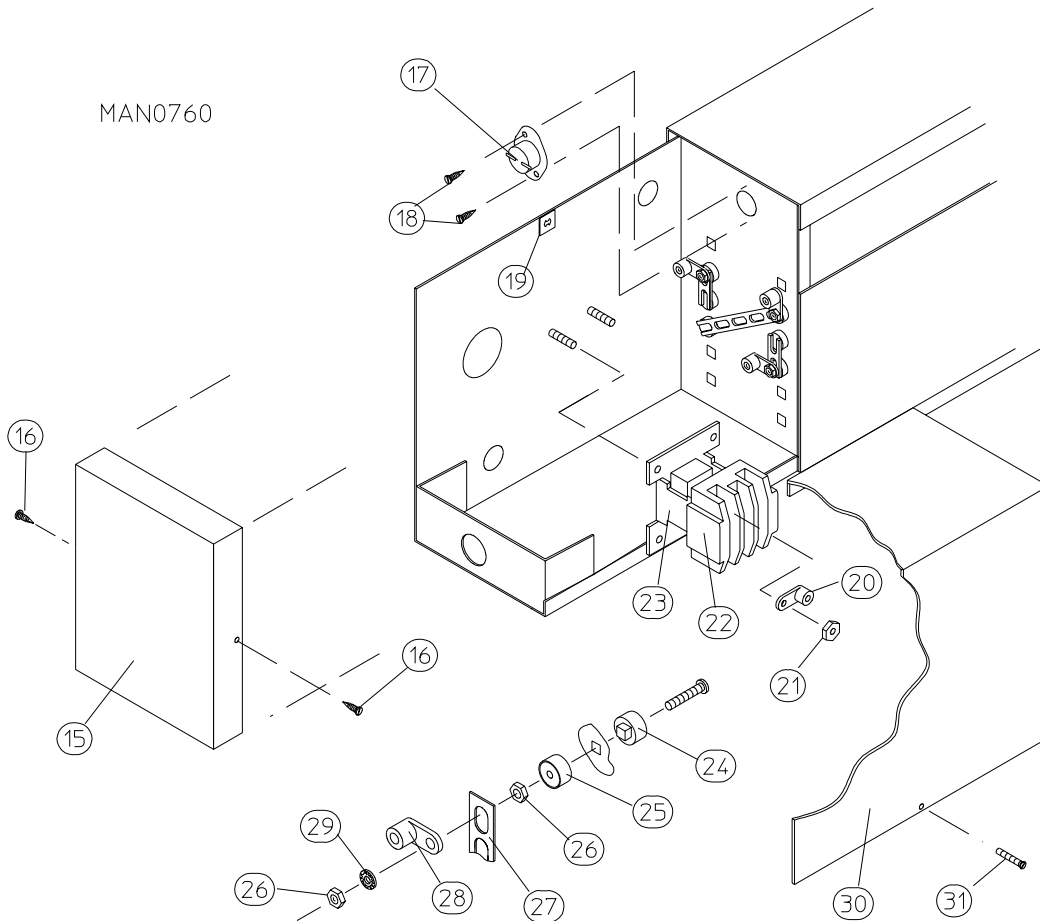

MAN0760

ELECTRIC OVEN (REAR VIEW)

<u>Illus. No.</u>	<u>Part No.</u>	<u>Qty.</u>	<u>Description</u>
1	803007*	1	Large Electric Oven Box ONLY
	-----*	1	Electric Oven Assembly Complete
2	-----*	-	Electric Element
3	150300	2	#10-16 x 1/2" Hex Washer TEK Screw
4	802800	1	Sail Switch Box with Bracket and Cover ONLY
	802801	1	Sail Switch Box Assembly Complete (includes illus. nos. 4 through 12)
5	154004	1	Twin Speed Nut
6	150309	2	#10-16 x 1/2" Hex Head TEK Crimptite Screw
7	802799	1	Sail Switch Box Cover and Bracket ONLY
8	122200	1	Sail Switch ONLY
9	150303	2	#4 x 3/4" Pan Head "A" Machine Screw
10	105500	1	Sail Switch Actuator Rod
11	319202	1	Sail Switch Damper (flat)
12	154002	1	1/8" Push On Fastener
13	150300	2	#10-16 x 1/2" Hex Washer TEK Screw
14	803100	1	Electric Oven Front Cover ONLY
15	320611	1	Large Relay Box Cover ONLY
16	150402	2	#10-24 x 5/8" Slotted Truss Head Machine Screw
17	130400	1	290° Hi-Limit Thermostat
18	150300	2	#10-16 x 1/2" Hex Washer TEK Screw
19	154001	2	#10-24 Speed Nut
20	121010	1	L-70 Ground Lug
21	152014	3	1/4-20 Free Spin Wash Nut
22	-----*	1	Oven Relay
23	-----*	1	Oven Relay Replacement Coil
24	120081	-	Internal Ceramic Insulator (two [2] per element)
25	120080	-	External Ceramic Insulator (two [2] per element)
26	152008	-	#10-32 Hex Nut (four [4] per element)
27	121011	-	Bus Bar (sold by the foot)
28	-----*	-	Terminal Lug
29	153009	-	#10 Star Washer (two [2] per element)
30	321301	1	Large Electric Oven Right Side Cover ONLY
31	150402	2	#10-24 x 5/8" Truss Head Machine Screw

* Refer to **ADE-30/ADE-50 Electric Oven Component Application Charts** on **page 83**.

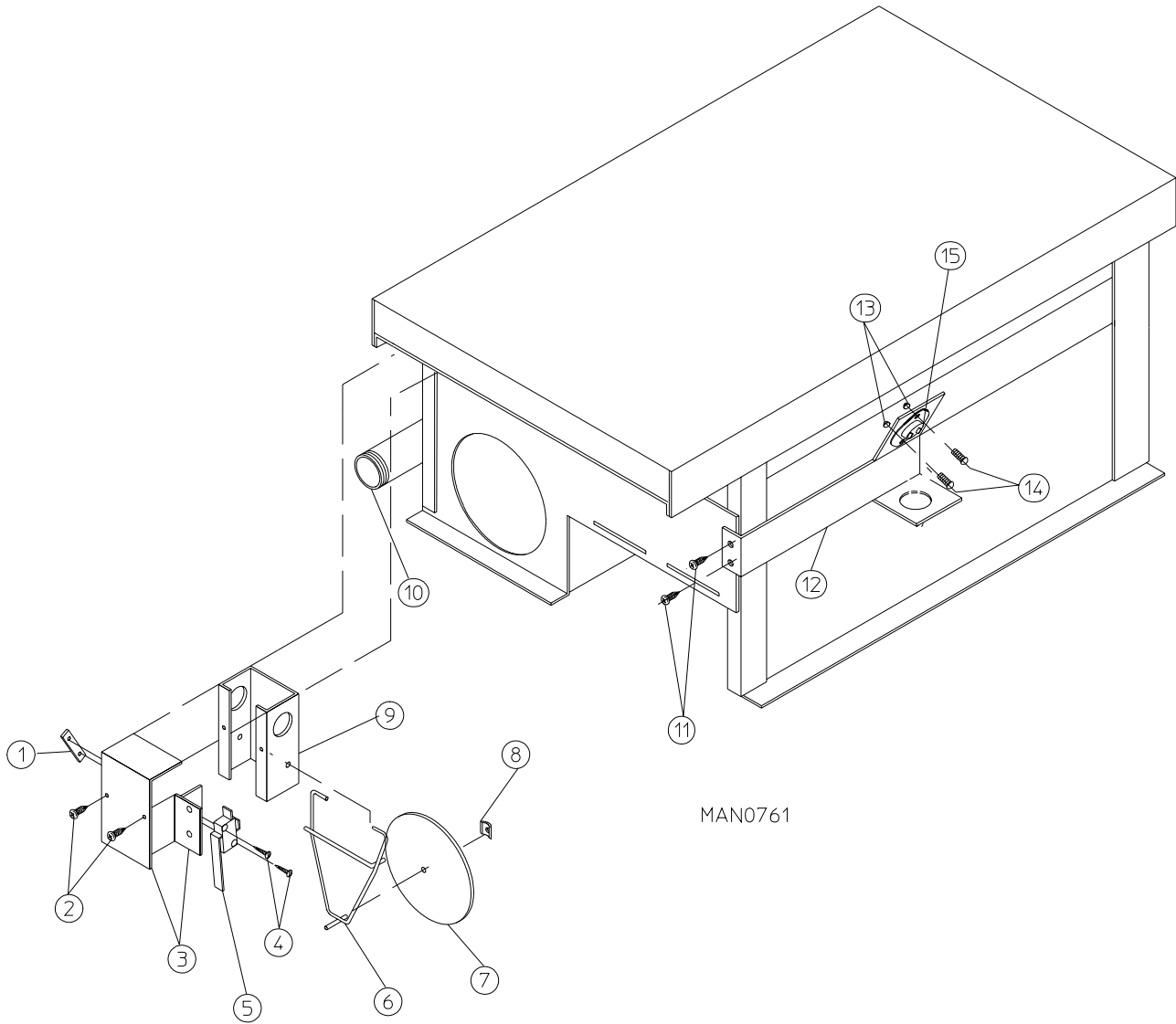

<u>Illus. No.</u>	<u>Part No.</u>	<u>Qty.</u>	<u>Description</u>
1	154004	1	Twin Speed Nut
2	150309	2	#10-16 x 1/2" Hex Head TEK Crimptite Screw
3	802799	1	Sail Switch Box Cover and Bracket ONLY
4	150303	2	#4 x 3/4" Pan Head "A" Machine Screw
5	122200	1	Sail Switch ONLY
6	105500	1	Sail Switch Actuator Rod
7	319202	1	Sail Switch Damper (flat)
8	154002	1	1/8" Push On Fastener
9	802800	1	Sail Switch Box with Cover and Bracket ONLY
	802801	1	Sail Switch Assembly Complete (includes illus. nos. 1 through 8)
10	142809	1	1/2" x 29-1/8" Pipe/Nipple
11	150309	2	#10-16 x 1/2" Hex Head TEK Crimptite Screw
12	319704	1	Hi-Limit Mounting Bracket ONLY
13	151000	2	#6-32 Pal Nut
14	150001	2	#6-32 x 1/2" Phillips Round Head Machine Screw
15	130403	1	330° Automatic Reset Hi-Limit Thermostat ONLY

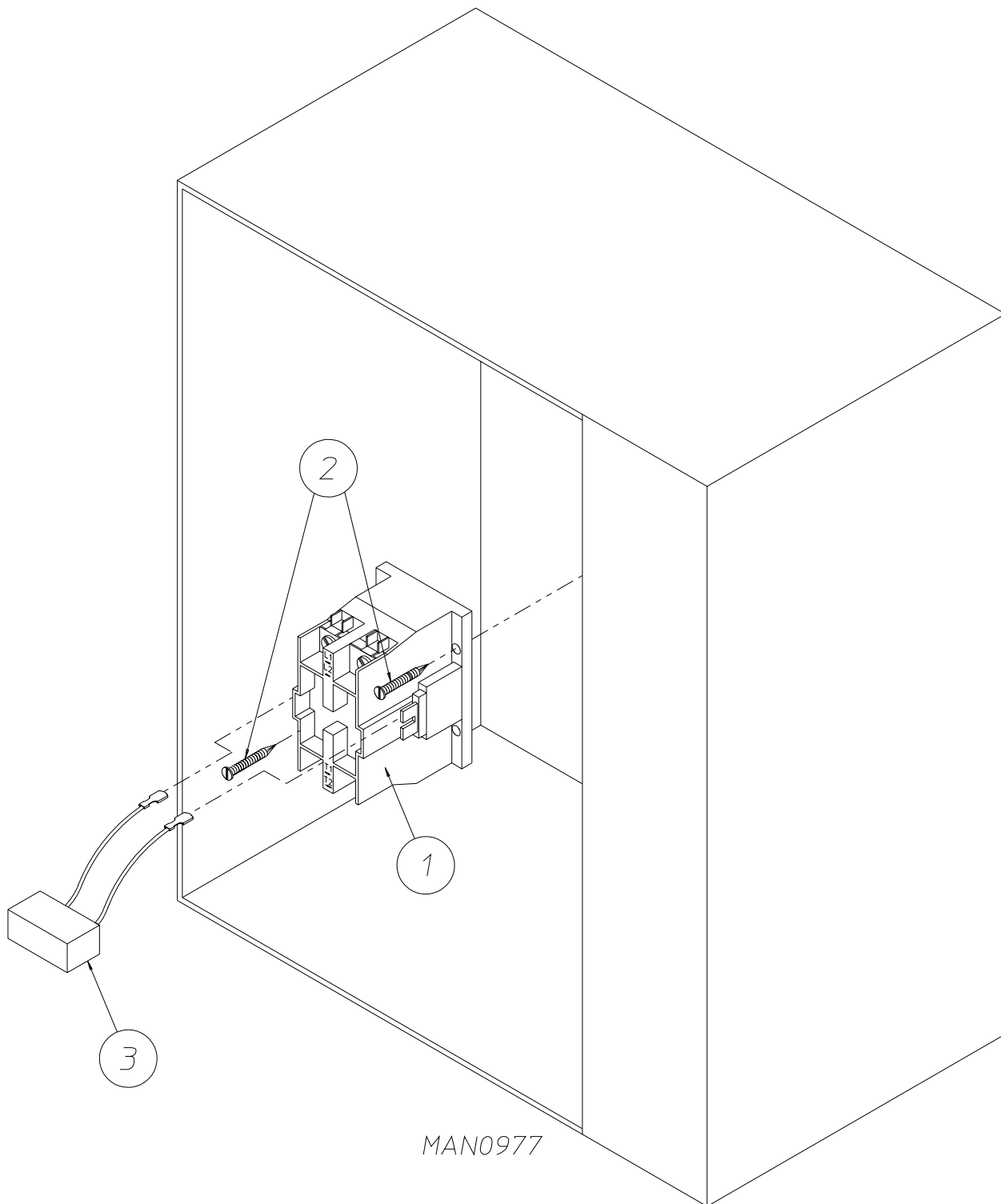

<u>Illus. No.</u>	<u>Part No.</u>	<u>Qty.</u>	<u>Description</u>
1	132475	1	2-Pole Contactor - 24 VAC
2	150299	2	#10 x 1" Hex Washer TEK Screw
3	824828	1	RC Network with Connectors (for computer models Only)
--	322809	1	Back Electrical Box Cover...Not Illustrated
--	150301	4	#8-18 x 7/16" Phillips Round Head TEK Screw...Not Illustrated

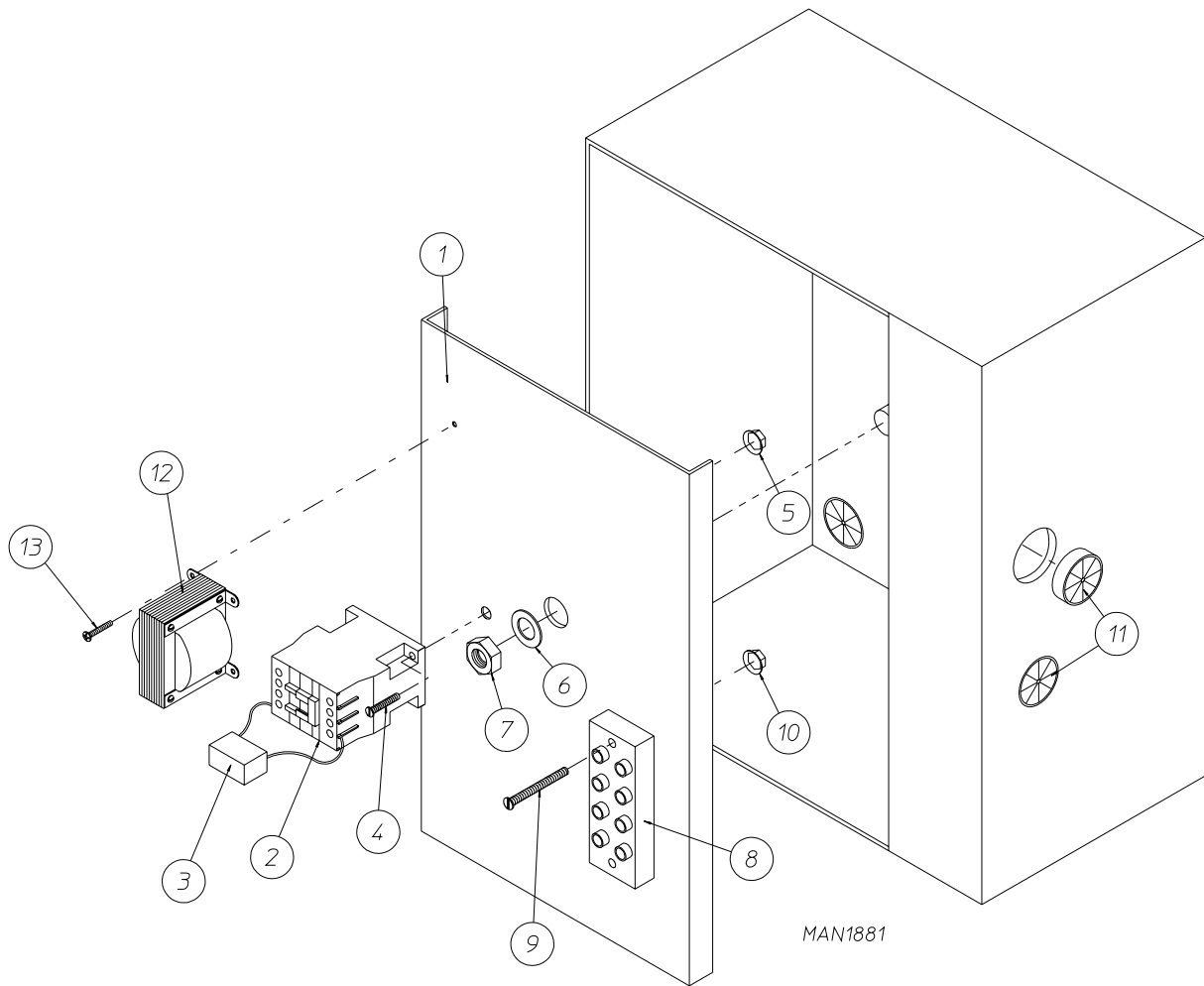

<u>Illus. No.</u>	<u>Part No.</u>	<u>Qty.</u>	<u>Description</u>
1	322812	1	Back Electrical Box Component Plate
2	132430	1	Impellor Contactor (208/230/240v, 50/60 Hz) - 24 Volt Coil
3	137015	1	RC Network (for computer models Only)
4	150103	2	#8-32 x 3/4" Phillips Round Head Machine Screw
5	151001	2	#8-32 Pal Nut
6	153002	1	5/16" Lock Washer
7	152004	1	5/16-18 Hex Nut
8	120701	1	4-Position Terminal Block
9	150008	2	#6-32 x 1-1/4" Slotted Round Head Machine Screw
10	151000	2	#6-32 Pal Nut
11	121300	3	Open/Closed Bushing
12	-----	1	Transformer (refer to ADE-30/ADE-50 Step Down Transformer Usage Listing For Electric Dryers on page 81) (refer to ADE-30/ADE-50 Step Down Transformer Usage Listing For Gas/Steam Dryers on page 82)
13	150300	2	#10-16 x 1/2" Hex Washer TEK Screw
---	322809	1	Back Electrical Box Cover...Not Illustrated
---	150301	4	#8-18 x 7/16" Phillips Pan Head TEK Screw...Not Illustrated

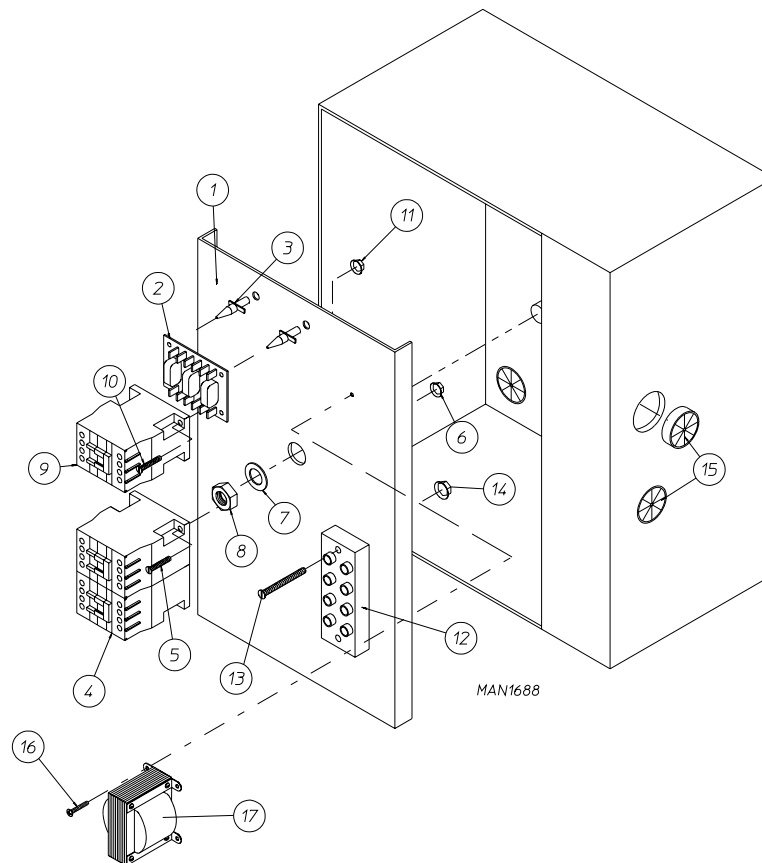

<u>Illus. No.</u>	<u>Part No.</u>	<u>Qty.</u>	<u>Description</u>
1	322812	1	Back Electrical Box Component Plate
2	137060	1	Arc Suppressor (A.S.) Board
3	137013	2	Nylon Standoff
4	882386	1	Reversing Contactor (208/230/240v, 50/60 Hz) 24 Volt Coil
5	150103	2	#8-32 x 3/4" Phillips Round Head Machine Screw
6	151001	2	#8-32 Pal Nut
7	153002	1	5/16" Lock Washer
8	152004	1	5/16-18 Hex Nut
9	132430	1	Impellor Contactor (208/230/240v, 50/60 Hz) 24 Volt Coil
	132432	1	Impellor Contactor Replacement Coil (208/230/240v, 50/60 Hz) 24 Volt Coil
10	150103	2	#8-32 x 3/4" Phillips Round Head Machine Screw
11	151001	2	#8-32 Pal Nut
12	120701	1	4-Position Terminal Block
13	150008	2	#6-32 x 1-1/4" Slotted Round Head Machine Screw
14	151000	2	#6-32 Pal Nut
15	121300	3	Open/Closed Bushing
16	150300	2	#10-16 x 1/2" Hex Washer TEK Screw
17	-----	-	Transformer (refer to ADE-30/ADE-50 Step Down Transformer Usage Listing For Electric Dryers on page 81) (refer to ADE-30/ADE-50 Step Down Transformer Usage Listing For Gas/Steam Dryers on page 82)
---	322809	1	Back Electrical Box Cover...Not Illustrated
---	150301	4	#8-18 x 7/16" Phillips Pan Head TEK Screw...Not Illustrated

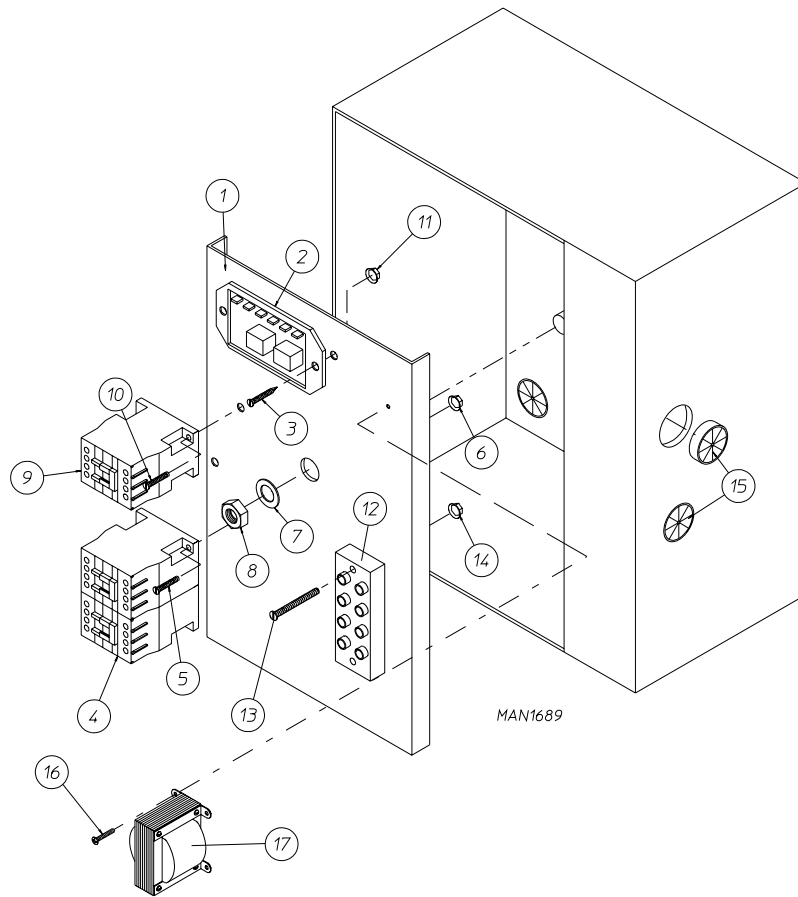

<u>Illus. No.</u>	<u>Part No.</u>	<u>Qty.</u>	<u>Description</u>
1	322812	1	Back Electrical Box Component Plate
2	132198	1	Reversing Timer (50/60 Hz) 24 VAC
3	150301	4	#8-18 x 7/16" Phillips Round Head TEK Screw
4	882386	1	Reversing Contactor (208/230/240v, 50/60 Hz) 24 VAC Coil
5	150103	2	#8-32 x 3/4" Phillips Round Head Machine Screw
6	151001	2	#8-32 Pal Nut
7	153002	1	5/16" Lock Washer
8	152004	1	5/16-18 Hex Nut
9	132430	1	1 HP Contactor
10	150103	2	#8-32 x 3/4" Phillips Round Head Machine Screw
11	151001	2	#8-32 Pal Nut
12	120701	1	4-Position Terminal Block
13	150008	2	#6-32 x 1-1/4" Slotted Round Head Machine Screw
14	151000	2	#6-32 Pal Nut
15	121300	3	Open/Closed Bushing
16	150300	2	#10-16 x 1/2" Hex Washer TEK Screw
17	-----	-	24 VAC Transformer (refer to ADE-30/ADE-50 Step Down Transformer Usage Listing For Electric Dryers on page 81) (refer to ADE-30/ADE-50 Step Down Transformer Usage Listing For Gas/Steam Dryers on page 82)
--	322809	1	Back Electrical Box Cover...Not Illustrated
--	150301	4	#8-18 x 7/16" Phillips Pan Head TEK Screw...Not Illustrated

For Models Mfd. as of January 13, 1995

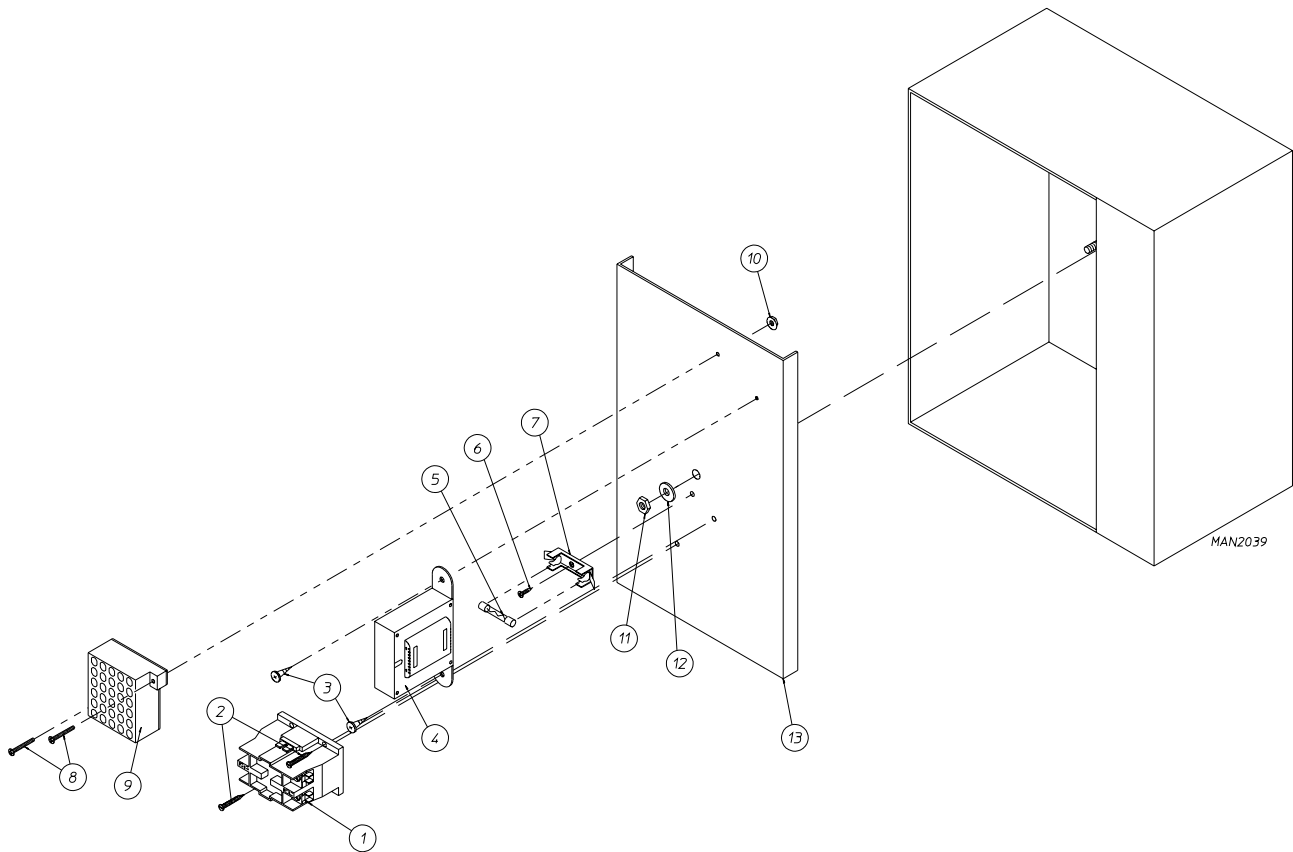

<u>Illus. No.</u>	<u>Part No.</u>	<u>Qty.</u>	<u>Description</u>
1	132475	1	2-Pole Contactor - 24 VAC
2	150299	2	#10 x 1" Hex Washer TEK Screw
3	150300	2	#10-16 x 1/2" Hex Washer TEK Screw
4	-----	-	Transformer (refer to ADE-30/ADE-50 Step Down Transformer Usage Listing For Electric Dryers on page 81) (refer to ADE-30/ADE-50 Step Down Transformer Usage Listing For Gas/Steam Dryers on page 82)
5	136057	*	1/2-Amp (Slo-Bl) Fuse ONLY
6	150301	*	#8-18 x 7/16" Phillips Pan Head TEK Screw
7	136008	*	Fuse Block/Strip ONLY
8	150002	2	#6-32 x 1" Phillips Round Head Machine Screw
9	120715	1	30-Position Terminal Block ONLY
10	151000	2	#6-32 Pal Nut
11	152004	1	5/16-18 Hex Nut
12	153002	1	5/16-18 Lock Washer
13	305520	1	Rear Contactor Plate ONLY
---	322809	1	Back Electrical Box Cover...Not Illustrated
---	150301	4	#8-18 x 7/16" Phillips Pan Head TEK Screw...Not Illustrated

* As required.

For Models Mfd. prior to January 13, 1995

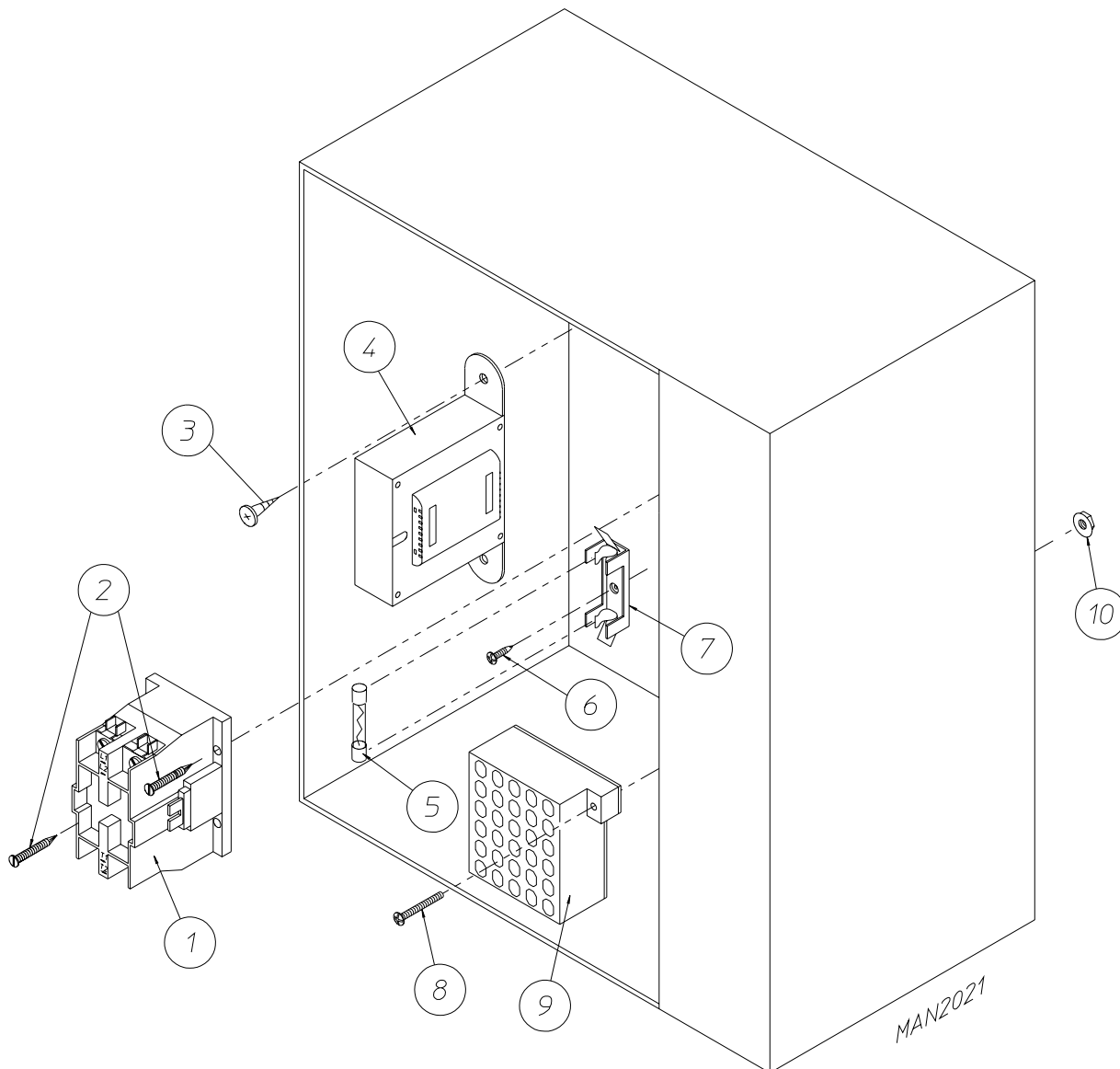

<u>Illus. No.</u>	<u>Part No.</u>	<u>Qty.</u>	<u>Description</u>
1	132475	1	2-Pole Contactor - 24 VAC
2	150299	2	#10 x 1" Hex Washer TEK Screw
3	150300	2	#10-16 x 1/2" Hex Washer TEK Screw
4	141403	1	Transformer - 24 VAC
5	136057	*	1/2-Amp (Slo-Blo) Fuse ONLY
6	150301	*	#8-18 x 7/16" Phillips Pan Head TEK Screw
7	136008	*	Fuse Block/Strip ONLY
8	150002	2	#6-32 x 1" Phillips Round Head Machine Screw
9	120715	1	30-Position Terminal Block ONLY
10	151000	2	#6-32 Pal Nut
---	322809	1	Back Electrical Box Cover...Not Illustrated
---	150301	4	#8-18 x 7/16" Phillips Pan Head TEK Screw...Not Illustrated

* As required.

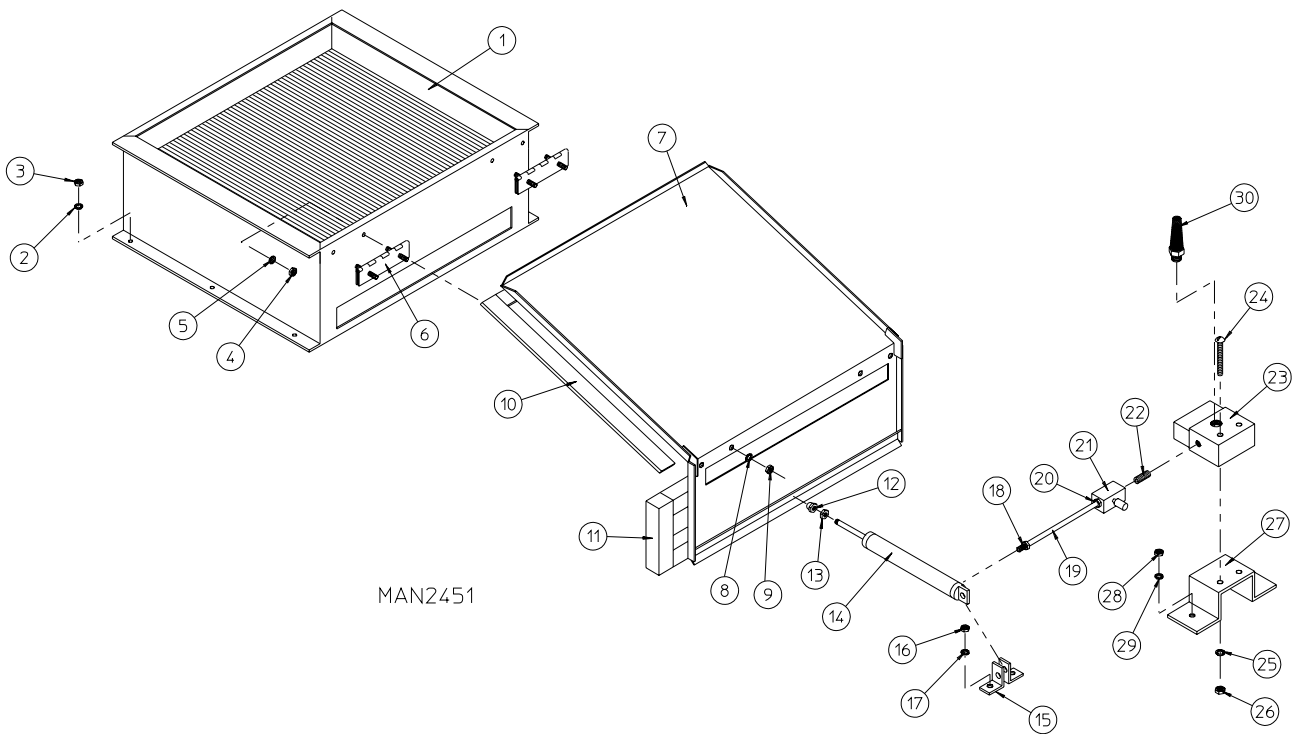

<u>Illus. No.</u>	<u>Part No.</u>	<u>Qty.</u>	<u>Description</u>
1	165008	1	ADS-30 Steam Coil Assembly
2	153002	6	5/16" Lock Washer
3	152004	6	5/16-18 Hex Nut
4	152002	4	1/4-20 Hex Nut
5	153007	4	1/4" Lock Washer
6	820321	2	ADS-30 Steam Damper Hinge Assembly
7	882079	1	ADS-30 Steam Damper Assembly (includes illus. nos. 7, 10, and 11) (for models mfd. as of August 2, 1998)
	803416	1	ADS-30 Steam Damper Assembly (includes illus. nos. 7, 10, and 11) (for models mfd. prior to August 2, 1998)
8	153007	4	1/4" Lock Washer
9	152002	4	1/4-20 Hex Nut
10	115995	60	Steam Damper Gasket (sold by the inch)
11	102350	1	Steam Damper Foam (68-1/2" length)
12	151006	1	5/16-24 Stainless Steel Acorn Nut
13	152051	1	5/16-24 Right Hand Jam Nut
14	100495	1	11/16" x 3" Stroke Piston
15	323365	2	Left and Right Piston Support
16	152002	2	1/4-20 Hex Nut
17	153007	2	1/4" Lock Washer
18	143163	1	1/4" x 1/8" Connector
19	143110	1	1/4" Tubing (sold by the foot)
20	143163	1	1/4" x 1/8" Connector
21	100496	1	1/8" Needle Valve
22	143238	1	1/8" Close Nipple
23	100498	1	3-Way Micro Valve - 24 VAC
24	150002	2	#6-32 x 1" Slotted Machine Screw
25	153010	2	#6 Star Washer
26	152000	2	#6-32 Hex Nut
27	330987	1	Micro Valve Support Bracket
28	152002	2	1/4-20 Hex Nut
29	153007	2	1/4" Lock Washer
30	100520	1	1/8" N.P.T. Silencer (muffler)

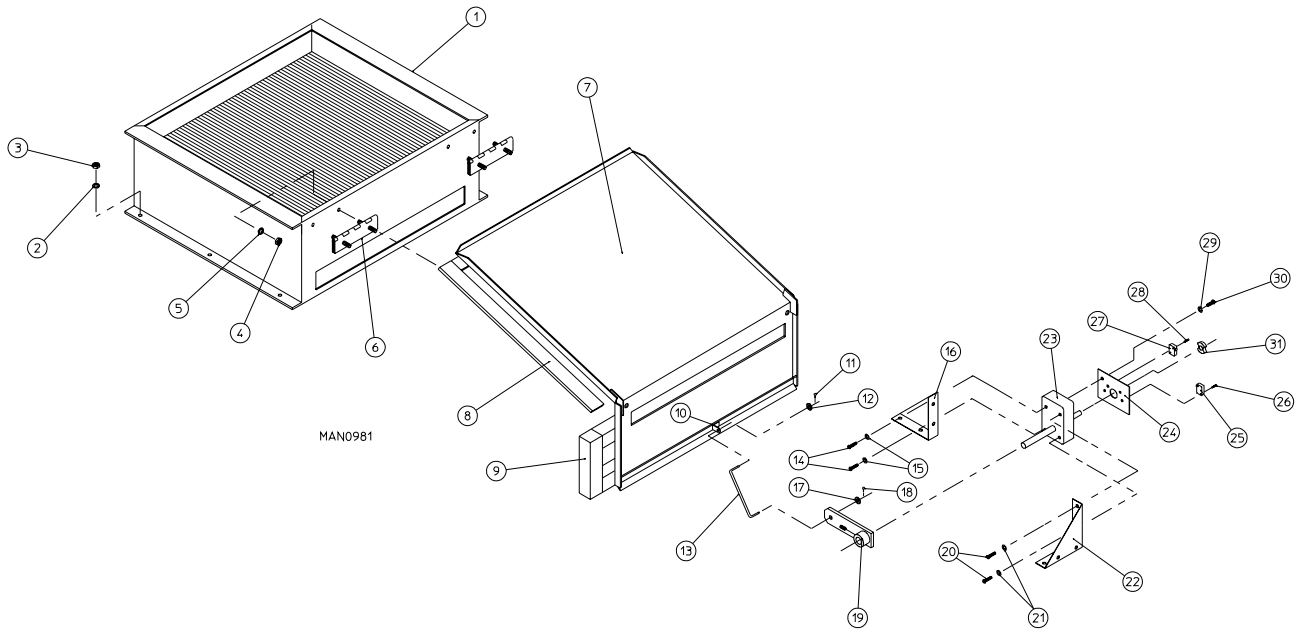

<u>Illus. No.</u>	<u>Part No.</u>	<u>Qty.</u>	<u>Description</u>
1	165008	1	ADS-30 Steam Coil Assembly
2	153002	6	5/16" Lock Washer
3	152004	6	5/16-18 Hex Nut
4	152002	4	1/4-20 Hex Nut
5	153007	4	1/4" Lock Washer
6	820321	2	ADS-30 Steam Damper Hinge Assembly
7	880780	1	ADS-30 Steam Damper Assembly (includes illus. nos. 7, 10, and 11)
8	115995	60	Steam Damper Gasket (sold by the inch)
9	102350	1	Steam Damper Foam (68-1/2" length)
10	309300	1	Rod Bracket
11	154300	1	1/2" x 3/32" Cotter Pin
12	153022	1	#10 Steel Burr
13	104052	1	Mechanical Steam Damper Actuator Rod
14	150110	2	#8-32 x 1/4" Phillips Head Machine Screw
15	153012	2	#8 Star Washer
16	312315	1	Mechanical Steam Damper Motor Mount
17	153022	1	#10 Steel Burr
18	154300	1	1/2" x 3/32" Cotter Pin
19	850268	1	Mechanical Steam Damper Arm
20	150110	2	#8-32 x 1/4" Phillips Head Machine Screw
21	153012	2	#8 Star Washer
22	312315	1	Mechanical Steam Damper Motor Mount
23	104054	1	Mechanical Steam Damper Motor
24	100511	1	Mechanical Steam Damper Switch Plate
25	122120	1	Mechanical Steam Damper Switch
26	150026	2	#4-40 x 5/8" Phillips Pan Head Machine Screw
27	122120	1	Mechanical Steam Damper Switch
28	150026	2	#4-40 x 5/8" Phillips Pan Head Machine Screw
29	153012	2	#8 Star Washer
30	150102	2	#8-32 x 3/8" Pan Head Machine Screw
31	-----*	1	Mechanical Steam Damper Motor Cam

* The mechanical steam damper motor cam is part of the mechanical steam damper motor.

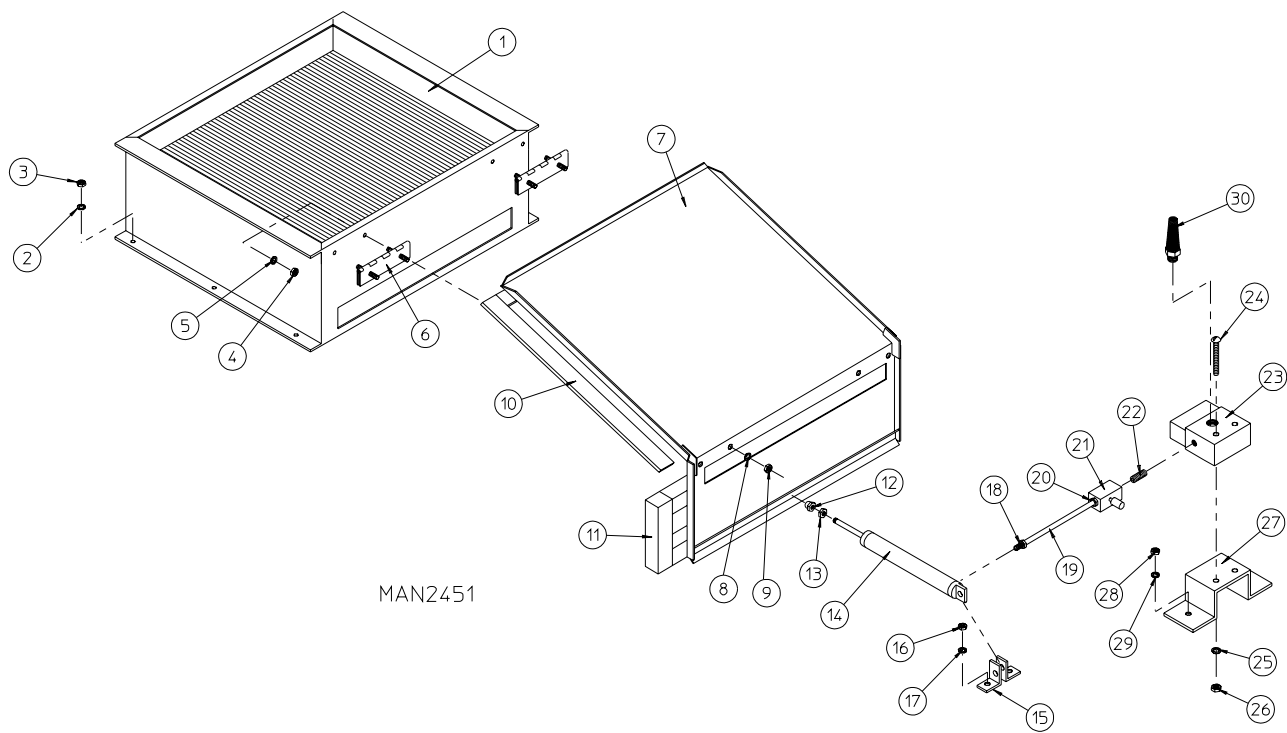

<u>Illus. No.</u>	<u>Part No.</u>	<u>Qty.</u>	<u>Description</u>
1	165011	1	ADS-50 Steam Coil Assembly
2	153002	6	5/16" Lock Washer
3	152004	6	5/16-18 Hex Nut
4	152002	4	1/4-20 Hex Nut
5	153007	4	1/4" Lock Washer
6	820321	2	ADS-50 Steam Damper Hinge Assembly
7	880280	1	ADS-50 Steam Damper Assembly (includes illus. nos. 7, 10, and 11) (for models mfd. as of July 27, 1998)
	803417	1	ADS-50 Steam Damper Assembly (includes illus. nos. 7, 10, and 11) (for models mfd. prior to July 27, 1998)
8	153007	4	1/4" Lock Washer
9	152002	4	1/4-20 Hex Nut
10	115995	60	Steam Damper Gasket (sold by the inch)
11	102350	1	Steam Damper Foam (68-1/2" length)
12	151006	1	5/16-24 Stainless Steel Acorn Nut
13	152051	1	5/16-24 Right Hand Jam Nut
14	100495	1	11/16" x 3" Stroke Piston
15	323365	2	Left and Right Piston Support
16	152002	2	1/4-20 Hex Nut
17	153007	2	1/4" Lock Washer
18	143163	1	1/4" x 1/8" Connector
19	143110	1	1/4" Tubing (sold by the foot)
20	143163	1	1/4" x 1/8" Connector
21	100496	1	1/8" Needle Valve
22	143238	1	1/8" Close Nipple
23	100498	1	3-Way Micro Valve - 24 VAC
24	150002	2	#6-32 x 1" Slotted Machine Screw
25	153010	2	#6 Star Washer
26	152000	2	#6-32 Hex Nut
27	330987	1	Micro Valve Support Bracket
28	152002	2	1/4-20 Hex Nut
29	153007	2	1/4" Lock Washer
30	100520	1	1/8" N.P.T. Silencer (muffler)

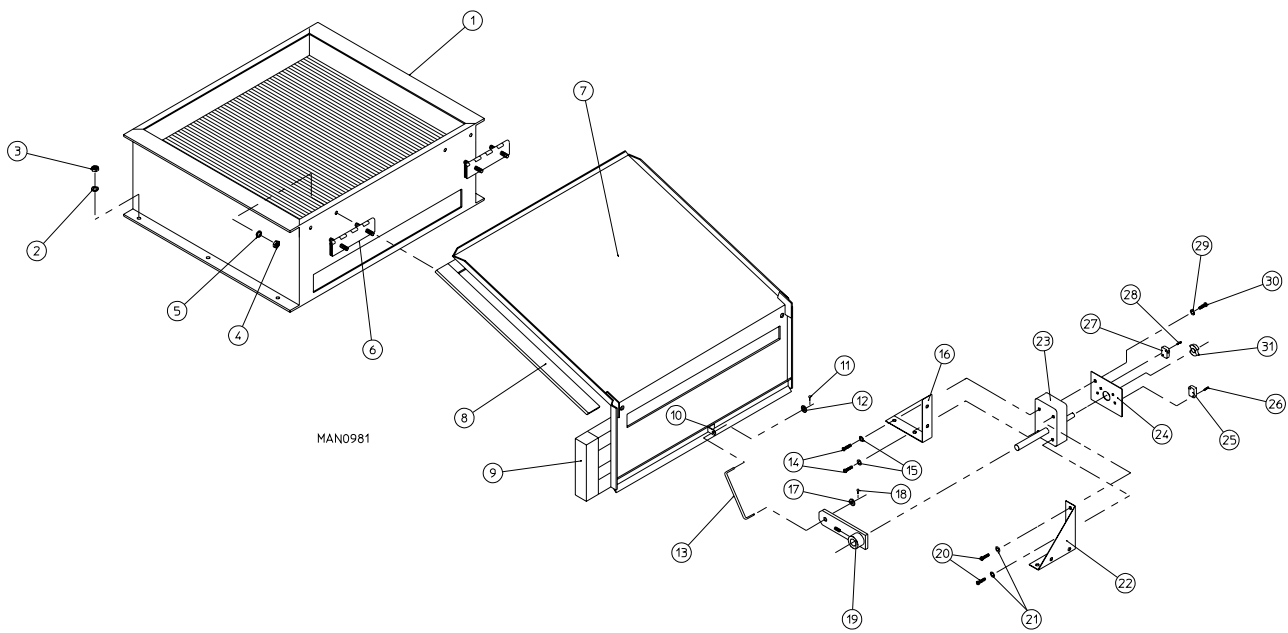

<u>Illus. No.</u>	<u>Part No.</u>	<u>Qty.</u>	<u>Description</u>
1	165011	1	ADS-50 Steam Coil Assembly
2	153002	6	5/16" Lock Washer
3	152004	6	5/16-18 Hex Nut
4	152002	4	1/4-20 Hex Nut
5	153007	4	1/4" Lock Washer
6	820321	2	ADS-50 Steam Damper Hinge Assembly
7	880781	1	ADS-50 Steam Damper Assembly (includes illus. nos. 7 through 10)
8	115995	66	Steam Damper Gasket (sold by the inch)
9	102350	1	Steam Damper Foam (68-1/2" length)
10	309300	1	Rod Bracket
11	154300	1	1/2" x 3/32" Cotter Pin
12	153022	1	#10 Steel Burr
13	104052	1	Mechanical Steam Damper Actuator Rod
14	150110	2	#8-32 x 1/4" Phillips Head Machine Screw
15	153012	2	#8 Star Washer
16	312315	1	Mechanical Steam Damper Motor Mount
17	153022	1	#10 Steel Burr
18	154300	1	1/2" x 3/32" Cotter Pin
19	850268	1	Mechanical Steam Damper Arm
20	150110	2	#8-32 x 1/4" Phillips Head Machine Screw
21	153012	2	#8 Star Washer
22	312315	1	Mechanical Steam Damper Motor Mount
23	104054	1	Mechanical Steam Damper Motor
24	100511	1	Mechanical Steam Damper Switch Plate
25	122120	1	Mechanical Steam Damper Switch
26	150026	2	#4-40 x 5/8" Phillips Pan Head Machine Screw
27	122120	1	Mechanical Steam Damper Switch
28	150026	2	#4-40 x 5/8" Phillips Pan Head Machine Screw
29	153012	2	#8 Star Washer
30	150102	2	#8-32 x 3/8" Pan Head Machine Screw
31	-----*	1	Mechanical Steam Damper Motor Cam

* The mechanical steam damper motor cam is part of the mechanical steam damper motor.

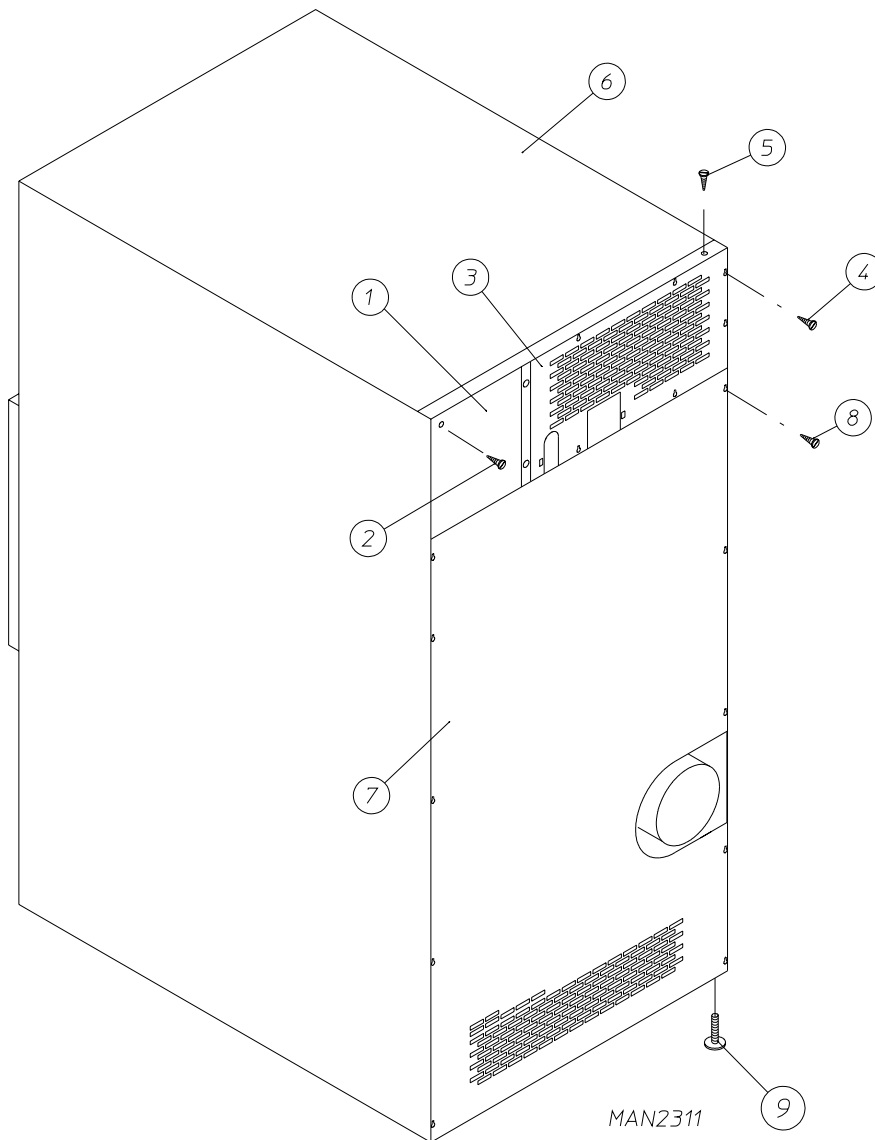

<u>Illus. No.</u>	<u>Part No.</u>	<u>Qty.</u>	<u>Description</u>
1	322809	1	Back Electrical Box Cover
2	150301	4	#8-18 x 7/16" Phillips Pan Head TEK Screw
3*	330077	1	AD-30 Top Back Guard
	314411	1	AD-50 Top Back Guard
4	150301	7	#8-18 x 7/16" Phillips Pan Head TEK Screw
5	150301	10	#8-18 x 7/16" Phillips Pan Head TEK Screw
6**	312510	1	AD-30 Outer Top
	312533	1	AD-50 Outer Top (for gas models Only)
	801577	1	AD-50 Outer Top (for electric models Only)
7	314513	1	AD-30 Bottom Back Guard
	314512	1	AD-50 Bottom Back Guard
8	150301	13	#8-18 x 7/16" Phillips Pan Head TEK Screw
9	103500	4	Leveling Leg

* There is no top back guard on gas heat reclaimer models and steam models.

** There is no outer top on gas heat reclaimer models and steam models.

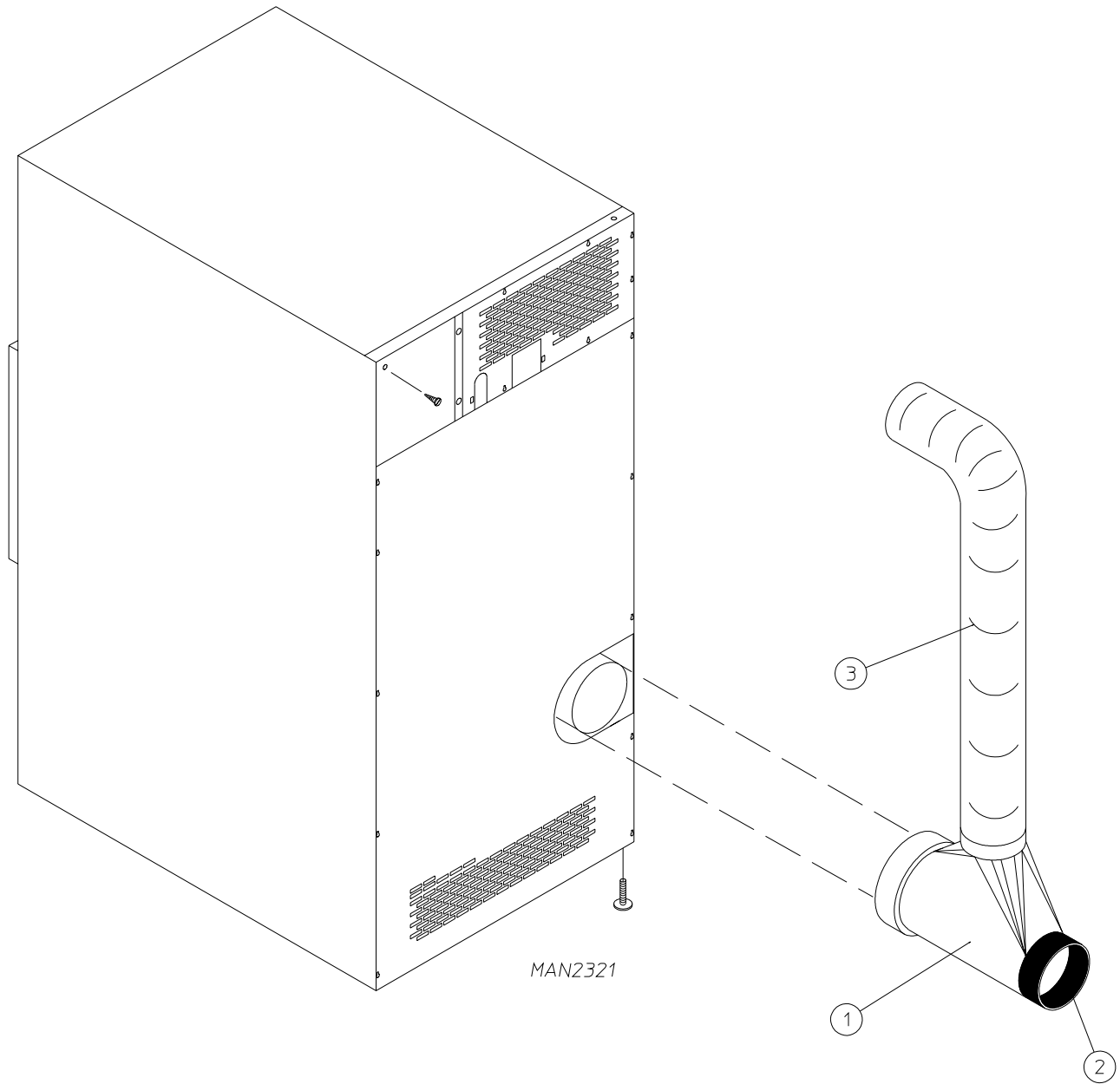

Illus. No.	Part No.	Qty.	Description
1	143501	1	8" x 6" x 6" Tee
2	880502	1	6" Replacement Damper
3	143509	1	6" Flexible Duct
--	117505	2	Aluminum Duct Tape (sold by the foot)

NOTE: Coin acceptors listed include optical switch (ADC Part No. 137056 Greenwald).
Coin acceptors listed include optical switch (ADC Part No. 881143 Hanke).

Single Coin*

<u>ADC Part No.</u>	<u>Nation</u>	<u>Description</u>
882689	United States	25¢ Hanke Optic Coin Acceptor (for models mfd. as of July 26, 2000)
125100	U.S. and Canada	25¢ Greenwald Optic Coin Acceptor (for models mfd. prior to July 26, 2000)
125107	Australia	20¢ Greenwald Australian Optic Coin Acceptor
881768	Australia	\$1 Hanke Australian Optic Coin Acceptor
881604	Japan	100 Yen Hanke Optic Coin Acceptor
125103	---	0.882 Greenwald Token Optic Coin Acceptor
125121	---	0.800 Greenwald Token Optic Coin Acceptor
125133	Hong Kong	\$1 Hong Kong Optic Coin Acceptor

Dual Coin*

<u>ADC Part No.</u>	<u>Nation</u>	<u>Description</u>
881508	U.S. and Canada	10¢/25¢ Hanke Dual Optic Coin Acceptor
881842	Canada	25¢/\$1 Hanke Dual Optic Coin Acceptor
881542	United Kingdom	1£/20 Pence Hanke Dual Optic Coin Acceptor
881846	France	2/5 French Franc Hanke Dual Optic Coin Acceptor
881541	Netherlands	25¢/1 Hanke Guilder Dual Optic Coin Acceptor

* Consult factory for coin acceptors not listed.

ADE-30 STEP DOWN TRANSFORMER USAGE LISTING					
Kw	VOLTAGE	PHASE	WIRE SERVICE	STEP DOWN TRANSFORMER PART NO.	CONTROL VOLTAGE PART NO.
30	208	3ø	3 or 4	-----	132070
30	240	3ø	3	-----	132070
30	416	3ø	3 or 4	132062	141403
30	460/480	3ø	3 or 4	132053	141403
25	380	3ø	3 or 4	132059	141403
24	208	3ø	3 or 4	-----	132070
24	240	3ø	3	-----	132070
24	416	3ø	3 or 4	132062	141403
24	460/480	3ø	3 or 4	132053	141403
20	208	1ø	2	-----	132070
20	240	1ø	2	-----	132070
20	380	3ø	3 or 4	132059	141403
15	208	3ø	3 or 4	-----	141403
15	240	3ø	3	-----	141403

ADE-50 STEP DOWN TRANSFORMER USAGE LISTING					
Kw	VOLTAGE	PHASE	WIRE SERVICE	STEP DOWN TRANSFORMER PART NO.	CONTROL VOLTAGE PART NO.
30	208	3ø	3 or 4	-----	132070
30	240	3ø	3	-----	132070
30	416	3ø	3 or 4	132062	141403
30	460/480	3ø	3 or 4	132053	141403
25	380	3ø	3 or 4	132059	141403
24	208	3ø	3 or 4	-----	132070
24	240	3ø	3	-----	132070
24	416	3ø	3 or 4	132062	141403
24	460/480	3ø	3 or 4	132053	141403
20	208	1ø	2	-----	132070
20	240	1ø	2	-----	132070
20	380	3ø	3 or 4	132059	141403

ADE-30 AND ADE-50				
HEAT	VOLTAGE	WIRE SERVICE	STEP DOWN TRANSFORMER PART NO.	CONTROL VOLTAGE PART NO.
<i>GAS</i> <i>STEAM</i>	208-240	3 or 4	-----	141403
	380	3	132059	141403
	380	4	132059	141403
	416	3	132062	141403
	416	4	132062	141403
	460/480	3	132053	141403
	460/480	4	132053	141403
	575	3	132050	141403

ADE-30

ht	Sliq^db	me^pb	t fob	I sbk=^ppvG	bihj bkq			I sbk=t fob			qboj fk^i ird		_rp=_^o mkW NONNAN	I sbk=Obi ^v	
					Qty	Kw	Part No.	Qty	Size	Part No.	Qty	Part No.		Cat. No.	Part No.
30	208	3ø	3 or 4	824917	6	5	120012	3	#4	133300	4	121012	1	FEAJ	131375
30	240	3ø	3	824934	6	5	120013	3	#4	133300	5	121012	1	DPA63	131369
30	416	3ø	3 or 4	824949	6	5	120012	4	#8	133100	5	121010	2	DPA43	131357
30	460 / 480	3ø	3 or 4	824955	6	5	120013	4	#8	133100	5	121010	2	BEAJ	131352
25	380	3ø	3 or 4	824942	6	5	120012	4	#8	133100	5	121010	2	BEAJ	131352
24	208	3ø	3 or 4	824919	6	4	120010	3	#4	133300	4	121012	1	DPA63	131369
24	240	3ø	3	824936	6	4	120011	3	#6	133200	4	121012	1	DEAJ	131365
24	416	3ø	3 or 4	824948	6	4	120010	4	#8	133100	5	121010	2	BEAJ	131352
24	460 / 480	3ø	3 or 4	824954	6	4	120011	4	#10	133000	5	121010	2	BEAJ	131352
20	208	1ø	2	824906	5	4	120010	2	#4	133300	2	11010	2	GEAJ	131385
20	240	1ø	2	824928	5	4	120011	2	#4	133300	2	121010	2	FEAJ	131375
20	380	3ø	3 or 4	824941	6	4	120010	4	#10	133300	5	121010	2	BEAJ	131352
15	208	3ø	3 or 4	824913	3	5	120012	3	#8	133100	4	121010	2	DPA43	131357
15	240	3ø	3	824930	3	5	120013	3	#8	133100	4	121010	2	BEAJ	131352

* Oven assemblies **DO NOT** include oven relay (contactor). This item **must be** ordered separately. When ordering oven assembly complete, specify 3 or 4 wire when applicable as well as if dryer has microprocessor controls.

N/A = Not available.

ADE-50

ht	Sliq^db	me^pb	t fob	I sbk=^ppvG	bihj bkq			I sbk=t fob			qboj fk^i ird		_rp=_^o mkW NONNAN	I sbk=Obi ^v	
					Qty	Kw	Part No.	Qty	Size	Part No.	Qty	Part No.		Cat. No.	Part No.
30	208	3ø	3 or 4	824917	6	5	120012	3	#4	133300	4	121012	1	FEAJ	131375
30	240	3ø	3	824934	6	5	120013	3	#4	133300	5	121012	1	DPA63	131369
30	416	3ø	3 or 4	824949	6	5	120012	4	#8	133100	5	121010	2	DPA43	131357
30	460 / 480	3ø	3 or 4	824955	6	5	120013	4	#8	133100	5	121010	2	BEAJ	131352
25	380	3ø	3 or 4	824942	6	5	120012	4	#8	133100	5	121010	2	BEAJ	131352
24	208	3ø	3 or 4	824919	6	4	120010	3	#4	133300	4	121012	1	DPA63	131369
24	240	3ø	3	824936	6	4	120011	3	#6	133200	4	121012	1	DEAJ	131365
24	416	3ø	3 or 4	824948	6	4	120010	4	#8	133100	5	121010	2	BEAJ	131352
24	460 / 480	3ø	3 or 4	824954	6	4	120011	4	#10	133000	5	121010	2	BEAJ	131352
20	208	1ø	2	824904	5	4	120010	2	#4	133300	2	11010	2	GEAJ	131385
20	240	1ø	2	824928	5	4	120011	2	#4	133300	2	121010	2	FEAJ	131375
20	380	3ø	3 or 4	824941	6	4	120010	4	#10	133300	5	121010	2	BEAJ	131352

* Oven assemblies **DO NOT** include oven relay (contactor). This item **must be** ordered separately. When ordering oven assembly complete, specify 3 or 4 wire when applicable as well as if dryer has microprocessor controls.

N/A = Not available.

84 ADG-30/ADG-50 Direct Spark Ignition (DSI) Burner Assembly Specifications

DSI BURNER ORIFICE LISTING*

ADC MODEL NUMBER	HEAT RECLAIMER	QTY.	NATURAL GAS		L.P. GAS	
			D.M.S.	PART No.	D.M.S.	PART No.
ADG-30D	No	2	#30	140819	#46	140806
ADG-30DH	Yes	2	1/8"	140843	#49	140803
ADG-50D	No	2	#21	140827	#43	140809
ADG-50DH	Yes	2	#26	140823	#43	140809

* Consult factory for elevations over 2,000 feet.

DSI BURNER ASSEMBLY LISTING

ADC MODEL NUMBER	HEAT RECLAIMER	NATURAL GAS PART NUMBER	L.P. GAS PART NUMBER
ADG-30D	No	809631	809632
ADG-30DH	Yes	809633	809634
ADG-50D	No	809625	809626
ADG-50DH	Yes	809624	809624
NOTES: 1. Burner assemblies <i>do not include</i> burner orifices. They must be ordered separately. 2. When ordering burner assemblies, specify model number and if computer or non-computer.			
ADG-30D*	No	809725	809726
ADG-50D*	No	809700	809701
ADG-50DH*	Yes	809702	809703
NOTE: *Models manufactured as of April 10, 2000			

DSI L.P. CONVERSION KIT LISTING*

<i>^a`j l abi =krj _bo</i>	<i>hfq=m^oq=krj _bo</i>
ADG-30D	874050
ADG-30DH	874049
ADG-50D	874044
ADG-50DH	874045

* Consult factory for elevations over 2,000 feet.

<u>Part No.</u>	<u>Description</u>
114006	“WARNING - Fire Hazards” Label
112280	“Clean Lint Screen” Label
114001	“CAUTION Exhaust/Lint Screen” Label
112533	“Phase 5 Coin Program Location Summary” Label
112534	“Phase 5 OPL Program Location Summary” Label
120100	3/8” Straight (BX) Connector
120300	3/8” x 45° (BX) Connector
120400	3/8” Red Jacket (BX) Insulator
120500	3/8” Jiffy Clip (BX retainer clip)
120600	3/8” Greenfield (BX)
120707	Terminal Strip (2-position)
120708	Terminal Strip (3-position)
120800	1/4” In-Line Connector
120802	Red Butt Connector
120902	#74B Wire Nut
120903	Crimp-On Wire Nut
121014	1/4” Insulated (female) Terminal
121026	Tab Receptacle Combination
121499	5-1/2” Harness Tie
121500	8” Harness Tie
121503	Harness Tie Mounting Clip
122804	Manometer (hydro gauge) for Measuring Gas Pressure
404500	Almond Brush-In-Cap Bottle Touch-Up Paint
404502	White Brush-In-Cap Bottle Touch-Up Paint
404506	Beige Brush-In-Cap Bottle Touch-Up Paint
404507	Cornflower Blue Brush-In-Cap Bottle Touch-Up Paint

ADC 450103 1 - 10/08/92-250 2 * 09/25/92-250 3 * 02/08/93-100
4 - 03/18/93-250 5 * 08/25/93-250 6 - 01/05/94-100
7 * 03/21/94-100 8 * 04/08/94-250 9 * 08/23/94-100
10 - 11/29/94-200 11 * 03/02/95-200 12 * 07/10/95-200
13 * 09/28/95-200 14 * 12/04/95-200 15 * 03/25/96-250
16 * 02/12/97-250 17 * 07/18/97-250 18 - 02/24/98-87
19 * 07/30/98-163 20 * 09/04/98-139 21 * 02/03/00-200
22 - 09/26/00-75 23 * 09/28/01-25 24 - 12/03/01-10
25 * 12/21/01-25 26 * 11/22/02-25 27 - 02/25/03-10
28 - 09/10/03-5

