



# **AD-200 Non-Tilt Parts Manual 24 VAC Phase 5 1992 thru 1997**

---

**American Dryer Corporation**  
88 Currant Road  
Fall River MA 02720-4781  
Telephone: (508) 678-9010 / Fax: (508) 678-9447  
E-mail: [service@amdry.com](mailto:service@amdry.com)

# Retain This Manual In A Safe Place For Future Reference

American Dryer Corporation products embody advanced concepts in engineering, design, and safety. If this product is properly maintained, it will provide many years of safe, efficient, and trouble-free operation.

*ONLY properly licensed technicians should service this equipment.*

**OBSERVE ALL SAFETY PRECAUTIONS** displayed on the equipment or specified in the installation/operator's manual included with the dryer.

**WARNING: UNDER NO CIRCUMSTANCES should the door switch or the heat circuit devices ever be disabled.**

**WARNING: The dryer must never be operated with any of the back guards, outer tops, or service panels removed. PERSONAL INJURY or FIRE COULD RESULT.**

We have tried to make this manual as complete as possible and hope you will find it useful. ADC reserves the right to make changes from time to time, without notice or obligation, in prices, specifications, colors, and material, and to change or discontinue models.

## Important

For your convenience, log the following information:

DATE OF PURCHASE \_\_\_\_\_ MODEL NO. AD-200 Non-Tilt

DISTRIBUTORS NAME \_\_\_\_\_

Serial Number(s) \_\_\_\_\_

\_\_\_\_\_

\_\_\_\_\_

Replacement parts can be obtained from your distributor or the ADC factory. When ordering replacement parts from the factory, you can FAX your order to ADC at (508) 678-9447 or telephone your orders directly to the ADC Parts Department at (508) 678-9010. Please specify the dryer **model number** and **serial number** in addition to the **description** and **part number**, so that your order is processed accurately and promptly.

The illustrations on the following pages may not depict your particular dryer exactly. The illustrations are a composite of the various dryer models. Be sure to check the descriptions of the parts thoroughly before ordering.

INSTRUCTIONS TO BE FOLLOWED IN THE EVENT THE USER SMELLS GAS MUST BE POSTED IN A PROMINENT LOCATION. THE INSTRUCTIONS TO BE POSTED SHALL BE OBTAINED FROM THE LOCAL GAS SUPPLIER.

# Table of Contents

AD-200 Front Panel Assembly - <i>Automatic Door</i> .....	2, 3
AD-200 Front Panel Assembly - <i>Manual Door</i> .....	4, 5
Left and Right Control Door Assemblies - <b>for models mfd. as of April 4, 1996</b> .....	6, 7
Left and Right Control Door Assemblies - <b>for models mfd. prior to April 4, 1996</b> .....	8, 9
Left Load Door Assembly - <i>Automatic Door</i> .....	10, 11
Right Load Door Assembly - <i>Automatic Door</i> .....	12, 13
Left Load Door Assembly - <i>Manual Door</i> - <b>for models mfd. as of November 1, 1995</b> .....	14, 15
Right Load Door Assembly - <i>Manual Door</i> - <b>for models mfd. as of November 1, 1995</b> .....	16, 17
Left Load Door Assembly - <i>Manual Door</i> - <b>for models mfd. prior to November 1, 1995</b> .....	18, 19
Right Load Door Assembly - <i>Manual Door</i> - <b>for models mfd. prior to November 1, 1995</b> .....	20, 21
Pneumatics Assembly - <i>Automatic Door</i> .....	22
Magnetic Door Switch Assembly .....	23
ADG-200 Left Hand Control Panel Assembly - <b>for Gas Models mfd. with Thermal-Magnetic Protection ONLY</b> <b>for Gas Models mfd. as of October 2, 1995</b> .....	24, 25
ADS-200 Left Hand Control Panel Assembly - <b>for Steam Models mfd. with Thermal-Magnetic Protection ONLY</b> <b>for Steam Models mfd. as of October 19, 1995</b> .....	26, 27
ADG-200 Left Hand Control Panel Assembly - <b>for Gas Models mfd. with Fuse Protection ONLY</b> <b>for Gas Models mfd. prior to October 2, 1995</b> .....	28, 29
ADS-200 Left Hand Control Panel Assembly - <b>for Steam Models mfd. with Fuse Protection ONLY</b> <b>for Steam Models mfd. prior to October 19, 1995</b> .....	30, 31
Right Hand Control Panel Assembly - <i>Automatic Door</i> .....	32, 33
Right Hand Control Panel Assembly - <i>Manual Door</i> .....	34
Side Panel Assemblies .....	35
Back Panel Assemblies .....	36
Tumbler and Idler Shaft Assembly .....	37
Drive Shaft Assembly .....	38
Tumbler Retaining Wheel Assembly .....	39
Lint Drawer/Basket Assembly .....	40
Temperature Sensor Bracket Assembly .....	41
Drive Motor Assembly .....	42, 43
ADG-200 Blower Assembly - <b>for Gas Models ONLY</b> .....	44, 45
ADS-200 Blower Assembly - <b>for Steam Models ONLY</b> .....	46, 47
ADG-200 Gas Burner Assembly .....	48, 49
DSI Module Assembly - <b>for Gas Models ONLY</b> .....	50
Sail Switch Assembly .....	51
ADS-200 Steam Coil Assembly .....	52, 53
Sprinkler Control Panel Assembly .....	54, 55
Sprinkler Piping Assembly .....	56, 57
Sprinkler Temperature Probe Junction Box Assembly .....	58
Pneumatic Assembly - <b>2 Automatic Doors</b> .....	59
AD-200 Air Jet Assembly .....	60
Filter/Regulator/Lubricator Assembly .....	61
End of Cycle Light Assembly .....	62
AD-200 Rotational Sensor Assembly .....	63
Back Guard Assembly .....	64
AD-200 Overload/Contactor Chart .....	65
Transformer Usage Listing .....	66

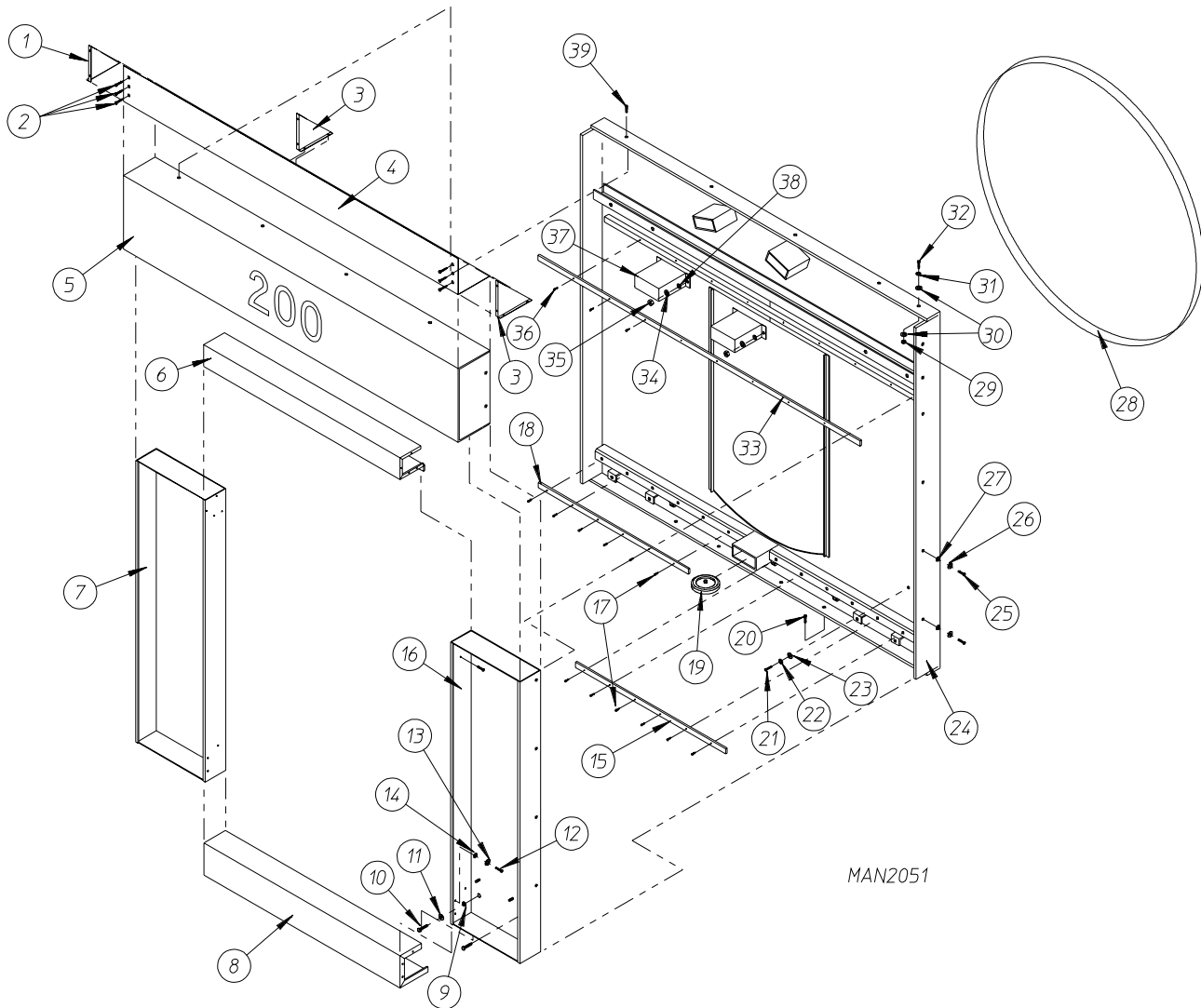

**AUTOMATIC DOOR**

<u>Illus. No.</u>	<u>Part No.</u>	<u>Qty.</u>	<u>Description</u>
1	332680	1	Left Gusset (for Gas Models ONLY)
2	150522	15	1/4-20 x 1/2" Hex Washer TEK Screw (for Gas Models ONLY)
3	332681	2	Right Gusset (for Gas Models ONLY)
4*	332679	1	Top Front Panel (for Gas Models ONLY)
5*	821241	1	Upper Guard
6*	821239	1	Middle Guard
7*	881117	1	Left Control Cabinet
8*	821285	1	Bottom Guard
9	153001	8	5/16" Flat Washer
10	150501	8	5/16-18 x 3/4" Hex Head Machine Bolt
11	153002	8	5/16" Lock Washer
12	150510	12	1/4-20 x 3/4" Hex Head Machine Bolt
13	153007	12	1/4" Lock Washer
14	153018	12	1/4" Flat Washer
15	170364	1	Bottom Door Track
16*	881116	1	Right Control Cabinet
17	154312	14	#10-32 x 3/4" Socket Head Cap Screw
18	170364	1	Bottom Door Track
19	-----	--	Tumbler Retaining Wheel (refer to <b>Tumbler Retaining Wheel Assembly</b> on <b>page 39</b> )
20	150523	5	1/4-20 x 3/4" Hex Washer Machine Bolt
21	150617	8	3/8-16 x 1" Hex Head Bolt
22	153005	8	3/8" Lock Washer
23	153004	8	3/8" Flat Washer
24*	881109	1	Front Panel Assembly
25	150501	12	5/16-18 x 3/4" Hex Head Machine Bolt
26	153002	12	5/16" Lock Washer
27	153001	12	5/16" Flat Washer
28	115998	180	AD-200 Tumbler Ring Felt (sold by the inch)
29	152011	4	1/2-13 Hex Nut
30	153050	8	1/2" x 1-1/16" Flat Washer
31	153026	4	1/2" Lock Washer
32	150605	4	1/2-13 x 1-1/2" Hex Head Bolt
33	170365	1	Upper Door Track
34	153007	12	1/4" Lock Washer
35	152002	12	1/4-20 Hex Nut
36	154312	15	#10-32 x 3/4" Socket Head Cap Screw
37*	821244	2	Tumbler Retaining Wheel Cover
38	153018	12	1/4" Flat Washer
39	150523	5	1/4-20 x 3/4" Hex Washer Machine Bolt

\* Specify color when ordering.

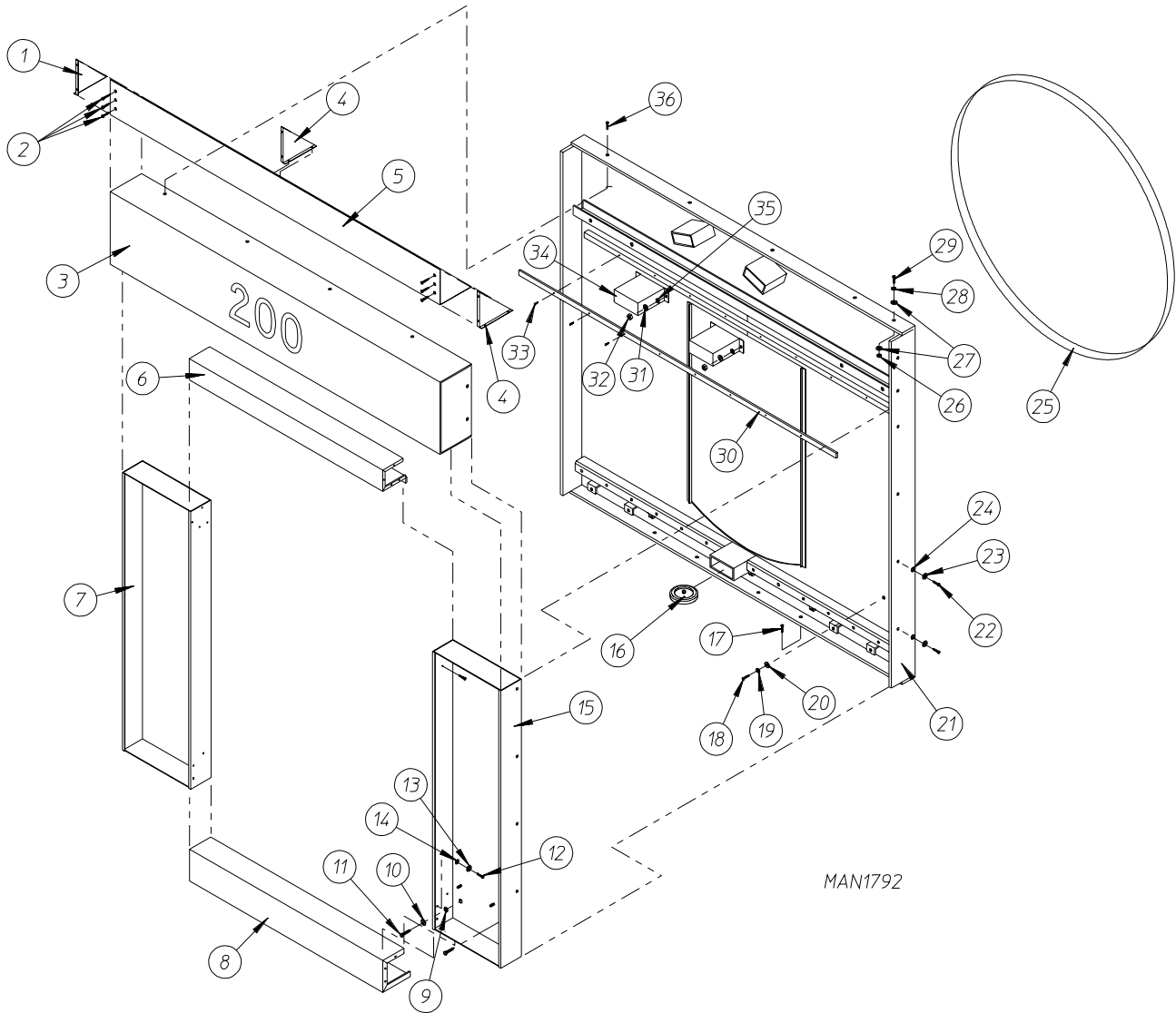

**MANUAL DOOR**

<u>Illus. No.</u>	<u>Part No.</u>	<u>Qty.</u>	<u>Description</u>
1	332680	1	Left Gusset (for Gas Models ONLY)
2	150522	15	1/4-20 x 1/2" Hex Washer TEK Screw (for Gas Models ONLY)
3*	821241	1	Upper Guard
4	332681	2	Right Gusset (for Gas Models ONLY)
5*	332679	1	Top Front Panel (for Gas Models ONLY)
6*	821239	1	Middle Guard
7*	881117	1	Left Control Cabinet
8*	821285	1	Bottom Guard
9	153001	8	5/16" Flat Washer
10	153002	8	5/16" Lock Washer
11	150501	8	5/16-18 x 3/4" Hex Head Machine Bolt
12	150510	12	1/4-20 x 3/4" Hex Head Machine Bolt
13	153007	12	1/4" Lock Washer
14	153018	12	1/4" Flat Washer
15*	881116	1	Right Control Cabinet
16	-----	--	Tumbler Retaining Wheel (refer to <b>Tumbler Retaining Wheel Assembly</b> on <b>page 39</b> )
17	150523	5	1/4-20 x 3/4" Hex Washer Machine Bolt
18	150617	8	3/8-16 x 1" Hex Head Bolt
19	153005	8	3/8" Lock Washer
20	153004	8	3/8" Flat Washer
21*	881108	1	Front Panel Assembly
22	150501	12	5/16-18 x 3/4" Hex Head Machine Bolt
23	153002	12	5/16" Lock Washer
24	153001	12	5/16" Flat Washer
25	115998	180	AD-200 Tumbler Ring Felt (sold by the inch)
26	152011	4	1/2-13 Hex Nut
27	153050	8	1/2" x 1-1/16" Flat Washer
28	153026	4	1/2" Lock Washer
29	150605	4	1/2-13 x 1-1/2" Hex Head Bolt
30	170365	1	Upper Door Track
31	153007	12	1/4" Lock Washer
32	152002	12	1/4-20 Hex Nut
33	154312	15	#10-32 x 3/4" Socket Head Cap Screw
34*	821244	2	Tumbler Retaining Wheel Cover
35	153018	12	1/4" Flat Washer

\* Specify color when ordering.

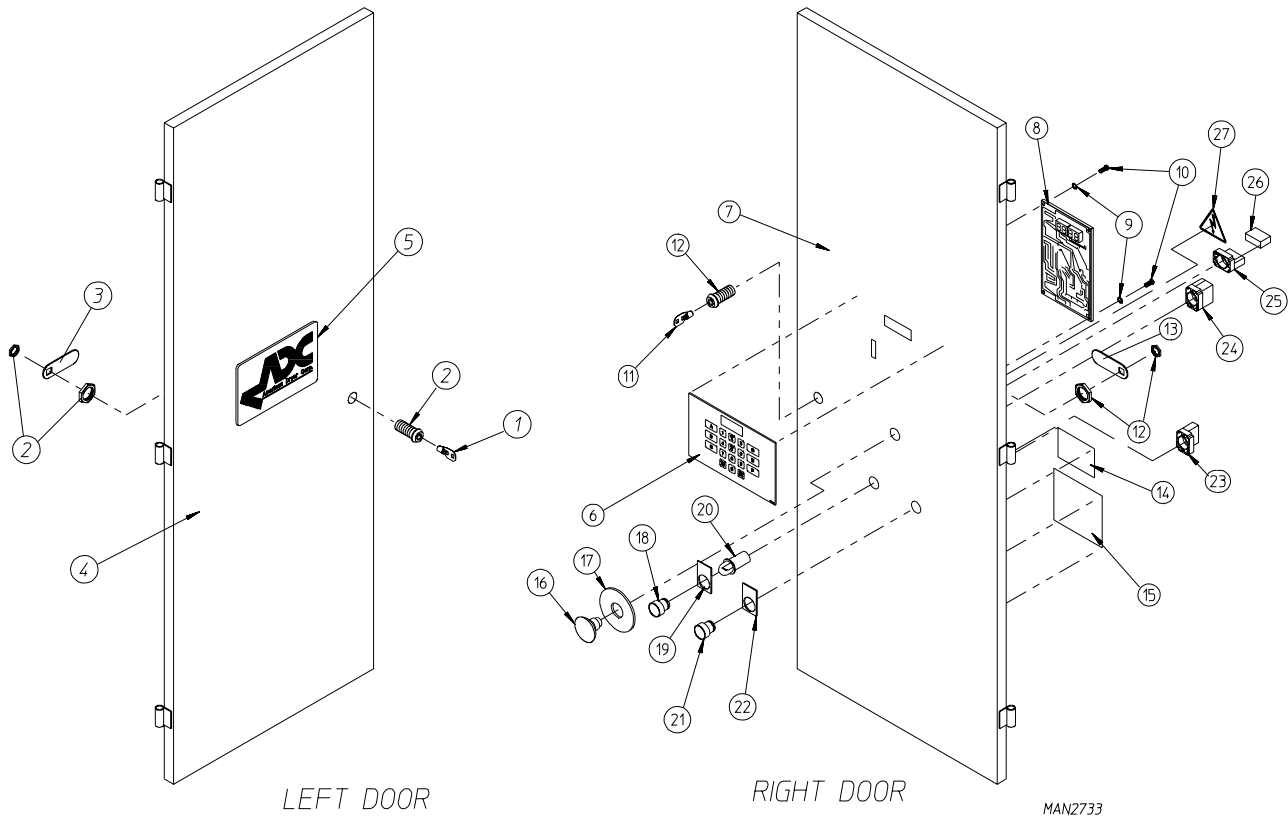



---

**for models mfd. as of April 4, 1996**

<u>Illus. No.</u>	<u>Part No.</u>	<u>Qty.</u>	<u>Description</u>
1	160140	1	ACE® XX4451 Key ONLY
2	160050	1	ACE® Control Door Lock ONLY less Key (keyed to #XX4451)
3	160014	1	Cam ONLY
4	821334	1	Left Hand Control Door Assembly
5*	112360	1	<b>ADC</b> Logo ONLY (Tape Kit not included)
	870011	1	Logo Double Tape Kit
6	112535	1	OPL English Keyboard Label Assembly
7*	821739	1	Right Hand Control Door Assembly (includes illus. nos. 7, 9, and 10)
8	137225	1	Phase 5 OPL Reversing Controller with Air Jet
9	153010	2	#6 Star Washer
10	150005	2	#6-32 x 1/4" Phillips Round Head Machine Screw
11	160140	1	ACE® XX4451 Key ONLY
12	160050	1	ACE® Control Door Lock ONLY less Key (keyed to #XX4451)
13	160014	1	Cam ONLY
14	112095	1	"Phase 5 Computer System" Label
15	112534	1	"Phase 5 Program Location" Label
16	122351	1	Large "EMERGENCY STOP" (Mushroom Head) Button
17	122419	1	"EMERGENCY STOP" Nameplate
18	123201	1	Green "CONTROL VOLTAGE ON" Button
19	122410	1	Power "ON" Nameplate
20	123212	1	24 VAC Incandescent Bulb
21	123204	1	Red "CONTROL VOLTAGE OFF" Button
22	122421	1	Power "OFF" Nameplate
23	132395	1	Mounting Base with 1 Normally Closed (N.C.) Contact Block
24	132388	1	Normally Open (N.O.) Contact Block with Direct Supply
25	132395	1	Mounting Base with 1 Normally Closed (N.C.) Contact Block
26	132387	1	Normally Closed (N.C.) Contact Block
27	122424	1	Power Warning Label "Small Triangle"

\* Specify color when ordering.

**for models mfd. prior to April 4, 1996**

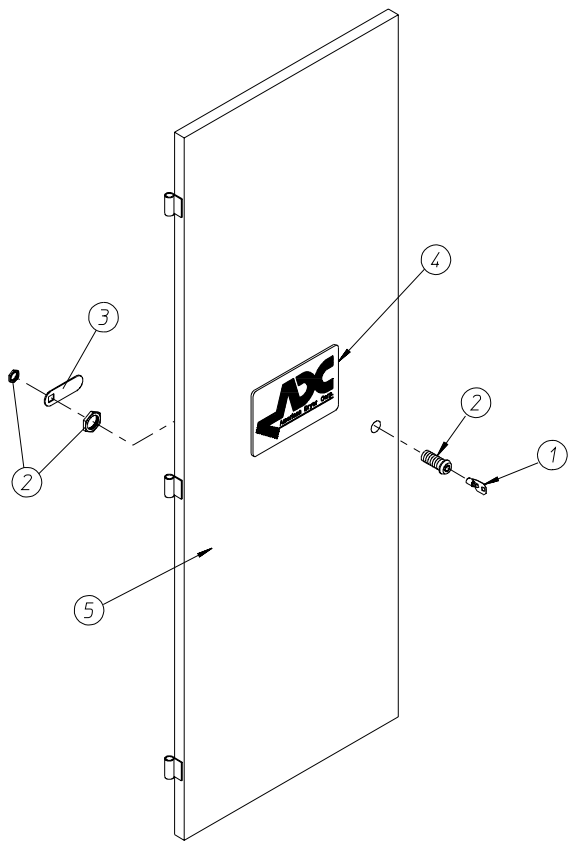

LEFT DOOR

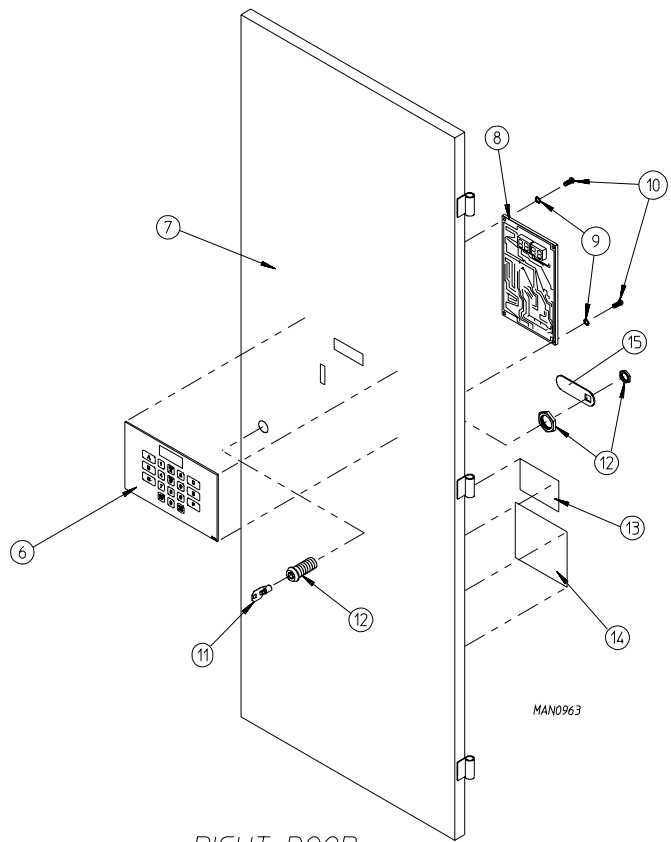

RIGHT DOOR

MAN0963

**for models mfd. prior to April 4, 1996**

---

<u>Illus. No.</u>	<u>Part No.</u>	<u>Qty.</u>	<u>Description</u>
1	160140	1	ACE® XX4451 Key ONLY
2	160050	1	ACE® Control Door Lock ONLY less Key (keyed to #XX4451) For models mfd. as of July 20, 1992
	160038	1	ACE® Control Door Lock ONLY less Key (keyed to #XX4451) For models mfd. prior to July 20, 1992
3	160014	1	Cam ONLY
4	112360	1	<b>ADC</b> Logo ONLY (Tape Kit not included)
	870011	1	Logo Double Tape Kit
5*	821334	1	Left Hand Control Door Assembly (for models mfd. as of July 20, 1992)
	821228	1	Left Hand Control Door Assembly (for models mfd. prior to July 20, 1992)
6	112535	1	OPL English Keyboard Label Assembly
7*	821440	1	Right Hand Control Door Assembly (includes illus. nos. 7, 9, and 10) For models mfd. as of July 20, 1992
	821327	1	Right Hand Control Door assembly (includes illus. nos. 7, 9, and 10) For models mfd. prior to July 20, 1992
8	137225	1	Phase 5 OPL Reversing Controller with Air Jet
9	153010	2	#6 Star Washer
10	150005	2	#6-32 x 1/4" Phillips Round Head Machine Screw
11	160140	1	ACE® XX4451 Key ONLY
12	160050	1	ACE® Control Door Lock ONLY less Key (keyed to #XX4451) For models mfd. as of July 20, 1992
	160038	1	ACE® Control Door Lock ONLY less Key (keyed to #XX4451) For models mfd. prior to July 20, 1992
13	112095	1	"Phase 5 Computer System" Label
14	112534	1	"Phase 5 Program Location" Label
15	160014	1	Cam ONLY

\* Specify color when ordering.

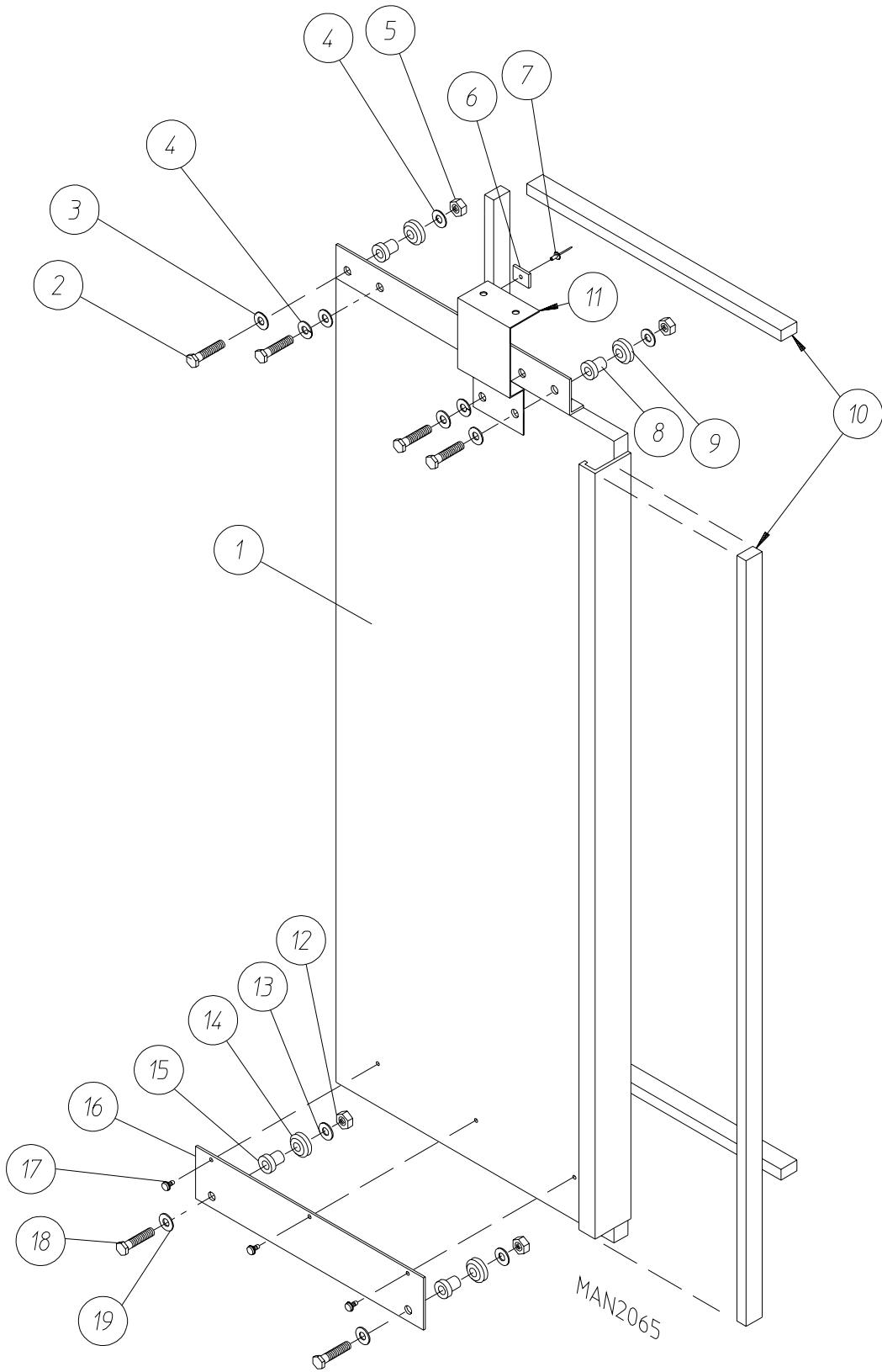

**AUTOMATIC DOOR**

<u>Illus. No.</u>	<u>Part No.</u>	<u>Qty.</u>	<u>Description</u>
1*	881112	1	Left Automatic Load Door Assembly Complete (includes illus. nos. 1 through 11)
	881106	1	Left Automatic Load Door ONLY
2	150112	4	1/4-20 x 1-1/4" Hex Head Machine Screw
3	153018	4	1/4" Flat Washer
4	153007	4	1/4" Lock Washer
5	152002	2	#1/4-20 Hex Nut
6	102102	1	Door Magnet
7	154200	1	5/32" Pop Rivet
8	170367	2	Stainless Steel Stationary Bushing
9	170366	2	Stainless Steel Sealed Wheel
10	115995	125	Felt Gasket (sold by the inch)
11*	334134	1	Automatic Door Bracket
12	152002	2	1/4-20 Hex Nut
13	153007	2	1/4" Lock Washer
14	170366	2	Stainless Steel Sealed Wheel
15	170367	2	Stainless Steel Stationary Bushing
16*	881133	1	Lower Trolley Assembly Complete (includes illus. nos. 12 through 16, 18, and 19)
	334123	1	Lower Trolley ONLY
17	150301	3	#8-18 x 7/16" Phillips Pan Head TEK Screw
18	150112	2	1/4-20 x 1-1/4" Hex Head Machine Screw
19	153018	2	1/4" Flat Washer

\* Specify color when ordering.

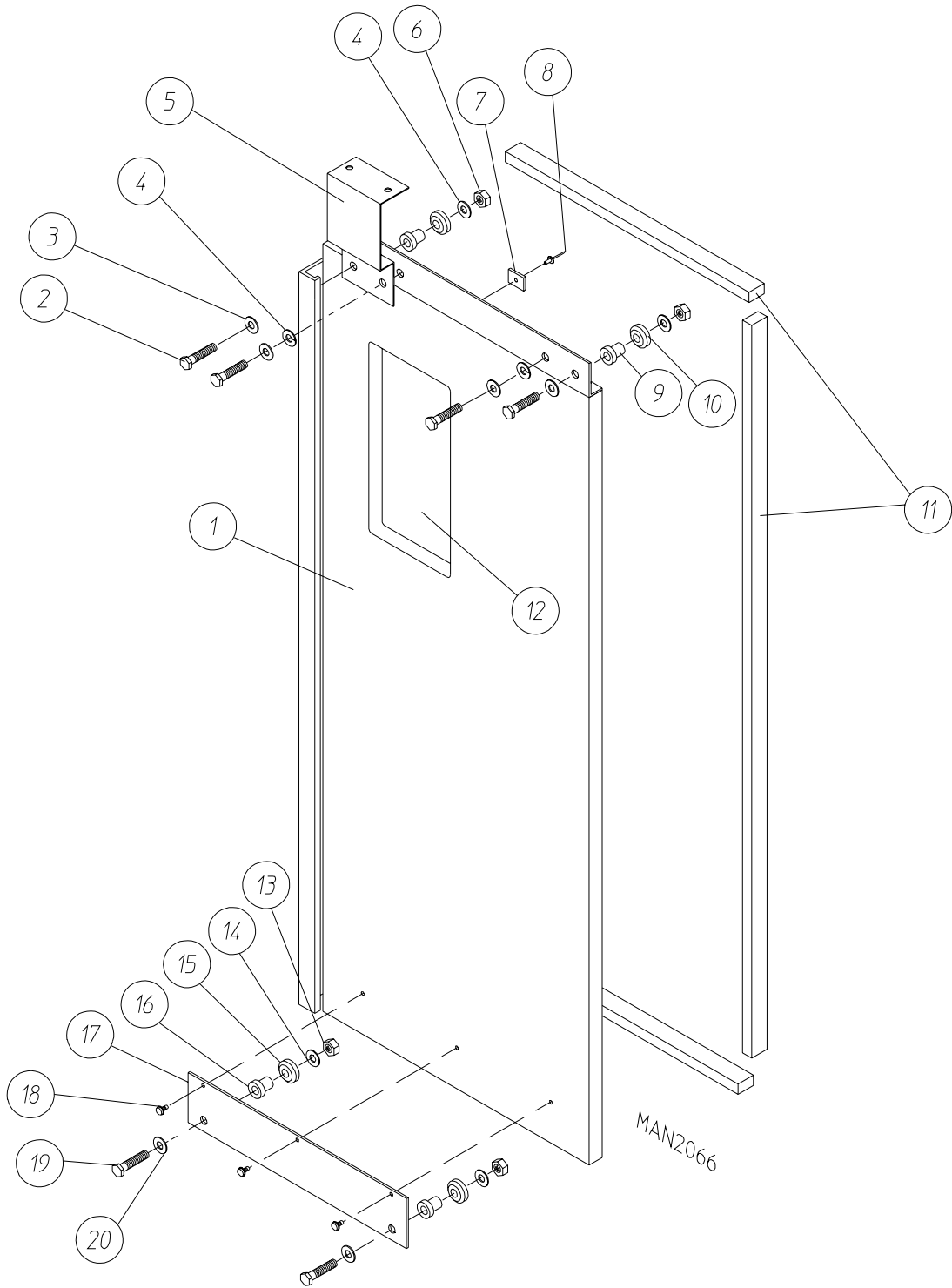

**AUTOMATIC DOOR**

<u>Illus. No.</u>	<u>Part No.</u>	<u>Qty.</u>	<u>Description</u>
1*	881113	1	Right Automatic Load Door Assembly Complete (includes illus. nos. 1 through 12)
	881107	1	Right Automatic Load Door ONLY
2	150112	4	1/4-20 x 1-1/4" Hex Head Machine Screw
3	153018	4	1/4" Flat Washer
4	153007	4	1/4" Lock Washer
5*	334134	1	Automatic Door Bracket
6	152002	2	1/4-20 Hex Nut
7	102102	1	Door Magnet
8	154200	1	5/32" Pop Rivet
9	170367	2	Stainless Steel Stationary Bushing
10	170366	2	Stainless Steel Sealed Wheel
11	115995	80	Felt Gasket (sold by the inch)
12	102215	1	Door Window
	170730	-	Door Window Adhesive (10.3 oz. cartridge)
13	152002	2	1/4-20 Hex Nut
14	153007	2	1/4" Lock Washer
15	170366	2	Stainless Steel Sealed Wheel
16	170367	2	Stainless Steel Stationary Bushing
17*	881133	1	Lower Trolley Assembly Complete (includes illus. nos. 13 through 17, 19, and 20)
	334123	1	Lower Trolley ONLY
18	150301	3	#8-18 x 7/16" Phillips Pan Head TEK Screw
19	152112	2	1/4-20 x 1-1/4" Hex Head Machine Screw
20	153018	2	1/4" Flat Washer

\* Specify color when ordering.

**MANUAL DOOR**  
for models mfd. as of November 1, 1995

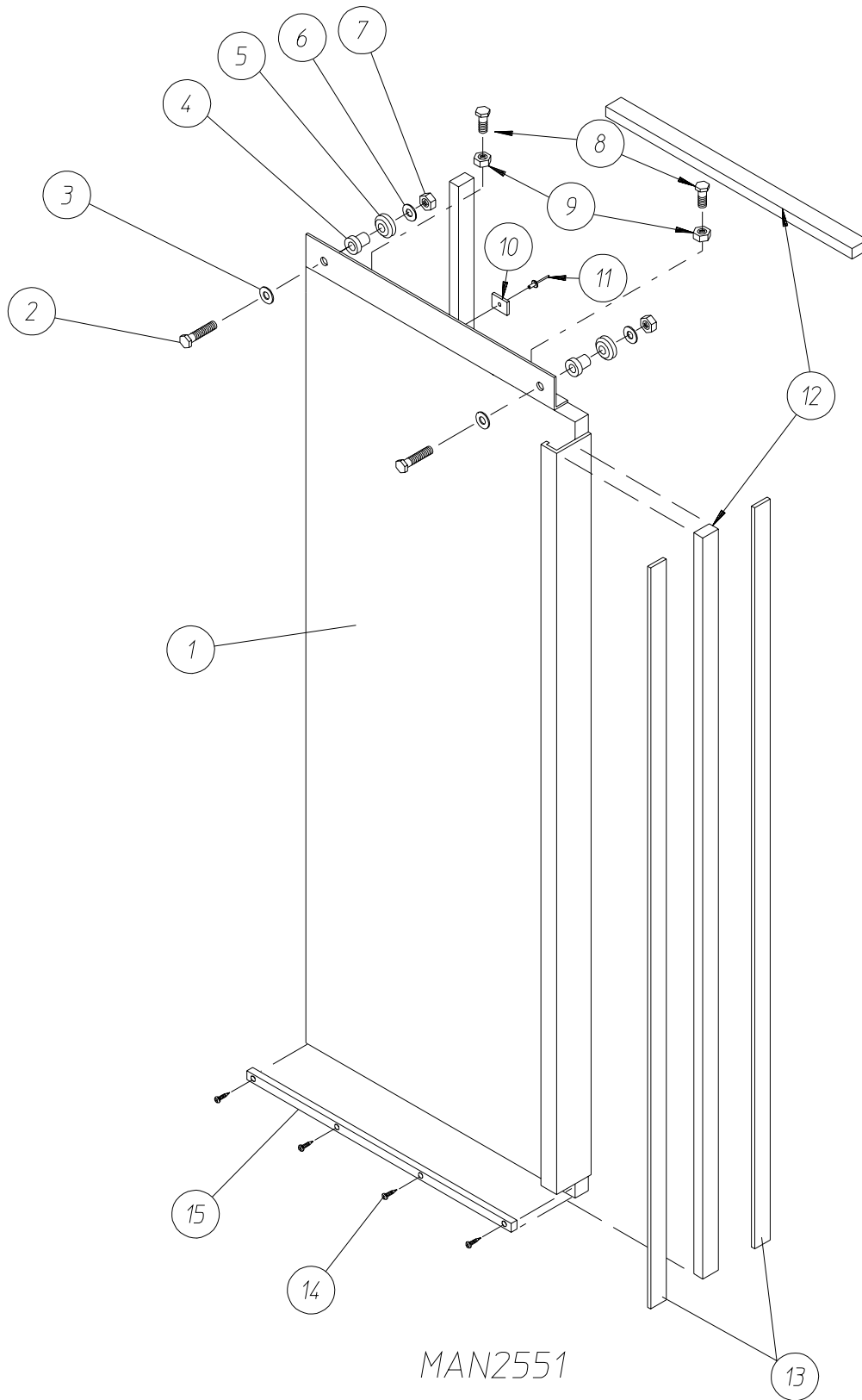



**MANUAL DOOR****for models mfd. as of November 1, 1995**

<u>Illus. No.</u>	<u>Part No.</u>	<u>Qty.</u>	<u>Description</u>
1*	821728	1	Left Manual Load Door Assembly Complete (includes illus. nos. 1 through 15)
2	150112	2	1/4-20 x 1-1/4" Hex Head Machine Screw
3	153018	2	1/4" Flat Washer
4	170367	2	Stainless Steel Stationary Bushing
5	170366	2	Stainless Steel Sealed Wheel
6	153007	2	1/4" Lock Washer
7	152002	2	1/4-20 Hex Nut
8	150512	2	1/4-20 x 1/2" Hex Head Machine Bolt
9	152002	2	1/4-20 Hex Nut
10	102102	1	Door Magnet
11	154200	1	5/32" Pop Rivet
12	115995	125	Felt Gasket (sold by the inch)
13	102111	2	AD-200 Door Magnet
14	150301	4	#8-18 x 7/16" Phillips Pan Head TEK Screw
15	170357	1	Lower Door Slide

\* Specify color when ordering.

**MANUAL DOOR**  
for models mfd. as of November 1, 1995

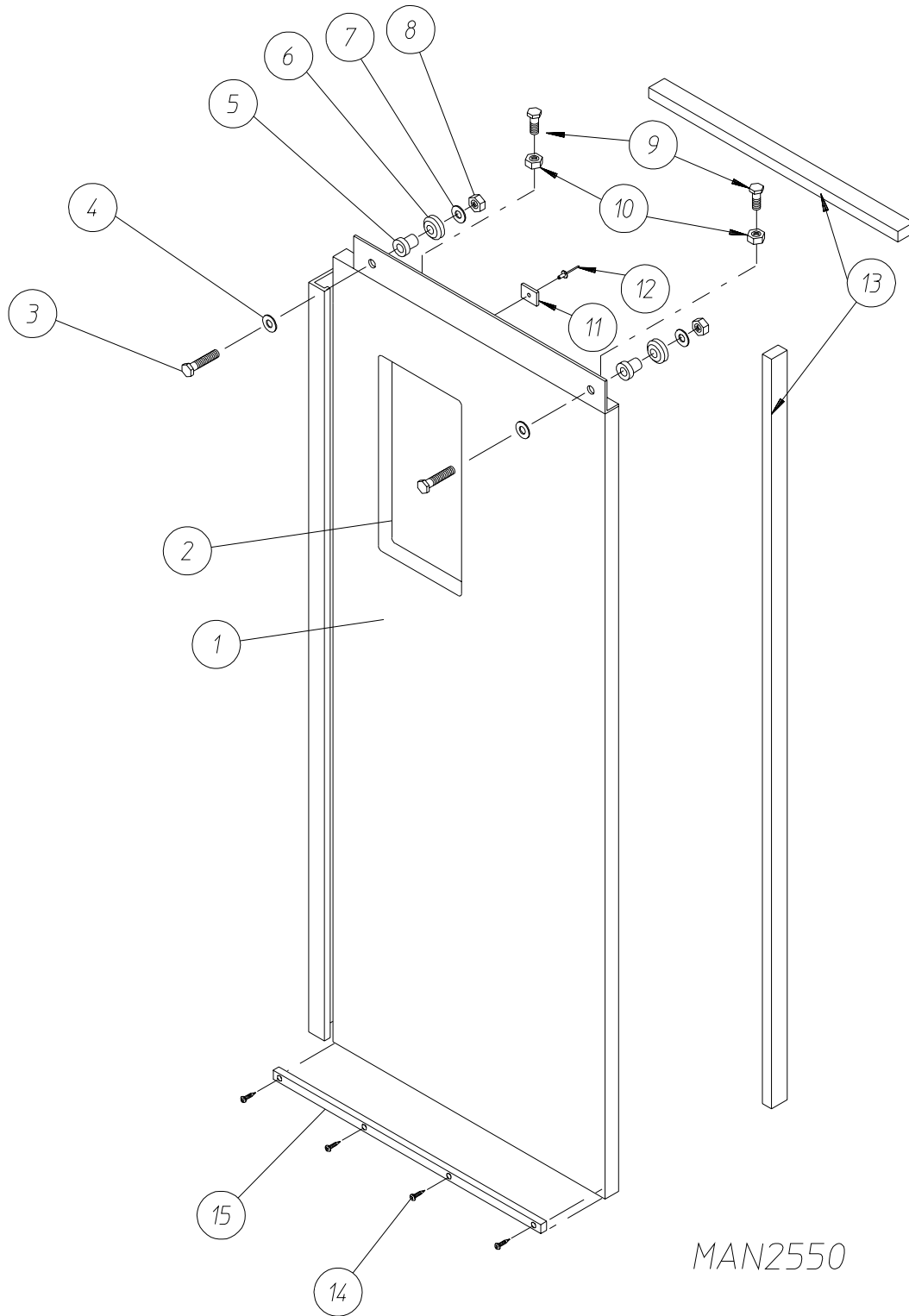

MAN2550

**MANUAL DOOR****for models mfd. as of November 1, 1995**

<u>Illus. No.</u>	<u>Part No.</u>	<u>Qty.</u>	<u>Description</u>
1*	821727	1	Right Manual Load Door Assembly Complete (includes illus. nos. 1 through 15)
2	102215	1	Door Window
	170730	-	Door Window Adhesive (10.3 oz. cartridge)
3	150112	2	1/4-20 x 1-1/4" Hex Head Machine Screw
4	153018	2	1/4" Flat Washer
5	170367	2	Stainless Steel Stationary Bushing
6	170366	2	Stainless Steel Sealed Wheel
7	153007	2	1/4" Lock Washer
8	152002	2	1/4-20 Hex Nut
9	150512	2	1/4-20 x 1/2" Hex Head Machine Bolt
10	152002	2	1/4-20 Hex Nut
11	102102	1	Door Magnet
12	154200	1	5/32" Pop Rivet
13	115995	80	Felt Gasket (sold by the inch)
14	150301	4	#8-18 x 7/16" Phillips Pan Head TEK Screw
15	170357	1	Lower Door Slide

\* Specify color when ordering.

**MANUAL DOOR**  
for models mfd. prior to November 1, 1995

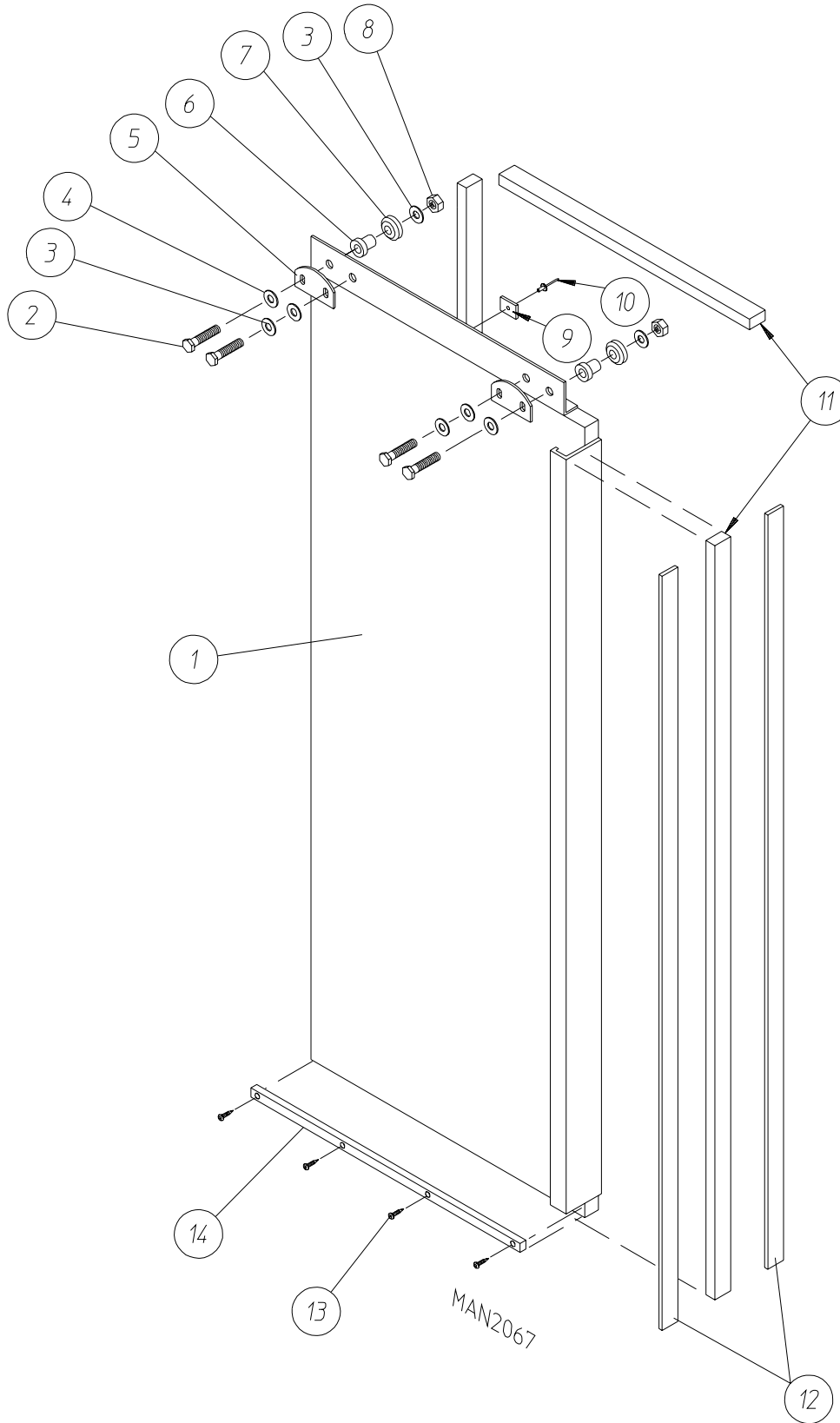

---

**MANUAL DOOR**

**for models mfd. prior to November 1, 1995**

<u>Illus. No.</u>	<u>Part No.</u>	<u>Qty.</u>	<u>Description</u>
1*	881110	1	Left Manual Load Door Assembly Complete (includes illus. nos. 1 through 14)
	881106	1	Left Manual Load Door ONLY
2	150112	4	1/4-20 x 1-1/4" Hex Head Machine Screw
3	153007	4	1/4" Lock Washer
4	153018	4	1/4" Flat Washer
5*	332996	2	Door Trolley Adjustment Plate
6	170367	2	Stainless Steel Stationary Bushing
7	170366	2	Stainless Steel Sealed Wheel
8	152002	2	1/4-20 Hex Nut
9	102102	1	Door Magnet
10	154200	1	5/32" Pop Rivet
11	115995	125	Felt Gasket (sold by the inch)
12	102111	2	AD-200 Door Magnet
13	150301	4	#8-18 x 7/16" Phillips Pan Head TEK Screw
14	170357	1	Lower Door Slide

\* Specify color when ordering.

**MANUAL DOOR**  
for models mfd. prior to November 1, 1995

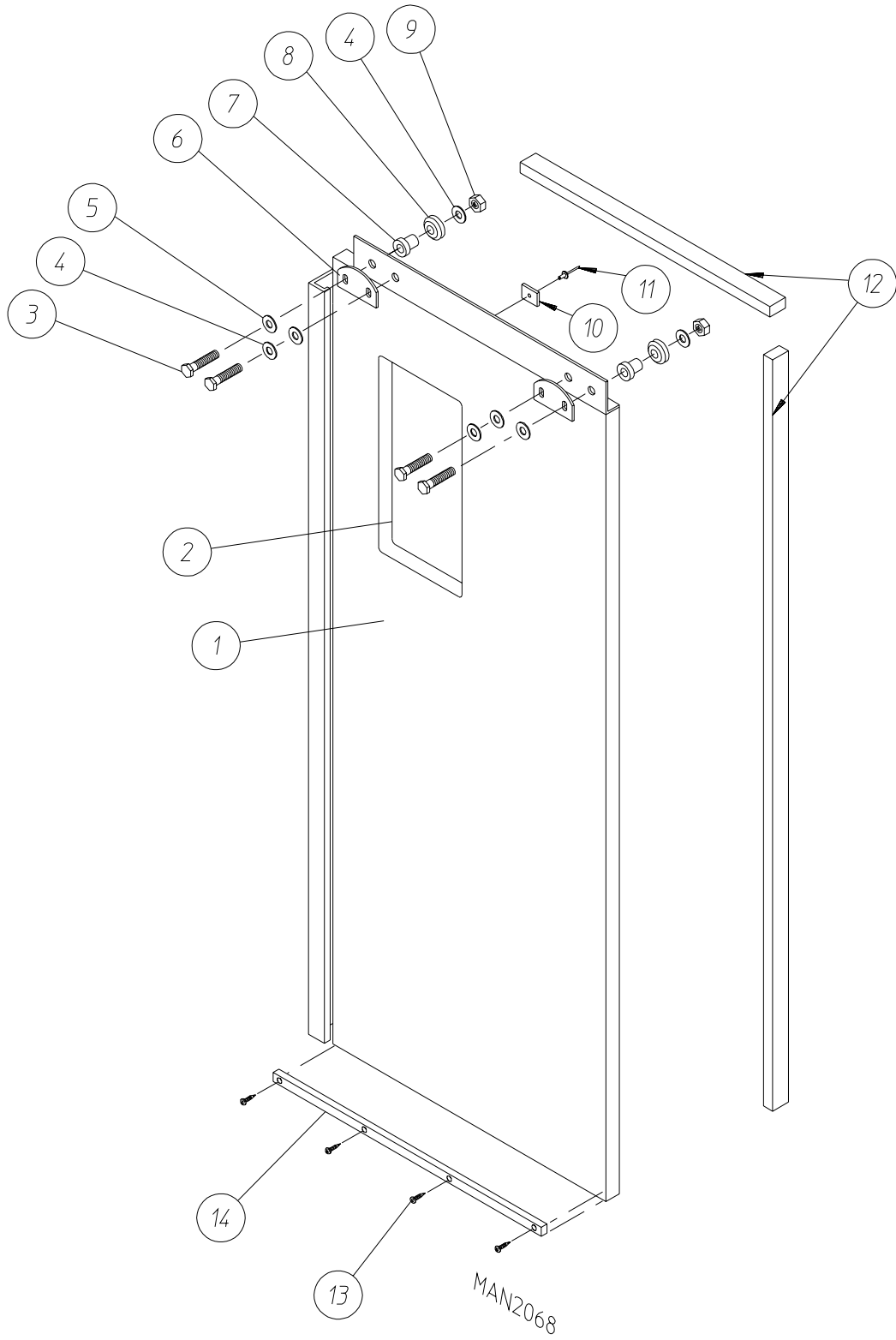

**MANUAL DOOR****for models mfd. prior to November 1, 1995**

<u>Illus. No.</u>	<u>Part No.</u>	<u>Qty.</u>	<u>Description</u>
1*	881111	1	Right Manual Load Door Assembly Complete (includes illus. nos. 1 through 14)
	881107	1	Right Manual Load Door ONLY
2	102215	1	Door Window
	170730	-	Door Window Adhesive (10.3 oz. cartridge)
3	150112	4	1/4-20 x 1-1/4" Hex Head Machine Screw
4	153007	4	1/4" Lock Washer
5	153018	4	1/4" Flat Washer
6*	332996	2	Door Trolley Adjustment Plate
7	170367	2	Stainless Steel Stationary Bushing
8	170366	2	Stainless Steel Sealed Wheel
9	152002	2	1/4-20 Hex Nut
10	102102	1	Door Magnet
11	154200	1	5/32" Pop Rivet
12	115995	80	Felt Gasket (sold by the inch)
13	150301	4	#8-18 x 7/16" Phillips Pan Head TEK Screw
14	170357	1	Lower Door Slide

\* Specify color when ordering.

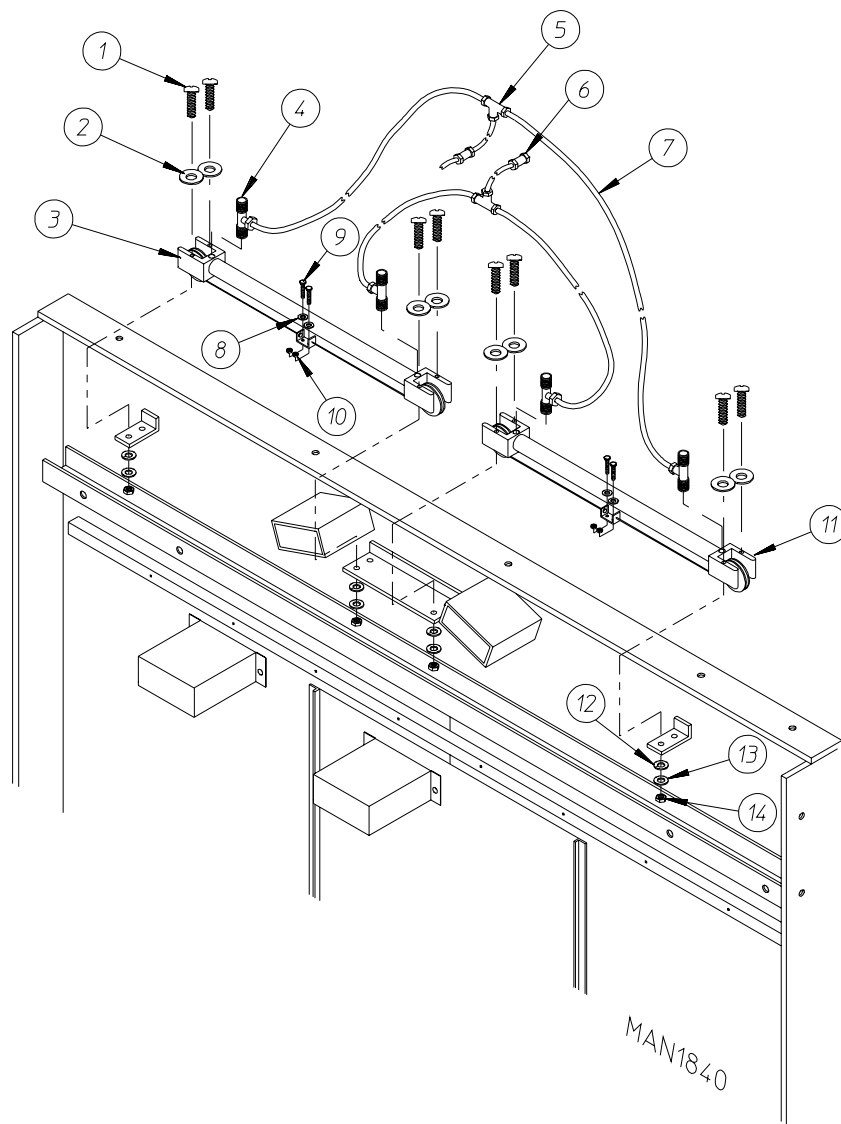
**AUTOMATIC DOOR**

<u>Illus. No.</u>	<u>Part No.</u>	<u>Qty.</u>	<u>Description</u>
1	150308	8	#8-32 x 2-1/2" Phillips Pan Head Machine Screw
2	153000	8	#8 Flat Washer
3	100431	1	Cable Cylinder
4	128978	4	1/8" x 1/4" Tube Flow Control
5	143156	2	1/4" Poly Tee
6	143154	2	1/4" Brass Poly Connector
7	143110	38	1/4" Poly Flo Tubing (sold by the foot)
8	153012	4	#8 Star Washer
9	150103	4	#8-32 x 3/4" Phillips Round Head Machine Screw
10	152001	4	#8-32 Hex Nut
11	100431	1	Cable Cylinder
12	153000	8	#8 Steel Burr
13	153012	8	#8 Star Washer
14	152001	8	#8-32 Hex Nut



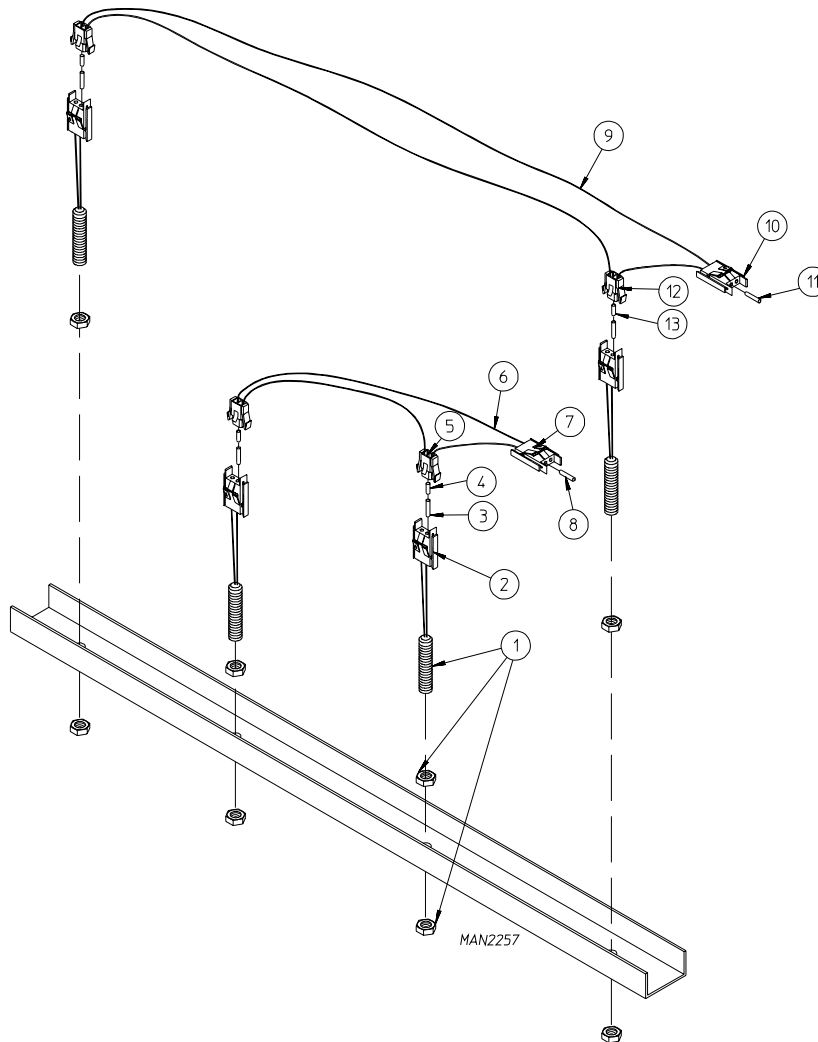

<u>Illus. No.</u>	<u>Part No.</u>	<u>Qty.</u>	<u>Description</u>
1	826514	4	Magnetic Door Switch Assembly with Nuts (includes illus. nos. 1 through 3)
2	122598	1	2-Pin Connector (male)
3	137028	2	Pin
4	137021	4	Microprocessor Socket
5	122599	2	2-Pin Socket Connector (female)
6	881240	1	Door Switch "Closed Position" Harness (includes illus. nos. 4 through 8)
7	122598	1	2-Pin Connector (male)
8	137028	2	Pin
9	881241	1	Door Switch "Open Position" Harness (includes illus. nos. 9 through 13)
10	122598	1	2-Pin Connector (male)
11	137028	2	Pin
12	122599	2	2-Pin Socket Connector (female)
13	137021	4	Microprocessor Socket

**for Gas Models manufactured with Thermal-Magnetic Protection ONLY  
for Gas Models mfd. as of October 2, 1995**

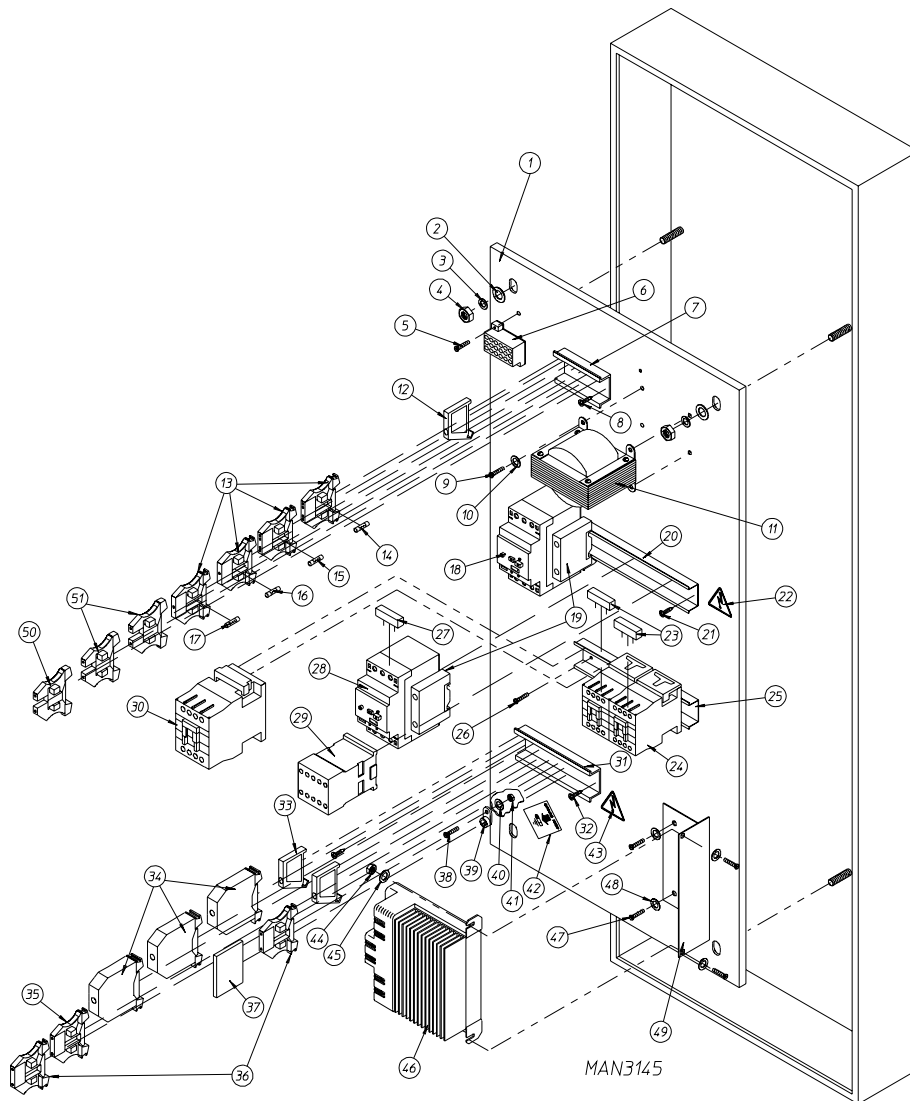

<u>Illus. No.</u>	<u>Part No.</u>	<u>Qty.</u>	<u>Description</u>
1	332594	1	ADG-200 <i>Non-Tilt</i> (Touch Proof) Left Hand Electrical Control Panel ONLY
2	153004	4	3/8" Flat Washer
3	153005	4	3/8" Lock Washer
4	152005	4	3/8-16 Hex Nut
5	150108	2	#8-32 x 1" Phillips Pan Head Machine Screw
6	120730	1	30-Position (A, B, C) Terminal Block
7	120768	4	Din Mounting Rail (sold by the inch)
8	150300	2	#10 x 3/8" Hex Washer TEK Screw
9	150108	4	#8-32 x 1" Phillips Pan Head Machine Screw
10	153000	4	#8 Steel Burr
11	-----	-	Transformer (refer to <b>Transformer Usage Chart</b> on <b>page 66</b> )
12	120765	2	End Stop/Bracket
13	120721	3 or 4*	Fused Disconnect Fuse Holder
14	136057	1	1/2-Amp (Slo Blo) Fuse ONLY (for 208/240 volt models Only)
	136105	1	0.3-Amp Fuse ONLY (for 380 to 600 volt models Only)
15	136057	1	1/2-Amp (Slo Blo) Fuse ONLY (for 208/240 volt models Only)
	136105	1	0.3-Amp (Slo Blo) Fuse ONLY (for 380 to 600 volt models Only)

**for Gas Models manufactured with Thermal-Magnetic Protection ONLY**  
**for Gas Models mfd. as of October 2, 1995**

<u>Illus. No.</u>	<u>Part No.</u>	<u>Qty.</u>	<u>Description</u>
16	136052	1	4-Amp (Slo Blo) Fuse ONLY
17	136057	1	1/2-Amp (Slo Blo) Fuse ONLY (for 380 to 600 volt models Only)
18	131969	1	Blower Motor Manual Starter (for 208/240 volt models Only)
	131963	1	Blower Motor Manual Starter (for 380 volt models Only)
	131970	1	Blower Motor Manual Starter (for 416/460 volt models Only)
	131962	1	Blower Motor Manual Starter (for 575 volt models Only)
19	132384	1	Auxiliary Contact Block (for 208/240/575 volt models Only)
	132389	1	Auxiliary Contact Block (for 380/416/460 volt models Only)
20	120768	6.5	Din Mounting Rail (sold by the inch)
22	122434	1	"Power Warning" Caution Label
23	132437	3	24 - 48 Volt Varistor ONLY
24	132424	1	3 HP 24 VAC Reversing Contactor
25	120768	7	Din Mounting Rail (sold by the inch)
26	150300	2	#10 x 3/8" Hex Washer TEK Screw
27	132437	3	24 - 48 Volt Varistor ONLY
28	131970	1	Drive Motor Manual Starter (for 208/240 volt models Only)
	131968	1	Drive Motor Manual Starter (for 380/416/460 volt models Only)
	131951	1	Drive Motor Manual Starter (for 575 volt models Only)
29**	132444	1	3 HP Control Relay - 110 Volt 50/60 Hz
30	132465	1	7-1/2 HP 24 VAC Blower Contactor
31	120768	3	Din Mounting Rail (sold by the inch)
32	150300	2	#10 x 3/8" Hex Washer TEK Screw
33	120770	2	End Bracket
34	120760	3	Terminal Block
35**	120750	1	Ground Terminal Block
36**	120758	2	Single Position Feed Thru Terminal Block
37**	120766	1	End Section Plate
38	150512	1	1/4-20 x 1/2" Hex Head Machine Bolt
39	121010	1	L-70 Ground Lug
40	153007	1	1/4" Lock Washer
41	152002	1	1/4-20 Hex Nut
42	112075	1	"GROUND HERE" Label
43	122424	1	"POWER WARNING" Caution Label
44	152001	2	#8-32 Hex Nut
45	153000	2	#8 Steel Burr
46	132270	1	3 HP Soft Start (for 208/240 volt models Only)
	132273	1	3 HP Soft Start (for 380/416 volt models Only)
	132271	1	3 HP Soft Start (for 460 volt models Only)
	132272	1	3 HP Soft Start (for 575 volt models Only)
47	150108	1	#8-32 x 1/2" Phillips Pan Head Machine Screw
48	153007	1	1/4" Lock Washer
49	332692	1	Soft Start Mounting Plate
50**	120750	1	Ground Terminal Block
51	120761	2	4-Position Feed Thru Terminal Block

\* For 380 to 600 volt models ONLY.

\*\* For dryers mfd. with the **Sprinkler Option** ONLY.

**for Steam Models manufactured with Thermal-Magnetic Protection ONLY  
for Steam Models mfd. as of October 19, 1995**

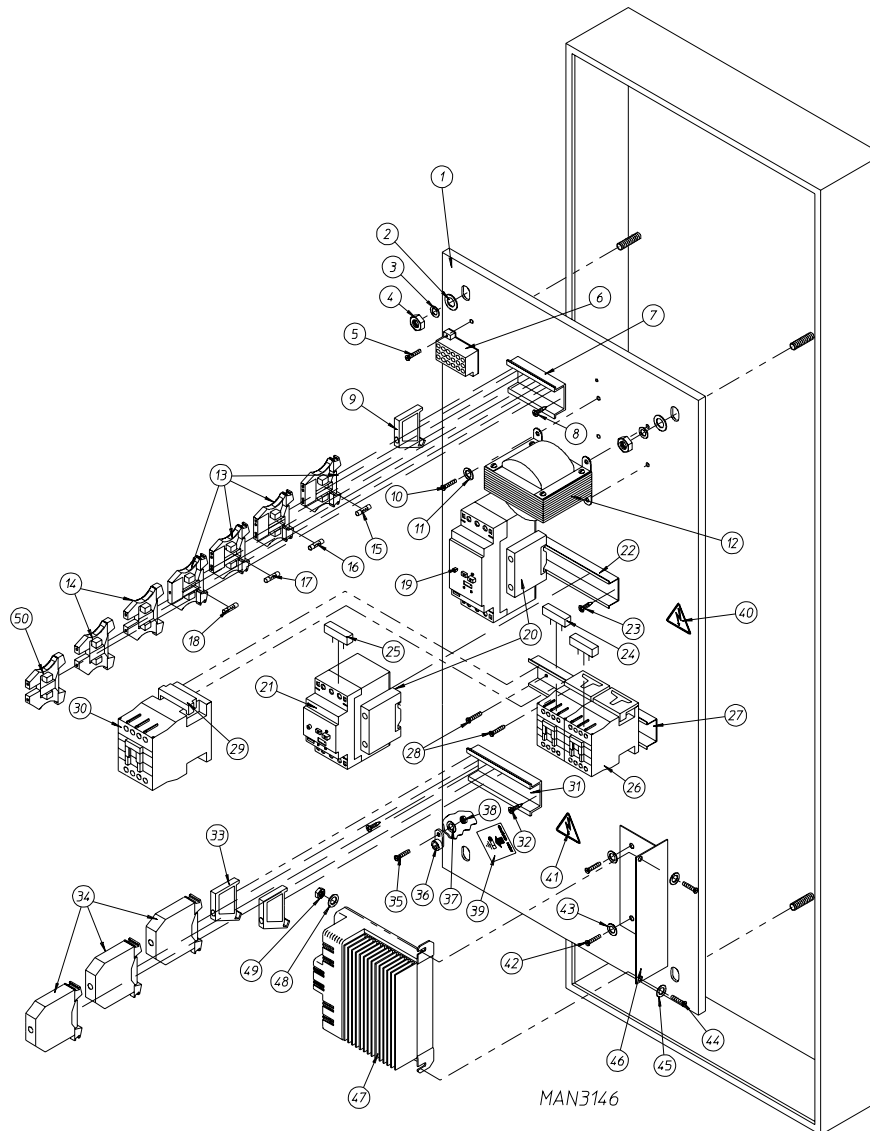

<u>Illus. No.</u>	<u>Part No.</u>	<u>Qty.</u>	<u>Description</u>
1	332594	1	ADS-200 <i>Non-Tilt</i> (Touch Proof) Left Hand Electrical Control Panel ONLY
2	153004	4	3/8" Flat Washer
3	153005	4	3/8" Lock Washer
4	152005	4	3/8-16 Hex Nut
5	150108	2	#8-32 x 1" Phillips Pan Head Machine Screw
6	120730	1	30-Position A, B, C Terminal Block
7	120768	17.5	Din Mounting Rail (sold by the inch)
8	150300	2	#10 x 3/8" Hex Washer TEK Screw
9	120765	2	End Stop/Bracket
10	150108	4	#8-32 x 1" Phillips Pan Head Machine Screw
11	153000	4	#8 Steel Burr
12	-----	-	Transformer (refer to <b>Transformer Usage Chart</b> on <b>page 66</b> )
13	120721	3 or 4*	Fused Disconnect Fuse Holder
14	120761	2	4-Position Feed Thru Terminal Block
15	136057	1	1/2-Amp (Slo Blo) Fuse ONLY (for 208/240 volt models Only)
	136105	1	0.3-Amp Fuse ONLY (for 380 to 600 volt models Only)

---

**for Steam Models manufactured with Thermal-Magnetic Protection ONLY**  
**for Steam Models mfd. as of October 19, 1995**

<u>Illus. No.</u>	<u>Part No.</u>	<u>Qty.</u>	<u>Description</u>
16	136057	1	1/2-Amp (Slo Blo) Fuse ONLY (for 208/240 volt models Only)
	136105	1	0.3-Amp (Slo Blo) Fuse ONLY (for 380 to 600 volt models Only)
17	136038	1	8-Amp Fuse ONLY
18	136057	1	1/2-Amp (Slo Blo) Fuse ONLY (for 380 to 600 volt models Only)
19	131955	1	15 HP Blower Motor Manual Starter (for 208/230 volt models Only)
	131969	1	15 HP Blower Motor Manual Starter (for 380/416/460 volt models Only)
	131954	1	15 HP Blower Motor Manual Starter (for 575 volt models Only)
20	132384	1	Auxiliary Contact Block (for 208/240/575 volt models Only)
	132389	1	Auxiliary Contact Block (for 380/416/460 volt models Only)
21	131970	1	3 HP Drive Motor Manual Starter (for 208/230 volt models Only)
	131968	1	3 HP Drive Motor Manual Starter (for 380/416/460 volt models Only)
	131962	1	3 HP Drive Motor Manual Starter (for 575 volt models Only)
22	120768	17.5	Din Mounting Rail (sold by the inch)
23	150300	2	#10 x 3/8" Hex Washer TEK Screw
24	132437	2	24 - 48 Volt Varistor ONLY
25	132437	1	24 - 48 Volt Varistor ONLY
26	132434	1	3 HP 24 VAC Reversing Contactor
27	120768	17.5	Din Mounting Rail (sold by the inch)
28	150300	2	#10 x 3/8" Hex Washer TEK Screw
29	132485	1	24 - 48 Volt Varistor ONLY (for 208/230 volt models Only)
	132437	1	24 - 48 Volt Varistor ONLY (for 380/416/460/575 volt models Only)
30	132480	1	15 HP Blower Contactor (for 208/240 volt models Only)
	132465	1	15 HP Blower Contactor (for 380/416/460 volt models Only)
	132433	1	15 HP Blower Contactor (for 575 volt models Only)
31	120768	3	Din Mounting Rail (sold by the inch)
32	150300	2	#10 x 3/8" Hex Washer TEK Screw
33	120770	2	End Bracket
34	120760	3	Terminal Block
35	150512	1	1/4-20 x 1/2" Hex Head Machine Bolt
36	121010	1	L-70 Ground Lug
37	153007	1	1/4" Lock Washer
38	152002	1	1/4-20 Hex Nut
39	112075	1	"GROUND HERE " Label
40	122424	1	"POWER WARNING" Caution Label
41	122424	1	"POWER WARNING" Caution Label
42	150108	2	#8-32 x 1/2" Phillips Pan Head Machine Screw
43	153000	2	#8 Steel Burr
44	150108	2	#8-32 x 1/2" Phillips Pan Head Machine Screw
45	153000	2	#8 Steel Burr
46	332692	1	Soft Start Mounting Plate
47	132270	1	3 HP Soft Start (for 208/230 volt models Only)
	132273	1	3 HP Soft Start (for 380/416 volt models Only)
	132271	1	3 HP Soft Start (for 460 volt models Only)
	132272	1	3 HP Soft Start (for 575 volt models Only)
48	153000	2	#8 Steel Burr
49	152001	2	#8-32 Hex Nut
50	112750	1	Ground Terminal Block (for 380 to 600 volt models Only)

\* For 380 - 600 volt models ONLY.

**ADG-200 Left Hand Control Panel Assembly**  
**for Gas Models manufactured with Fuse Protection ONLY**  
**for Gas Models mfd. prior to October 2, 1995**

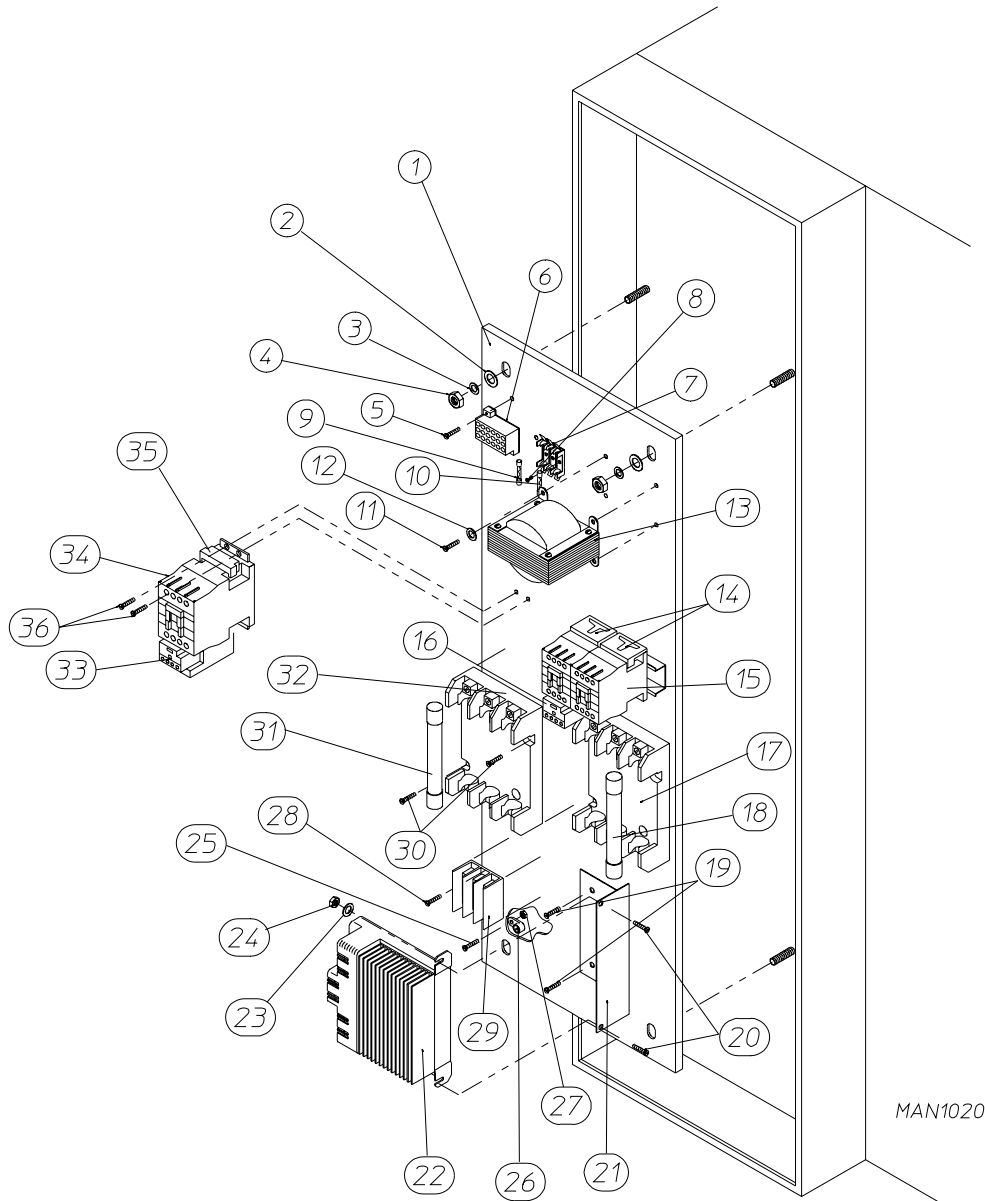

<u>Illus. No.</u>	<u>Part No.</u>	<u>Qty.</u>	<u>Description</u>
1	332594	1	AD-200 Electrical Panel
2	153001	4	5/16" Flat Washer
3	153002	4	5/16" Lock Washer
4	152004	4	5/16-18 Hex Nut
5	150106	2	#8-32 x 1" Phillips Round Head Machine Screw
6	120713	1	18-Position Terminal Block
7	136008	3	Fuse Block/Strip
8	150301	3	#8-18 x 7/16" Phillips Pan Head TEK Screw
9	136057	2	1/2-Amp (Slo Blo) Fuse ONLY
10	136052	1	4-Amp Fuse ONLY
11	150108	4	#8-32 x 1/2" Phillips Pan Head Machine Screw
12	153000	4	#8 Steel Burr

**for Gas Models manufactured with Fuse Protection ONLY**  
**for Gas Models mfd. prior to October 2, 1995**

<u>Illus. No.</u>	<u>Part No.</u>	<u>Qty.</u>	<u>Description</u>
13	-----	-	Transformer (refer to <b>Transformer Usage Chart</b> on <b>page 66</b> )
14	132437	2	Varistor ONLY
15	132434	1	Reversing Drive Motor Contactor (208/230/380/416/480 volt)
	120768	-	Din Mounting Rail ... Not Illustrated (sold by the inch)
	150300	3	#10 x 1/2" Hex Washer TEK Screw ... Not Illustrated
16	132467	1	Drive Motor Overload ( <i>for 208/240 volt models Only</i> )
	132468	1	Drive Motor Overload ( <i>for 380/416/460 volt models Only</i> )
17	136004	1	30-Amp/600 VAC Fuse Block
18	136025	3	12-Amp Fuse ONLY ( <i>for 208/230 volt models Only</i> )
	136022	3	6-Amp Fuse ONLY ( <i>for 380/416 volt models Only</i> )
	136073	3	5-Amp Fuse ONLY ( <i>for 460 volt models Only</i> )
19	150106	4	#8-32 x 1" Phillips Round Head Machine Screw
20	150108	2	#8-32 x 1/2" Phillips Pan Head Machine Screw
21	332692	1	Soft Start Mounting Plate
22	132270	1	Soft Start ( <i>for 208/240 volt models Only</i> ) For models mfd. as of June 1, 1992
	132250	1	Soft Start ( <i>for 208/240 volt models Only</i> ) For models mfd. prior to June 1, 1992
	132272	1	Soft Start ( <i>for 380 volt models Only</i> ) - 60 Hz ONLY
	132273	1	Soft Start ( <i>for 380/416 volt models Only</i> ) - 50 Hz ONLY
	132271	1	Soft Start ( <i>for 460 volt models Only</i> )
23	153000	2	#8 Steel Burr
24	152001	2	#8-32 Hex Nut
25	150111	1	1/4-20 x 1/2" Phillips Round Head Machine Screw
26	121012	1	L-125 Ground Lug
27	152002	1	1/4-20 Hex Nut
28	150108	4	#8-32 x 1/2" Phillips Pan Head Machine Screw
29	120704	1	3-Position Power Distribution Block
30	150108	2	#8-32 x 1/2" Phillips Pan Head Machine Screw
31	-----*	3	Fuse ONLY
32	-----*	1	Fuse Block
33	-----*	1	Blower Motor Overload
34	-----*	1	Blower Contactor
35	-----*	1	Varistor ONLY
36	150300	3	#10 x 1/2" Hex Washer TEK Screw ... Not Illustrated

\* Refer to **AD-200 Overload/Contactor Chart** on **page 65**.

**for Steam Models manufactured with Fuse Protection ONLY  
for Steam Models mfd. prior to October 19, 1995**

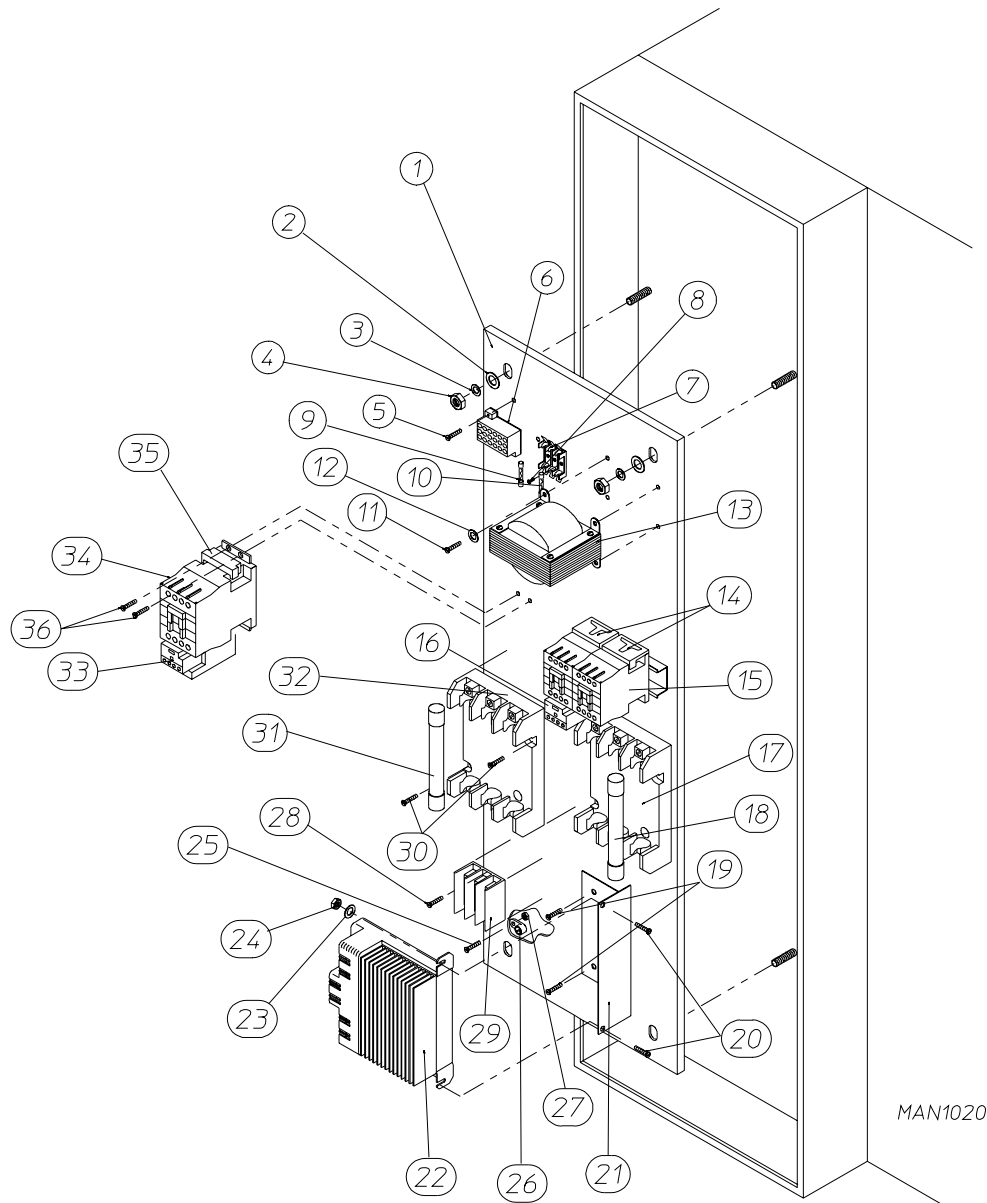

<u>Illus. No.</u>	<u>Part No.</u>	<u>Qty.</u>	<u>Description</u>
1	332594	1	AD-200 Electrical Panel
2	153001	4	5/16" Flat Washer
3	153002	4	5/16" Lock Washer
4	152004	4	5/16-18 Hex Nut
5	150106	2	#8-32 x 1" Phillips Round Head Machine Screw
6	120713	1	18-Position Terminal Block
7	136008	3	Fuse Block/Strip
8	150301	3	#8-18 x 7/16" Phillips Pan Head TEK Screw
9	136057	2	1/2-Amp (Slo Blo) Fuse ONLY
10	136038	1	8-Amp Fuse ONLY
11	150108	4	#8-32 x 1/2" Phillips Pan Head Machine Screw
12	153000	4	#8 Steel Burr



**for Steam Models manufactured with Fuse Protection ONLY  
for Steam Models mfd. prior to October 19, 1995**

<u>Illus. No.</u>	<u>Part No.</u>	<u>Qty.</u>	<u>Description</u>
13	-----	-	Transformer (refer to <b>Transformer Usage Chart</b> on <b>page 66</b> )
14	132437	2	Varistor ONLY
15	132434	1	Reversing Drive Motor Contactor (208/230/380/416/480 volt)
	120768	-	Din Mounting Rail ... Not Illustrated (sold by the inch)
	150300	3	#10 x 1/2" Hex Washer TEK Screw ... Not Illustrated
16	132467	1	Drive Motor Overload ( <i>for 208/240 volt models Only</i> )
	132468	1	Drive Motor Overload ( <i>for 380/416/460 volt models Only</i> )
17	136004	1	30-Amp/600 VAC Fuse Block
18	136025	3	12-Amp Fuse ONLY ( <i>for 208/230 volt models Only</i> )
	136022	3	6-Amp Fuse ONLY ( <i>for 380/416 volt models Only</i> )
	136073	3	5-Amp Fuse ONLY ( <i>for 460 volt models Only</i> )
19	150106	4	#8-32 x 1" Phillips Round Head Machine Screw
20	150108	2	#8-32 x 1/2" Phillips Pan Head Machine Screw
21	332692	1	Soft Start Mounting Plate
22	132270	1	Soft Start ( <i>for 208/240 volt models Only</i> ) For models mfd. as of June 1, 1992
	132250	1	Soft Start ( <i>for 208/240 volt models Only</i> ) For models mfd. prior to June 1, 1992
	132272	1	Soft Start ( <i>for 380 volt models Only</i> ) - 60 Hz ONLY
	132273	1	Soft Start ( <i>for 380/416 volt models Only</i> ) - 50 Hz ONLY
	132271	1	Soft Start ( <i>for 460 volt models Only</i> )
23	153000	2	#8 Steel Burr
24	152001	2	#8-32 Hex Nut
25	150111	1	1/4-20 x 1/2" Phillips Round Head Machine Screw
26	121012	1	L-125 Ground Lug
27	152002	1	1/4-20 Hex Nut
28	150108	4	#8-32 x 1/2" Phillips Pan Head Machine Screw
29	120704	1	3-Position Power Distribution Block
30	150108	2	#8-32 x 1/2" Phillips Pan Head Machine Screw
31	-----*	3	Fuse ONLY
32	-----*	1	Fuse Block
33	-----*	1	Blower Motor Overload
34	-----*	1	Blower Contactor
35	-----*	1	Varistor ONLY
36	150300	3	#10 x 1/2" Hex Washer TEK Screw ... Not Illustrated

\* Refer to **AD-200 Overload/Contactor Chart** on **page 65**.

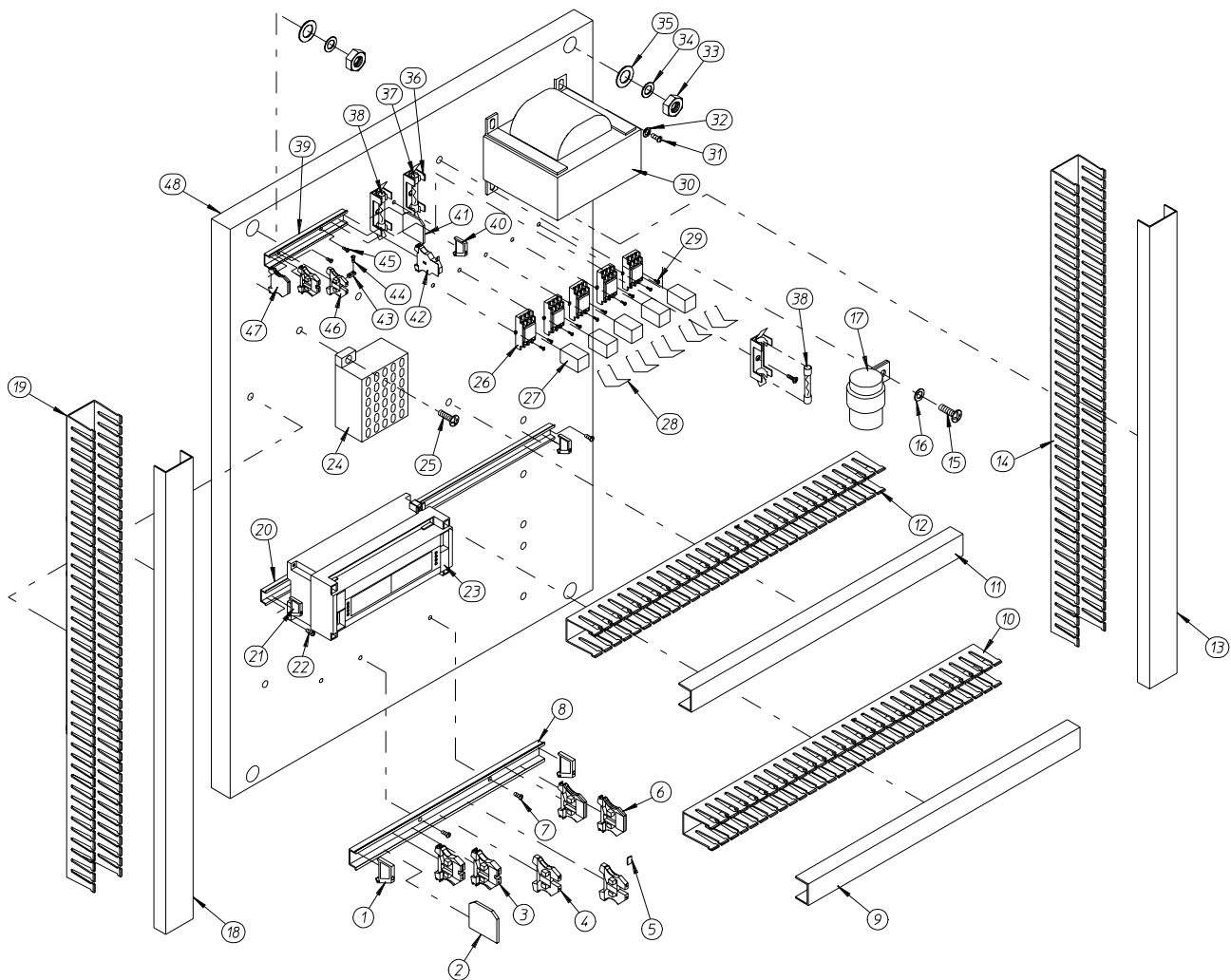

MAN3244

**Illus. No.    Part No.    Qty.    Description**

1	120765	2	End Stop
2	120766	1	End Plate
3	120758	*	Single Input Block
4	120761	*	2-Position Block
5	120999	*	Blank Marking Tag
6	120750	1	Ground Block
7	150415	4	#10-16 x 1/2" Phillips Round Head Crimptite Screw
8	120768	12	Din Rail (sold by the inch)
9	121422	12	Wireway Cover (sold by the inch)
10	121429	12	Wireway (sold by the inch)
11	121422	12	Wireway Cover (sold by the inch)
12	121429	12	Wireway (sold by the inch)

**AUTOMATIC DOOR**

<u>Illus. No.</u>	<u>Part No.</u>	<u>Qty.</u>	<u>Description</u>
13	121422	13	Wireway Cover (sold by the inch)
14	121429	13	Wireway (sold by the inch)
15	150108	1	#8-32 x 1/2" Phillips Pan Head Machine Screw
16	153000	1	#8 Flat Washer
17	826740	1	Solid State Mini Flasher - 24 VAC (for models mfd. as of January 30, 1997)
	881496	1	Solid State Mini Flasher - 24 VAC (replaces Part No. 123220) Used on models mfd. prior to January 30, 1997
18	121422	15	Wireway Cover (sold by the inch)
19	121429	15	Wireway (sold by the inch)
20	120768	12	Din Rail (sold by the inch)
21	120765	2	End Stop
22	150415	2	#10-16 x 1/2" Phillips Round Head Crimptite Screw
23	137912	1	Micro-1 Computer
24	120713	1	18-Position Terminal Block
25	150106	2	#8-32 x 1" Phillips Round Head Machine Screw
26	131408	*	DPDT (Double-Pole-Double-Throw) Socket
27	131407	*	DPDT (Double-Pole-Double-Throw) Relay
28	131409	*	Hold Down
29	150103	*	#8-32 x 3/4" Phillips Pan Head Machine Screw
30	-----	-	Transformer (refer to <b>Transformer Usage Chart</b> on <b>page 66</b> )
31	150108	4	#8-32 x 1/2" Phillips Pan Head Machine Screw
32	153000	4	#8 Flat Washer
33	152005	4	3/8-16 Hex Nut
34	153005	4	3/8" Lock Washer
35	153000	4	3/8" Flat Washer
36	136008	3	Fuse Block
37	136038	1	8-Amp Fuse
38	136057	2	1/2-Amp (Slo Blo) Fuse
39	120768	4	Din Rail (sold by the inch)
40	120765	1	End Stop
41	120766	*	End Plate
42	120752	*	Disconnect Block
43	120990	*	2-Pole Bus Bar (for disconnect block)
44	120998	*	Bus Bar Screw
45	150415	2	#10-16 x 1/2" Phillips Round Head Crimptite Screw
46	120761	*	2-Position Block
47	120750	*	Ground Block
48	332934	1	AD-200 Right Side Electrical Panel

\* As required.

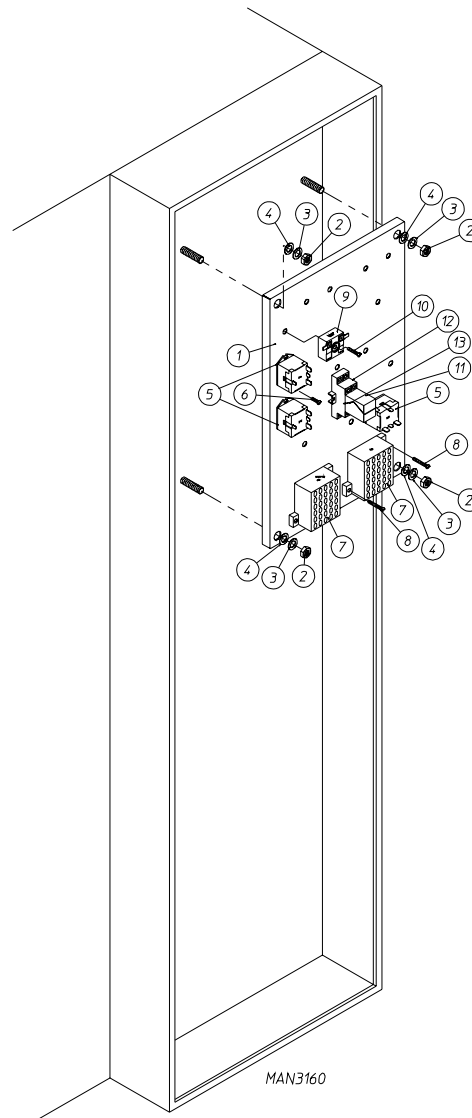

<u>Illus. No.</u>	<u>Part No.</u>	<u>Qty.</u>	<u>Description</u>
1	341370	1	Right Hand Electrical Panel
2	152005	4	3/8-16 Hex Nut
3	153005	4	3/8" Lock Washer
4	153004	4	3/8" Flat Washer
5	131932	3	SPST (Single-Pole-Single-Throw) 24 VAC Panel Mount Relay
6	150108	8	#8-32 x 1/2" Phillips Round Head Machine Screw
7	120715	2	30-Position Terminal Block
8	150106	4	#8-32 x 1" Phillips Round Head Machine Screw
9	826740	1	Solid State Mini Flasher - 24 VAC (for models mfd. as of January 30, 1997)
	881496	1	Solid State Mini Flasher - 24 VAC (replaces Part No. 123220) Used on models mfd. prior to January 30, 1997
10	150103	1	#8-32 x 3/4" Phillips Round Head Machine Screw
11	131407	1	DPDT (Double-Pole-Double-Throw) Relay
12	131408	1	DPDT (Double-Pole-Double-Throw) Relay Socket
13	131409	1	Hold Down Clip

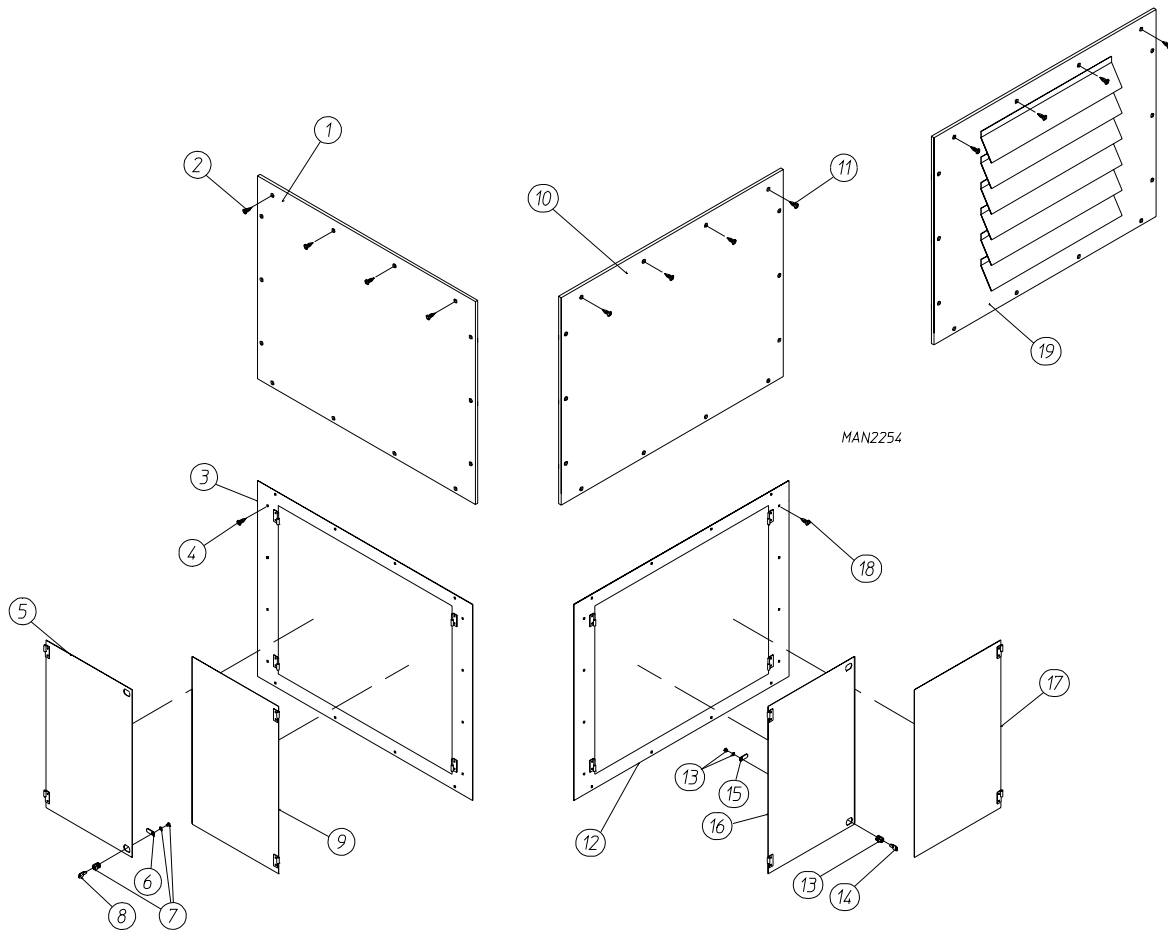

Illus. No.	Part No.	Qty.	Description
1*	821283	1	Left Top Side Panel
2	150523	14	1/4-20 x 3/4" Hex Head TEK Screw
3*	881189	1	Lower Side Panel for Hinged Doors
4	150523	16	1/4-20 x 3/4" Hex Head TEK Screw
5*	881190	1	Locking Hinged Side Panel Door less Locks
6	160034	2	Lock Cam ONLY
7	160050	2	ACE® Door Lock less Key (keyed to #XX4451)
8	160140	2	ACE® XX4451 Key ONLY
9*	881191	1	Hinged Side Panel Door Assembly
10*	821283	1	Top Right Side Panel (for Steam Models ONLY)
11	150523	14	1/4-20 x 3/4" Hex Head TEK Screw
12*	881189	1	Lower Side Panel for Hinged Doors
13	160050	2	ACE® Door Lock less Key (keyed to #XX4451)
14	160140	2	ACE® XX4451 Key ONLY
15	160034	2	Lock Cam ONLY
16*	881190	1	Locking Hinged Side Panel Door less Locks
17*	881191	1	Hinged Side Panel Door Assembly
18	150523	16	1/4-20 x 3/4" Hex Head TEK Screw
19*	821242	1	Top Right Side Panel (for Gas Models ONLY)

\* Specify color when ordering.

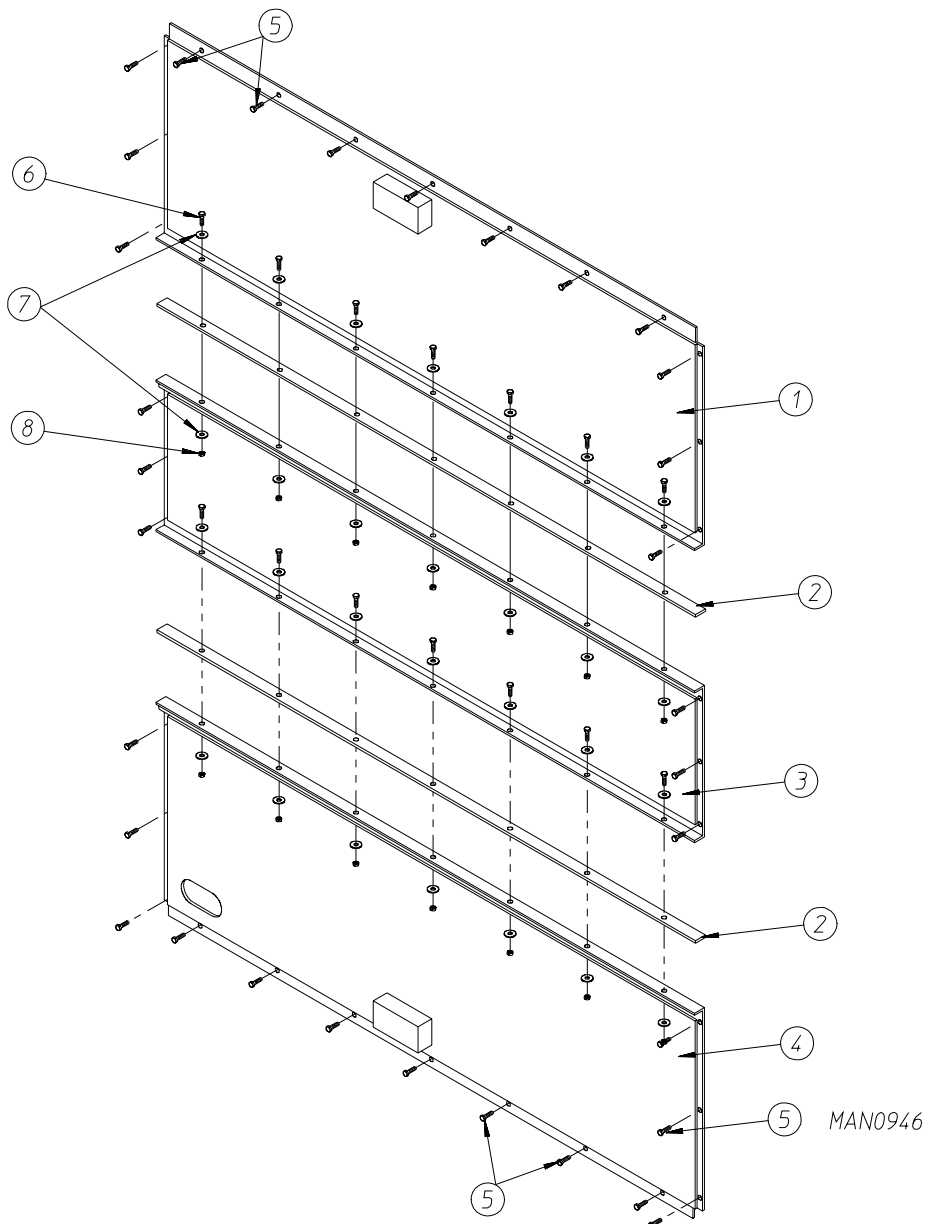

<u>Illus. No.</u>	<u>Part No.</u>	<u>Qty.</u>	<u>Description</u>
1*	821310	1	Top Back Panel Assembly
2	332571	2	Rear Panel Reinforcement
3*	821312	1	Middle Back Panel Assembly
4*	821311	1	Bottom Back Panel Assembly
5	150523	32	1/4-20 x 3/4" Hex Head Machine Bolt
6	150504	14	5/16-18 x 1" Hex Head Machine Bolt
7	153001	28	5/16" Flat Washer
8	152004	14	5/16-18 Hex Nut

\* Specify color when ordering.

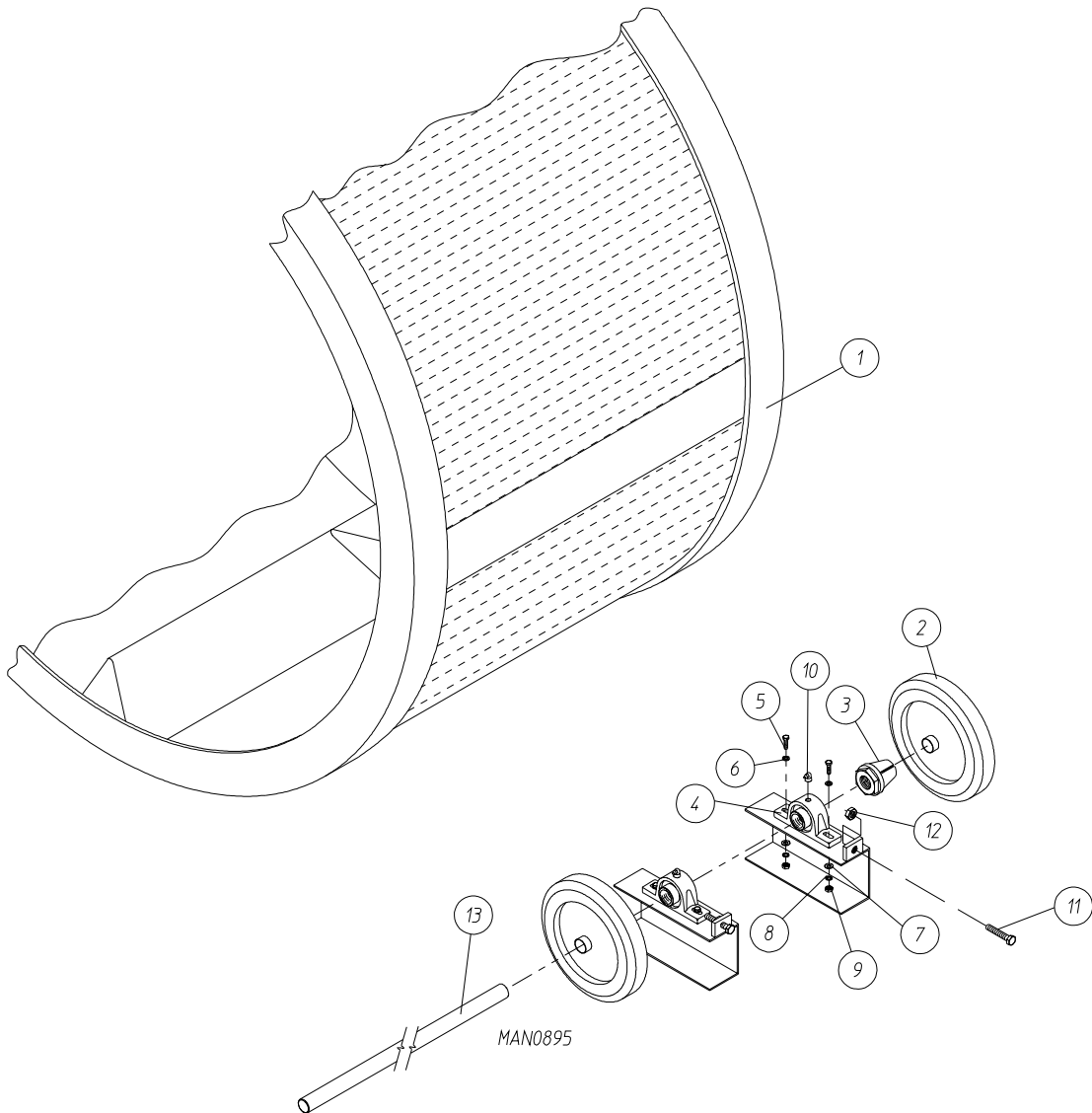

Illus. No.	Part No.	Qty.	Description
1	821217	1	Tumbler Assembly
2	821215	2	Drive Wheel Assembly
3	180007	2	1-1/2" Trantorque
4	880942	2	1-1/2" Pillow Block Bearing with Set Screws and Grease Fitting
5	150620	4	1/2-13 x 2-1/2" Hex Head Machine Bolt
6	153016	4	1/2" Flat Washer
7	153016	4	1/2" Flat Washer
8	153026	4	1/2" Lock Washer
9	152011	4	1/2-13 Hex Nut
10	143217	2	1/4-28 x 90° Lubrication Fitting
11	150609	2	1/2-13 x 4-1/2" Hex Head Machine Bolt
12	152011	2	1/2-13 Hex Nut
13	332507	1	1-1/2" Diameter Idler Shaft

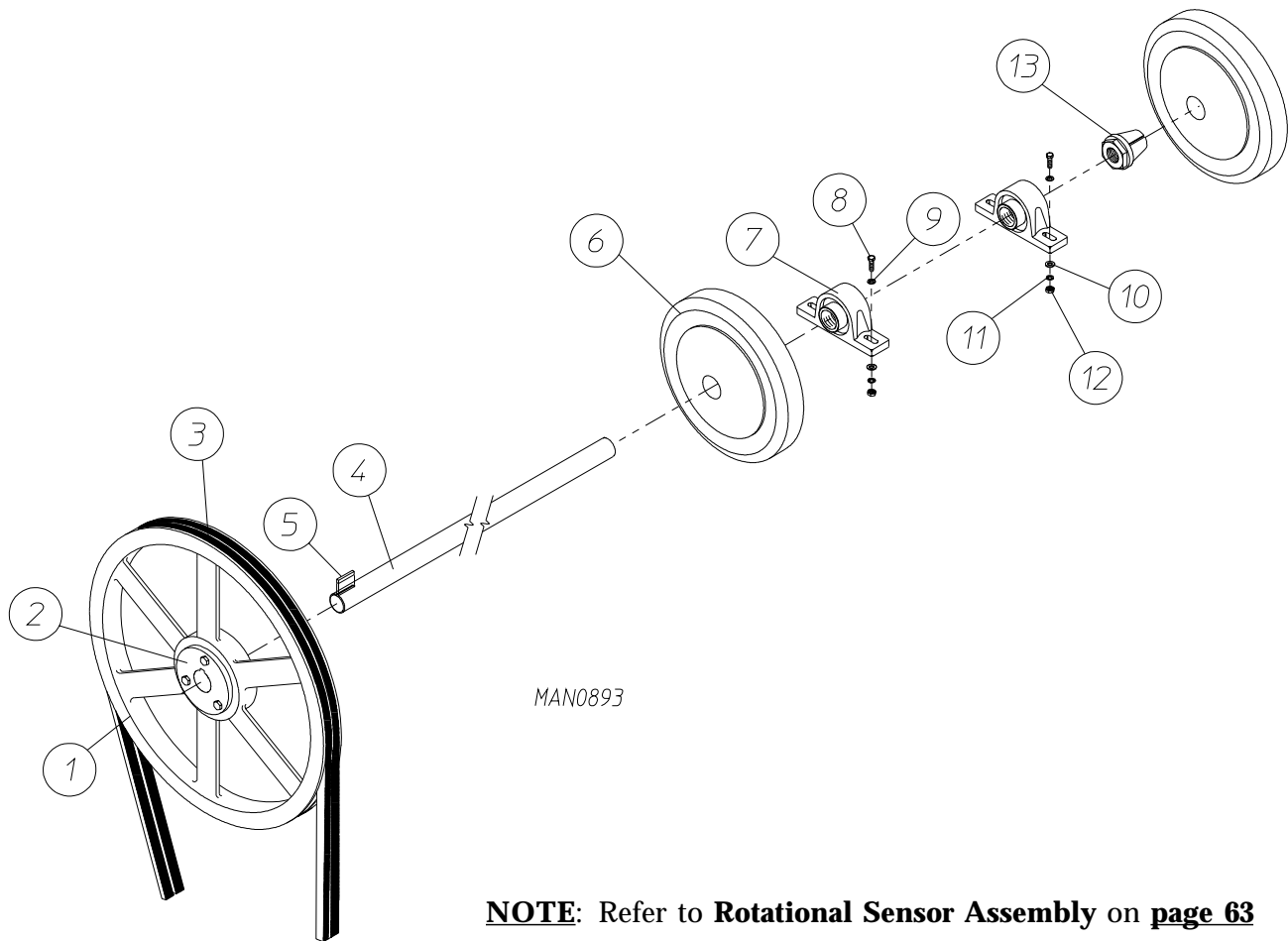

**NOTE:** Refer to **Rotational Sensor Assembly** on **page 63**

Illus. No.	Part No.	Qty.	Description
1	101193	1	2B x 13.6 Pulley
2	101150	1	SK x 1-1/2" Bushing
3*	100129	2	BX-94 Cogged V-Belt (for 60 Hz Models Only)
	100136	2	BX-95 Cogged V-Belt (for 50 Hz Models Only)
4	332508	1	Tumbler Drive Shaft
5	100704	1	1/4" x 1/4" x 1-3/4" Key
6	821215	2	Drive Wheel Assembly
7	880942	2	1-1/2" Pillow Block Bearing with Set Screws and Grease Fitting
8	150620	4	1/2-13 x 2-1/2" Hex Head Machine Bolt
9	153016	4	1/2" Flat Washer
10	153016	4	1/2" Flat Washer
11	153026	4	1/2" Lock Washer
12	152011	4	1/2-13 Hex Nut
13	180007	2	1-1/2" Trantorque

\* Replace in matched sets (both belts).



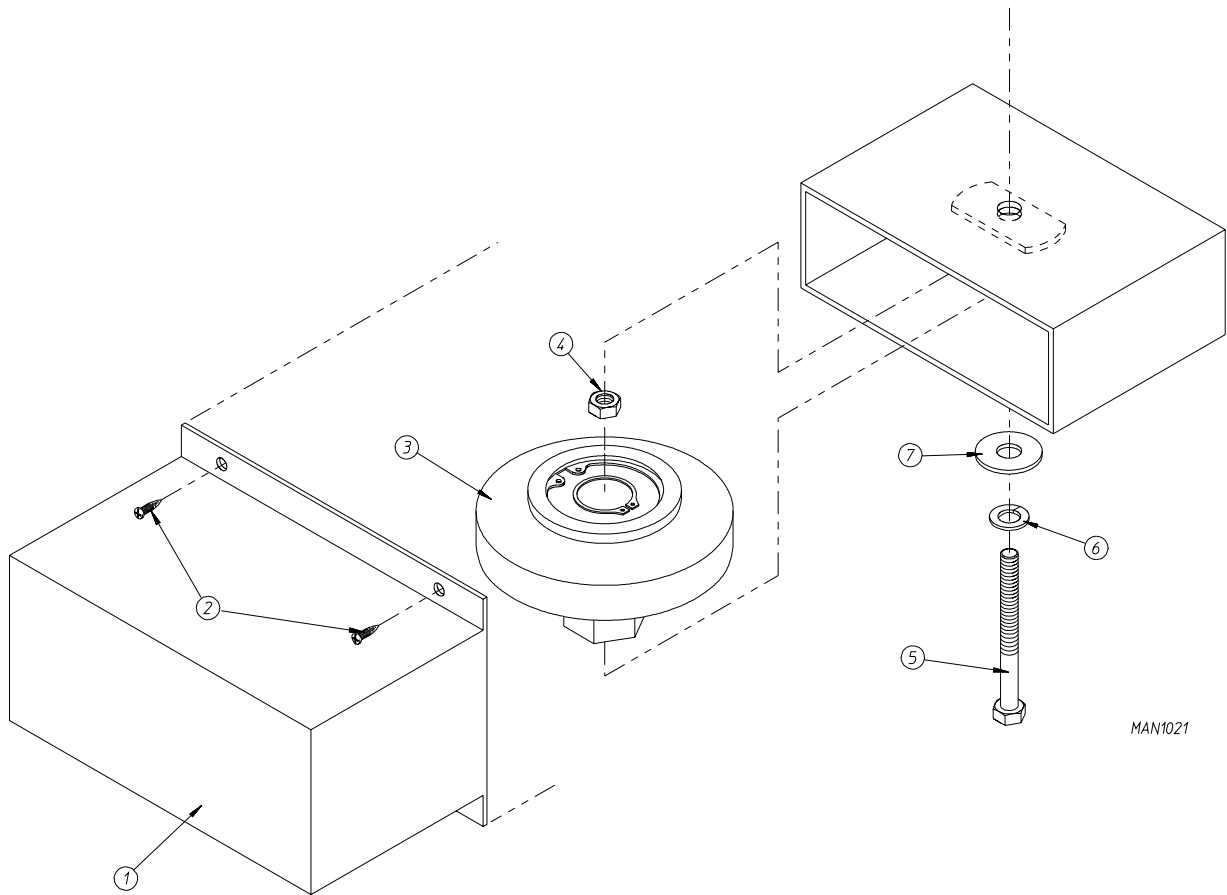

MAN1021

Illus. No.	Part No.	Qty.	Description
1*	821244	1	Tumbler Retaining Wheel Cover
2	150301	4	#8-18 x 7/16" Phillips Pan Head TEK Screw
3	820566	1	Tumbler Retaining Wheel Assembly
4	152004	1	5/16 -18 Hex Nut
5	150509	1	5/16 -18 Hex Head Machine Bolt
6	153002	1	5/16" Lock Washer
7	153001	1	5/16" Flat Washer

\* Specify color when ordering.

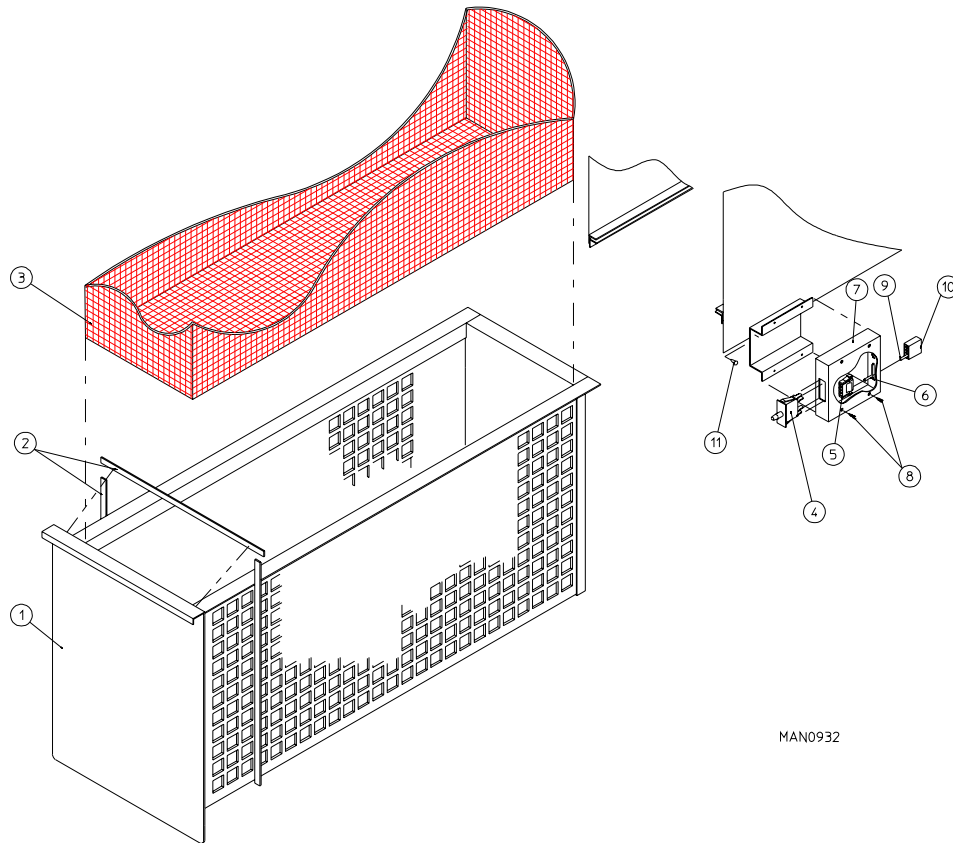

<u>Illus. No.</u>	<u>Part No.</u>	<u>Qty.</u>	<u>Description</u>
1*	880787	1	AD-200 Lint Drawer/Basket Assembly Complete (includes illus. nos. 1 and 2) For models mfd. as of March 2, 1992
	880786	1	AD-200 Lint Drawer/Basket Assembly Complete (includes illus. nos. 1 and 2) For models mfd. prior to March 2, 1992
2	117600	7	Noise Suppressor Tape (sold by the foot)
3	820017	1	AD-200 Lint Screen Assembly (for models mfd. as of March 2, 1992)
	821276	1	AD-200 Lint Screen Assembly (for models mfd. prior to March 2, 1992)
4	122116	1	Lint Drawer/Basket Switch ONLY
5	122605	2	4-Pin Socket Connector ONLY
6	122701	4	Socket Terminal ONLY
	122801	1	Pin/Socket Extraction Tool
7	800264	1	Lint Drawer/Basket Switch Box Assembly Complete (includes illus. nos. 4 through 7)
	304034	1	Lint Drawer/Basket Switch Cover ONLY
8	150301	4	#8-18 x 7/16" Phillips Pan Head TEK Screw
9	122700	4	Pin Terminal ONLY
10	122604	2	4-Pin Connector ONLY
11	150301	2	#8-18 x 7/16" Phillips Pan Head TEK Screw

\* Specify color when ordering.

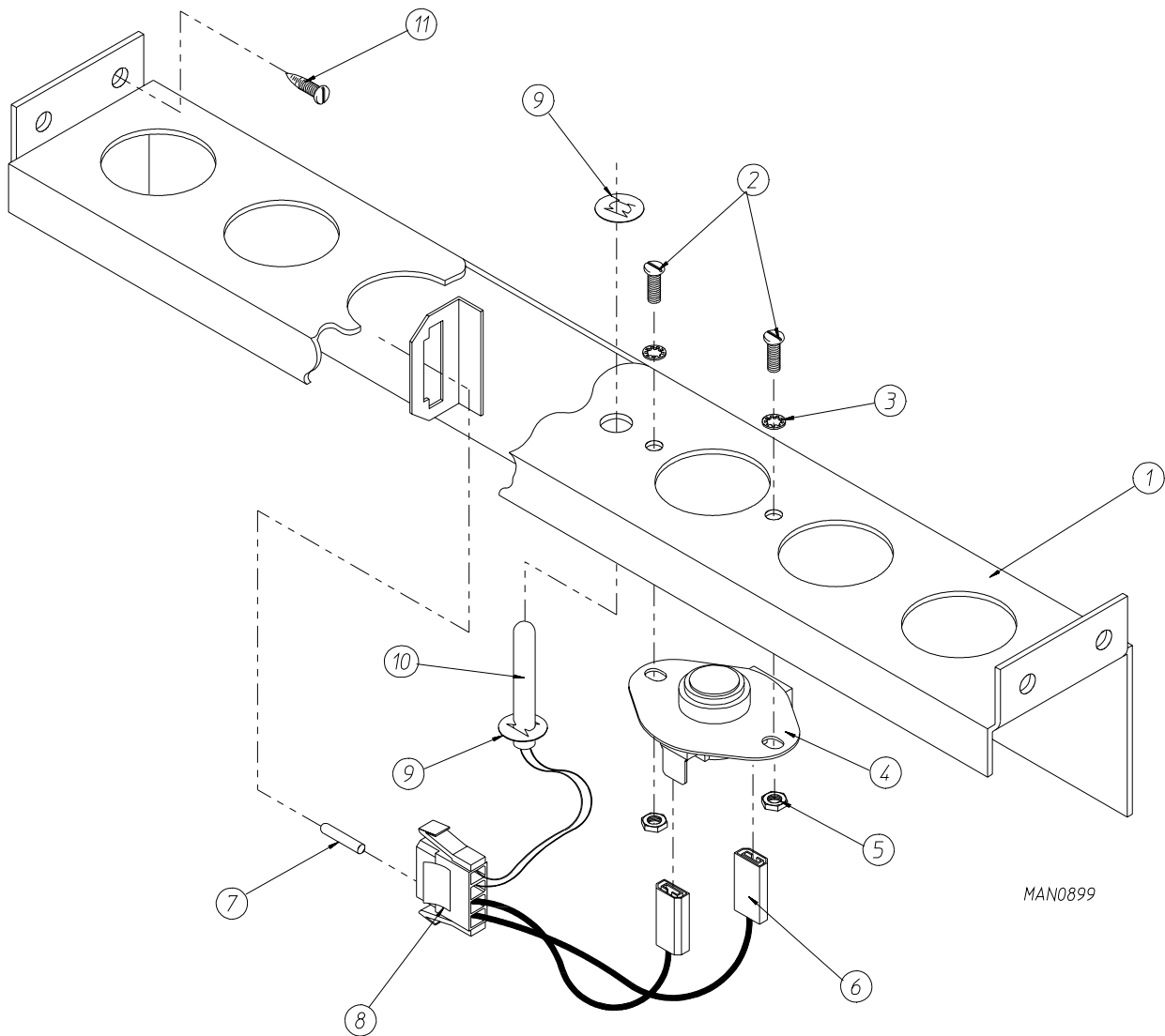

MAN0899

Illus. No.	Part No.	Qty.	Description
1	820967	1	Sensor Bracket Assembly ONLY
	820968	1	Sensor Bracket Assembly Complete (includes illus. nos. 1 through 10)
2	150000	2	#6-32 x 1/4" Slotted Round Head Machine Screw
3	153010	2	#6 Star Washer
4	130112	1	225° Thermostat ONLY
5	152000	2	#6-32 Hex Nut
6	121028	2	1/4" x .032 Insulated Terminal
7	122701	4	Socket Terminal ONLY
8	122605	1	4-Pin Socket Connector (female)
9	154007	2	1/4" Push-On Fastener
10	880251	1	1/4" Temperature Sensor Probe
11	150301	4	#8-18 x 7/16" Phillips Pan Head TEK Screw

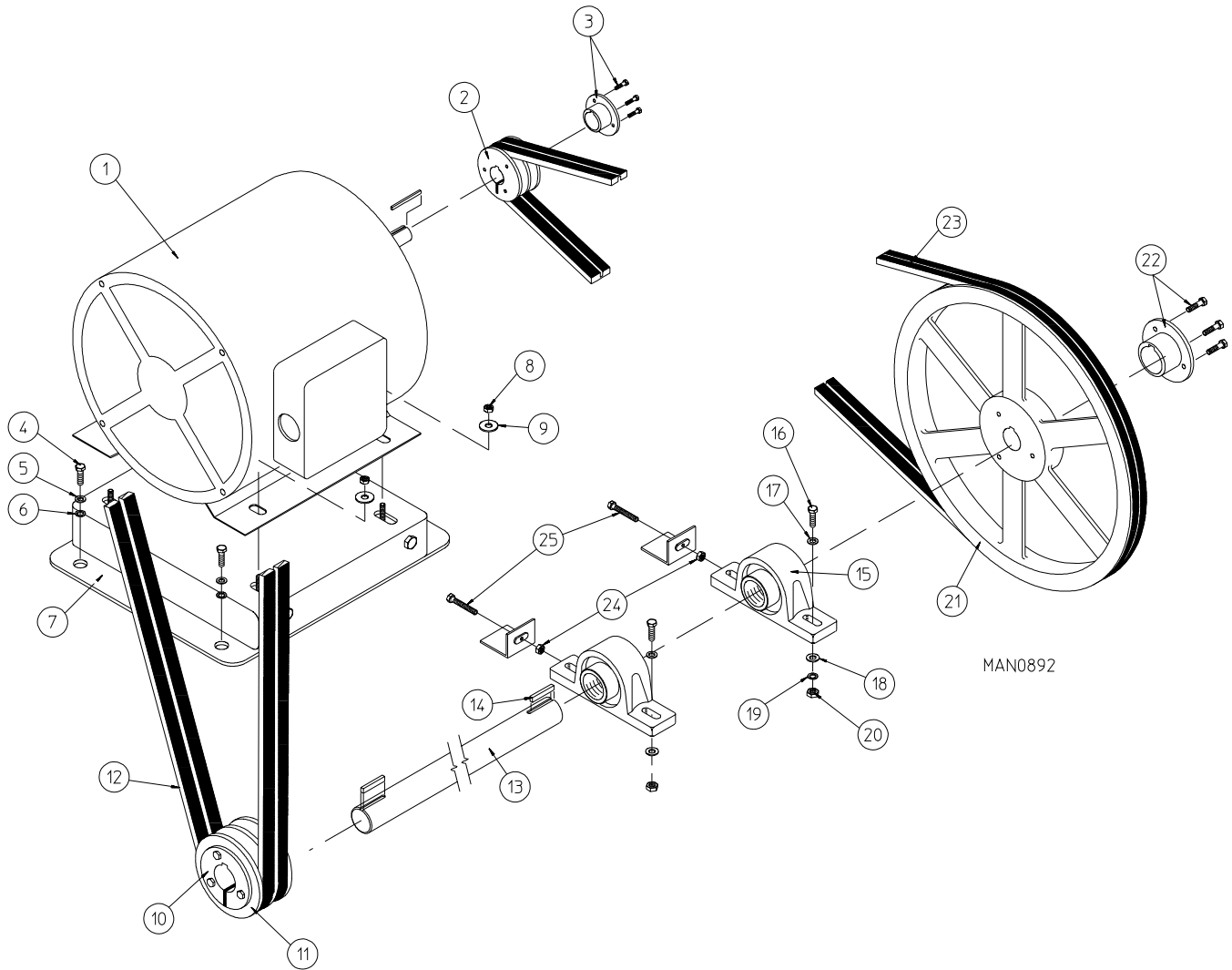

<u>Illus. No.</u>	<u>Part No.</u>	<u>Qty.</u>	<u>Description</u>
1	100043	1	3 HP Motor 208-230/460v 3 $\phi$ 60 Hz Models and 190/380/416v 3 $\phi$ 50 Hz Models
	100081	1	3 HP Motor 380v 3 $\phi$ 60 Hz Models and 200-230/400v 3 $\phi$ 50 Hz Models
	100019	1	3 HP Motor 575v 3 $\phi$ 60 Hz Models
2	101143	1	2B x 3.8" Pulley
3	101144	1	SH x 1-1/8" Bushing
4	150617	4	3/8-16 x 1" Hex Head Machine Bolt
5	153005	4	3/8" Lock Washer
6	153004	4	3/8" Flat Washer
7	100060	1	Motor Base
8	152005	4	3/8-16 Hex Nut
9	153004	4	3/8" Flat Washer
10	101149	1	SH x 1-1/4" Bushing (for 60 Hz models Only)
	101166	1	SDS x 1-1/4" Bushing (for 50 Hz models Only)
11	101148	1	2B x 4.0 Pulley (for 60 Hz models Only)
	101147	1	2B x 4.8 Pulley (for 50 Hz models Only)
12*	100129	2	BX-94 Cogged V-Belt
	100136	2	BX-95 Cogged V-Belt
13	341033	1	1-1/4" Idler Shaft (Drive Motor)
14	100704	2	1/4" x 1/4" x 1-3/4" Key
15	880941	2	1-1/4" Idler Bearing with Set Screws and Grease Fitting
16	150600	4	3/8-16 x 1-1/2" Hex Head Machine Bolt
17	153004	4	3/8" Flat Washer
18	153004	4	3/8" Flat Washer
19	153005	4	3/8" Lock Washer
20	152005	4	3/8-16 Hex Nut
21	101145	1	2B x 11.0 Pulley
22	101146	1	SK x 1-1/4 Bushing
23*	100128	2	BX-50 Cogged V-Belt
24	152004	2	5/16-18 Hex Nut (for models mfd. as of October 2, 1992)
	152005	2	3/8-16 Hex Nut (for models mfd. prior to October 2, 1992)
25	150613	2	5/16-18 x 4" Hex Head Machine Bolt (for models mfd. as of October 2, 1992)
	880799	2	3/8-16 x 4" Hex Head Machine Bolt (for models mfd. prior to October 2, 1992)

\* Replace belts in matched sets (both belts).

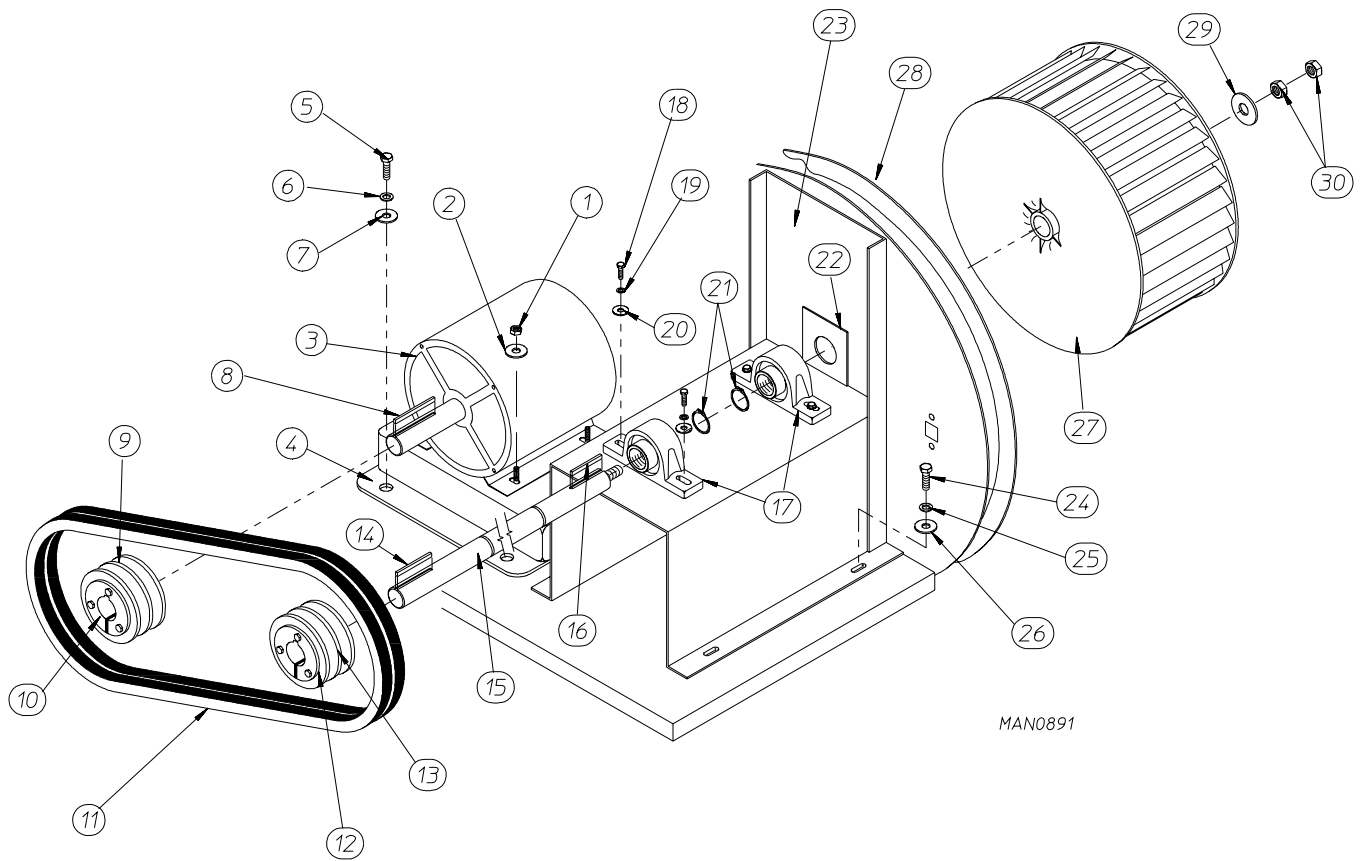

**for Gas Models ONLY**

<u>Illus. No.</u>	<u>Part No.</u>	<u>Qty.</u>	<u>Description</u>
1	152005	4	3/8-16 Hex Nut
2	153004	4	3/8" Flat Washer
3	100046	1	7.5 HP Blower Motor 208-230/460v 3Ø 60 Hz Models
	100092	1	7.5 HP Blower Motor 380v 3Ø 60 Hz Models and 190-208/380-416v 3Ø 50 Hz Models
	100021	1	7.5 HP Blower Motor 575v 3Ø 60 Hz Models
4	100062	1	Blower Motor Slide Base
5	150617	4	3/8-16 x 1" Hex Head Machine Bolt
6	153005	4	3/8" Lock Washer
7	153004	4	3/8" Flat Washer
8	100706	1	5/16" x 5/16" x 1-3/8" Key
9	101148	1	2B x 4.0 Pulley (for 60 Hz models Only)
	101147	1	2B x 4.8 Pulley (for 50 Hz models Only)
10	101152	1	SH x 1-3/8" Bushing (for 60 Hz models Only)
	101194	1	SDS x 1-3/8" Bushing (for 50 Hz models Only)
11*	100140	2	BX-38 Cogged V-Belt
12	101152	1	SH x 1-3/8" Bushing
13	101148	1	2B x 4.0 Pulley (for models mfd. as of March 2, 1992)
	101195	1	2B x 4.4 Pulley (for models mfd. prior to March 2, 1992)
14	100706	1	5/16" x 5/16" x 1-3/8" Key
15	332703	1	AD-200 Squirrel Cage (Blower Wheel) Shaft (for models mfd. as of March 2, 1992)
	332626	1	AD-200 Squirrel Cage (Blower Wheel) Shaft (for models mfd. prior to March 2, 1992)
16	100706	1	5/16" x 5/16" x 1-3/8" Key
17	880879	2	1-3/8" Idler Bearing with Set Screws and Grease Fitting
18	150617	4	3/8-16 x 1" Hex Head Machine Bolt
19	153005	4	3/8" Lock Washer
20	153004	4	3/8" Flat Washer
21	100802	2	1-3/8" Retaining Ring
22	116014	1	Felt Seal (3" x 3")
23**	880788	1	Motor Mount Assembly (includes illus. nos. 23 and 28) For models mfd. as of March 2, 1992
	821229	1	Motor Mount Assembly (includes illus. nos. 23 and 28) For models mfd. prior to March 2, 1992
24	150617	4	3/8-16 x 1" Hex Head Machine Bolt
25	153005	4	3/8" Lock Washer
26	153004	4	3/8" Flat Washer
27	100612	1	1-1/4" Bore x 15" Squirrel Cage (Blower Wheel)
28	117600	4	Noise Suppressor Tape (sold by the foot)
29	153050	1	1/2" Flat Washer
30	152006	2	1/2-20 Left Hand Jam Nut

\* Replace belts in matched sets (both belts).

\*\* Specify color when ordering.

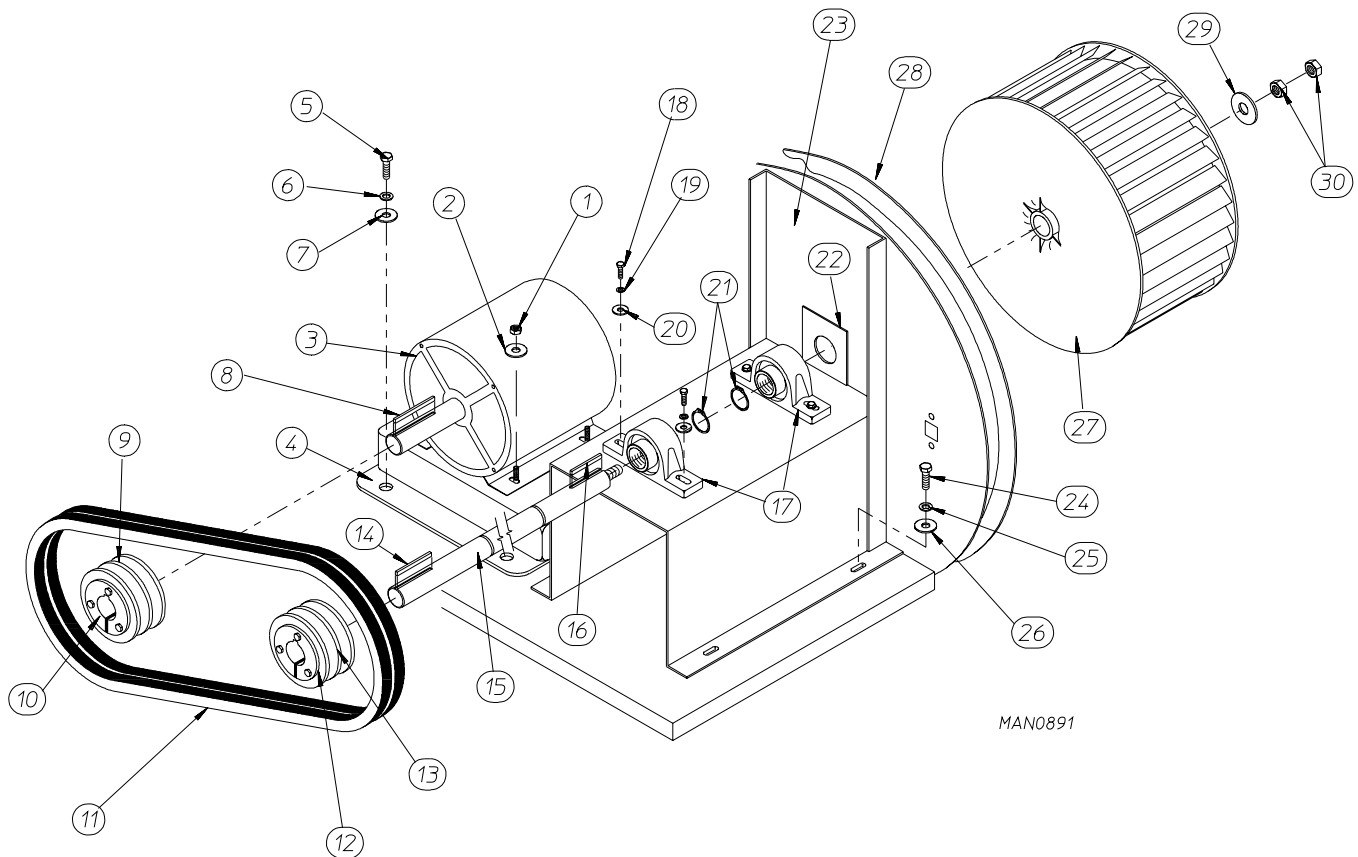
for Steam Models **ONLY**

<u>Illus. No.</u>	<u>Part No.</u>	<u>Qty.</u>	<u>Description</u>
1	152005	4	3/8-16 Hex Nut
2	153004	4	3/8" Flat Washer
3	100087	1	15 HP Blower Motor 208-230/460v 3 $\phi$ 60 Hz Models and 190-230/380-416v 3 $\phi$ 50 Hz Models (for models mfd. as of July 20, 1992)
	100082	1	15 HP Blower Motor 380v 3 $\phi$ 60 Hz Models
	181001	1	15 HP Blower Motor 575v 3 $\phi$ 60 Hz Models
	100046	1	7.5 HP Blower Motor (for 60 Hz Models Only) For models mfd. prior to July 20, 1992
	100092	1	7.5 HP Blower Motor (for 50 Hz Models Only) For models mfd. prior to July 20, 1992
4	100062	1	Blower Motor Slide Base
5	150617	4	3/8-16 x 1" Hex Head Machine Bolt



**for Steam Models ONLY**

<u>Illus. No.</u>	<u>Part No.</u>	<u>Qty.</u>	<u>Description</u>
6	153005	4	3/8" Lock Washer
7	153004	4	3/8" Flat Washer
8	100706	1	5/16" x 5/16" x 1-3/8" Key
9	101148	1	2B x 4.0 Pulley (for 60 Hz models Only)
	101195	1	2B x 4.4 Pulley (for 50 Hz models Only)
10	101152	1	SH x 1-3/8" Bushing - 50/60 Hz
11*	100142	2	BX-42 Cogged V-Belt (for models mfd. as of July 20, 1992)
	100140	2	BX-38 Cogged V-Belt (for models mfd. prior to July 20, 1992)
12	101194	1	SDS x 1-3/8" Bushing - for models mfd. as of March 15, 1992
	101152	1	SH x 1-3/8" Bushing - for models mfd. prior to March 15, 1992
13	101175	1	2B x 6.8 Pulley (for models mfd. as of July 20, 1992)
	101134	1	2B x 4.6 Pulley (for models mfd. between March 15, 1992 and July 20, 1992)
	101148	1	2B x 4.4 Pulley (for models mfd. prior to July 20, 1992)
14	100706	1	5/16" x 5/16" x 1-3/8" Key
15	332703	1	AD-200 Squirrel Cage (Blower Wheel) Shaft (for models mfd. as of March 2, 1992)
	332626	1	AD-200 Squirrel Cage (Blower Wheel) Shaft (for models mfd. prior to March 2, 1992)
16	100706	1	5/16" x 5/16" x 1-3/8" Key
17	880879	2	1-3/8" Idler Bearing with Set Screws and Grease Fitting
18	150617	4	3/8-16 x 1" Hex Head Machine Bolt
19	153005	4	3/8" Lock Washer
20	153004	4	3/8" Flat Washer
21	100802	2	1-3/8" Retaining Ring
22	116014	1	Felt Seal (3" x 3")
23**	880788	1	Motor Mount Assembly - for models mfd. as of March 2, 1992 (includes illus. nos. 23 and 28)
	821229	1	Motor Mount Assembly - for models mfd. prior to March 2, 1992 (includes illus. nos. 23 and 28)
24	150617	4	3/8-16 x 1" Hex Head Machine Bolt
25	153005	4	3/8" Lock Washer
26	153004	4	3/8" Flat Washer
27	100612	1	1-1/4" Bore x 15" Squirrel Cage (Blower Wheel)
28	117600	4	Noise Suppressor Tape (sold in feet)
29	153050	1	1/2" Flat Washer
30	152006	2	1/2-20 Left Hand Jam Nut

\* Replace belts in matched sets (both belts).

\*\* Specify color when ordering.

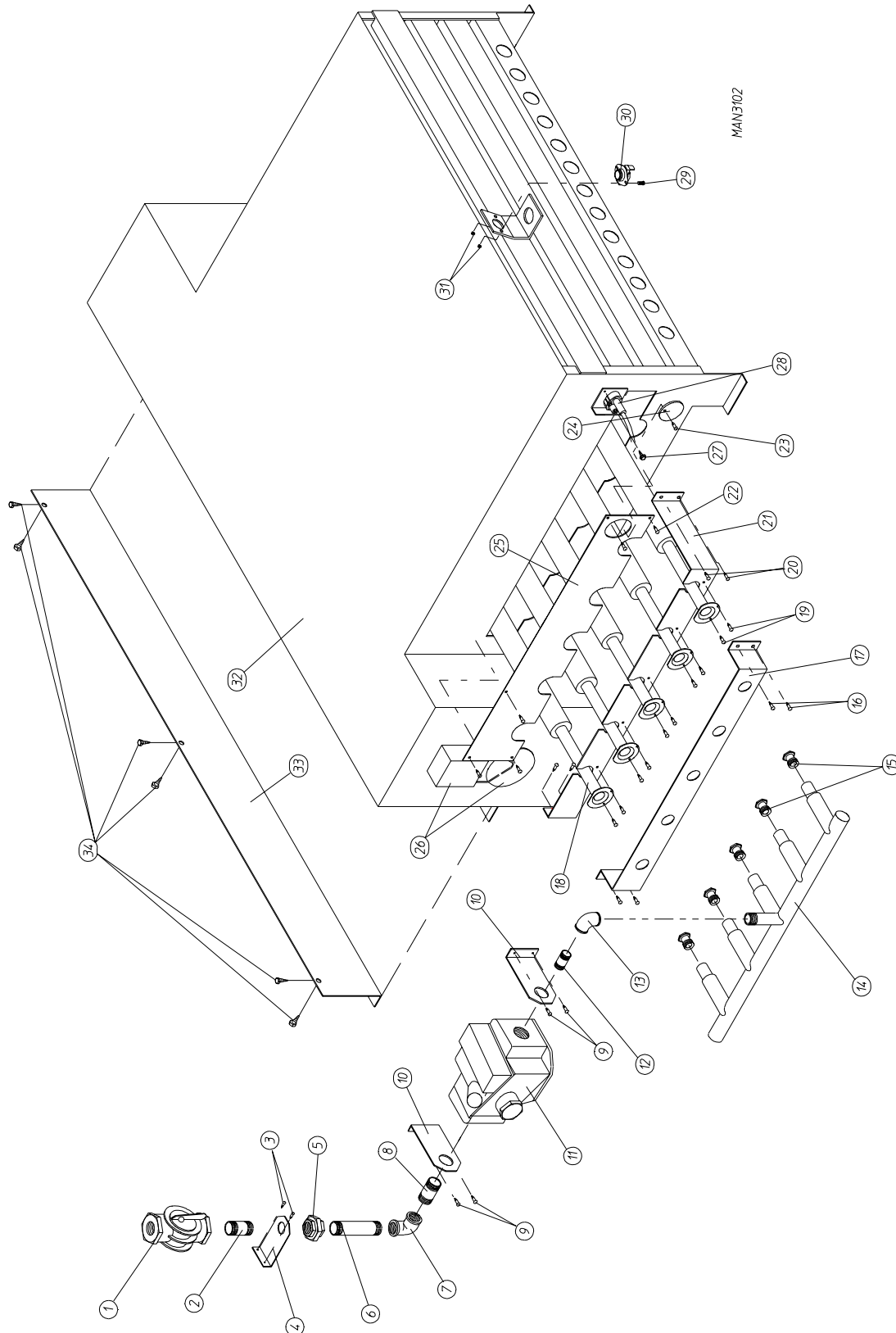

<u>Illus. No.</u>	<u>Part No.</u>	<u>Qty.</u>	<u>Description</u>
1	141302	1	1" Shut-Off Valve
2	142711	1	1" Close Nipple
3	150301	2	#8-18 x 7/16" Phillips Pan Head TEK Screw
4	332605	1	Short Pipe Bracket
5	142602	1	1" Union
6	142584	1	1" x 4-1/2" Nipple
7	142548	1	1" x 90° Elbow
8	142711	1	1" Close Nipple
9	150301	2	#8-18 x 7/16" Phillips Pan Head TEK Screw
10	332604	1	Long Pipe Bracket
11	140017	1	1" x 1" 24 VAC Gas Valve
	140018	1	1" 24 VAC Gas Valve L.P. Conversion Kit
12	142711	1	1" Close Nipple
13	142548	1	1" x 90° Elbow
14	141244	1	5-Port Manifold
15*	140840	5	#1 Burner Orifice (for Natural Gas models mfd. as of March 2, 1992)
	140839	5	#2 Burner Orifice (for Natural Gas models mfd. prior to March 2, 1992)
	140821	5	#28 Burner Orifice (for L.P. Gas models mfd. as of March 2, 1992)
	140820	5	#29 Burner Orifice (for L.P. Gas models mfd. prior to March 2, 1992)
16	150301	4	#8-18 x 7/16" Phillips Pan Head TEK Screw
17	332606	1	Manifold Rest
18	141110	5	Burner Tube
19	150301	10	#8-18 x 7/16" Phillips Pan Head TEK Screw
20	150301	4	#8-18 x 7/16" Phillips Pan Head TEK Screw
21	332607	1	Burner Tube Rest
22	150301	5	#8-18 x 7/16" Phillips Pan Head TEK Screw
23	150301	1	#8-18 x 7/16" Phillips Pan Head TEK Screw
24	331290	1	Sight Hole Disc
25	332597	1	Burner Box Cover Plate
26	-----	1	Sail Switch (refer to <b>Sail Switch Assembly</b> on <b>page 51</b> )
27	150415	2	#10-16 x 1/2" Phillips Round Head Crimptite Screw
28	880943	1	Ignitor/Flame Probe Assembly Kit
	880330	1	DSI Ignitor HV (High Voltage) Wire/Connector ONLY
	305410	1	DSI (Direct Spark Ignition) Gap Feeler Gauge
29	150001	2	#6-32 x 1/2" Round Head Machine Screw
30	130401	1	330° High Limit ONLY
31	151000	2	#6-32 Pal Nut
32**	880789	1	ADG-200 Burner Box ONLY
	880790	1	ADG-200 Natural Gas Burner Box Assembly Complete less Orifices (includes illus. nos. 1 through 14 and 16 through 32)
	880791	1	ADG-200 L.P. Gas Burner Box Assembly Complete less Orifices (includes illus. nos. 1 through 14 and 16 through 34)
---	880754*	1	ADG-200 DSI L.P. Conversion Kit
33***	332622	1	ADG-200 Burner (Left Side) Baffle/Cover
34***	150309	6	#10-16 x 1/2" Hex Head TEK Crimptite Screw

\* Contact factory for elevations over 2,000 feet.

\*\* Orifices are not included and **must be** ordered separately.

\*\*\* For use on models with L.P. Gas ONLY.

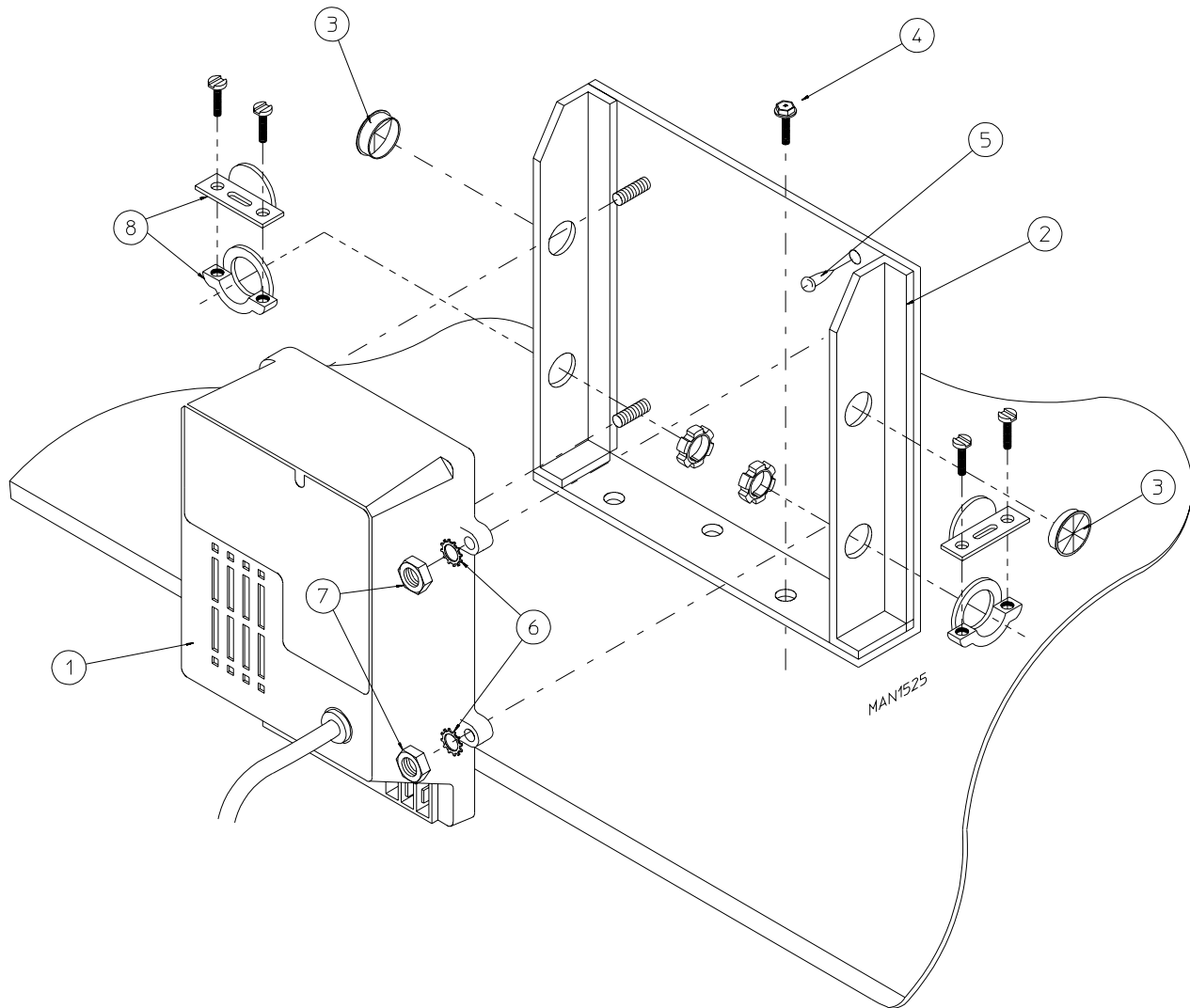

<u>Illus. No.</u>	<u>Part No.</u>	<u>Qty.</u>	<u>Description</u>
1	880815	1	<b>ADC DSI (Direct Spark Ignition) Module ONLY - 50/60 Hz</b>
2	820100	1	<b>ADG-200 DSI Module Mount Assembly ONLY</b>
3	121400	3	Universal Bushing
4	150522	3	1/4-20 x 1/2" Hex Head TEK Screw
5	150301	1	#8-18 x 7/16" Phillips Pan Head TEK Screw
6	153010	4	#6 Star Washer
7	152000	4	#6-32 Hex Nut
8	120102	2	3/8" Straight x 1/2" Knock-Out Connector

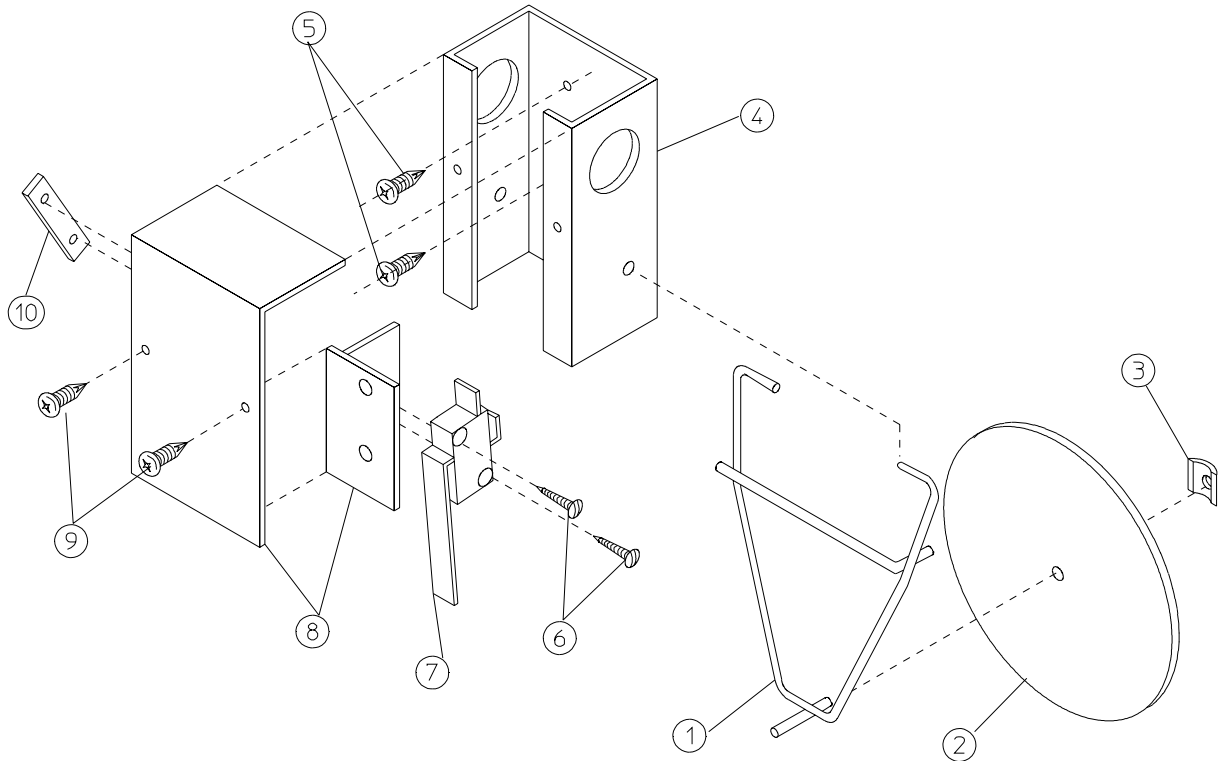

MAN0440

<u>Illus. No.</u>	<u>Part No.</u>	<u>Qty.</u>	<u>Description</u>
1	105500	1	Sail Switch Actuator Rod
2	332689	1	Sail Switch Damper (flat)
3	154002	1	1/8" Push-on Fastener
4	802800	1	Sail Switch Box with Cover and Bracket ONLY (includes illus. nos. 4 and 8)
	880793	1	Sail Switch Box Assembly Complete (includes illus. nos. 1 through 4 and 6 through 10)
5	150300	2	#10 x 1/2" Hex Washer TEK Screw
6	150303	2	#4 x 3/4" Pan Head "A" Machine Screw
7	122200	1	Sail Switch ONLY
8	802799	1	Sail Switch Box Cover and Bracket ONLY
9	150415	2	#10-16 x 1/2" Phillips Round Head Crimptite Screw
10	154004	1	Twin Speed Nut

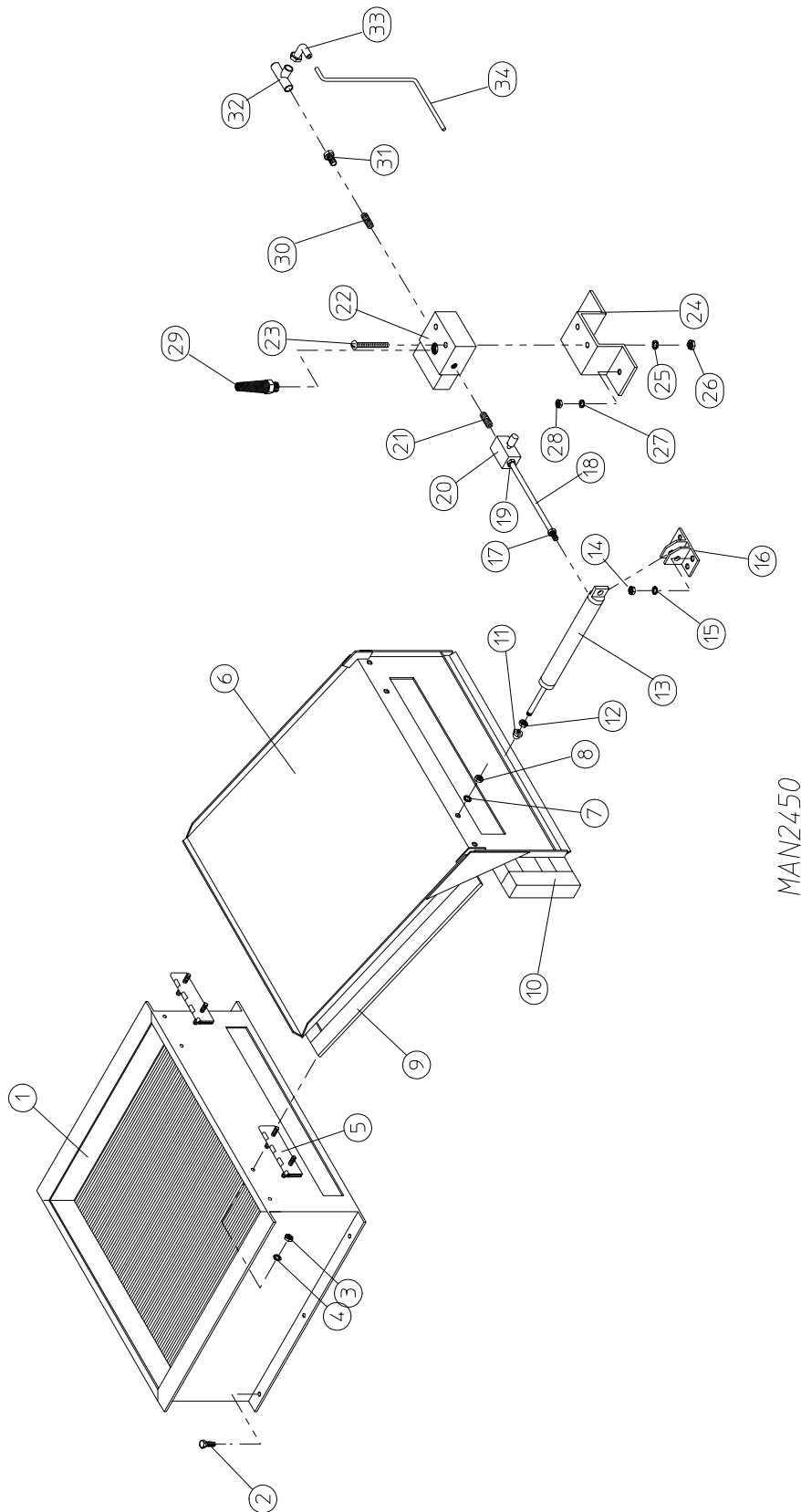

MAN2450

<u>Illus. No.</u>	<u>Part No.</u>	<u>Qty.</u>	<u>Description</u>
1	165020	1	ADS-200 Steam Coil Assembly
2	150523	6	1/4-20 x 3/4 Hex Head Machine Bolt
3	152002	4	1/4-20 Hex Nut
4	153007	4	1/4" Lock Washer
5	820321	2	Steam Damper Hinge Assembly
6	880792	1	Steam Damper Assembly (includes illus. nos. 6, 9, and 10)
7	153007	4	1/4" Lock Washer
8	152002	4	1/4-20 Hex Nut
9	115995	108	Steam Damper Gasket (sold by the inch)
10	102305	1	Steam Damper Foam (68-1/2 length)
11	151008	1	5/8-18 Stainless Steel Acorn Nut (for models mfd. as of March 15, 1992)
	151007	1	7/16-20 Stainless Steel Acorn Nut (for models mfd. prior to March 15, 1992)
12	152030	1	5/8-18 Jam Nut (for models mfd. as of March 15, 1992)
	152007	1	7/16-20 Jam Nut (for models mfd. prior to March 15, 1992)
13	100525	1	2" x 4" Stroke Piston (for models mfd. as of March 15, 1992)
	100502	1	1-1/2" x 4" Stroke Piston (for models mfd. prior to March 15, 1992)
14	152002	4	1/4-20 Hex Nut
15	153007	4	1/4" Lock Washer
16	100526	1	Piston Support (for models mfd. as of March 15, 1992)
	100500	1	Piston Support (for models mfd. prior to March 15, 1992)
17	105609	1	1/4" Poly x 1/4" M.P.T. Connector (for models mfd. as of March 15, 1992)
	100472	1	1/4" Poly x 1/8" M.P.T. Connector (for models mfd. prior to March 15, 1992)
18	143115	1	1/4" Poly Tubing (sold by the foot)
19	100472	1	1/4" Poly x 1/8" M.P.T. Connector
20	100496	1	1/8" Needle Valve
21	143238	1	1/8" Brass Closed Nipple
22	100498	1	3-Way Micro Valve
23	150002	2	#6-32 x 1" Phillips Round Head Machine Screw
24	330987	1	Micro Valve Support Bracket
25	153010	2	#6 Star Washer
26	152000	2	#6-32 Hex Nut
27	153007	2	1/4" Lock Washer
28	152002	2	1/4-20 Hex Nut
29	100520	1	1/8" N.P.T. Silencer (muffler)
30	153238	1	1/8" Brass Closed Nipple
31	143264	1	1/4" x 1/8" Reducing Bushing
32	143219	1	1/4" Brass Tee
33	143153	1	1/4" Poly x 1/4" M.P.T. Elbow
34	143115	1	1/4" Poly Tubing (sold by the foot)

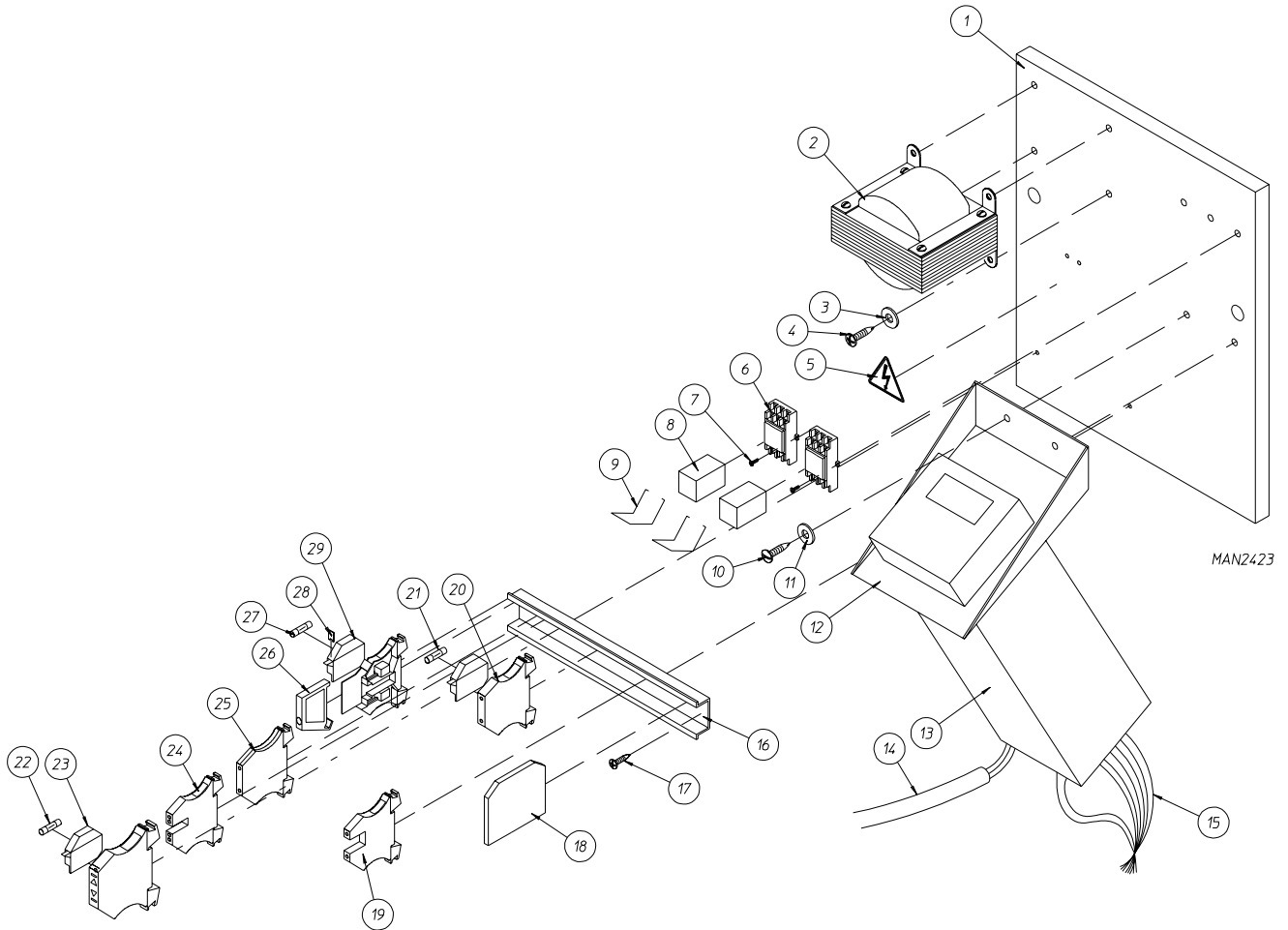



<u>Illus. No.</u>	<u>Part No.</u>	<u>Qty.</u>	<u>Description</u>
1	334259	1	Sprinkler Electrical Panel
2	132091	1	208/240 Volt Transformer
	132092	1	380 Volt Transformer
	132006	1	416 Volt Transformer
	132078	1	480 Volt Transformer
3	153000	4	#8 Flat Washer
4	150108	4	#8-32 x 3/4" Phillips Head Machine Screw
5	122424	1	"POWER WARNING" Caution Label
6	131408	2	Relay Socket
7	150103	3	#8-32 x 3/4" Phillips Head Machine Screw
8	131405	2	DPDT (Double-Pole-Double-Throw) Plug In Relay
9	131409	2	Hold Down Spring
10	150108	2	#8-32 x 1/2" Phillips Head Machine Screw
11	153000	2	#8 Steel Burr
12	333002	1	Temperature Controller Mounting Bracket
13	881249	1	Sprinkler Digital Temperature Control Assembly Complete with Harnesses (includes illus. nos. 13 through 15)
	128964	1	Sprinkler Digital Temperature Control
14	881251	1	Sprinkler Temperature Control RTD (Resistive Temperature Device) Harness
15	881250	1	Sprinkler Temperature Control Power Harness
16	120768	-	Din Mounting Rail (sold by the inch)
17	150415	2	#10-16 x 1/2" Phillips Head Crimptite Screw
18	120766	1	End Section
19	120758	7	Feed Thru Terminal Block
20	120754	1	Fuse Terminal Block with LED
21	136039	1	250 mA (Slo Blo) Fuse
22	136033	1	3-Amp Fuse
23	120756	1	1/4" Fuse Terminal Block with LED
24	120761	4	4-Position Feed Thru Terminal Block
25	120750	1	Ground Terminal Block
26	120765	1	End Stop
27	136050	2	1-Amp (Slo Blo) Fuse - for 208/240 Volt Models
	136057	2	1/2-Amp (Slo Blo) Fuse - for 380-460 Volt Models
28	120999	*	Blank Marking Tab
29	120721	2	Disconnect Fuse Block

\* As required.

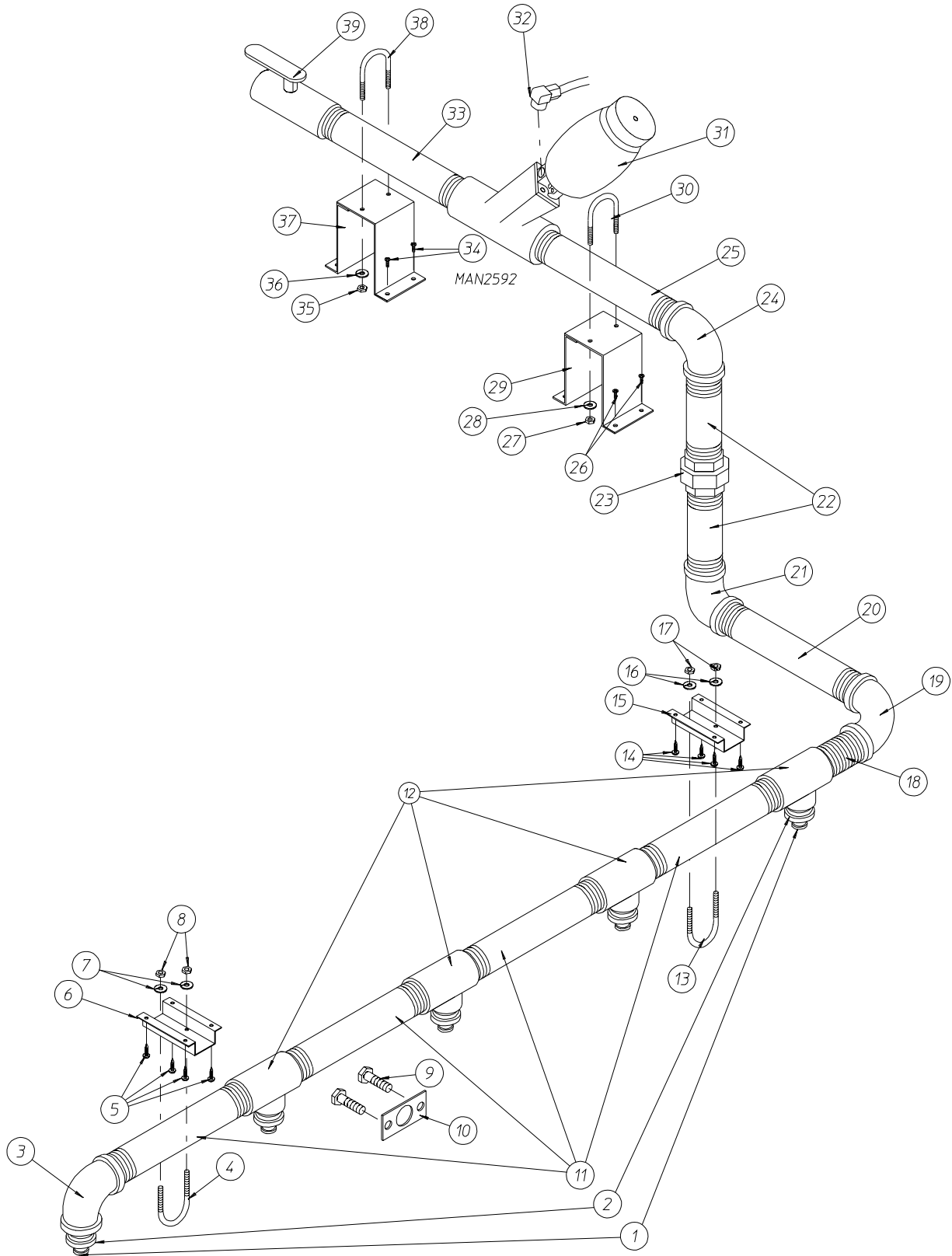

<u>Illus. No.</u>	<u>Part No.</u>	<u>Qty.</u>	<u>Description</u>
1	140927	5	1/4" Sprinkler Nozzle
2	142926	5	1" x 1/4" Reducing Bushing
3	142548	1	1" x 90° Elbow
4	154350	1	1" Pipe U-Bolt
5	150415	4	#10-16 x 1/2" Phillips Head Crimptite Screw
6	332941	1	Inner Pipe Bracket
7	153007	2	1/4" Lock Washer
8	153002	2	1/4-20 Hex Nut
9	150523	2	1/4-20 x 3/4" Hex Washer Machine Bolt
10	331877	1	Temperature Sensor Mounting Plate
11	142581	4	1" x 5" Nipple
12	142508	4	1" Tee
13	154350	1	1" Pipe U-Bolt
14	150415	4	#10-16 x 1/2" Phillips Head Crimptite Screw
15	332941	1	Inner Pipe Bracket
16	153007	2	1/4" Lock Washer
17	153002	2	1/4-20 Hex Nut
18	142711	1	1" Close Nipple
19	142548	1	1" x 90° Elbow
20	142581	4	1" x 5" Nipple
21	142548	1	1" x 90° Elbow
22	142724	2	1" x 2" Nipple
23	142602	1	1" Union
24	142548	1	1" x 90° Elbow
25	142581	1	1" x 5" Nipple
26	150415	4	#10-16 x 1/2" Phillips Head Crimptite Screw
27	153002	2	1/4-20 Hex Nut
28	153007	2	1/4" Lock Washer
29	821640	1	Top Pipe Bracket
30	154350	1	1" Pipe U-Bolt
31	100565	1	1" Air Operated Sprinkler Valve (for models mfd. as of July 22, 1996)
	881414	1	1" Air Operated Sprinkler Valve (replaces Part No. 100557) Used on models mfd. prior to July 22, 1996 (includes illus. nos. 31 and 32)
32	143277	1	1/4" Compression Fitting x 1/8" M.P.T. Elbow (for models mfd. as of July 22, 1996)
	143210	1	1/4" Compression Fitting x 1/4" M.P.T. Elbow (for models mfd. prior to July 22, 1996)
33	142581	1	1" x 5" Nipple
34	150415	4	#10-16 x 1/2" Phillips Head Crimptite Screw
35	153002	2	1/4-20 Hex Nut
36	153007	2	1/4" Lock Washer
37	821640	1	Top Pipe Bracket
38	154350	1	1" Pipe U-Bolt
39	143556	1	1" Ball Valve

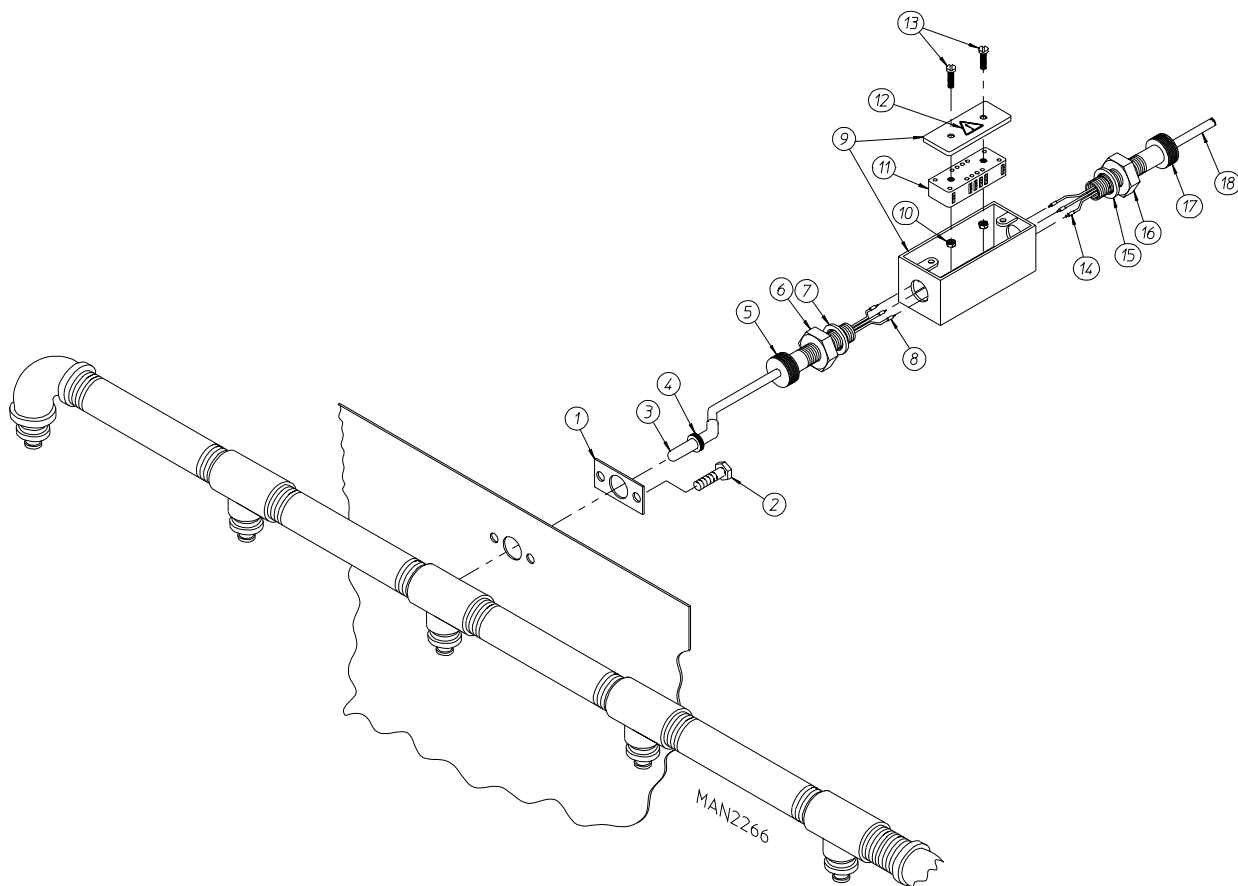

Illus. No.	Part No.	Qty.	Description
1	331877	1	Temperature Sensor Mounting Plate
2	150523	2	1/4-20 x 3/4" Hex Washer Machine Bolt
3	881227	1	RTD (Resistive Temperature Device) Temperature Probe Assembly (includes illus. nos. 3, 4, and 8)
4	143296	1	1/4" Compression Fitting
5	120652	1	1/2" N.P.T. Cord Grip (Red)
6	120915	1	1/2" N.P.T. Lock Nut
7	120914	1	1/2" Metal "O" Ring
8	122736	3	Yellow Ferrule
9	881228	1	Sprinkler Temperature Probe Box Assembly (includes illus. nos. 9 and 12)
10	152000	2	#6-32 Hex Nut
11	120703	1	6-Position Terminal Block
12	122427	1	"!" Caution Label
13	150008	2	#6-32 x 1-1/4" Phillips Round Head Machine Screw
14	122736	3	Yellow Ferrule
15	120914	1	1/2" Metal "O" Ring
16	120915	1	1/2" N.P.T. Lock Nut
17	120650	1	1/2" N.P.T. Cord Grip (White)
18	881229	1	Sprinkler Temperature Probe Harness

**2 AUTOMATIC DOORS**

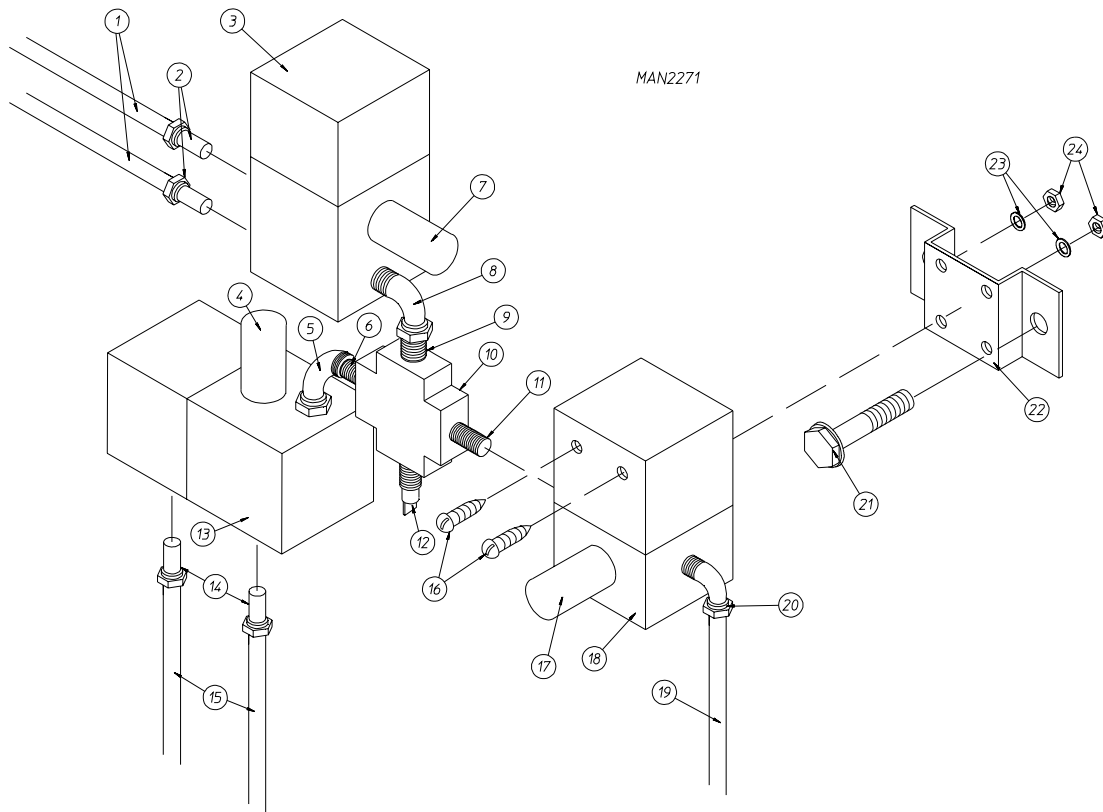

<u>Illus. No.</u>	<u>Part No.</u>	<u>Qty.</u>	<u>Description</u>
1	143115	-	1/4" Poly Flow Tubing (sold by the foot)
2	100472	2	1/4" Poly x 1/8" M.P.T. Connector
3	100468	1	4-Way Valve - 24 VAC
4	100520	1	1/8" Muffler
5	143268	1	1/8" Brass Street Elbow
6	143238	1	1/8" Close Nipple
7	100520	1	1/8" Muffler
8	143268	1	1/8" Brass Street Elbow
9	143238	1	1/8" Close Nipple
10	143237	1	1/8" Brass Cross
11	143238	1	1/8" Close Nipple
12	143250	1	1/8" Brass Plug
13	100468	1	4-Way Valve - 24 VAC
14	100472	2	1/4" Poly x 1/8" M.P.T. Connector
15	143115	-	1/4" Poly Flow Tubing (sold by the foot)
16	150002	2	#6-32 x 1" Phillips Round Head Machine Screw
17	100520	1	1/8" Muffler
18	100498	1	3-Way Valve 24 Volt
19	143115	-	1/4" Poly Flow Tubing
20	143149	1	1/4" Poly x 1/8" M.P.T. Connector Elbow
21	150522	2	1/4-20 x 1/2" Hex Washer TEK Screw
22	330987	1	Valve Mounting Bracket
23	153010	2	#6 Star Washer
24	152000	2	#6-32 Hex Nut

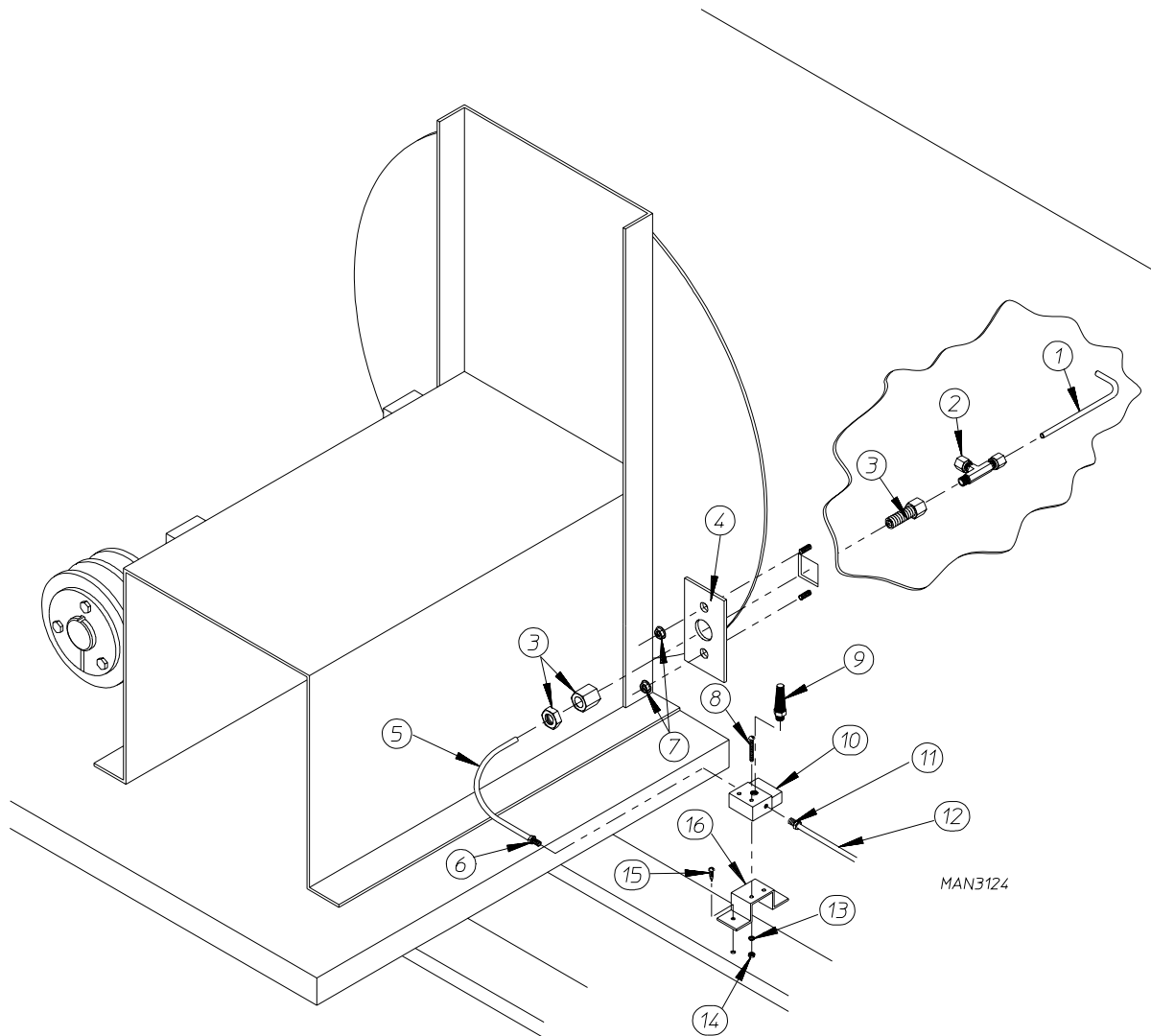

<u>Illus. No.</u>	<u>Part No.</u>	<u>Qty.</u>	<u>Description</u>
1	332770	1	Air Jet Tube
2	143287	1	1/4" x 1/8" M.P.T. Tee
3	143259	1	1/4" Compression x 1/8" F.P.T. Bulkhead Fitting
4	332531	1	Air Jet Mounting Plate
5	143100	1	1/4" Dia. Aluminum Tube (sold by the foot)
6	143152	1	1/4" Compression x 1/8" M.P.T. Straight Connector
7	152014	2	1/4-20 Free Spin Wash Nut
8	150002	1	#6-32 x 1" Phillips Round Head Machine Screw
9	100520	1	1/8" N.P.T. Silencer/Muffler
10	100498	1	3-Way Micro Valve
11	100472	1	1/4" Poly x 1/8" M.P.T. Connector
12	143110	10	1/4" Poly Flow Tubing (sold by the foot)
13	153010	2	#6 Star Washer
14	152000	2	#6-32 Hex Nut
15	150415	2	#10-16 x 1/2" Phillips Round Head Crimpite Screw
16	330987	1	Micro Valve Support Bracket

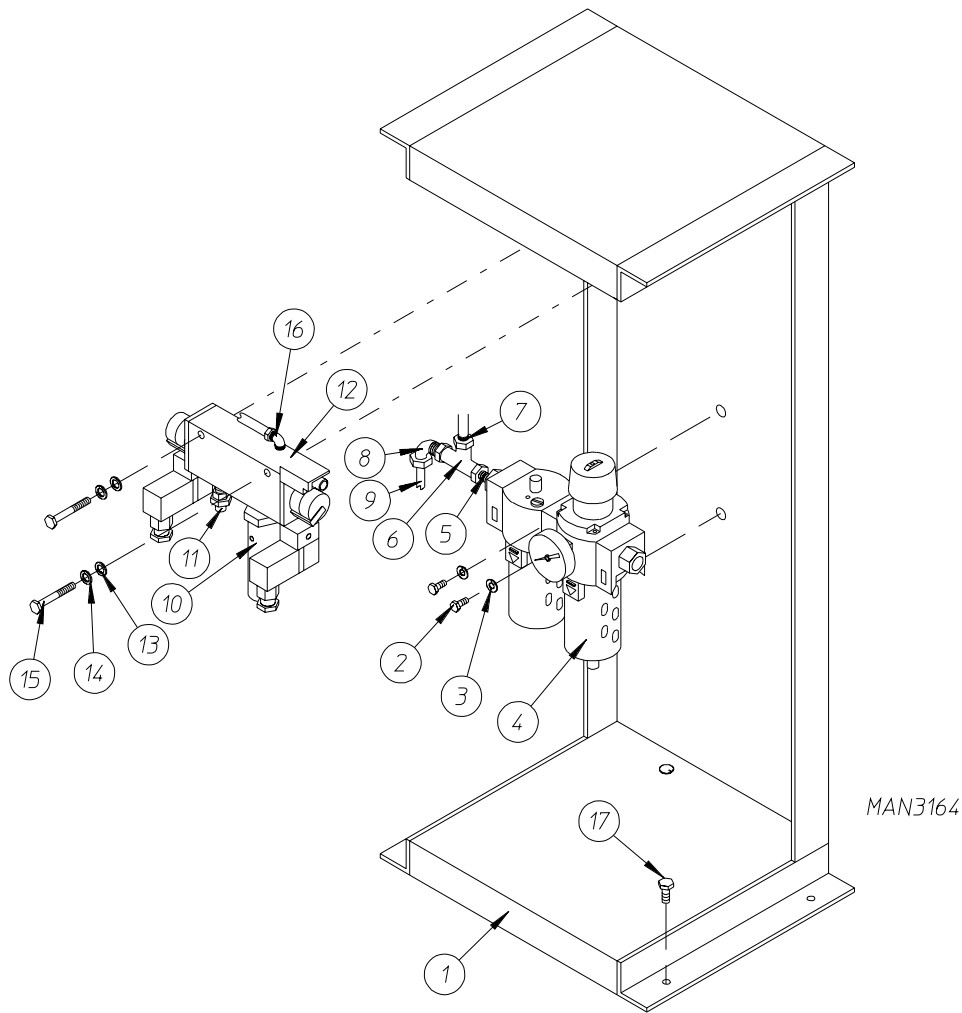

MAN3164

<u>Illus. No.</u>	<u>Part No.</u>	<u>Qty.</u>	<u>Description</u>
1	821639	1	Sprinkler Pneumatic Mount Weldment
2	150512	2	1/4-20 x 1/2" Hex Head Machine Bolt
3	153007	2	1/4" Lock Washer
4	100516	1	Filter/Regulator/Lubricator (F/R/L) Gauge
5	143241	1	3/8" Close Nipple
6	143220	1	3/8" Tee
7	143283	1	3/8" Poly x 3/8" M.P.T. Connector
8	143290	1	1/4" Poly x 3/8" M.P.T. Elbow
9	143120	1	3/8" Poly Flow Tubing (sold by the foot)
10	100482	1	3/8" Silencer
11	143283	1	3/8" Poly x 3/8" M.P.T. Connector
12	100556	1	3-Way/2 Position/ 3 Port Sprinkler Solenoid
13	153018	4	1/4" Flat Washer
14	153007	2	1/4" Lock Washer
15	150524	2	1/4-20 x 2" Hex Head Bolt
16	143151	1	1/4" Compression x 3/8" M.P.T. Elbow
17	150522	2	1/4-20 x 1/2" Hex Washer TEK Screw

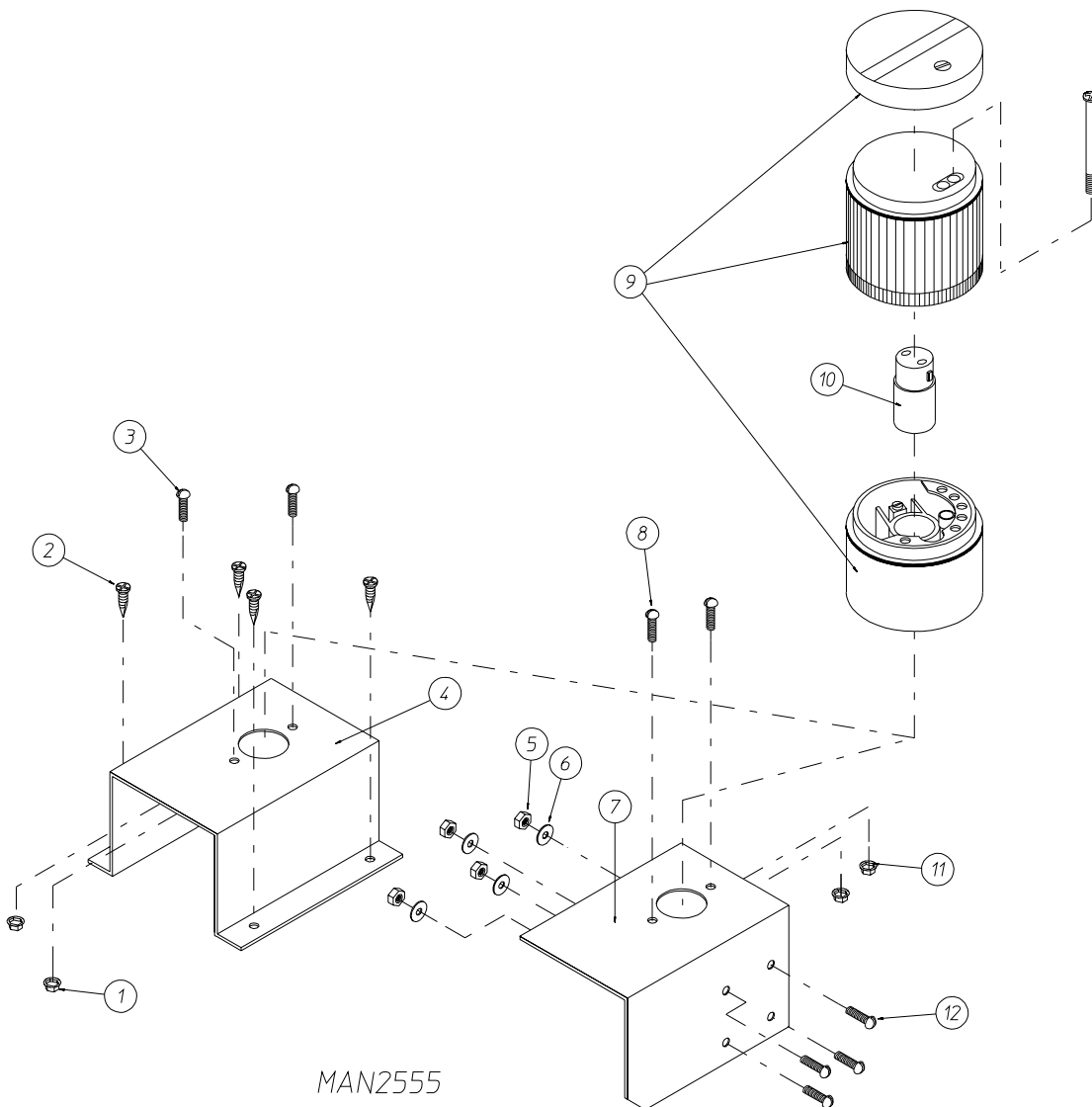

<u>Illus. No.</u>	<u>Part No.</u>	<u>Qty.</u>	<u>Description</u>
1	151001	2	#8-32 Pal Nut
2	150415	4	10-16 x 1/2" Phillips Round Head Crimpite Screw
3	150108	2	#8-32 x 1/2" Phillips Pan Head Machine Screw
4*	821480	1	Cycle Light Bracket (for Steam Models ONLY)
5	152001	4	#8-32 Hex Nut
6	153012	4	#8 Star Washer
7*	332850	1	Cycle Light Bracket (for Gas Models ONLY)
8	150108	2	#8-32 x 1/2" Phillips Pan Head Machine Screw
9	123222	1	"ORANGE" Cycle Light
10	123221	1	Bulb - 24 VAC
11	151001	2	#8-32 Pal Nut
12	150108	4	#8-32 x 1/2" Phillips Pan Head Machine Screw

\* Specify color when ordering.



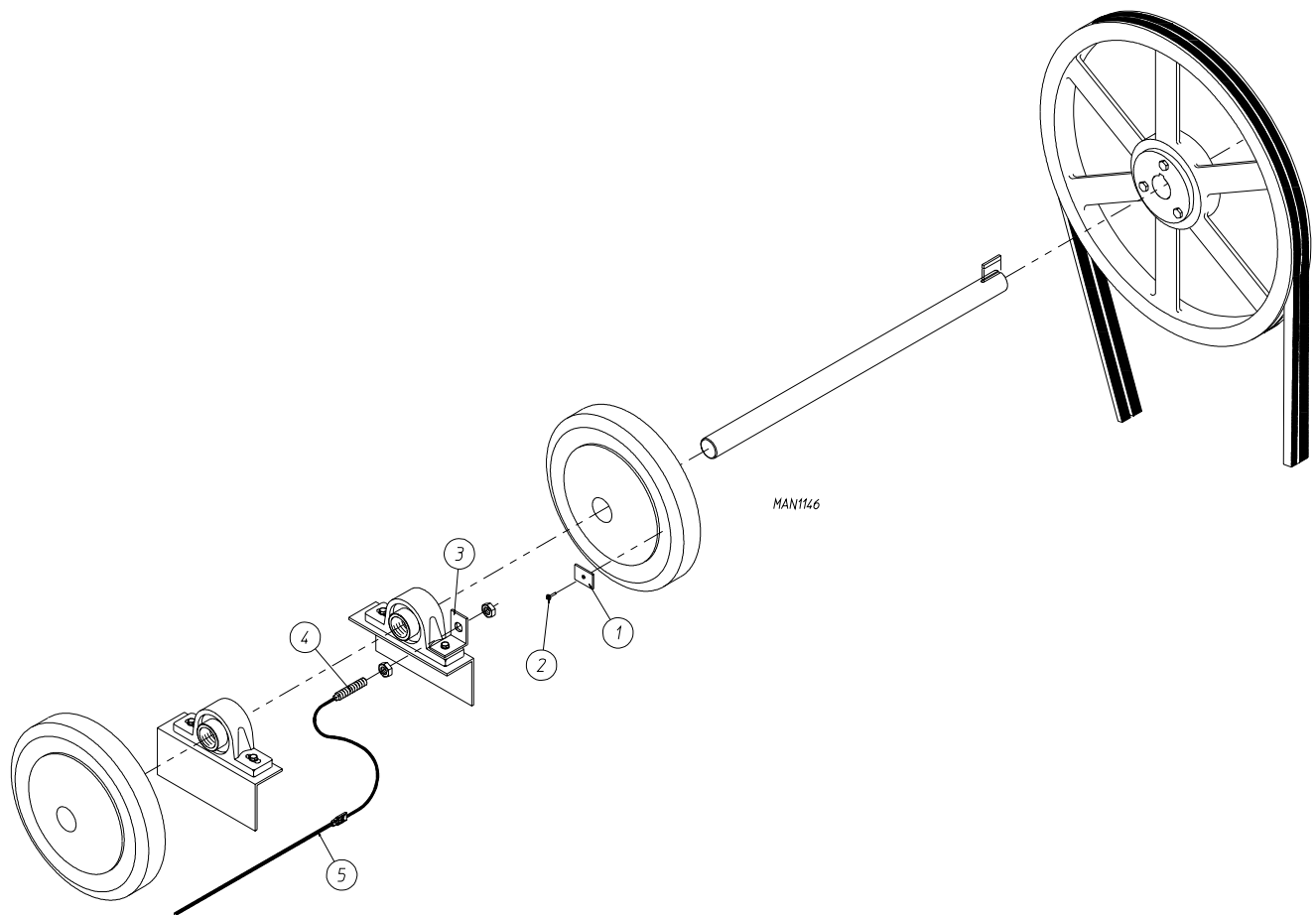

<u>Illus. No.</u>	<u>Part No.</u>	<u>Qty.</u>	<u>Description</u>
1	102102	1	Tumbler Sensor Magnet
2	154200	1	5/32" Pop Rivet
3	332750	1	Rotational Sensor Mounting Bracket
4	824807	1	AD-200 Rotational Sensor Assembly
5	824806	1	AD-200 Rotational Sensor Harness

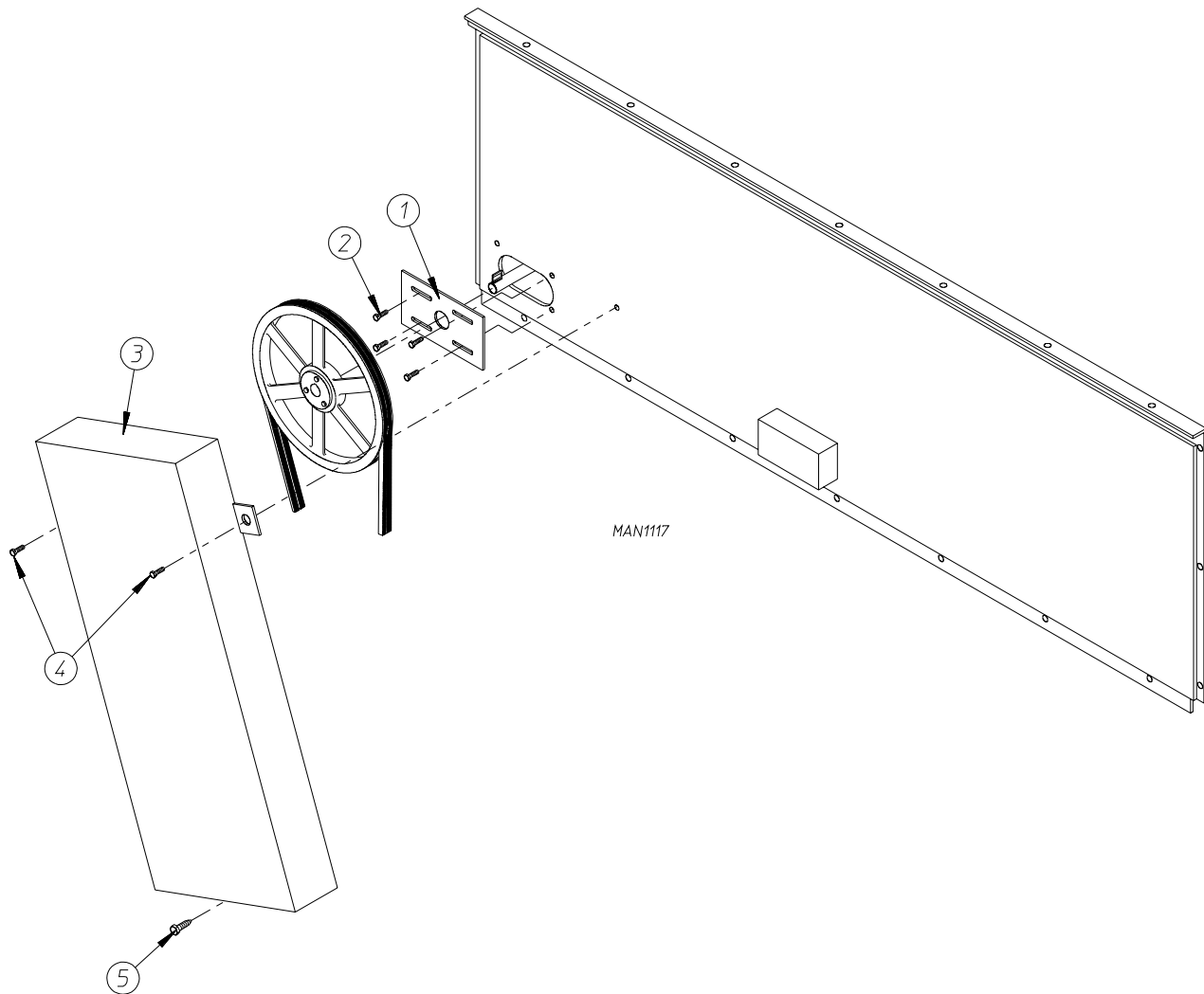

<u>Illus. No.</u>	<u>Part No.</u>	<u>Qty.</u>	<u>Description</u>
1*	880794	1	AD-200 Back Cover Plate
2	150522	4	1/4-20 x 1/2" Hex Washer Machine Bolt
3*	821204	1	Belt Guard
4	150301	2	#8-18 x 7/16" Phillips Pan Head TEK Screw
5	150522	1	1/4-20 x 1/2" Hex Washer Machine Bolt

\* Specify color when ordering.

**For Gas Models mfd. prior to October 2, 1995**  
**For Steam Models mfd. prior to July 20, 1992**

VOLTAGE	FUSE	QTY.	FUSE BLOCK	QTY.	BLOWER MOTOR OVERLOAD	QTY.	BLOWER MOTOR CONTACTOR	QTY.	VARISTOR	QTY.
208	136027	3	136004	1	132439	1	132465	1	132437	1
230	136027	3	136004	1	132439	1	132465	1	132437	1
380	136024	3	136004	1	132435	1	132465	1	132437	1
416	136024	3	136004	1	132435	1	132465	1	132437	1
460	136024	3	136004	1	132435	1	132465	1	132437	1

**For Steam Models mfd. between July 20, 1992 and October 19, 1995**

VOLTAGE	FUSE	QTY.	FUSE BLOCK	QTY.	BLOWER MOTOR OVERLOAD	QTY.	BLOWER MOTOR CONTACTOR	QTY.	VARISTOR	QTY.
208	136091	3	136090	1	132483	1	132480	1	132435	1
230	136091	3	136090	1	132483	1	132480	1	132435	1
380	136092	3	136090	1	132484	1	132481	1	132435	1
416	136093	3	136090	1	132484	1	132481	1	132435	1
460	136094	3	136090	1	132439	1	132465	1	132435	1

**NOTE:** For current Overload/Contactor information refer to **page 24 thru page 27.**

	<b>208 VOLT</b>	<b>240 VOLT</b>	<b>380 VOLT</b>	<b>416 VOLT</b>	<b>460 VOLT</b>	<b>575 VOLT</b>
<b>GAS MODELS</b>	132094	132095	132093	132096	132098	132097
<b>STEAM MODELS</b> FOR MODELS MFD. AS OF <b>MARCH 11, 1997</b>	132071	132072	132073	132074	132075	132076
<b>STEAM MODELS</b> FOR MODELS MFD. PRIOR TO <b>MARCH 11, 1997</b>	<b>881562</b> replaces Part No. 132094	<b>881563</b> replaces Part No. 132095	<b>881564</b> replaces Part No. 132093	<b>881565</b> replaces Part No. 132096	<b>881566</b> replaces Part No. 132098	<b>881567</b> replaces Part No. 132097

**NOTE:** For AD-200 models with Manual Doors the transformer is located on the Left Panel Assembly

For AD-200 models with Automatic Door the transformer is located on the Right Panel Assembly.

ADC 450115 1- 11/09/92-100 2\* 09/03/93-100 3-03/30/95-100  
4\* 04/18/97-100

