



Euro-14 Parts Manual 24 VAC Phase 5 Coin Phase 6 OPL

American Dryer Corporation
88 Currant Road
Fall River, MA 02720-4781
Telephone: (508) 678-9000 / Fax: (508) 678-9447
E-mail: techsupport@amdry.com
www.amdry.com

Retain This Manual In A Safe Place For Future Reference

American Dryer Corporation products embody advanced concepts in engineering, design, and safety. If this product is properly maintained, it will provide many years of safe, efficient, and trouble-free operation.

ONLY qualified technicians should service this equipment.

OBSERVE ALL SAFETY PRECAUTIONS displayed on the equipment or specified in the installation manual included with the dryer.

The following “**FOR YOUR SAFETY**” caution **must be** posted near the dryer in a prominent location.

FOR YOUR SAFETY

Do not store or use gasoline or other flammable vapors and liquids in the vicinity of this or any other appliance.

POUR VOTRE SÉCURITÉ

Ne pas entreposer ni utiliser d'essence ni d'autres vapeurs ou liquides inflammables à proximité de cet appareil ou de tout autre appareil.

We have tried to make this manual as complete as possible and hope you will find it useful. **ADC** reserves the right to make changes from time to time, without notice or obligation, in prices, specifications, colors, and material, and to change or discontinue models.

Important

For your convenience, log the following information:

DATE OF PURCHASE _____ **MODEL NO.** **Euro-14** _____

RESELLER'S NAME _____

Serial Number(s) _____

Replacement parts can be obtained from your reseller or the **ADC** factory. When ordering replacement parts from the factory, you can FAX your order to **ADC** at (508) 678-9447 or telephone your order directly to the **ADC** Parts Department at (508) 678-9000. Please specify the dryer **model number** and **serial number** in addition to the **description** and **part number**, so that your order is processed accurately and promptly.

The illustrations on the following pages may not depict your particular dryer exactly. The illustrations are a composite of the various dryer models. Be sure to check the descriptions of the parts thoroughly before ordering.

“IMPORTANT NOTE TO PURCHASER”

Information **must be** obtained from your local gas supplier on the instructions to be followed if the user smells gas. These instructions **must be** posted in a prominent location near the dryer.

Table of Contents

Control Door Assembly	3
Phase 6 OPL Microprocessor Control Panel Assembly	4
Phase 6 OPL Microprocessor Control Box Assembly	5
Phase 5 Coin Microprocessor Control Panel Assembly	6
Dual Timer Control Panel Assembly	7
Coin and Dual Timer Control Box Assembly	8
Coin Vault Assembly	9
Front Panel Assembly	10
Main Door “Steel” Assembly	11
Main Door Switch Assembly	12
Basket (Tumbler)/Support Assemblies	13
Lint Drawer/Lint Drawer Switch Assemblies	
For Models Mfd. as of September 8, 2000	14
Lint Drawer/Lint Drawer Switch Assemblies	
For Models Mfd. prior to September 8, 2000	15
Idler Bearing Assembly	16, 17
Basket (Tumbler) Bearing Assembly	
For Models Mfd. as of July 17, 2000	18, 19
Basket (Tumbler) Bearing Assembly	
For Models Mfd. prior to July 17, 2000	20, 21
Non-Reversing T.E.F.C. Motor Mount Assembly	22, 23
Reversing T.E.F.C. Motor Mount Assembly	24, 25
Sensor Bracket Assemblies	26, 27
Gas Burner Assembly	28, 29
Electric Oven Assembly	30, 31
Single-Phase (1 ϕ) Motor, Electric Relay Panel Assembly	32

3-Phase (3 ϕ) Motor, Electric Relay Panel Assembly	33
Reversing Electric Relay Panel Assembly	34, 35
Steam Coil/Air Operated Steam Damper Assembly	36, 37
Outer Top/Back Guard Assemblies	38
Microprocessor Coin Acceptors Listing	39
Electrical Oven Component Application Chart	40
Additional Parts Available	41

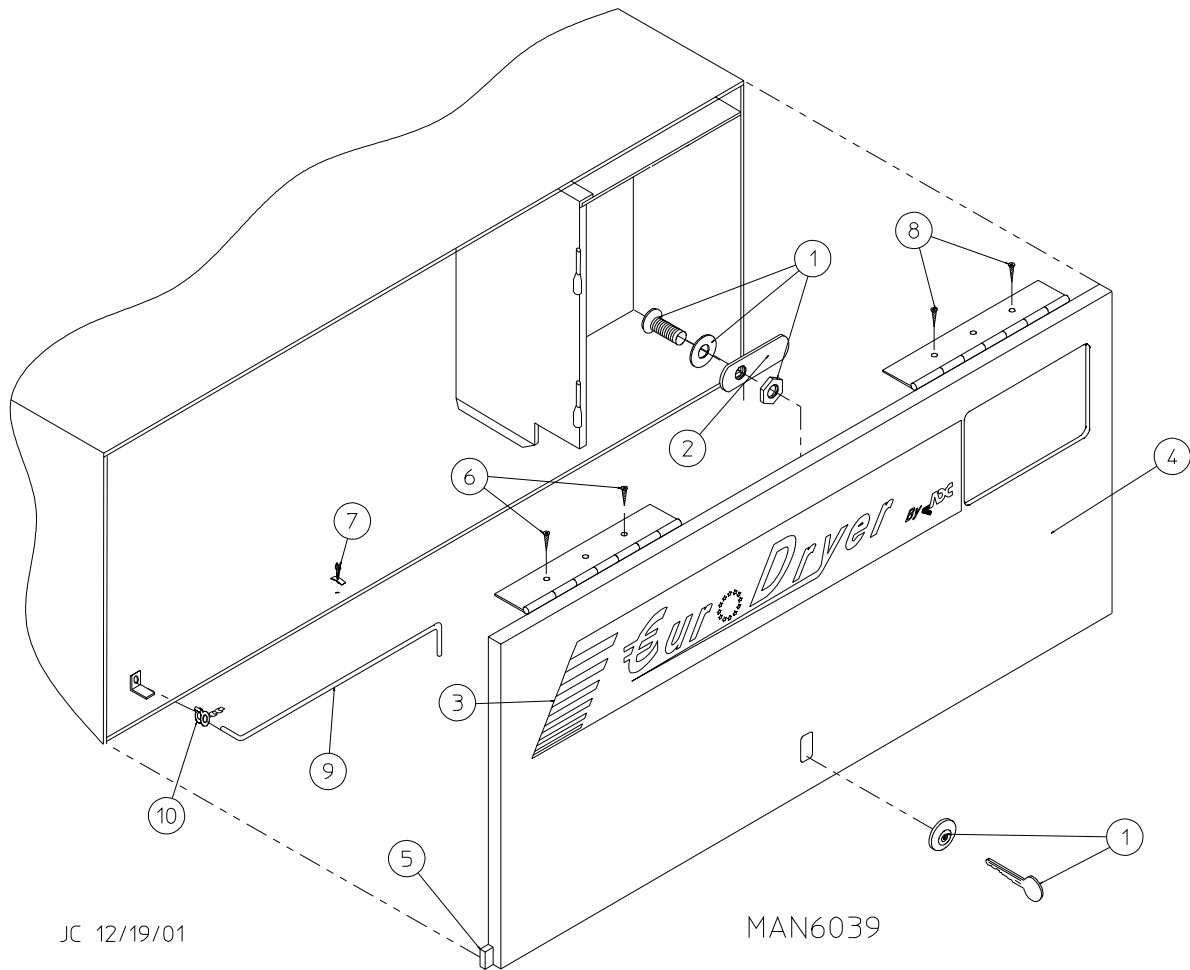

Illus. No.	Part No.	Qty.	Description
1	160015	1	High Security MK-100 Lock Assembly with Key (for coin models Only)
	160017	1	Special Dummy Lock ONLY (for non-coin models Only)
	160104	1	MK-100 Key ONLY
2	160052	1	Lock Cam ONLY
3	112367	1	Euro Logo with Tape
4	882511	1	White Control Door Assembly Less Lock (includes illus. nos. 4 and 5)
	882513	1	Almond B Control Door Assembly Less Lock (includes illus. nos. 4 and 5)
	882512	1	Coral Blue Control Door Assembly Less Lock (includes illus. nos. 4 and 5)
5	117603	3	Noise Suppressor Tape (sold by the foot)
6	150300	2	#10-16 x 1/2" Hex Washer TEK Screw
7	102603	1	Control Door Rod Support Catch
8	150300	2	#10-16 x 1/2" Hex Washer TEK Screw
9	102502	1	Control Door Support Rod
10	102601	1	Control Door Rod Retainer Clip

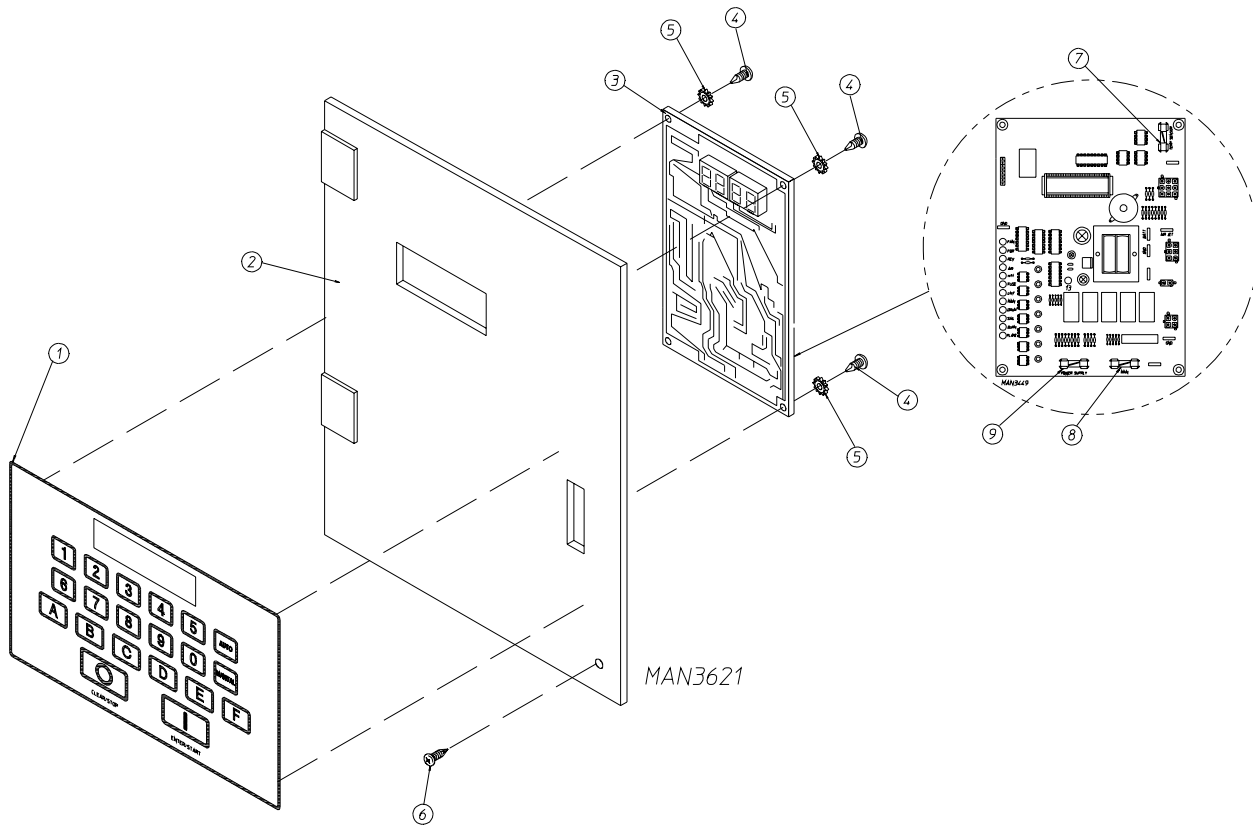

Illus. No.	Part No.	Qty.	Description
1	112537	1	Phase 6 OPL Keyboard
	112276	1	OPL Stick-On Labels (English Only)...Not Illustrated
	112275	1	3-Language OPL Stick-On Labels (Spanish, Italian, and Hebrew)...Not Illustrated
	112277	1	3-Language OPL Stick-On Labels (English, Spanish, and Hebrew)...Not Illustrated
	112278	1	5-Language OPL Stick-On Labels (Italian, Dutch, French, German, and Chinese)...Not Illustrated
2	881745	1	Phase 6 Microprocessor Controller (computer) Panel ONLY
	881747	1	Phase 6 OPL Non-Reversing Computer Panel Assembly Complete (includes illus. nos. 1 through 5 and 7 through 9)
	881746	1	Phase 6 OPL Reversing Computer Panel Assembly Complete (includes illus. nos. 1 through 5 and 7 through 9)
3	137123	1	Phase 6 OPL Non-Reversing Microprocessor Controller (computer) ONLY
	137122	1	Phase 6 OPL Reversing Microprocessor Controller (computer) ONLY
4	150005	3	#6-32 x 3/4" Phillips Round Head Machine Screw
5	153010	3	#6 Star Washer
6	150309	1	#10-16 x 1/2" Hex Head TEK Crimptite Screw
7	136048	1	1/8-Amp (slo blo) Fuse
8	136017	1	3.15-Amp (fast acting) Fuse
9	136019	1	1-Amp (fast acting) Fuse

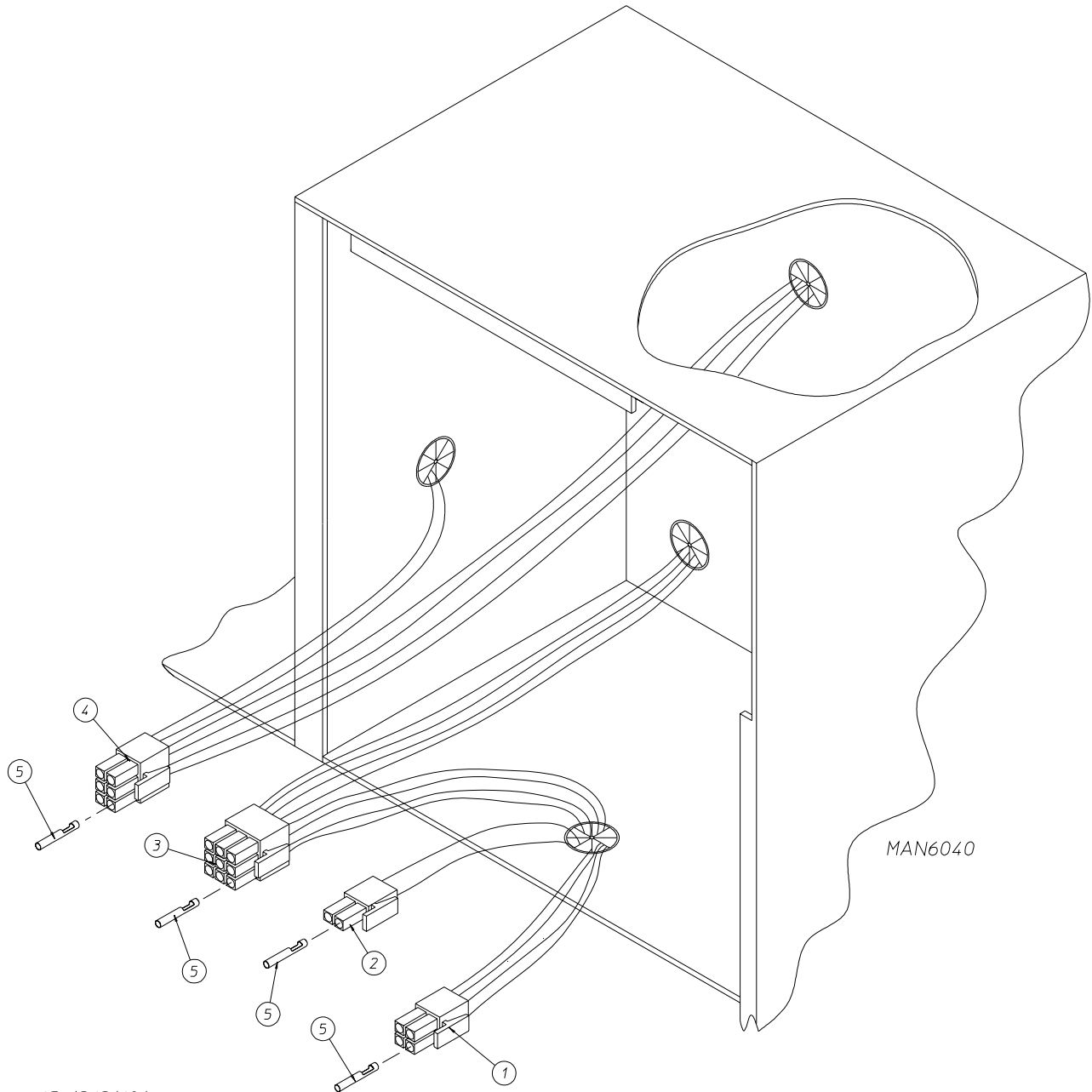

JC 12/21/01

Illus. No.	Part No.	Qty.	Description
1	122648	1	4-Pin Connector
2	122646	1	2-Pin Connector
3	122640	1	9-Pin Connector
4	122644	1	6-Pin Terminal
5	122706	*	Socket Terminal ONLY
--	122801	1	Pin/Socket Extraction Tool

* As needed.

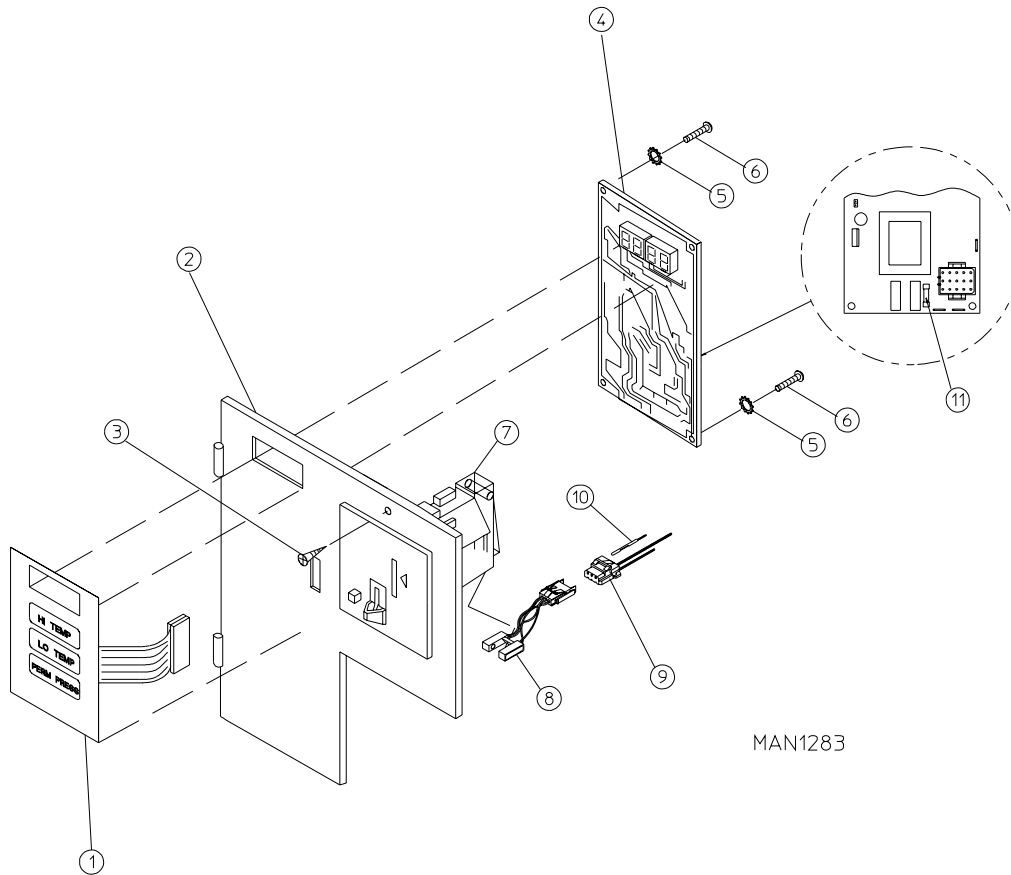

MAN1283

Illus. No.	Part No.	Qty.	Description
1	112526	1	Coin Keyboard Label Assembly
2	801213	1	Phase 5 Coin Control Panel Assembly (includes illus. nos. 1, 2, 4, 5, and 6)
	801229	1	Phase 5 Coin Control Panel Assembly with Battery Option (includes illus. nos. 1, 2, 4, 5, and 6)
	801259	1	Coin Control Panel ONLY
	801258	1	Coin Control Panel ONLY with Battery Bracket
3	150309	1	#10-16 x 1/2" Hex Head TEK Crimptite Screw
4	137213	1	Phase 5 Coin Controller ONLY
	824998	1	Phase 5 Battery Clip
5	153010	2	#6 Star Washer
6	150005	2	#6-32 x 1/4" Phillips Round Head Machine Screw
7	-----	1	Microprocessor Coin Acceptor (refer to Microprocessor Coin Acceptors Listing on page 39)
8	-----	1	Optic Switch ONLY (refer to Microprocessor Coin Acceptors Listing on page 39)
9	137023	1	Optic Switch Connector ONLY
10	137021	3	Microprocessor Socket ONLY
	880772	1	Single Coin Optical Switch Harness
	122800	1	Microprocessor (female) Pin Extraction Tool
11	136048	1	1/8-Amp (slo blo) Fuse

IMPORTANT: Check label on computer chip to verify correct part number of controller (computer).

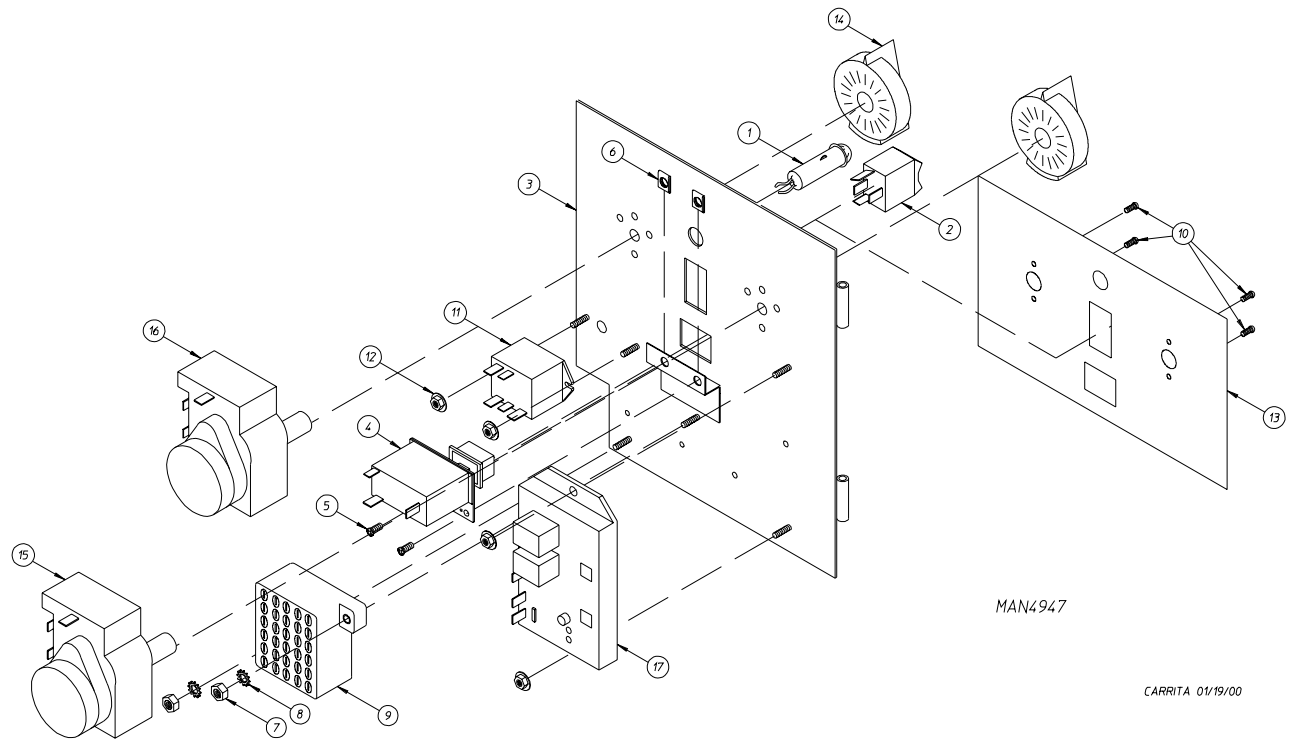

Illus. No.	Part No.	Qty.	Description
1	123005	1	Red Indicator Light - 24 VAC
2	122400	1	Rocker Heat Selector Switch
3	818051	1	Dual Timer Control Panel Assembly Complete - 24 VAC (includes illus. nos. 1 through 16)
	-----*	1	Dual Timer Reversing Control Panel Assembly Complete - 24 VAC (includes illus. nos. 1 through 17)
	850456	1	Dual Timer Control Panel ONLY
4	131917	1	Push-To-Start Relay - 24 VAC
5	150207	2	#10-24 x 1/2" Phillips Pan Head Machine Screw
6	154001	2	#10-24 Speed Nut
7	152000	2	#6-32 Hex Nut
8	153010	2	#6 Star Washer
9	120730	1	30-Position Terminal Block
10	150110	4	#8-32 x 1/4" Phillips Round Head Machine Screw
11	131932	1	Dual Timer Relay - 24 VAC
12	151000	4	#6-32 Pal Nut
13	112050	1	Dual Timer Label ONLY
14	124103	2	Arrow Timer Knob
15	124025	1	60-Minute Timer - 24 VAC
16	124030	1	15-Minute Timer - 24 VAC
17	132198	1	Reversing Timer - 24 VAC

* Not available at time of printing, please contact factory for information.

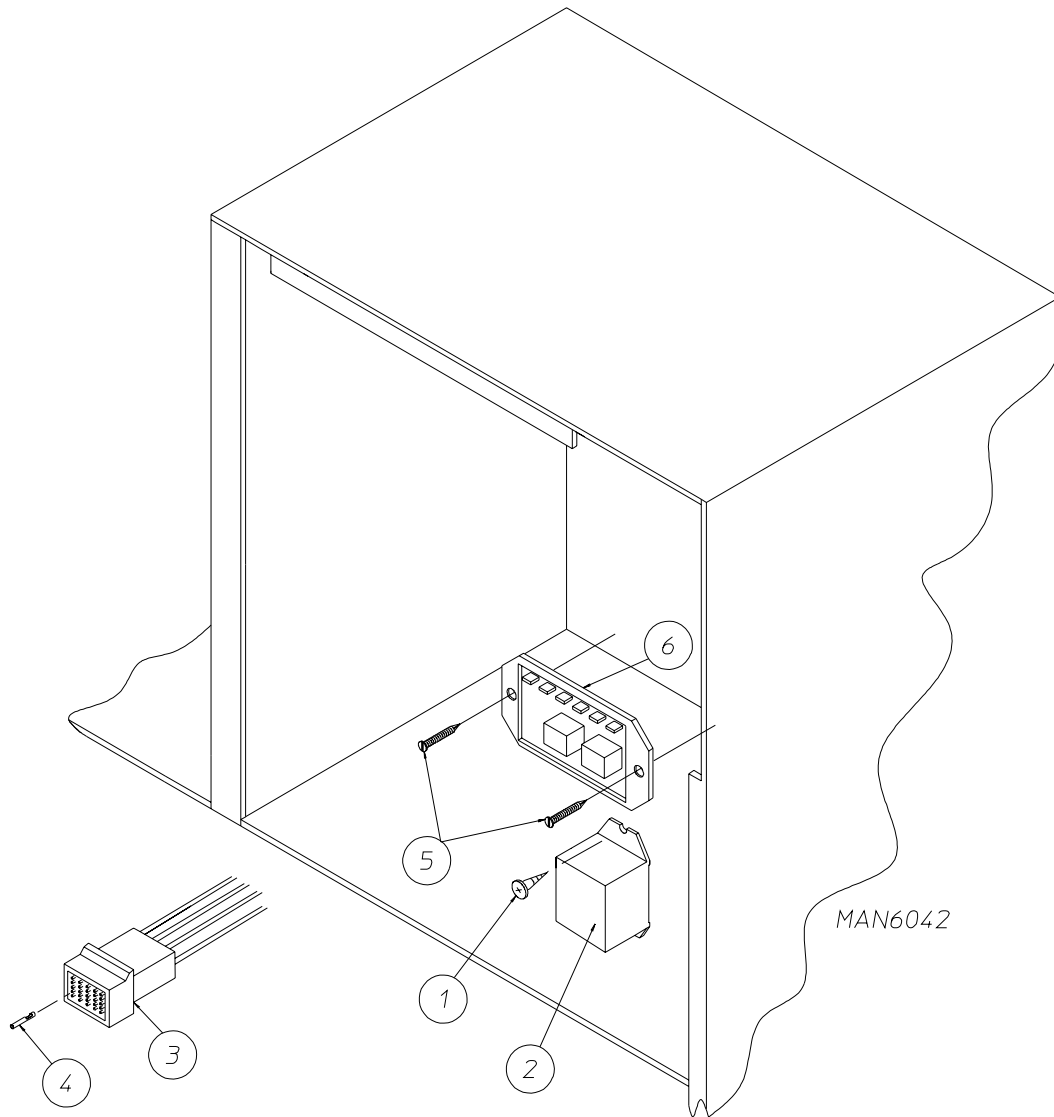

JCARRITA 12/20/01

Illus. No.	Part No.	Qty.	Description
1	150301	2	#8-18 x 7/16" Phillips Pan Head TEK Screw
2	131931	1	Heat Relay - 24 VAC (for dual timer models Only)
3	122641	1	15-Pin Microprocessor Controller (computer) Connector
4	122706	*	Socket Terminal ONLY
--	122801	1	Pin/Socket Extraction Tool
5	150301	2	#8-18 x 7/16" Phillips Pan Head TEK Screw
6	132198	1	Reversing Timer 24v (for reversing dual timer models Only)

* As required.

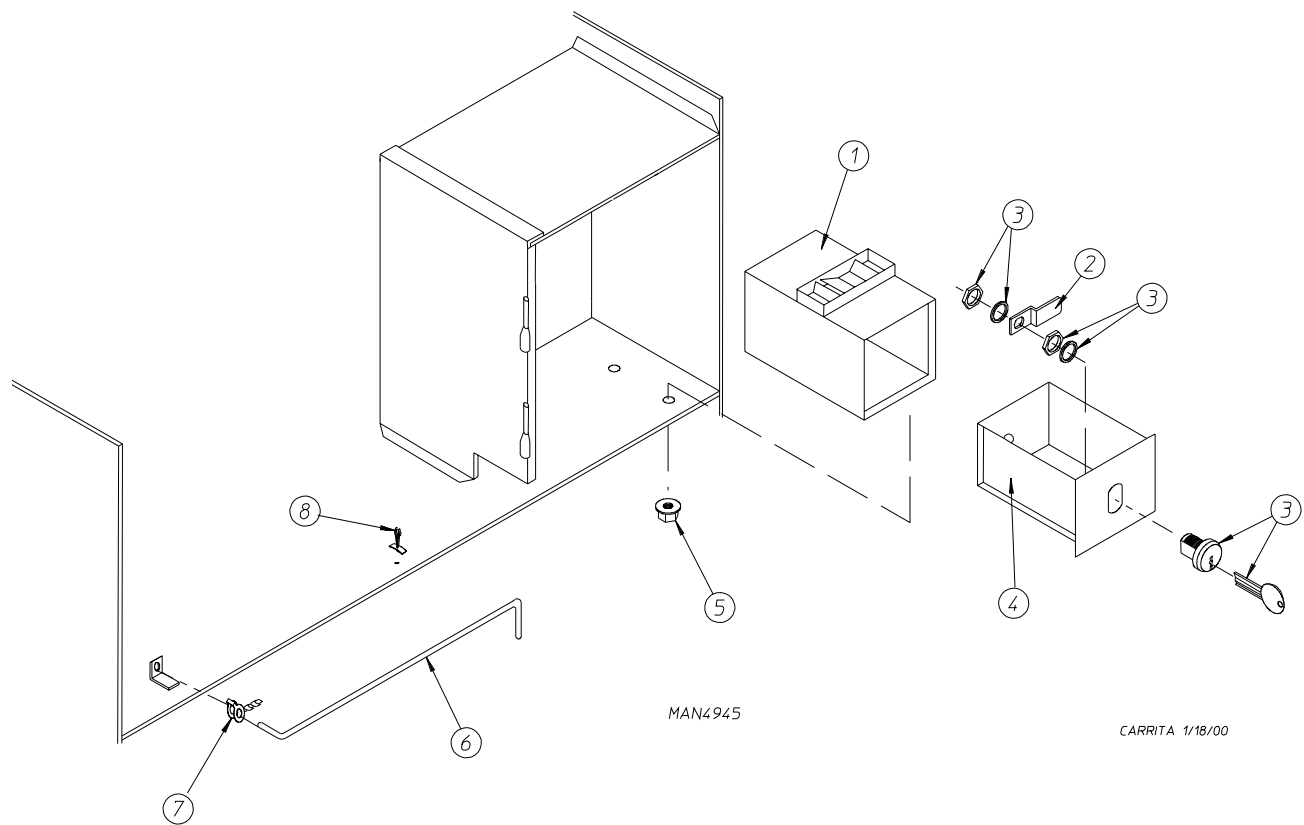

Illus. No.	Part No.	Qty.	Description
1	802112	1	Microprocessor Coin Vault Assembly Complete (includes illus. nos. 1 through 5)
	802117	1	Microprocessor Coin Vault ONLY
	802110	1	Non-Microprocessor Coin Vault Assembly Complete (includes illus. nos. 1 through 5)
	802115	1	Non-Microprocessor Coin Vault ONLY
2	160028	1	Cam for 1/4 Turn Lock ONLY
3	875061	1	1/4 Turn Lock with Key and Cam
	160105*	1	1/4 Turn Mer-Pel Key ONLY
4	802020	1	1/4 Turn Coin Box Assembly (includes illus. nos. 2 through 4)
5	152014	4	1/4-20 Free Spin Wash Nut
6	102502	1	Control Door Support Rod
7	102601	1	Control Door Rod Retainer Clip
8	102603	1	Control Door Rod Catch

* Specify key number when ordering.

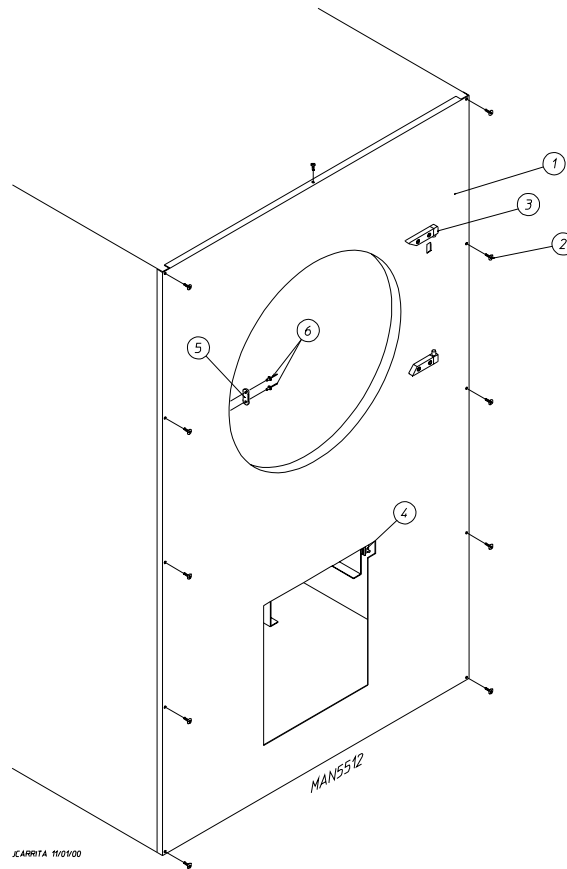

Illus. No.	Part No.	Qty.	Description
1	883137	1	White Front Panel Assembly (includes illus. nos. 1, 5, and 6) (for models mfd. as of January 18, 2000)
	883138	1	Coral Blue Front Panel Assembly (includes illus. nos. 1, 5, and 6) (for models mfd. as of January 18, 2000)
	883139	1	Ivory Front Panel Assembly (includes illus. nos. 1, 5, and 6) (for models mfd. as of January 18, 2000)
	817052*	1	Front Panel (includes illus. nos. 1, 5, and 6) (for models mfd. prior to January 18, 2000)
2	150313	11	#10-16 x 1/2" TORX Plus BTN Type 1
	150318	1	25 IP TORX Plus Bit 1/4 Hex (for removal of TORX head screw)
3	-----	1	Main Door Hinge (refer to Main Door "Steel" Assembly on page 11)
4	-----	1	Lint Drawer Switch (refer to Lint Drawer/Lint Drawer Switch Assemblies on page 14)
5	881987	1	Friction Door Latch (includes illus. nos 5 and 6)
6	154215	2	5/32" Pop Rivet

* Specify color when ordering.

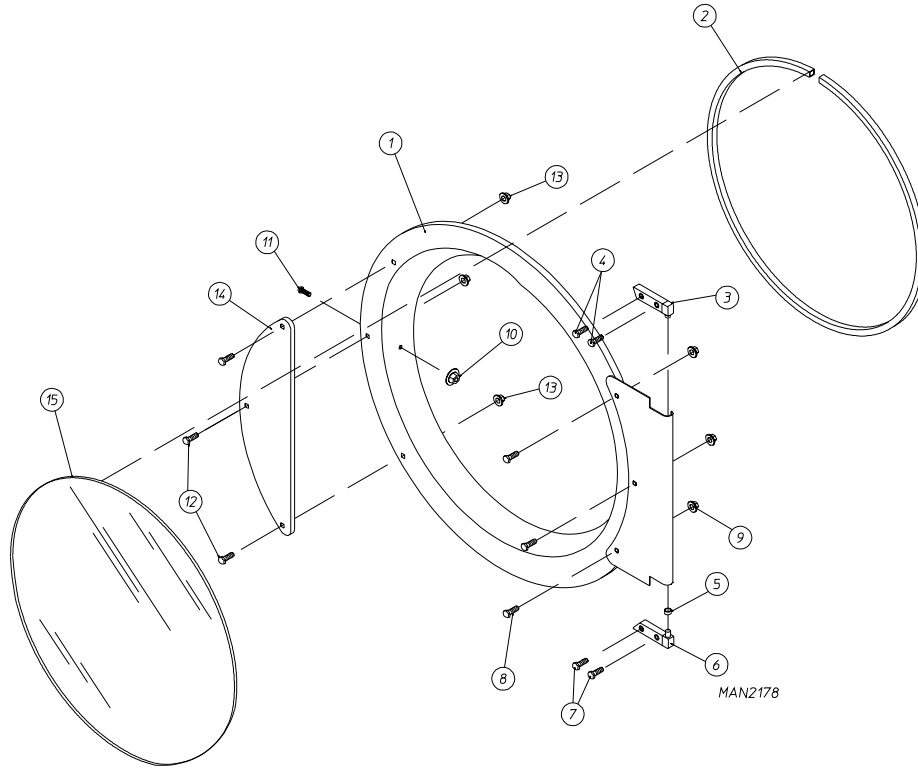

Illus. No.	Part No.	Qty.	Description
1	881150	1	Black Main Door Assembly Complete (includes illus. nos. 1, 2, and 8 through 15)
2	102354	1	Door Gasket
	170730	1	Clear Glass Adhesive (10.3 oz. cartridge)
	170731	1	Black Glass Adhesive (10.3 oz. cartridge)
3	881152	1	Black Top Hinge Block Assembly (includes illus. nos. 3 and 4)
4	150445	2	1/4-20 x 3/4" Black Cap Head Setscrew
5	153031	1	1/4" Nylon Washer
6	881151	1	Black Bottom Hinge Block Assembly (includes illus. nos. 5, 6, and 7)
7	150445	2	1/4-20 x 3/4" Black Cap Head Setscrew
8	150683	3	1/4-20 x 5/8" Black Carriage Bolt
9	152014	3	1/2-20 Free Spin Wash Nut
10	151010	1	#10-32 Black Hex Acorn Nut
11	150120	1	Door Latch Screw
12	150683	3	1/4-20 x 5/8" Black Carriage Bolt
13	152014	3	1/2-20 Free Spin Wash Nut
14	881210	1	Black Main Door Handle ONLY
15	102211	1	20-7/16" Door Glass
	102218	1	20-7/16" Door Glass with 4 Holes (for models mfd. between February 2, 2001 and September 6, 2001)
	170730	1	Clear Glass Adhesive (10.3 oz. cartridge)
	170731	1	Black Glass Adhesive (10.3 oz. cartridge)

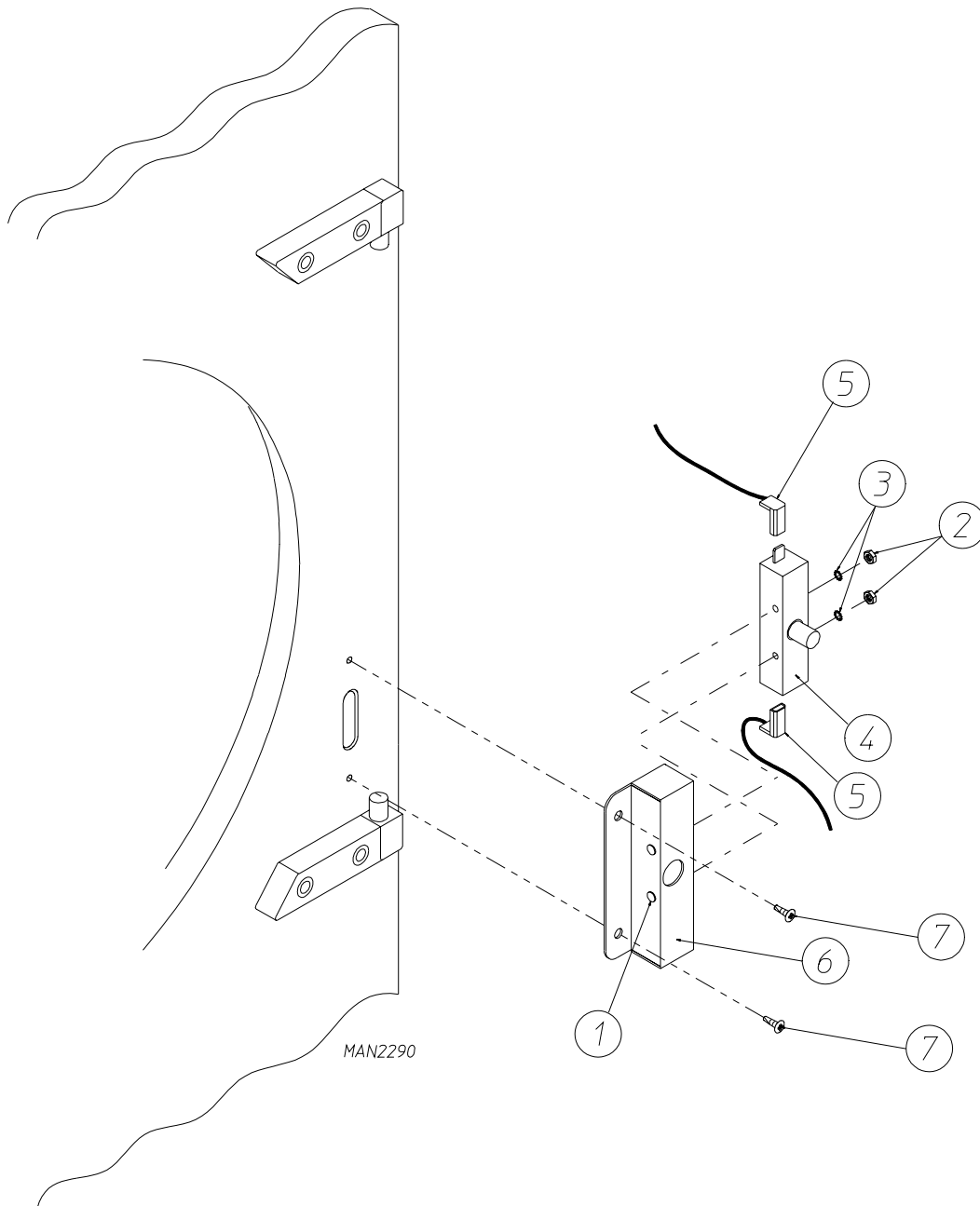

Illus. No.	Part No.	Qty.	Description
1	150006	2	#6-32 x 7/8" Phillips Pan Head Machine Screw
2	152013	2	#6-32 Hex Nut
3	153010	2	#6 Star Washer
4	137005	1	Door Switch
5	122636	2	Flag Terminal
6	881211	1	Black Main Door Switch Housing ONLY
	881153	1	Black Main Door Switch Housing Complete (includes illus. nos. 1, 2, 3, 4, and 6)
7	150301	2	#8-18 x 7/16" Phillips Pan Head TEK Screw

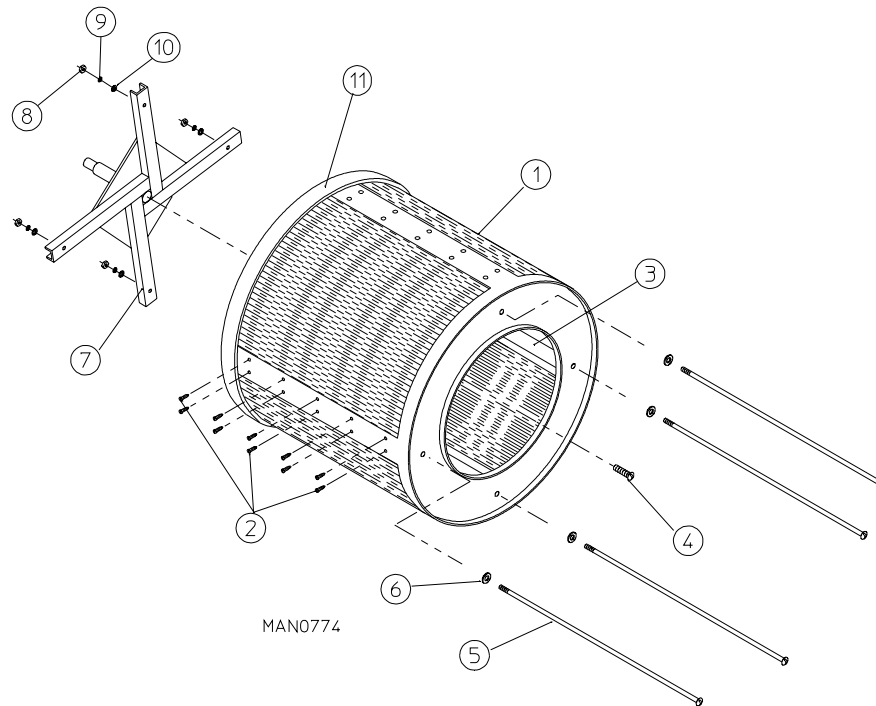

Illus. No.	Part No.	Qty.	Description
1*	882519	1	Galvanized Basket (tumbler) ONLY (without felt collar)
	882520	1	Stainless Steel Basket (tumbler) ONLY (without felt collar)
	882521	1	Polished Stainless Steel Basket (tumbler) ONLY (without felt collar)
	882522	1	Galvanized Basket (tumbler)/Support Assemblies (includes illus. nos. 1 through 10)
	882524		Stainless Steel Basket (tumbler)/Support Assemblies (includes illus. nos. 1 through 10)
	882523		Polished Stainless Steel Basket (tumbler)/Support Assemblies ONLY (without felt collar)
2	150313	40	#10-16 x 1/2" TORX Plus
3	301304	4	Galvanized Basket (tumbler) Rib ONLY
	322002	2	Galvanized Taper Basket (tumbler) Rib
	322003	2	Galvanized Straight Basket (tumbler) Rib
	322001	2	Stainless Steel Straight Basket (tumbler) Rib
	322000	2	Stainless Steel Tapered Basket (tumbler) Rib
	322066	2	Polished Stainless Steel Basket (tumbler) Rib
	322067	2	Polished Stainless Steel Tapered Basket (tumbler) Rib
4	150518	1	5/16-18 x 3/8" Socket Button Head Screw
5	100918	4	3/8-16 x 26 3/4" Tie Rod
6	153004	4	3/8" Flat Washer
7	882517	1	Basket (tumbler) Support ONLY
8	152005	4	3/8-16 Hex Nut
9	153005	4	3/8" Lock Washer
10	153004	4	3/8" Flat Washer
11	116002	1	Felt Collar ONLY
--	401010	1	#847 Adhesive for Felt Collar (5.0 oz. tube)

* Felt collar is not included and **must be** ordered separately.

For Models Mfd. as of September 8, 2000

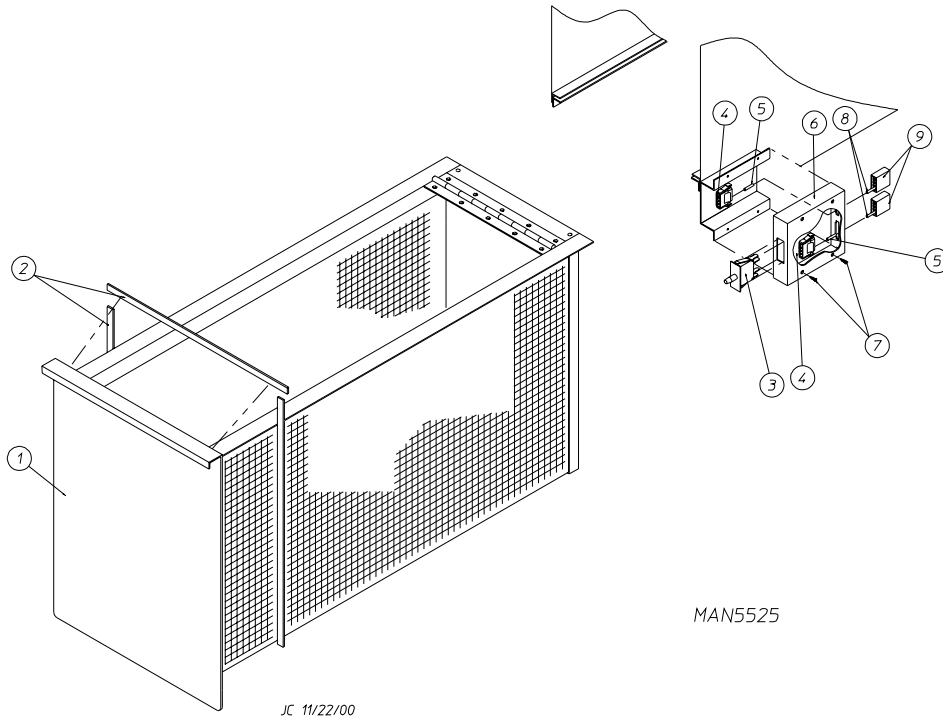

Illus. No.	Part No.	Qty.	Description
1	883155	1	White Lint Drawer Assembly (includes illus. nos. 1 and 2)
	883156	1	Coral Blue Lint Drawer Assembly (includes illus. nos. 1 and 2)
	883157	1	Ivory Lint Drawer Assembly (includes illus. nos. 1 and 2)
2	117605	5	Gasket (sold by the foot)
3	122116	1	Lint Drawer Switch
4	122605	1 or 2	4-Pin Socket Connector ONLY
5	122701	*	Socket Terminal ONLY
	122801	1	Pin/Socket Extraction Tool
6	883229	1	Lint Drawer Switch Box Assembly (includes illus. nos. 4 through 7) (for coin models Only)
	818087	1	Lint Drawer Switch Box Assembly (includes illus. nos. 4 through 7) (for OPL models Only)
	304136	1	Lint Drawer Switch Box ONLY
7	150301	2	#8-18 x 7/16" Phillips Pan Head TEK Screw
8	122700	*	Pin Terminal ONLY
9	122604	1 or 2	4-Pin Connector ONLY

* As required.

For Models Mfd. prior to September 8, 2000

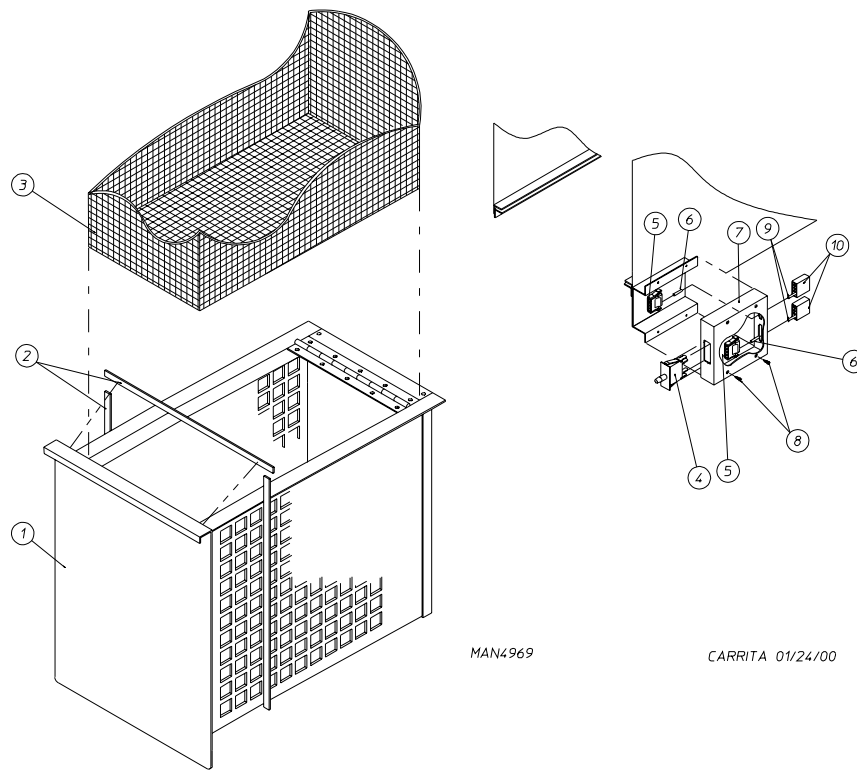

MAN4969

CARRITA 01/24/00

Illus. No.	Part No.	Qty.	Description
1	882514	1	White Lint Drawer Assembly (includes illus. nos. 1 and 2)
	882515	1	Coral Blue Lint Drawer Assembly (includes illus. nos. 1 and 2)
	882516	1	Almond B Lint Drawer Assembly (includes illus. nos. 1 and 2)
2	117605	5	Neoprene Sponge Tape (sold by the foot)
3	108224	1	Lint Screen Assembly
4	122116	1	Lint Drawer Switch
5	122605	1 or 2	4-Pin Socket Connector
6	122701	*	Socket Terminal ONLY
	122801	1	Pin/Socket Extraction Tool
7	883229	1	Lint Drawer Switch Box Assembly (includes illus. nos. 4 through 7) (for coin models Only)
	818087	1	Lint Drawer Switch Box Assembly (includes illus. nos. 4 through 7) (for OPL models Only)
	304136	1	Lint Drawer Switch Box ONLY
8	150301	2	#8-18 x 7/16" Phillips Pan Head TEK Screw
9	122700	*	Pin Terminal ONLY
10	122604	1 or 2	4-Pin Connector ONLY

* As required.

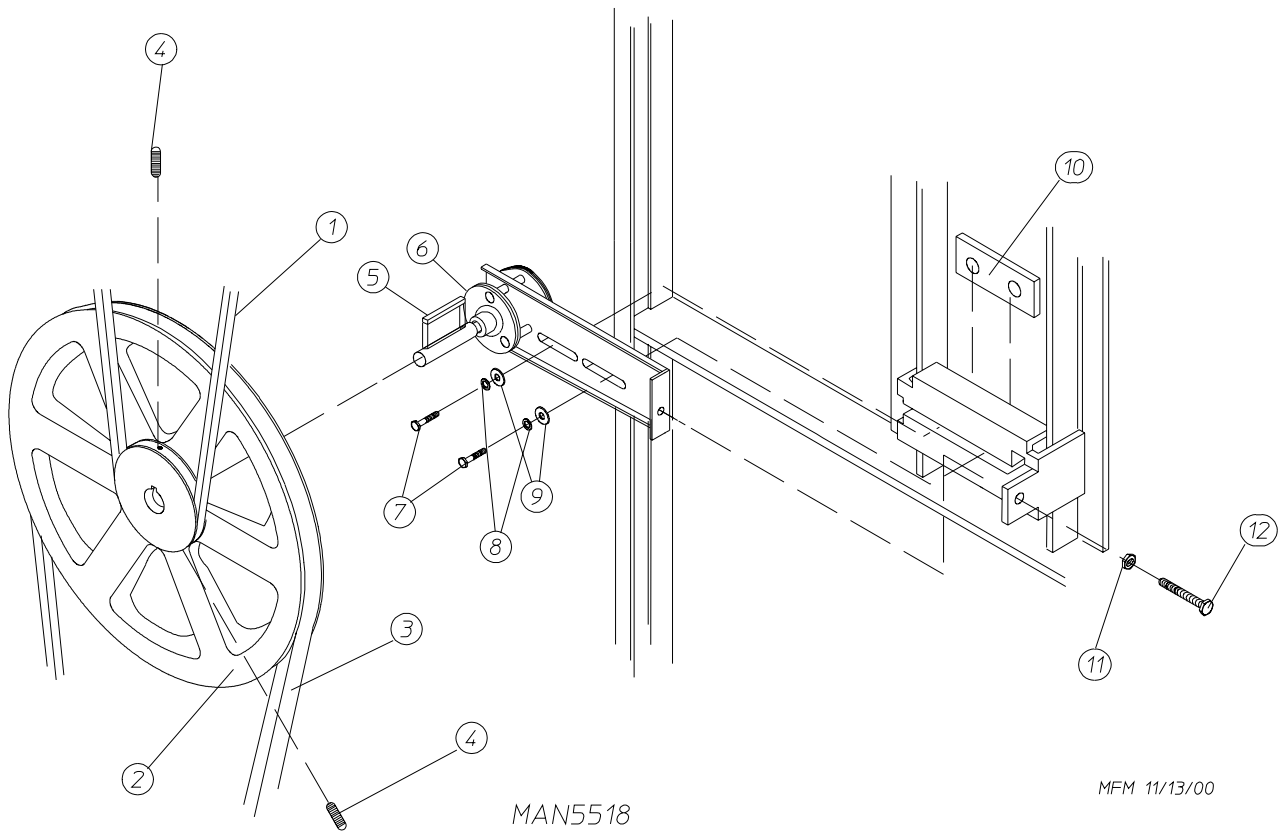

Illus. No.	Part No.	Qty.	Description
1	100100	1	5L-660 V-Belt (basket [tumbler] to idler) - Non-Reversing Models ONLY
	100108	1	5L-680 V-Belt (basket [tumbler] to idler) - Reversing Models ONLY
2	101129	1	9" x 2-1/2" Compound Pulley
3	100105	1	4L-520 V-Belt (idler to motor) - Non-Reversing Models ONLY
	100112	1	4L-610 V-Belt (idler to motor) - Reversing Models ONLY
4	154301	2	5/16-18 x 1" Allen Setscrew
5	100705	1	3/16" x 3/16" x 1-3/8" Key
6	882576	1	Idler Bearing Assembly Complete (includes illus. nos. 5 through 12)
7	150617	2	3/8-16 x 1" Hex Head Machine Bolt
8	153005	2	3/8" Lock Washer
9	153004	2	3/8" Flat Washer
10	801009	1	Idler Square Washer
11	152004	1	5/16-18 Hex Nut
12	150509	1	5/16-18 x 3" Hex Head Machine Bolt

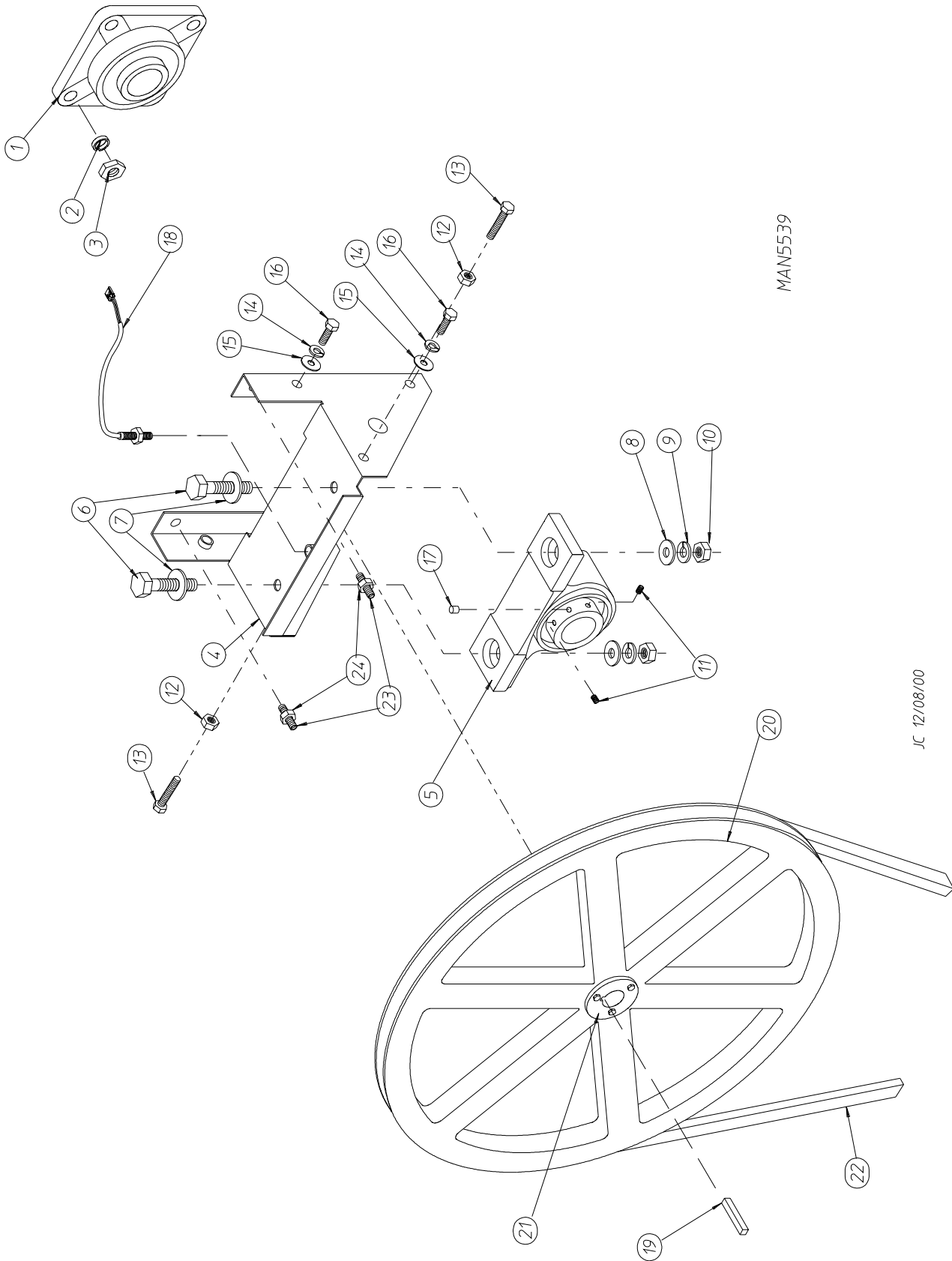

For Models Mfd. as of July 17, 2000

Illus. No.	Part No.	Qty.	Description
1	880220	1	1-3/4" Flange Bearing
2	153025	4	9/16" Lock Washer
3	152050	4	9/16-12 Hex Nut
4	882544	1	Pillow Block Bearing Assembly Complete (includes illus. nos. 4 through 17, 23, and 24)
	882545	1	Pillow Block Bearing Assembly Complete with Rotational Sensor (includes illus. nos. 4 through 18, 23, and 24)
	882542	1	Pillow Block Bearing Platform ONLY
	882543	1	Pillow Block Bearing Platform ONLY (for models with rotational sensor)
5	880202	1	1-3/8" Pillow Block Bearing
	880779	1	1-3/8" Pillow Block Bearing (for reversing models Only)
6	150601	2	3/8-16 x 2" Hex Bolt
7	153004	2	3/8" Flat Washer
8	153004	2	3/8" Flat Washer
9	153005	2	3/8" Lock Washer
10	152005	2	3/8-16 Hex Nut
11	154326	2	5/16-24 x 3/8" Setscrew
12	152004	2	5/16-18 Hex Nut
13	150621	2	5/16-18 x 1-1/2" Tap Bolt
14	153002	4	5/16" Lock Washer
15	153004	6	3/8" Flat Washer
16	150501	4	5/16-18 x 3/4" Tap Bolt
17	102120	1	Sintered 8 Magnet (for reversing models Only)
18	824807	1	Rotational Sensor Assembly
19	100724	1	Shaft Key (for non-reversing models mfd. as of July 9, 2001)
	100713	1	Shaft Key (for non-reversing models mfd. prior to July 9, 2001)
	100735	1	Shaft Key (for reversing models Only)
20	101100	1	18" Pulley (for non-reversing models Only)
	101118	1	18-3/4" Pulley (for reversing models Only)
21	101110	1	1" Taper Lock Bushing (for reversing models Only)
22	100100	1	5L-660 V-Belt (basket [tumbler] to idler) (for non-reversing models Only)
	100108	1	5L-680 V-Belt (basket [tumbler] to idler) (for reversing models Only)
23	150610	2	5/16-18 x 1-1/2 Allen Setscrew
24	152004	2	5/16-18 Hex Nut

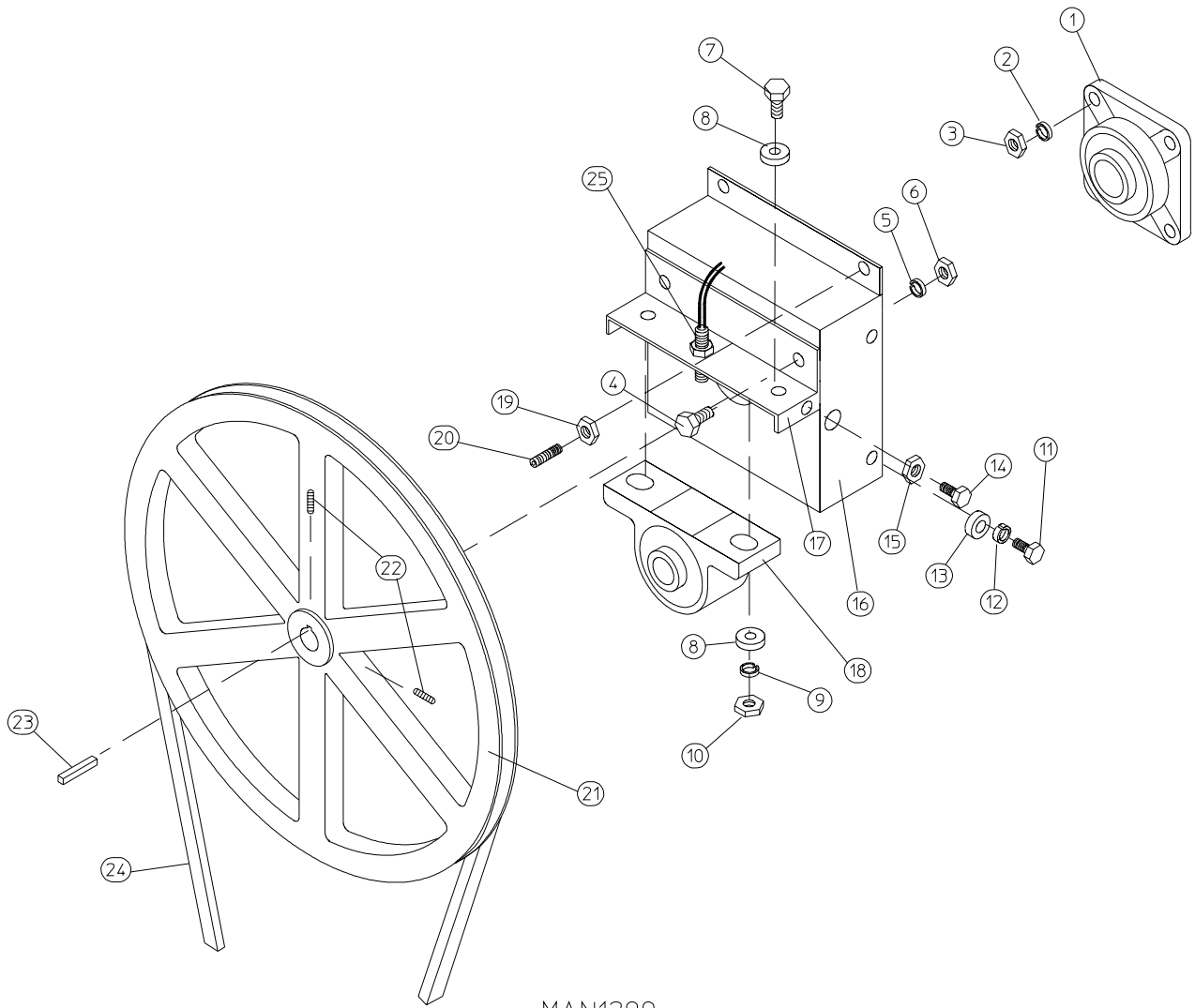

MAN1299

For Models Mfd. prior to July 17, 2000

Illus. No.	Part No.	Qty.	Description
1	880220	1	1-3/4" Flange Bearing with Nylock Setscrew
2	153025	4	9/16" Lock Washer
3	152050	4	9/16-12 Hex Nut
4	150508	2	3/8-16 x 3/4" Hex Head Machine Bolt
5	153005	2	3/8" Lock Washer
6	152005	2	3/8-16 Hex Nut
7	150600	2	3/8-16 x 1-1/2" Hex Head Machine Bolt
8	153004	*	3/8" Flat Washer
9	153005	2	3/8" Lock Washer
10	152005	2	3/8-16 Hex Nut
11	150501	4	5/16-18 x 3/4" Hex Head Machine Bolt
12	153002	4	5/16" Lock Washer
13	153001	4	5/16" Flat Washer
14	150621	2	5/16-18 x 1-1/2" Hex Head Machine Bolt
15	152004	2	5/16-18 Hex Nut
16	801101	1	1-3/8" Bearing Box Assembly Complete (includes illus. nos. 4 through 20) (for models mfd. without rotational sensor)
	801103	1	1-3/8" Bearing Box and Support ONLY (includes illus. nos. 4, 5, 6, 16, and 17)
	801105	1	1-3/8" Bearing Box ONLY
17	801104	1	Pillow Block Bearing Support ONLY
18	880779	1	1-3/8" Pillow Block Bearing Assembly with Magnet (for models mfd. with rotational sensor)
	880202	1	1-3/8" Pillow Block Bearing with Nylock Setscrew
19	152004	2	5/16-18 Hex Nut
20	150610	2	5/16-18 x 1-1/2" Allen Setscrew
21	101100	1	18" Pulley (for non-reversing models Only)
	101118	1	18-3/4" Pulley (for reversing models Only)
	101110	1	1" Taper Lock Hub (key not included) (for reversing models Only)
	100735	1	Shaft Key (for taper lock hub)
22	154301	2	5/16-18 x 1" Allen Setscrew
23	100713	1	1/4" x 1/4" x 7/8" Key
24	100100	1	5L-660 V-Belt (basket [tumbler] to idler) (for non-reversing models Only)
	100108	1	5L-680 V-Belt (basket [tumbler] to idler) (for reversing models Only)
25	824807	1	Rotational Sensor Assembly

* As required.

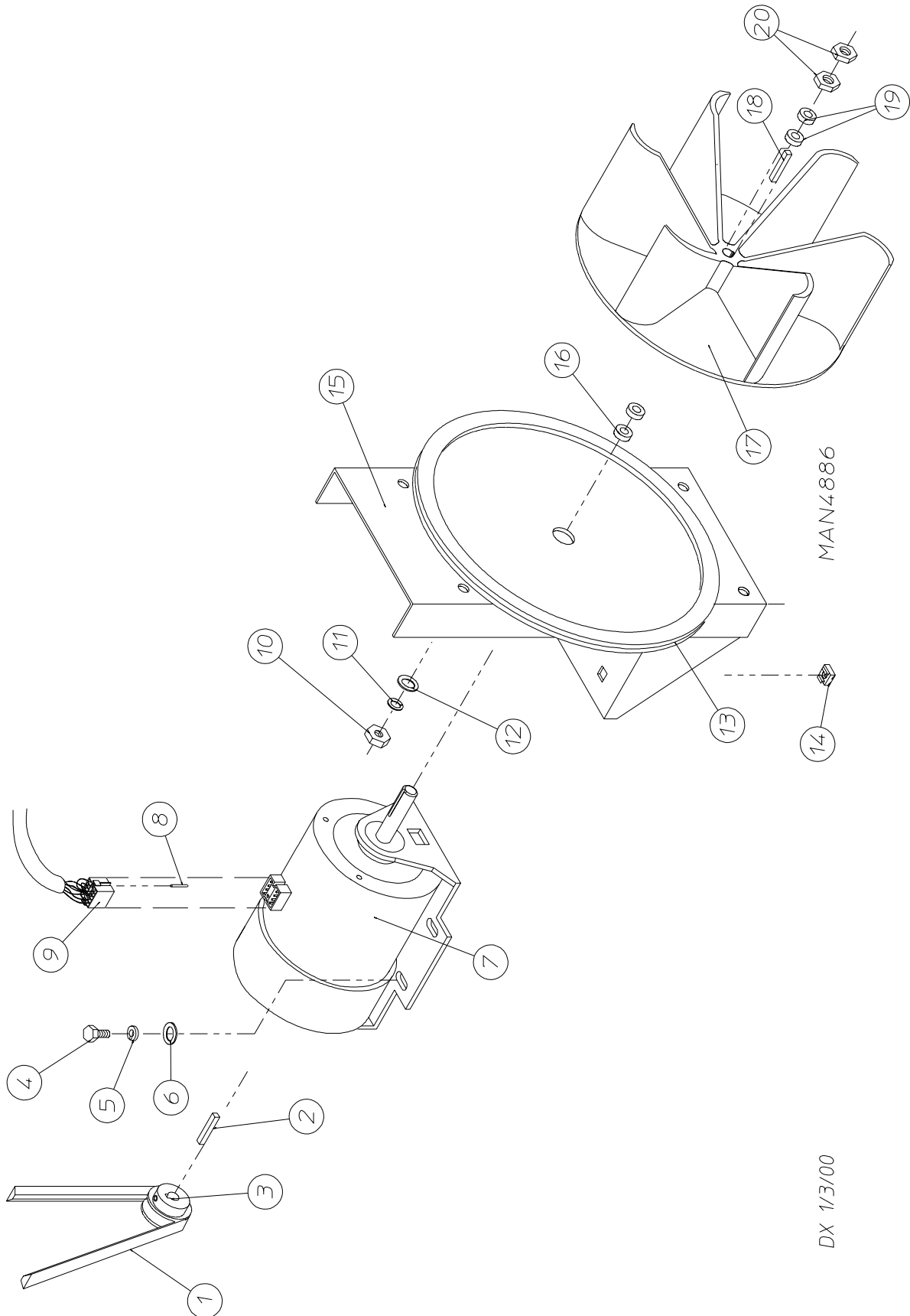

Illus. No.	Part No.	Qty.	Description
1	100105	1	4L-520 V-Belt (to idler motor)
2	100701	1	3/16" x 3/16" x 1" Key (for use on 3Ø - 60 Hz Only)
3	101104	1	1/2" x 2" Motor Pulley (for use on 1Ø - 60 Hz Only)
	101132	1	5/8" x 2" Motor Pulley (for use on 3Ø - 60 Hz Only)
	101133	1	5/8" x 2-1/4" Motor Pulley (for use on 50 Hz Only)
4	150501	4	5/16-18 x 3/4" Hex Head Machine Bolt
5	153002	4	5/16" Lock Washer
6	153001	4	5/16" Flat Washer
7	100065	1	1/2 HP 120-230v 1Ø 60 Hz 100v-50 Hz Totally Enclosed, Fan-Cooled (T.E.F.C.) Motor with Plug
	100066	1	1/2 HP 240v 1Ø 50 Hz Totally Enclosed, Fan-Cooled (T.E.F.C.) Motor with Plug
8	122701	8	Socket Terminal ONLY
	122801	1	Pin/Socket Extraction Tool
9	137030	1	8-Pin Housing Connector
10	152004	4	5/16-18 Hex Nut
11	153002	4	5/16" Lock Washer
12	153001	4	5/16" Flat Washer
13	117600	4	Noise Suppressor Tape (sold by the foot)
14	154000	4	5/16-18 Tinnerman Nut
15	800908	1	Non-Reversing Motor Mount ONLY (56Z frame)
	803938*	1	1/2 HP 120-230v 1Ø 50/60 Hz Totally Enclosed, Fan-Cooled (T.E.F.C.) Motor Mount Assembly Complete with Plug Motor (includes illus. nos. 3 through 7 and 13 through 20)
	803813	1	1/2 HP 240v 1Ø 50 Hz Non-Reversing Totally Enclosed, Fan-Cooled (T.E.F.C.) Motor Mount Assembly Complete with Plug Motor (includes illus. nos. 3 through 7 and 13 through 20)
	803809*	1	1/2 HP 208/230/380/460v 3Ø 60 Hz Totally Enclosed, Fan-Cooled (T.E.F.C.) Motor Mount Assembly Complete (includes illus. nos. 2 through 6 and 13 through 20)
	803810*	1	1/2 HP 208/230/380/460v 3Ø 50 Hz Non-Reversing Totally Enclosed, Fan-Cooled (T.E.F.C.) Motor Mount Assembly Complete (includes illus. nos. 2 through 6 and 13 through 20)
16	153050	2	1/2" S.A.E. Flat Washer
17	100604	1	12-1/2" Impellor with 1/2" Bore
18	100702	1	1/8" x 1/8" x 1-1/2" Key
19	153050	2	1/2" S.A.E. Flat Washer
20	152006	2	1/2-20 Left Hand Jam Nut

* Specify voltage when ordering.

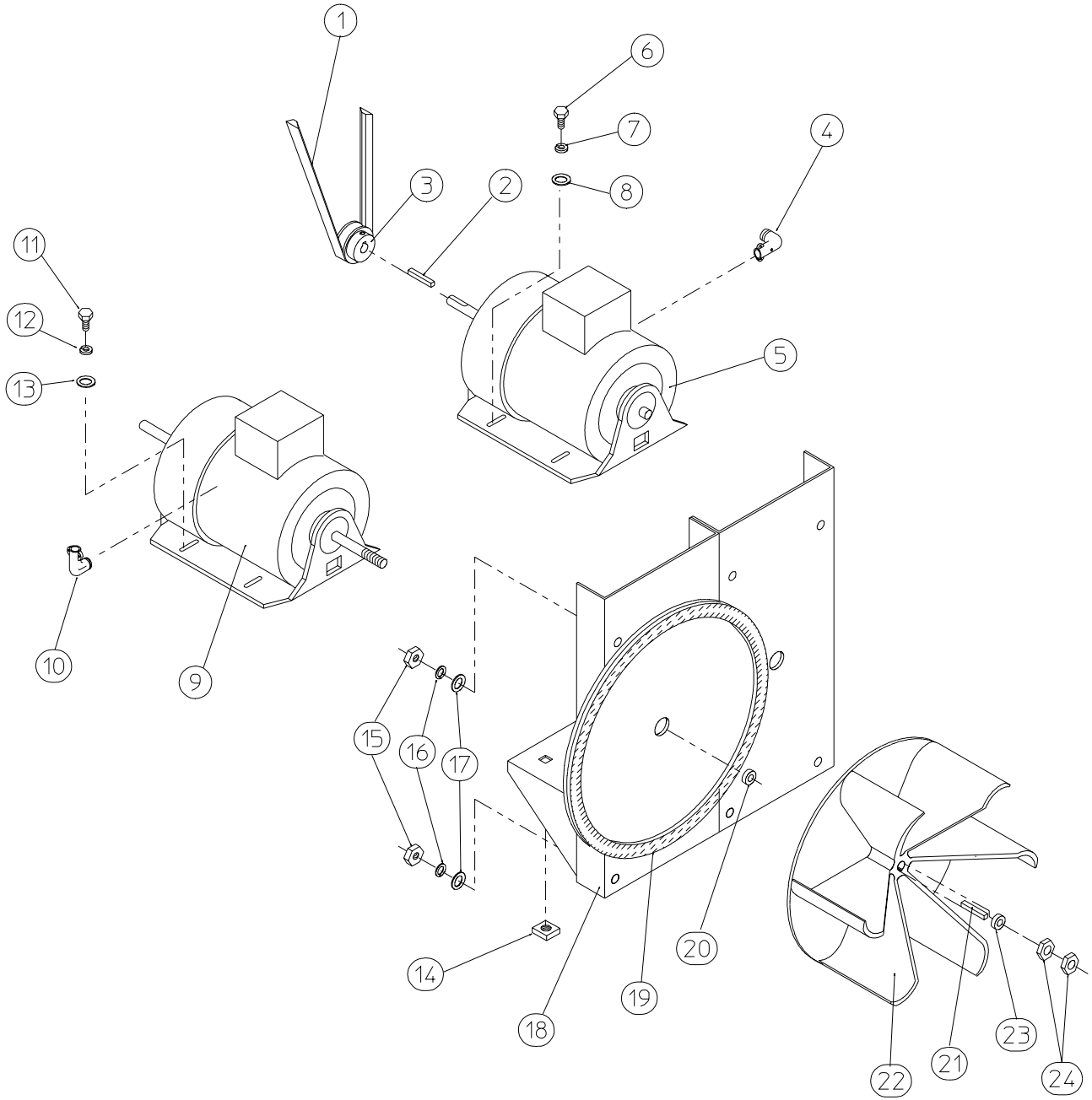

MAN1970

Illus. No.	Part No.	Qty.	Description
1	100112	1	4L-610 V-Belt (to idler motor)
2	100701	1	3/16" x 3/16" x 1" Key
3	101132	1	5/8" x 2" Motor Pulley (for 60 Hz models Only)
	101133	1	5/8" x 2-1/4" Motor Pulley (for 50 Hz models Only)
4	120200	1	3/8" x 90° Connector
5*	181003	1	1/2 HP 208/230/380/460v 3ø 50/60 Hz Motor (56 Hz frame)
6	150501	4	5/16-18 x 3/4" Hex Head Machine Bolt
7	153002	4	5/16" Lock Washer
8	153001	4	5/16" Flat Washer
9*	100007	1	1/2 HP 208/230/380/460v 3ø 50/60 Hz Totally Enclosed, Fan-Cooled (T.E.F.C.) Motor (56 Hz frame)
10	120200	1	3/8" x 90° Connector
11	150501	4	5/16-18 x 3/4" Hex Head Machine Bolt
12	153002	4	5/16" Lock Washer
13	153001	4	5/16" Flat Washer
14	154000	8	5/16" Tinnerman Nut
15	152004	4	5/16" Hex Nut
16	153002	4	5/16" Lock Washer
17	153001	4	5/16" Flat Washer
18	850070	1	Reversing Motor Mount ONLY (56Z frame) (includes illus. nos. 18 and 19)
	803802*	1	Reversing Totally Enclosed, Fan-Cooled (T.E.F.C.) Motor Mount Assembly Complete For 60 Hz Models ONLY (includes illus. nos. 2 through 14 and 18 through 24)
	803803*	1	Reversing Totally Enclosed, Fan-Cooled (T.E.F.C.) Motor Mount Assembly Complete For 50 Hz Models ONLY (includes illus. nos. 2 through 14 and 18 through 24)
19	117604	4	Neoprene Sponge Tape (sold by the foot)
20	153050	2	1/2" S.A.E. Flat Washer
21	100702	1	1/8" x 1/8" x 1-1/2" Key
22	100604	1	12-1/2" Impellor with 1/2" Bore
23	153050	2	1/2" S.A.E. Flat Washer
24	152006	2	1/2-20 Left Hand Jam Nut

* Specify voltage when ordering.

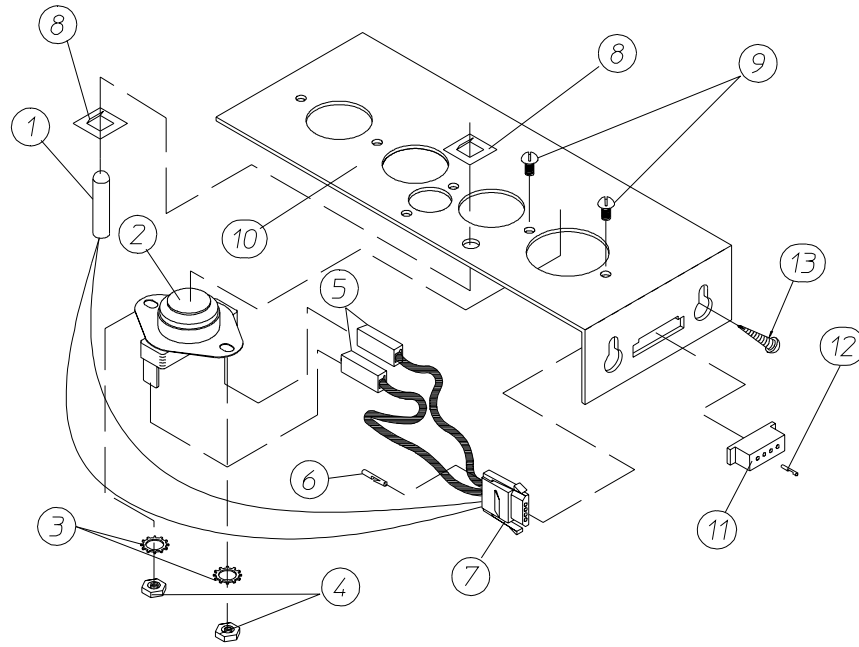

MICROPROCESSOR SENSOR BRACKET ASSEMBLY

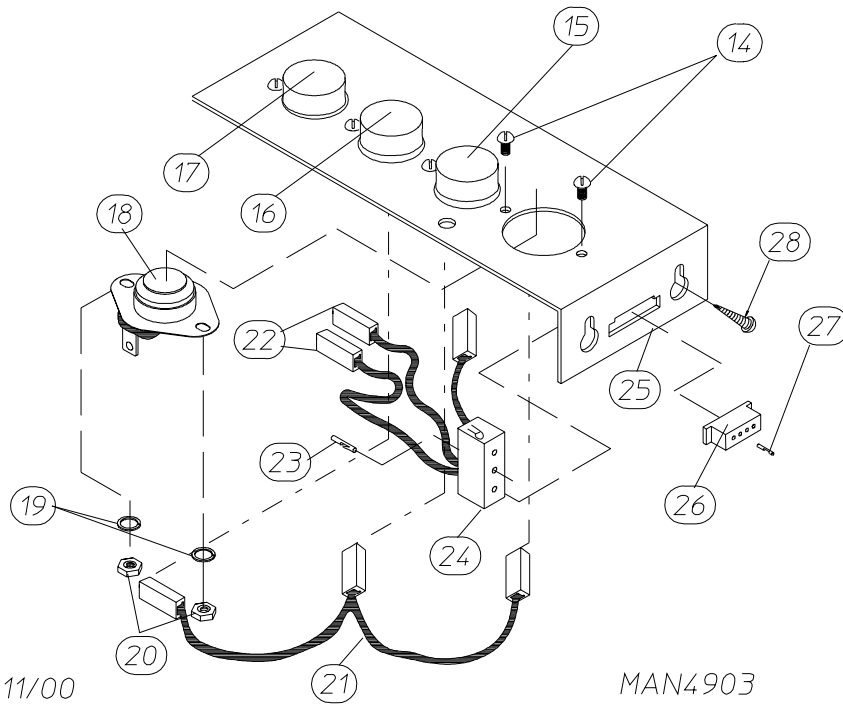

DX 01/11/00

MAN4903

NON-COMPUTER SENSOR BRACKET ASSEMBLY

Illus. No.	Part No.	Qty.	Description
1	880251	1	1/4" Temperature Sensor Probe Assembly (includes illus. nos. 1 and 5 through 8)
2	130301	1	225° Manual Reset Thermostat
3	153010	2	#6 Star Washer
4	152000	2	#6-32 Hex Nut
5	121028	2	Insulated Female Terminal
6	122701	4	Socket Terminal ONLY
	112801	1	Pin/Socket Extraction Tool
7	122605	1	4-Pin Socket Connector ONLY
8	154007	2	1/4" Tinnerman Push On Fastener
9	150005	2	#6-32 x 1/4" Phillips Round Head Machine Screw
10	824051	1	Microprocessor Sensor Bracket Assembly Complete (includes illus. nos. 1 through 10)
	322062	1	Universal Sensor Bracket ONLY
11	122604	1	4-Pin Connector ONLY
12	122700	4	Pin Terminal ONLY
13	150301	2	#8-18 x 7/16" Phillips Pan Head TEK Screw
14	150005	5	#6-32 x 1/4" Phillips Round Head Machine Screw
15	130111	1	130° Large Thermostat
16	130100	1	150° Large Thermostat
17	130301	1	225° Manual Reset Thermostat
18	130101	1	180° Large Thermostat
19	153010	5	#6 Star Washer
20	152000	5	#6-32 Hex Nut
21	882535	1	Sensor Jumper ONLY
22	121028	4	Insulated Female Terminal
23	122701	4	Socket Terminal ONLY
24	122605	1	4-Pin Socket Connector ONLY
	882534	1	Sensor Bracket Harness Assembly (includes illus. nos. 22, 23, and 24)
25	882536	1	Non-Computer Sensor Bracket Assembly Complete (includes thermostats) (includes illus. nos. 14 through 25)
	322062	1	Universal Sensor Bracket ONLY
26	122604	1	4-Pin Connector ONLY
27	122700	4	Pin Terminal ONLY
	122801	1	Pin/Socket Extraction Tool
28	150301	2	#8-18 x 7/16" Phillips Pan Head TEK Screw

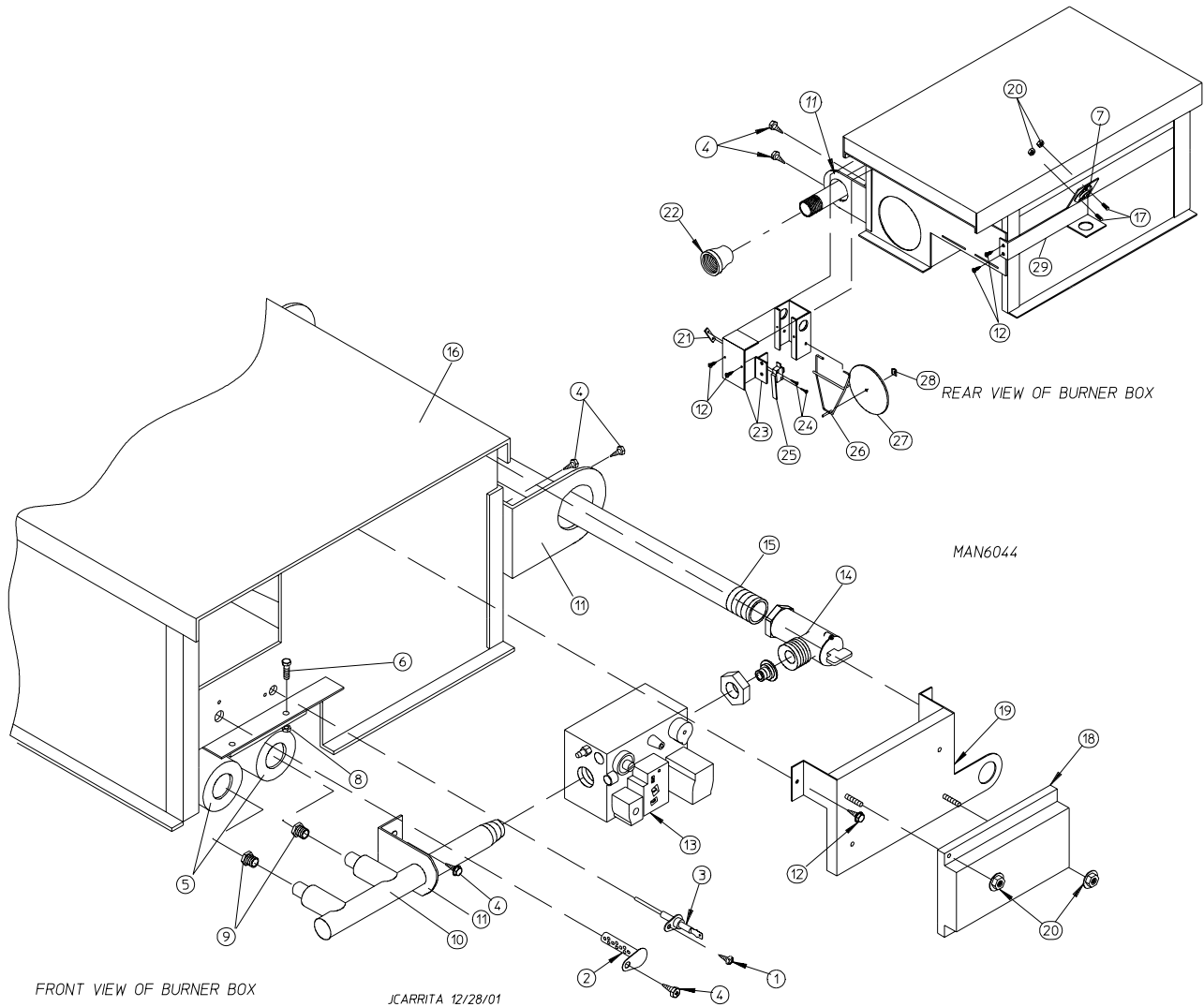

Illus. No.	Part No.	Qty.	Description
1	150301	1	#8-18 x 7/16" Phillips Pan Head TEK Screw
2	128920	1	Hot Surface Ignitor 24V 2-1/2" Long
3	128921	1	Hot Surface Ignition (HSI) Flame Sensor
4	150309	7	#10-16 x 1/2" Hex Head TEK Crimptite Screw
5	141105	2	Large Tube Burner
6	150108	2	#8-32 x 1/2" Pan Head Machine Screw
7	130201	1	330° Hi-Limit with Manual Reset
8	151001	2	#8-32 Pal Nut
9	140820*	2	#29 Orifice (natural gas)
	140804*	2	#48 Orifice (liquid propane [L.P.] gas)
10	141230	1	1/2" Direct Spark Ignition (DSI) Manifold (2-port)
11	318700	3	Pipe Bracket (bent)
12	150300	7	#10-16 x 1/2" Hex Washer TEK Screw
13	128933	1	CE Gas Valve
	883255	1	CE 1/2" Liquid Propane (L.P.) Gas Valve
14	141314	1	90° x 1/2" x 1-1/2" Gas Shutoff Assembly
15	142809	1	1/2" x 29-1/8" Pipe
16	850896	1	Hot Surface Ignition (HSI) Burner Box ONLY
	817066**	1	Hot Surface Ignition (HSI) Burner Assembly (natural gas)
	817067**	1	Hot Surface Ignition (HSI) Burner Assembly (liquid propane [L.P.] gas)
	882390*	1	Euro-14 Liquid Propane (L.P.) Conversion Kit
	880603***	1	Steam to Gas Interface Plate
17	150001	2	Round Head Machine Screw
18	128975	1	CE Hot Surface Ignition (HSI) Module
19	810029	1	Hot Surface Ignition (HSI) Module Mounting Bracket Assembly (for models mfd. as of January 11, 2002)
	817091	1	Hot Surface Ignition (HSI) Module Mounting Bracket Assembly (for models mfd. prior to January 11, 2002)
20	151000	4	#6-32 Pal Nut
21	154004	1	Twin Speed Nut
22	142935	1	1/2" BSPT x 1/2" N.P.T. Transition Coupling
23	802799	1	Sail Switch Top and Switch Bracket
24	150303	2	#4 x 3/4" Pan Head "A" Machine Screw
25	122200	1	SPST Sail Switch
26	105500	1	Sail Switch Actuator Rod
27	319202	1	Sail Switch Damper (flat)
28	154002	1	1/8" Push On Fastener
29	319704	1	Hi-Limit Mounting Bracket

* Consult factory for elevations over 2,000 feet.

** Burner orifices *are not included* and **must be** ordered separately.

*** Needed when converting steam heat to gas heat.

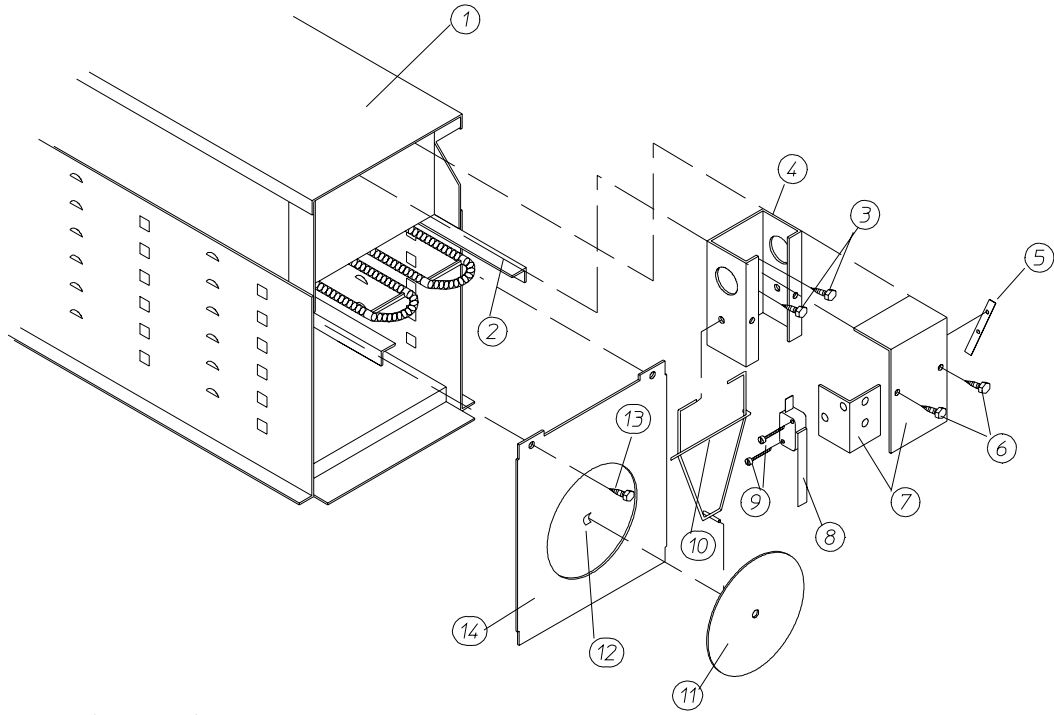

ELECTRIC OVEN (FRONT VIEW)

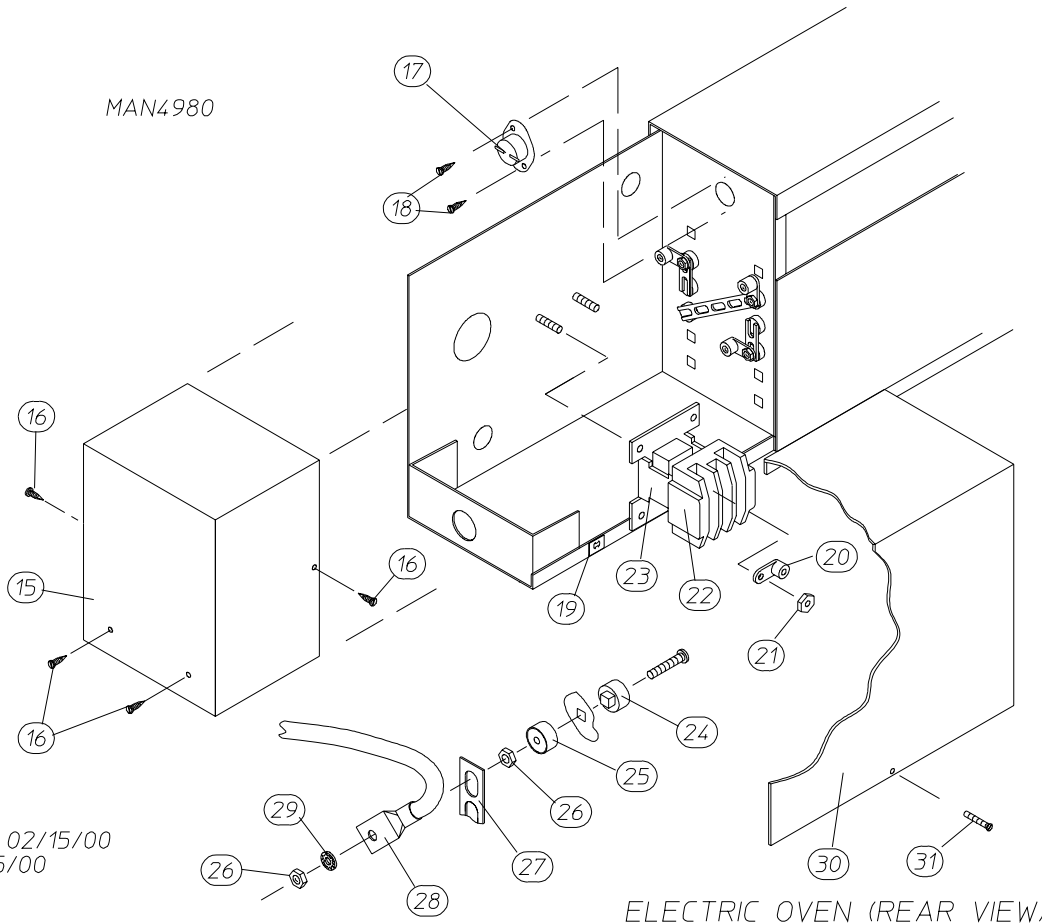

Illus. No.	Part No.	Qty.	Description
1*	803007	1	Large Electric Oven Box ONLY
	-----	1	Electric Oven Assembly Complete
2*	-----	-	Electric Element
3	150300	2	#10-16 x 1/2" Hex Washer TEK Screw
4	802800	1	Sail Switch Box with Bracket and Cover ONLY
	802801	1	Sail Switch Box Assembly Complete (includes illus. nos. 4 through 12)
5	154004	1	Twin Speed Nut
6	150300	2	#10-16 x 1/2" Hex Washer TEK Screw
7	802799	1	Sail Switch Box Cover and Bracket ONLY
8	122200	1	Sail Switch ONLY
9	150303	2	#4 x 3/4" Pan Head "A" Machine Screw
10	105500	1	Sail Switch Actuator Rod
11	319202	1	Sail Switch Damper (flat)
12	154002	1	1/8" Push On Fastener
13	150300	2	#10-16 x 1/2" Hex Washer TEK Screw
14	803100	1	Electric Oven Front Cover ONLY
15	320611	1	Large Relay Box Cover ONLY
16	150301	3	#8-18 x 7/16 Phillips Pan Head TEK Screw
17	130400	1	290° Hi-Limit Thermostat
18	150300	2	#10-16 x 1/2" Hex Washer TEK Screw
19	154001	1	#10-24 Speed Nut
20	121010	1	L-70 Ground Lug
21	152014	3	1/4-20 Free Spin Wash Nut
22	-----*	1	Oven Relay
23	-----*	1	Oven Relay Replacement Coil
24	120081	-	Internal Ceramic Insulator (2 per element)
25	120080	-	External Ceramic Insulator (2 per element)
26	152008	-	#10-32 Hex Nut (4 per element)
27	121011	-	Bus Bar (sold by the foot)
28	-----*	-	Oven Wire with Crimp Lug
29	153009	-	#10 Star Washer (2 per element)
30	321301	1	Large Electric Oven Right Side Cover ONLY
31	150402	1	#10-24 x 5/8" Truss Head Machine Screw
--	882603**	1	Steam to Electric Transition Plate

* Refer to **Electrical Oven Component Application Chart** on page 40.

** Not illustrated...needed to convert dryer from steam to electric.

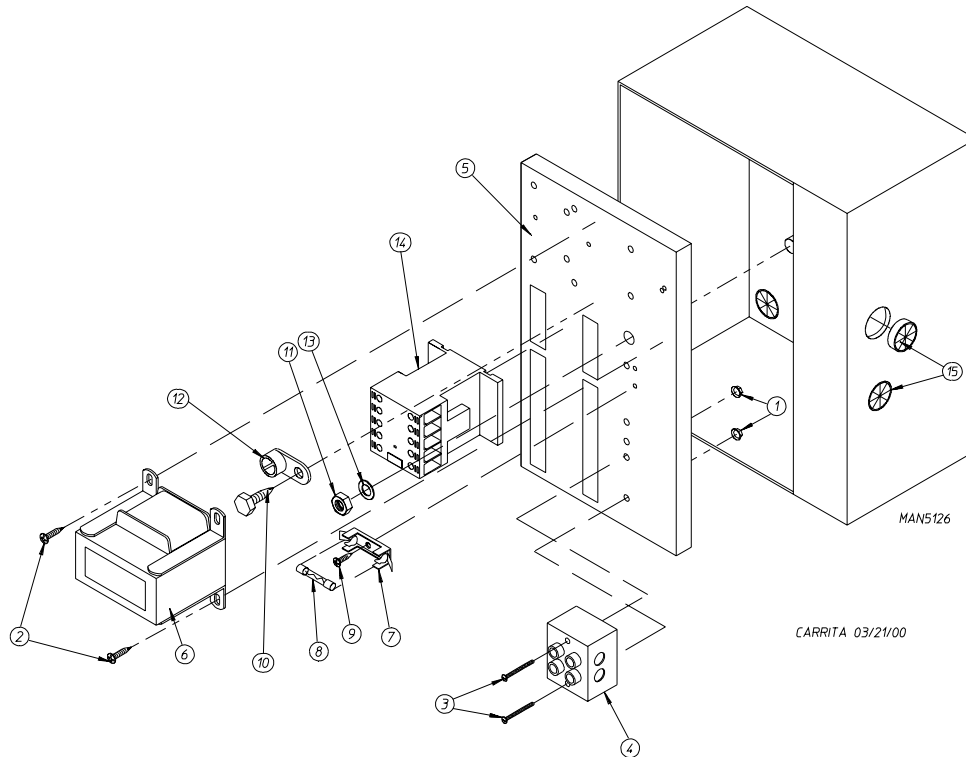

Illus. No.	Part No.	Qty.	Description
1	151000	2	#6-32 Pal Nut
2	150300	2	#10-16 x 1/2" Hex Washer TEK Screw
3	150008	2	#6-32 x 1-1/4" Phillips Pan Head Machine Screw
4	120716	1	2-Position Terminal Block
5	322817	1	Rear Electric Mounting Plate ONLY
	818073	1	Rear Electric Panel Assembly Complete - 120 Volt (includes illus. nos. 1 through 14)
	818044	1	Rear Electric Panel Wiring (120 Volt Only)...Not Illustrated
	-----*	1	Rear Electric Panel Assembly Complete - 208-240 Volt (includes illus. nos. 1 through 14)
	-----*	1	Rear Electric Panel Wiring (208-240 Volt Only)...Not Illustrated
6	818075	1	Transformer Assembly - 120 Volt
	-----*	1	Transformer Assembly - 208-240 Volt
7	136008	1 or 2	Fuse Holder ONLY
8	136049	1	3/4-Amp (slo blo) Fuse ONLY - 120 Volt
	136057	2	1/2-Amp (slo blo) Fuse ONLY - 208-240 Volt
9	150301	1	#8-18 x 7/16" Phillips Pan Head TEK Screw
10	150297	1	#10 x 1/2" Hex Washer TEK Screw (green)
11	152004	1	5/16-18 Hex Nut
12	121010	1	L-70 Ground Lug
13	153002	1	5/16" Lock Washer
14	132459	1	3-Pole Contactor
15	121300	3	Open/Closed Bushing

* Not available at time of printing (contact factory for further information).

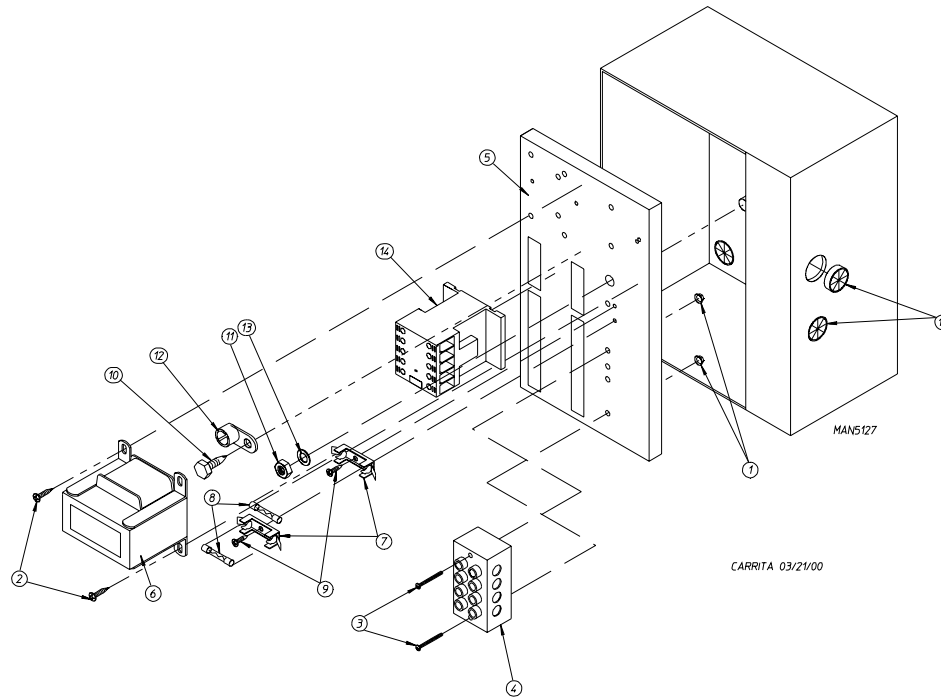

Illus. No.	Part No.	Qty.	Description
1	151000	2	#6-32 Pal Nut
2	150300	2	#10-16 x 1/2" Hex Washer TEK Screw
3	150008	2	#6-32 x 1-1/4" Phillips Pan Head Machine Screw
4	120716	1	2-Position Terminal Block
5	322817	1	Rear Electric Mounting Plate ONLY
	818074	1	Rear Electric Panel Assembly Complete - 208-240 Volt (includes illus. nos. 1 through 14)
	818072	1	Rear Electric Panel Wiring 208-240 Volt...Not Illustrated
	818069	1	Rear Electric Panel Assembly 380-416 Volt 3 ϕ (includes illus. nos. 1 through 14)
	818070	1	Rear Electric Panel Wiring 380-416 Volt 3 ϕ ...Not Illustrated
	-----*	1	Rear Electric Panel Assembly 380-416 Volt 3 ϕ w 1 ϕ Motor (includes illus. nos. 1 through 14)
	-----*	1	Rear Electric Panel 380-416 Volt 3 ϕ w 1 ϕ Motor...Not Illustrated
6	818036	1	Transformer Assembly - 208-240 Volt
	818037	1	Transformer Assembly - 380-416 Volt
7	136008	2	Fuse Holder ONLY
8	136057	2	1/2-Amp (slo blo) Fuse ONLY
9	150301	2	#8-18 x 7/16" Phillips Pan Head TEK Screw
10	150297	1	#10 x 1/2" Hex Washer TEK Screw (green)
11	152004	1	5/16-18 Hex Nut
12	121010	1	L-70 Ground Lug
13	153002	1	5/16" Lock Washer
14	132459	1	3-Pole Contactor
15	121300	3	Open/Closed Bushing

* Not available at time of printing (contact factory for further information).

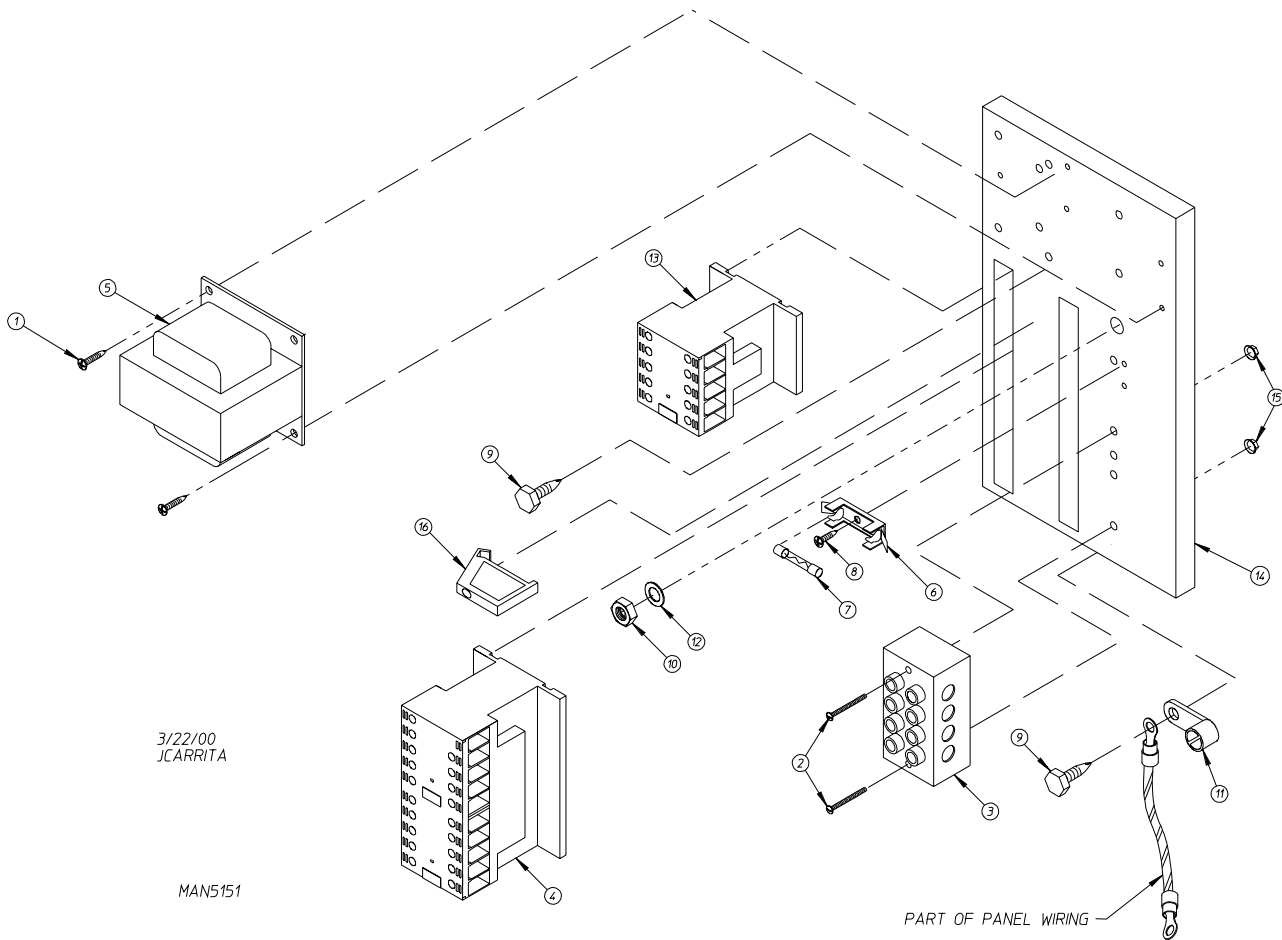

Illus. No.	Part No.	Qty.	Description
1	150300	2	#10-16 x 1/2" Hex Washer TEK Screw
2	150008	2	#6-32 x 1-1/4" Phillips Pan Head Machine Screw
3	120701	1	4-Position Terminal Block
4	132458	1	3-Pole Reversing Contactor
5	818036	1	Transformer Assembly - 208-240 Volt
	818037	1	Transformer Assembly - 380-416 Volt
6	136008	1	Fuse Holder ONLY
7	136057	1	1/2-Amp (slo blo) Fuse ONLY - 208-240 Volt
8	150301	1	#8-18 x 7/16" Phillips Pan Head TEK Screw
9	150297	1	#10 x 1/2" Hex Washer TEK Screw (green)
10	152004	1	5/16-18 Hex Nut
11	121010	1	L-70 Ground Lug
12	153002	1	5/16" Lock Washer
13	132459	1	3-Pole Contactor
14	322812	1	Rear Electric Mounting Plate ONLY
	-----*	1	Rear Electric Panel Assembly Complete - 208-240 Volt (includes illus. nos. 1 through 14)
	-----*	1	Rear Electric Panel Wiring 208-240 Volt...Not Illustrated
	819068	1	Rear Electric Panel Assembly Complete 380-416 Volt
	819044	1	Rear Electric Panel Wiring (380-416 Volt Only)...Not Illustrated
15	151000	2	#6-32 Pal Nut
16	120765	1	Standard End Bracket

* Not available at time of printing (contact factory for further information).

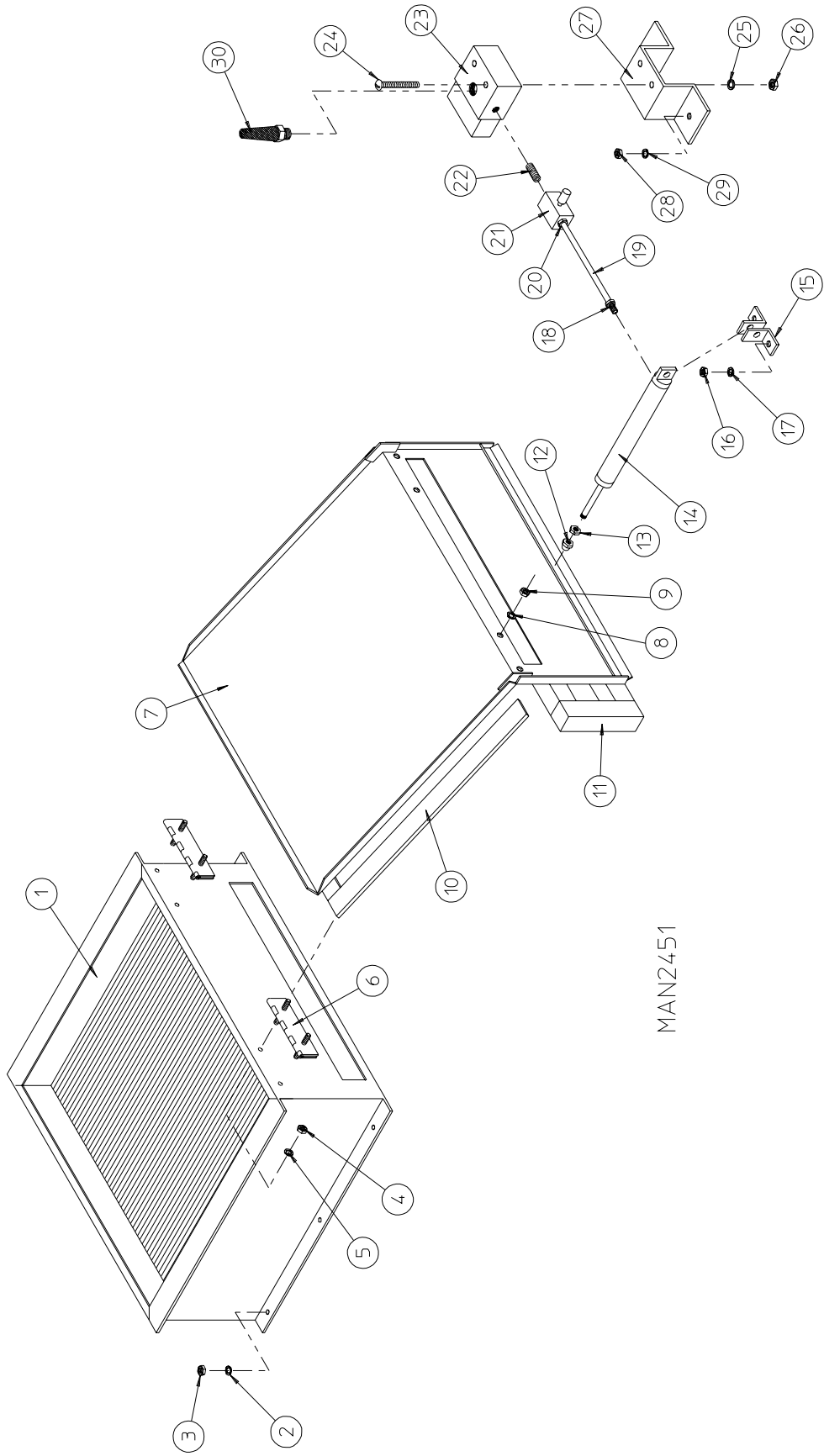

MAN2451

Illus. No.	Part No.	Qty.	Description
1	165008	1	Steam Coil Assembly
2	153002	6	5/16" Lock Washer
3	152004	6	5/16-18 Hex Nut
4	152002	4	1/4-20 Hex Nut
5	153007	4	1/4" Lock Washer
6	820321	2	Steam Damper Hinge Assembly
7	803416	1	Steam Damper Assembly (includes illus. nos. 7, 10, and 11)
8	153007	4	1/4" Lock Washer
9	152002	4	1/4-20 Hex Nut
10	115995	60	Steam Damper Gasket (sold by the inch)
11	102350	1	Steam Damper Foam (68-1/2" length)
12	151006	1	5/16-24 Stainless Steel Acorn Nut
13	152051	1	5/16-24 Right Hand Jam Nut
14	100495	1	11/16" Dia. x 3" Stroke Piston
15	323365	2	Left and Right Piston Support
16	152002	2	1/4-20 Hex Nut
17	153007	2	1/4" Lock Washer
18	100472	1	1/4" x 1/8" Connector
19	143110	1	1/4" Tubing (sold by the foot)
20	100472	1	1/4" x 1/8" Connector
21	100496	1	1/8" Needle Valve
22	143238	1	1/8" Close Nipple
23	100498	1	3-Way Micro Valve - 24 VAC
24	150002	2	#6-32 x 1" Slotted Machine Screw
25	153010	2	#6 Star Washer
26	152000	2	#6-32 Hex Nut
27	330987	1	Micro Valve Support Bracket
28	152002	2	1/4-20 Hex Nut
29	153007	2	1/4" Lock Washer
30	100520	1	1/8" N.P.T. Silencer (muffler)

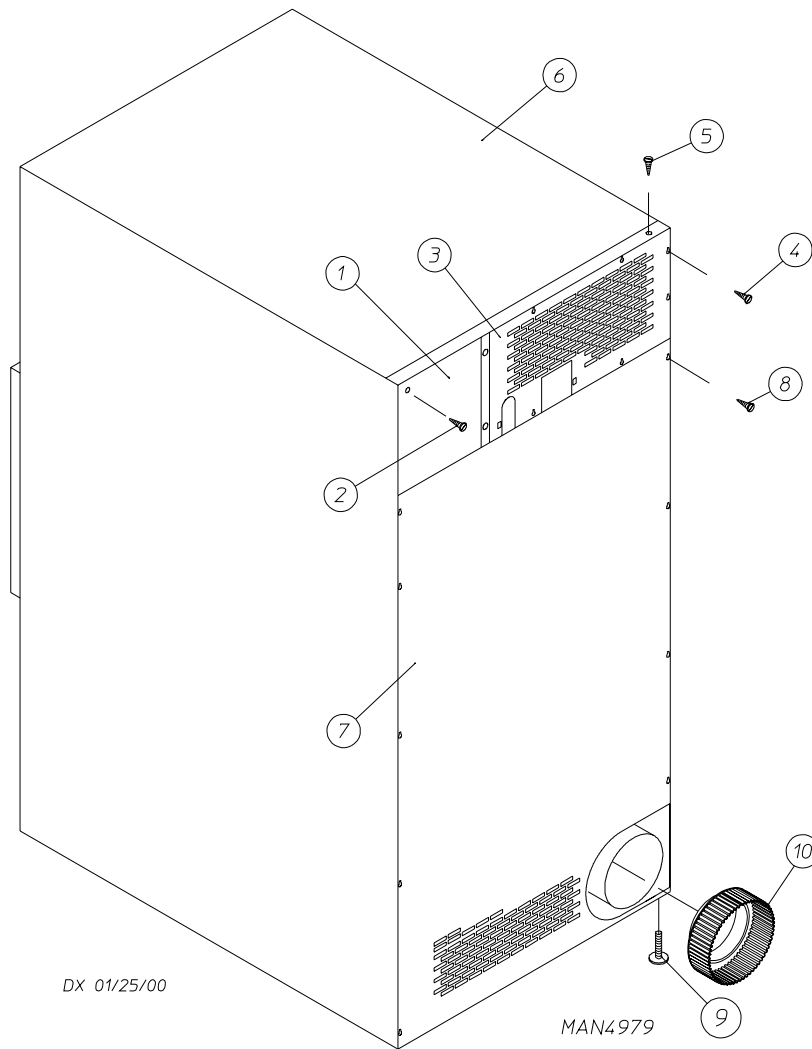

Illus. No.	Part No.	Qty.	Description
1	322809	1	Back Electrical Box Cover
2	150301	4	#8-18 x 7/16" Phillips Pan Head TEK Screw
3*	314424	1	Gas Top Back Guard
	314422	1	Electric Top Back Guard
4	150301	7	#8-18 x 7/16" Phillips Pan Head TEK Screw
5	150300	10	#10-16 x 1/2" Hex Washer TEK Screw
6*	322015	1	Outer Top
7	322082	1	Bottom Back Guard
	322018	1	Bottom Back Guard (for models mfd. as of March 19, 2001)
8	150301	13	#8-18 x 7/16" Phillips Pan Head TEK Screw
9	103500	4	Leveling Leg
10	882099	1	8" to 10" Transition Piece (for models mfd. prior to March 19, 2001)

* There is no outer top or top back guard on steam models.

NOTE: Coin acceptors listed include optical switch.
Replacement optic switch for Hanke acceptors is Part No. 881143.
Replacement optic switch for Greenwald acceptors is Part No. 137056.

Single Coin*

ADC Part No.	Nation	Description
882689	United States	25¢ Hanke Optic Coin Acceptor (for models mfd. as of June 15, 2000)
125100	U.S. and Canada	25¢ Greenwald Optic Coin Acceptor (for models mfd. prior to June 15, 2000)
125107	Australia	20¢ Greenwald Australian Optic Coin Acceptor
881768	Australia	\$1 Hanke Australian Optic Coin Acceptor
881604	Japan	100 Yen Hanke Optic Coin Acceptor
125103	---	0.882 Token Greenwald Optic Coin Acceptor
125121	---	0.800 Token Greenwald Optic Coin Acceptor
125133	Hong Kong	\$1 Greenwald Hong Kong Optic Coin Acceptor

Dual Coin*

881508	U.S. and Canada	10¢/25¢ Hanke Dual Optic Coin Acceptor
881842	Canada	25¢/\$1 Hanke Dual Optic Coin Acceptor
881542	United Kingdom	1£/20 Pence Hanke Dual Optic Coin Acceptor
881846	France	2/5 Franc Hanke Dual Optic Coin Acceptor
881541	Netherlands	25¢/1 Guilder Hanke Dual Optic Coin Acceptor

* Consult factory for coin acceptors not listed.

Kw	Voltage	Phase	Wire	Oven Assembly*	Element		Oven Wire			Terminal Lug		Bus Bar P/N: 121011	Oven Relay		Relay Coil Part No.	
					Qty.	Kw	Part No.	Qty.	Size	Part No.	Qty.		Part No.	Cat. No.		Part No.
24	460/480	3Ø	3 or 4	824951	6	4	120009	1	#8	882559	1	121010	2	DPA33	131352	N/A
24	416	3Ø	3 or 4	824945	6	4	120008	1	#8	882558	1	121010	2	DPA33	131352	N/A
24	240	3Ø	3	824932	6	4	120009	1	#6	882556	1	121010	1	DF35	131361	N/A
24	208	3Ø	3 or 4	824915	6	4	120008	1	#4	882553	1	121012	1	DPA63	131369	N/A
20	380	3Ø	3 or 4	824938	6	4	120008	1	#8	882559	1	121010	2	DPA33	131352	N/A
20	240	1Ø	2	824927	5	4	120009	1	#4	882552	1	121012	2	DPA73	131376	N/A
20	208	1Ø	2	824905	5	4	120008	1	#2	882562	1	121012	2	GE35	131385	131386
18	460/480	3Ø	3 or 4	824950	6	3	120007	1	#8	882559	1	121010	2	DPA33	131352	N/A
18	416	3Ø	3 or 4	824944	6	3	120006	1	#8	882559	1	121010	2	DPA33	131352	N/A
18	240	3Ø	3	824931	6	3	120007	1	#8	882558	1	121010	2	DPA43	131357	N/A
18	240	1Ø	2	824925	6	3	120007	1	#4	882552	1	121012	2	DPA73	131376	N/A
18	208	3Ø	3 or 4	824914	6	3	120006	1	#6	882556	1	121010	2	DF35	131361	N/A
18	208	1Ø	2	824903	6	3	120006	1	#4	882553	1	121012	2	DPA73	131376	N/A
15	380	3Ø	3 or 4	824937	6	3	120006	1	#8	882559	1	121010	2	DPA33	131352	N/A

* Oven assemblies **DO NOT** include oven relay (contactor). This item **must be** ordered separately. When ordering oven assembly complete, specify 3 or 4 wire when applicable as well as if dryer has microprocessor controls.

N/A = Not available.

Part No.	Description
114006	“WARNING - Fire Hazards” Label
112280	“Clean Lint Screen” Label
114001	“CAUTION - Exhaust/Lint Screen” Label
112533	“Phase 5 Coin Program Location Summary” Label
112284	“Phase 6 OPL Program Location Summary” Label
120100	3/8” Straight (BX) Connector
120300	3/8” x 45° (BX) Connector
120400	3/8” Red Jacket (BX) Insulator
120500	3/8” Jiffy Clip (BX retainer clip)
120600	3/8” Greenfield (BX)
120707	(2-position) Terminal Strip
120708	(3-position) Terminal Strip
120800	1/4” In-Line Connector
120802	Red Butt Connector
120902	#74B Wire Nut
120903	Crimp-On Wire Nut
121014	1/4” Insulated (female) Terminal
121026	Tab Receptacle Combination
121499	5-1/2” Harness Tie
121500	8” Harness Tie
122804	Manometer (hydro gauge) for Measuring Gas Pressure
404500	Almond Brush-In-Cap Bottle Touch-Up Paint
404502	White Brush-In-Cap Bottle Touch-Up Paint
404506	Beige Brush-In-Cap Bottle Touch-Up Paint
404507	Cornflower Blue Brush-In-Cap Bottle Touch-Up Paint
404513	Wrinkle Blue Brush-In-Cap Bottle Touch-Up Paint

