

Washer-Extractor

Cabinet Hardmount
Electronic Control
Refer to Page 3 for Models

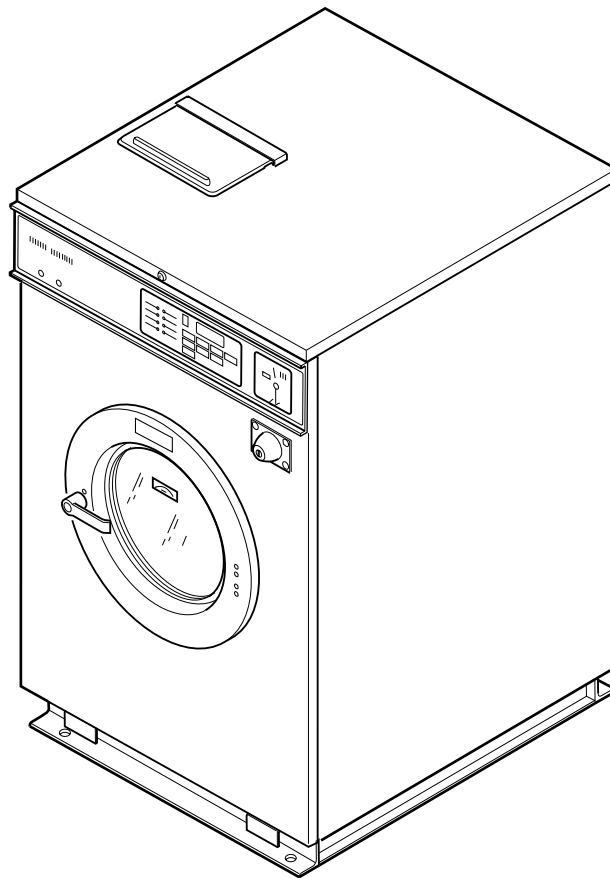

B003C

Parts

Table of Contents

Title	Page
Parts Ordering Information	2
Nameplate Location	2
Model Identification	3
Control Module Assembly	4
Control Module Assembly	6
Front Panels	8
Inner Front Panels	10
Panels (Page 1 of 2)	12
Panels (Page 2 of 2)	14
Door Assembly	16
Basket Assembly	18
Drain Assembly	20
Valve Assembly (Mueller)	22
Valve Assembly (Elbi)	24
Filter Assembly (Optional)	26
Motor Assembly	28
Motor	30
Door Lock Assembly	32
Supply Dispenser Assembly (Mueller)	34
Supply Dispenser Assembly (Elbi)	36
Fill Assembly	38
Parts Index	41

© Copyright 2000, Alliance Laundry Systems LLC

All rights reserved. No part of the contents of this book may be reproduced or transmitted in any form or by any means without the expressed written consent of the publisher.

Parts Ordering Information

Alliance Laundry Systems is not responsible for personal injury or property damage resulting from improper service. Review all service information before beginning repairs.

If literature or replacement parts are required, contact the source from whom the machine was purchased or contact Alliance Laundry Systems at (920) 748-3950 for the name of the nearest authorized parts distributor.

For technical assistance, call any of the following numbers:

(850) 718-1035
(850) 718-1026
Marianna, Florida
(920) 748-3121
Ripon, Wisconsin

Nameplate Location

When calling or writing about your product, be sure to mention model and serial numbers. Model and serial numbers are located on nameplate(s) as shown.

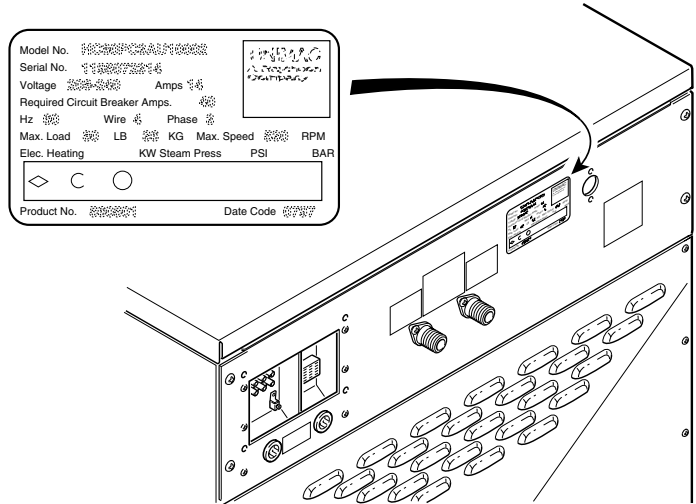

B155P

Model Identification

Information in this manual is applicable to these washer-extractors:

SC18EC2	SC18EP2	SC18NC2	SC18NP2	HC18NC2
SC25EC2	SC25EP2	SC25NC2	SC25NP2	HC25NC2
SC27EC2	SC27EP2	SC27NC2	SC27NP2	HC27NC2
SC35EC2	SC35EP2	SC35NC2	SC35NP2	HC35NC2
SC50EC2	SC50EP2	SC50NC2	SC50NP2	HC50NC2

Control Module Assembly

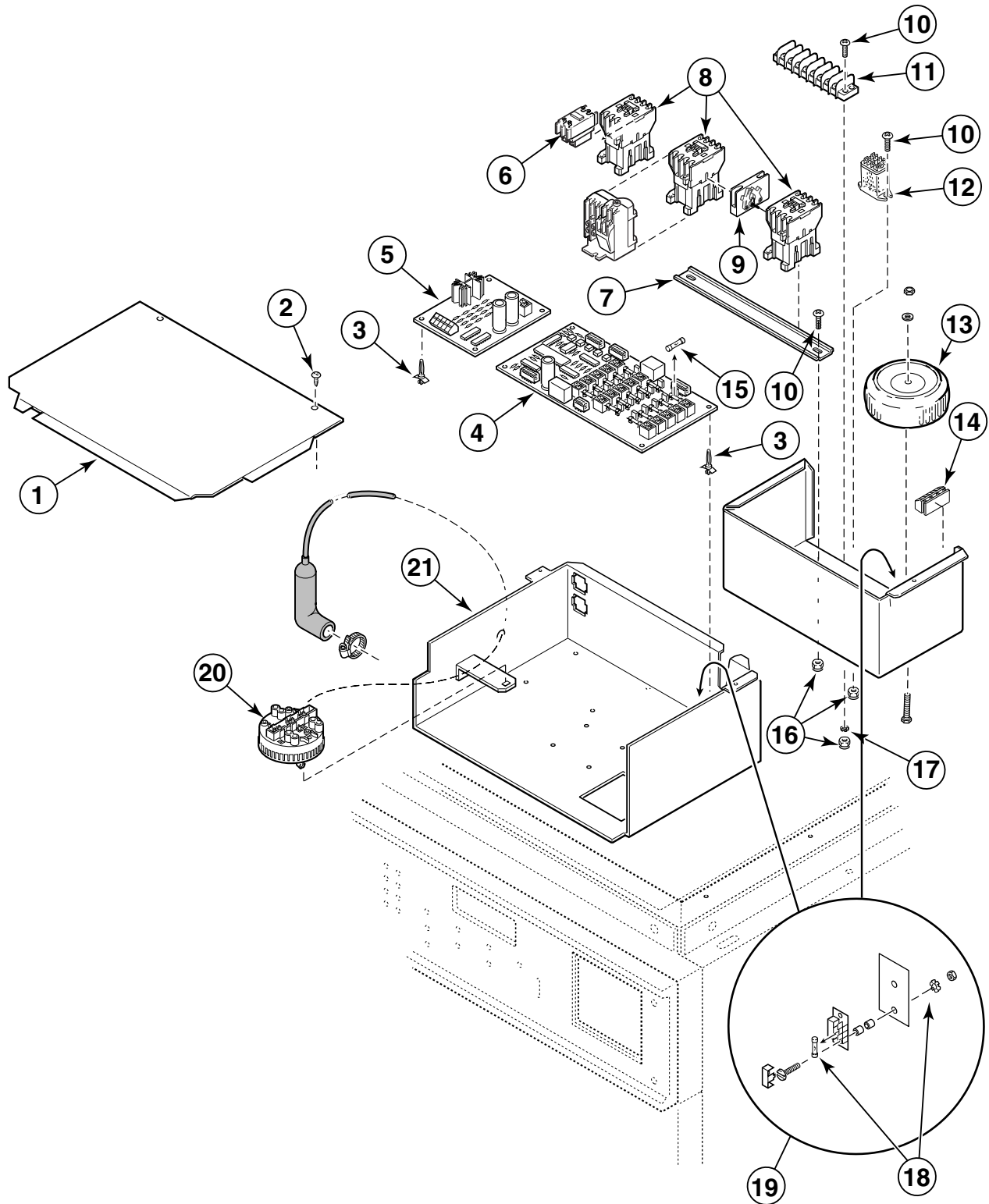

B181PE3A

Control Module Assembly

REF	PART #	DESCRIPTION	COMMENTS
	F631920	Bracket	
	F634318	Mounting Bracket Assembly	Single drop
	F635319	Mounting Bracket Assembly	Dual drop
1	F634175	Electrical Module Cover	
2	F430174	Screw	
3	F180506	Standoff	
4	F370433P	Output Relay Board	Use with F160200
	F370434P	Output Relay Board	Use with F160201
5	F370432	Door Lock Board	
6	F330145	Auxillary Contactor	Black/yellow or black/grey
	F330185	Auxillary Contactor	Grey
7	F610083	Mounting Rail	
8	F330165	Contactor	24 Volt; Black/yellow or black/grey
	F330176	Contactor	24 Volt; Grey
9	F330152	Mechanical Interlock	Clear
	F330186	Mechanical Interlock	Grey
10	F430917	Screw	
11	F140738	Terminal Strip	
12	M412534	Flange Relay	
13	F360153	Transformer	24 Volt
14	F140768	Terminal	
15	F350117	Fuse	2 Amp
	F350146	Fuse	5 Amp
16	F431022	Nut	
17	F431113	Washer	
18	F350115	Fuse	3 Amp
	F350138	Fuse	7 Amp
19	F350312	Dual Fuse Holder	
20	F340321	Water Level Switch	Tri-level, 35 and 50 models
	F340325	Water Level Switch	18-25
	F340312	Water Level Switch	27
	F340311	Water Level Switch	18-25 without heat
21	F634236-1	Control Module Box Assembly	EC/P models
	F634236	Control Module Box	NC/P models

Control Module Assembly

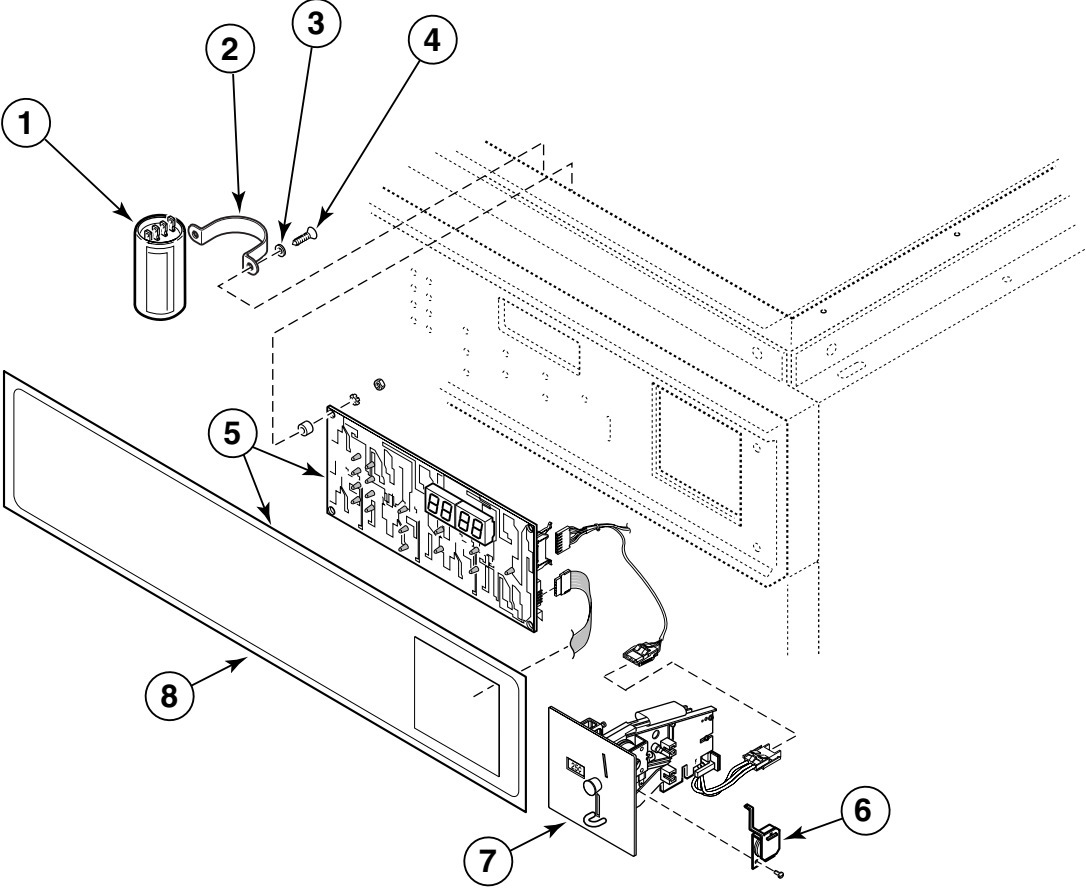

B184PE3A

Control Module Assembly

REF	PART #	DESCRIPTION	COMMENTS
1	F340002	Switch	
2	F340704	Bracket	
3	F430311	Washer	
4	F430916	Screw	
5	F160200	Control Assembly	High end electronic control; EC and EP Models
	F798721	Control Assembly Kit	Low end electronic control; EC and EP Models
	F160202	Control Assembly	NC/P models
6	F160712	Coin Blocking Solenoid	24 Volt; 50/60 Hertz
	F160713	Coin Meter Solenoid	
7	F650030	Coin Meter Assembly	U.S. quarter; EC models
	F160720	Coin Meter	U.S. quarter; NC models
	F160721	Coin Meter	U.K. 20/100p; NC models
	F160722	Coin Meter	2/10 French Francs; NC models
	F160723	Coin Meter	.20/1.00 Australia; NC models
	F160724	Coin Meter	100/500 yen; NC models
	F160725	Coin Meter	.886 token; NC models
	F160726	Coin Meter	1.000 token; NC models
	F160727	Coin Meter	.25 Canadian Quarter; NC models
	F160728	Coin Meter	.25/1.00 Canadian Quarter; NC models
8	F634809-1	Control Panel Assembly	18EC, 18EP, 25EC, 25EP
	F634825-1	Control Panel Assembly	27EC, 27EP
	F634828-1	Control Panel Assembly	35EC, 35EP
	F634831-1	Control Panel Assembly	50EC

Front Panels

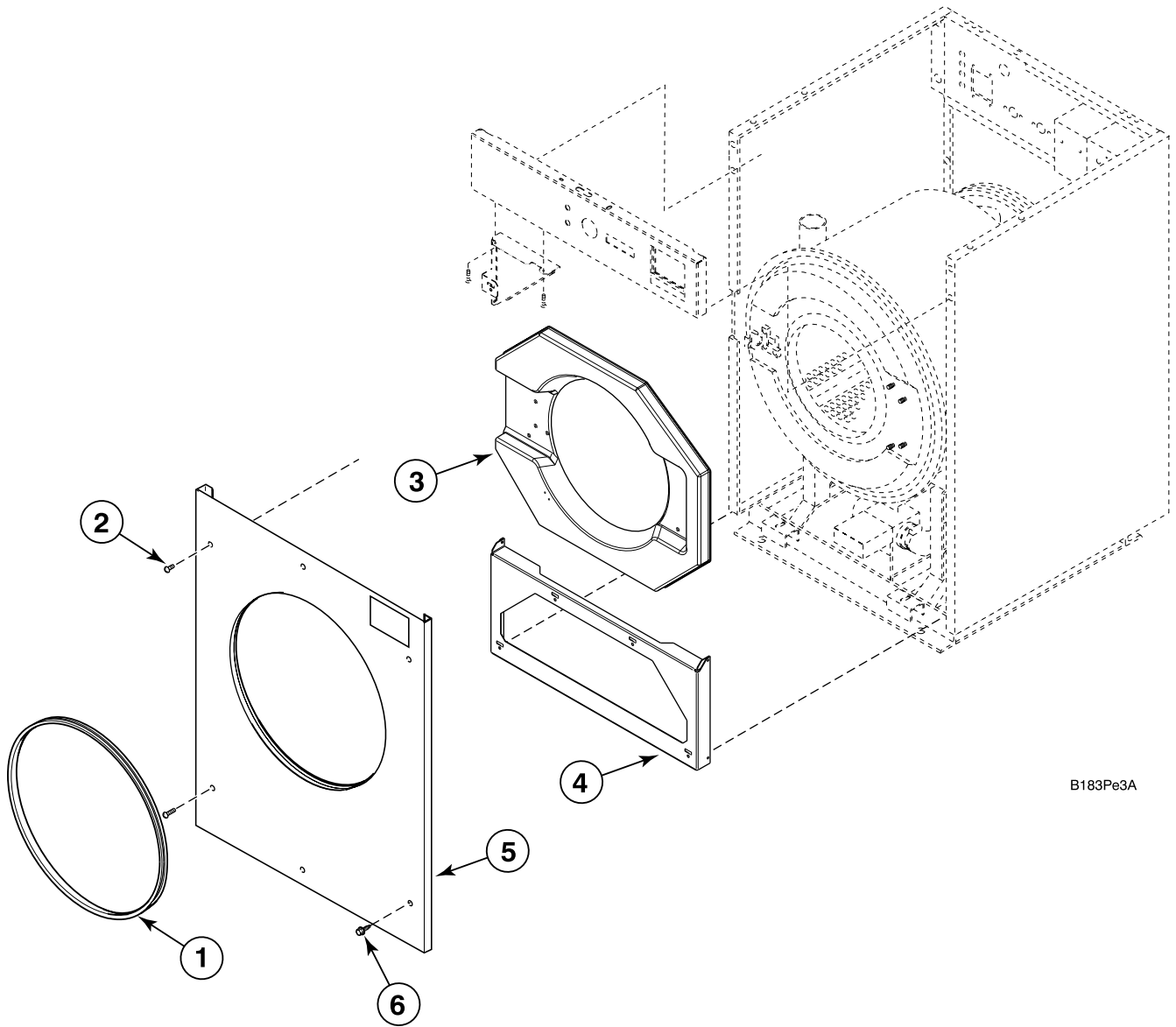

B183Pe3A

Front Panels

REF	PART #	DESCRIPTION	COMMENTS
1	F150452	Trim	Grey; Sold per foot
	F150452-1	Trim	Tan; Sold per foot
2	F430956	Screw	Sheet metal thread
	F430986	Screw	Machine thread
3	F634668-1	Bezel	SC18EC, SC18EP, SC25EC, SC25EP
	F634472-1	Bezel	SC27EC, SC27EP, SC35EC, SC35EP
	F634778-1	Bezel	SC50EC, SC50EP
4	F634800	Lower Brace	SC18EC, SC18EP, SC25EC, SC25EP
	F634801	Lower Brace	SC27EC, SC27EP
	F634802	Lower Brace	SC35EC, SC35EP
	F634803	Lower Brace	SC50EC, SC50EP
5	F757404	Front Panel Kit	SC18, White; Includes grey trim and machine thread screw
	F757405	Front Panel Kit	SC50; SS; Includes grey trim and machine thread screw
	F757406	Front Panel Kit	SC18, SS; Includes grey trim and machine thread screw
	F757408	Front Panel Kit	SC18, Almond; Includes grey trim and machine thread screw
	F757410	Front Panel Kit	SC25, White; Includes grey trim and machine thread screw
	F757413	Front Panel Kit	SC25, Almond; Includes grey trim and machine thread screw
	F757414	Front Panel Kit	SC25; SS; Includes grey trim and machine thread screw
	F757415	Front Panel Kit	SC35, White; Includes grey trim and machine thread screw
	F757418	Front Panel Kit	SC35, Almond; Includes grey trim and machine thread screw
	F757419	Front Panel Kit	SC35, SS; Includes grey trim and machine thread screw
	F757422	Front Panel Kit	SC50, Almond; Includes grey trim and machine thread screw
	F757423	Front Panel Kit	SC50, White; Includes grey trim and machine thread screw
	F757484-01	Front Panel Kit	SC27; SS; Includes grey trim and machine thread screw
	F757484-02	Front Panel Kit	SC27, Almond; Includes grey trim and machine thread screw
	F757484-05	Front Panel Kit	SC27, White; Includes grey trim and machine thread screw
	F634501-1	Front Panel	SC35; Half inner front; Use for machines made 9/98
	F634398-	Front Panel	SC50; Half inner front; Use for machines made 6/00
	F634682-*	Front Panel	SC18EC
	F634683-*	Front Panel	SC18EP
	F634836-*	Front Panel	SC25EC
	F634837-*	Front Panel	SC25EP
	F634668-*	Front Panel	SC27EC
	F634666-*	Front Panel	SC27EP
F634816-*	Front Panel	SC35EC	
F634817-*	Front Panel	SC35EP	
F634764-*	Front Panel	SC50EC	
F634765-*	Front Panel	SC50EP	
6	F432293	Screw	Long; Used 9/98-6/99; *C35/50

*Denotes Color Outer Front Panel: -1 Stainless; -2 Almond; -5 White

Inner Front Panels

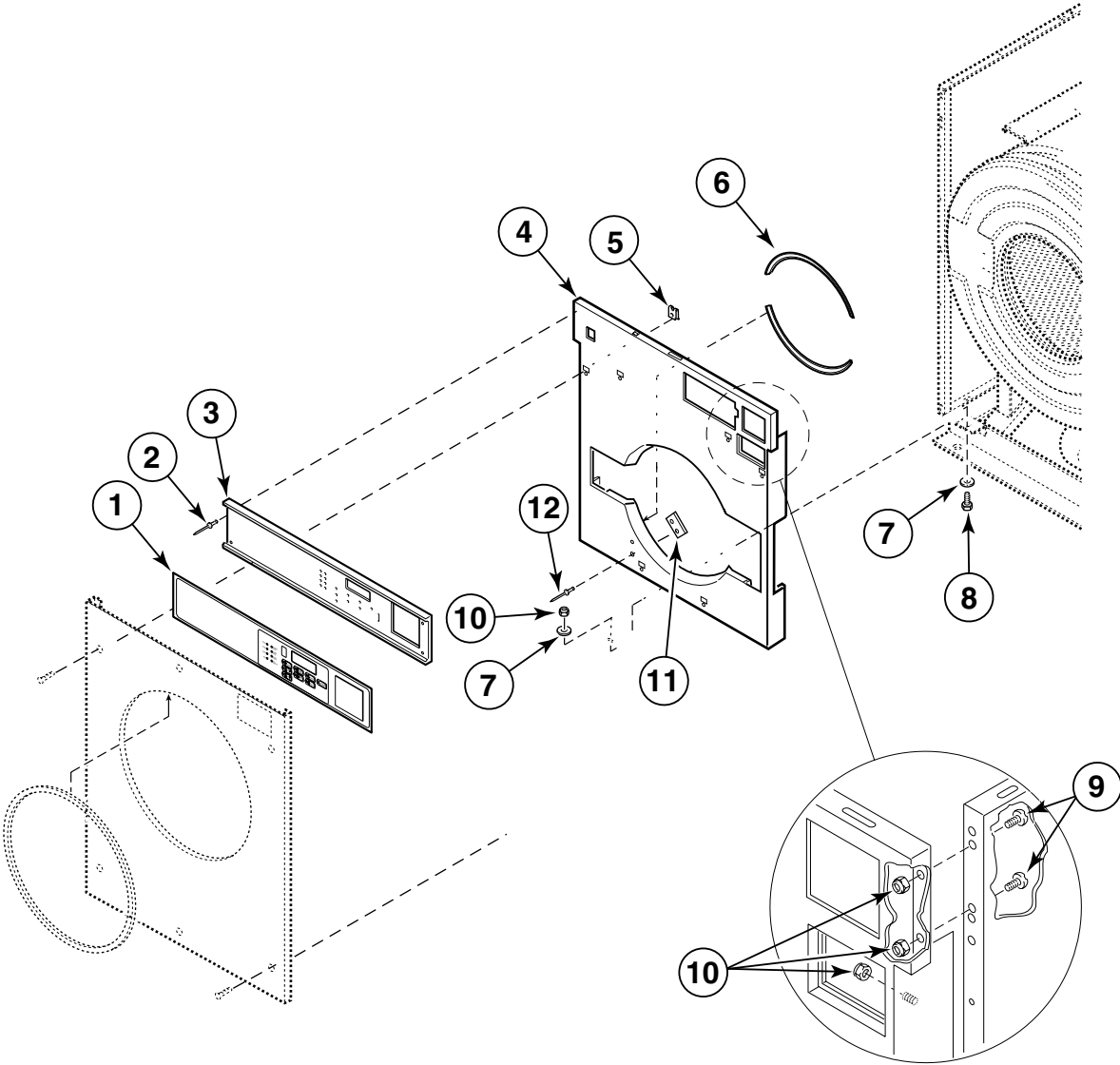

B156PE3E

Inner Front Panels

REF	PART #	DESCRIPTION	COMMENTS
1	F231489	Control Panel Decal	18EC, 18EP
	F231275	Control Panel Decal	25EC, 25EP
	F231490	Control Panel Decal	27EC, 27EP
	F231491	Control Panel Decal	35EC, 35EP
	F231492	Control Panel Decal	50EC, 50EP
	F231528-2	Decal	18/25NC, Dual drop control
	F231528-3	Decal	18/25NP, Control Panel
	F231527-2	Decal	27NC, Dual drop control
	F231527-3	Decal	27NP, Control panel
	F231526-2	Decal	35NC, Dual drop control
	F231526-3	Decal	35NP, Control panel
	F231525-2	Decal	50NC, Dual drop control
	F231525-3	Decal	50NP, Control panel
2	F431215	Rivet	
3	F150456	Control Panel	18 and 25
	F150457	Control Panel	27
	F150458	Control Panel	35
	F150459	Control Panel	50
4	F631685-1	Inner Front Panel Assembly	18
	F631687-1	Inner Front Panel Assembly	25
	F631688-1	Inner Front Panel Assembly	27
	F631689-1	Inner Front Panel Assembly	35
	F631690-1	Inner Front Panel Assembly	50
	F634505-1	Inner Front Panel Assembly	Upper half; 35
	F634462-1	Inner Front Panel Assembly	Upper half; 50
5	F430606	Tinnerman Nut	
6	F610203	Inner Front Panel Trim	18 and 25
	F610396	Inner Front Panel Trim	27 and 35
	F610106	Inner Front Panel Trim	50
7	F430317	Washer	
8	F430917	Screw	
9	F430925	Screw	
10	F430215	Nut	
11	F340702	Magnetic Switch	
12	F431217	Rivet	

Panels (Page 1 of 2)

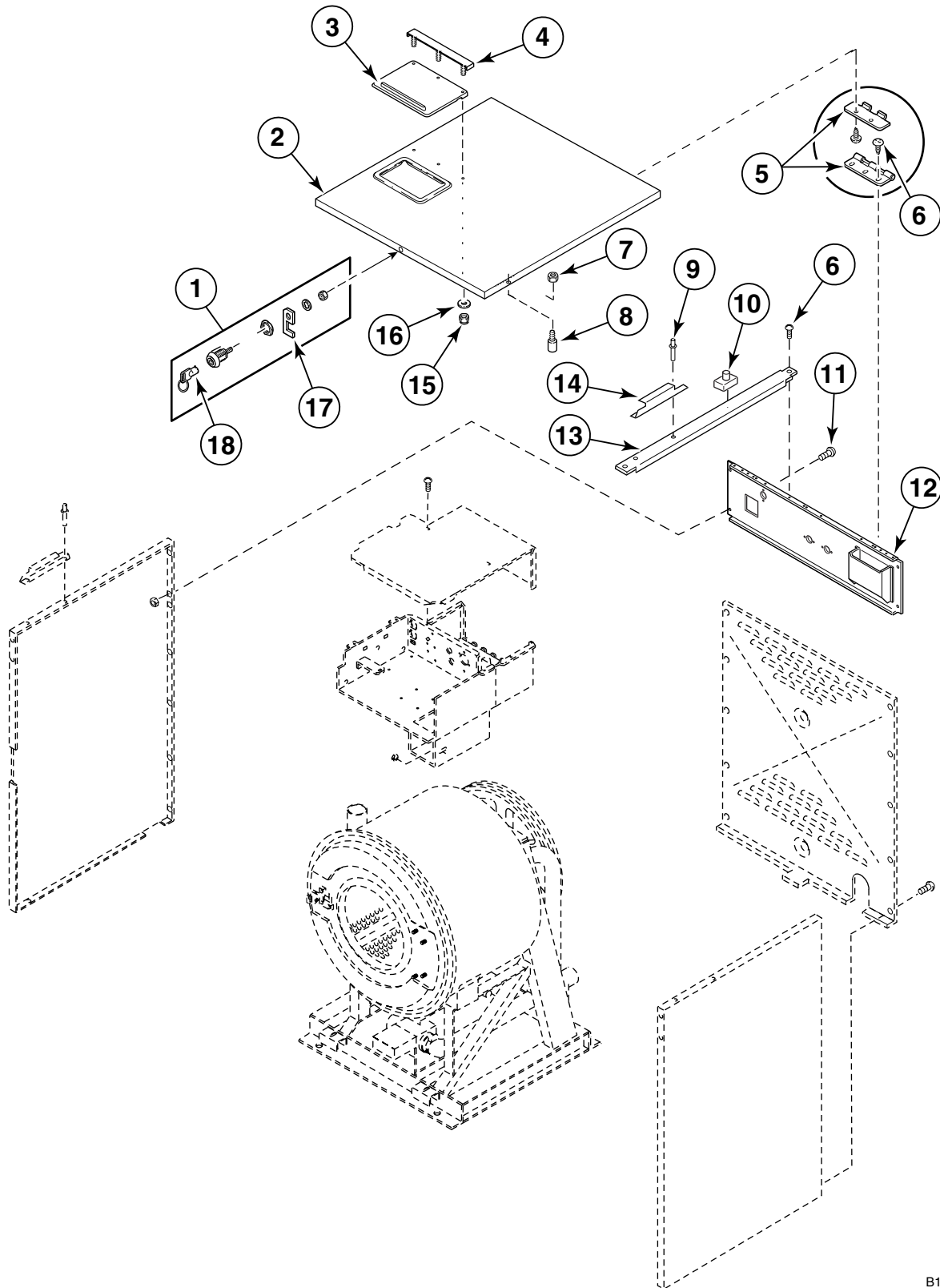

B157PE3A

Panels (Page 1 of 2)

REF	PART #	DESCRIPTION	COMMENTS
1	F190802	Top Cover Lock	GR3800, Barrel key
	F190805	Top Cover Lock	RL003, Flat key
2	F605997	Top Cover Subassembly	SC18
	F606956	Top Cover Subassembly	SC25
	F631962	Top Cover Subassembly	SC27
	F603745	Top Cover Subassembly	SC35
	F603801	Top Cover Subassembly	SC50
3	F150305-1	Soap Dispenser Cover	Tan
	F150305	Soap Dispenser Cover	Grey
4	F602729	Soap Dispenser Clamp	
5	F190203	Hinge	
6	F430174	Screw	
7	F430231	Nut	
8	F390300	Stud	
9	F431215	Rivet	
10	F340437	Top Cover Switch	
11	F430925	Screw	
12	F604117	Valve Panel Subassembly	SC18 and SC25; Mueller valve
	F631957	Valve Panel Subassembly	SC27; Mueller valve
	F603393	Valve Panel Subassembly	SC35; Mueller valve
	F604118	Valve Panel Subassembly	SC50; Mueller valve
	F633494-1	Valve Panel Subassembly	SC18 and SC25; Elbi valve
	F633494-2	Valve Panel Subassembly	SC27; Elbi valve
	F633494-3	Valve Panel Subassembly	SC35; Elbi valve
	F633494-4	Valve Panel Subassembly	SC50; Elbi valve
13	F602620	Top Brace	SC18
	F606239	Top Brace	SC25
	F631247	Top Brace	SC27
	F603014	Top Brace	SC35
	F603227	Top Brace	SC50
14	F602722	Dispenser Bracket	
15	F431005	Nut	
16	F431105	Washer	
17	F602753	Top Cover Latch Arm	
18	F160562	Service Key	GR3800; Barrel
	F190805-1	Service Key	RL003; Flat

Panels (Page 2 of 2)

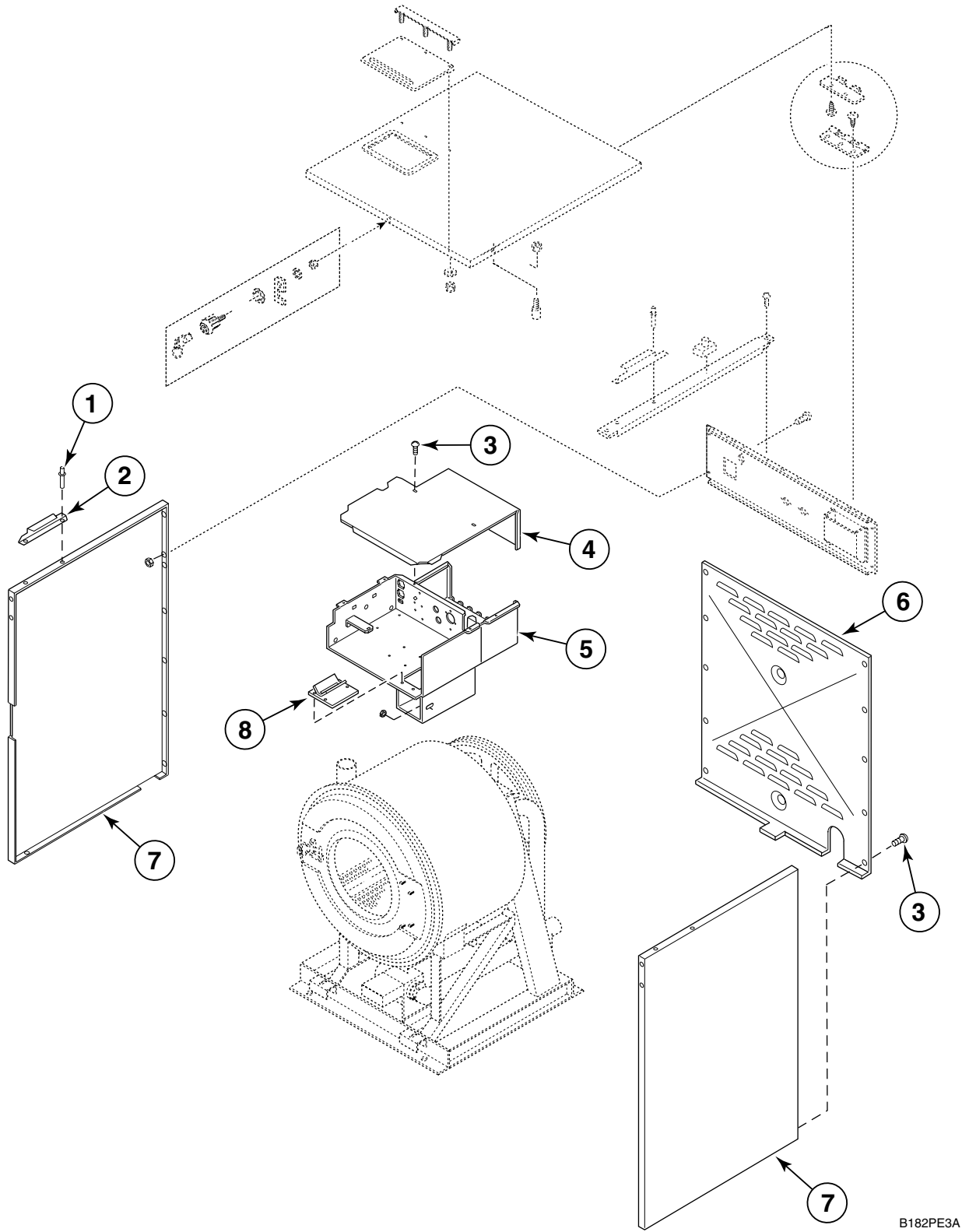

B182PE3A

Panels (Page 2 of 2)

REF	PART #	DESCRIPTION	COMMENTS
1	F431215	Rivet	
2	F602722	Soap Dispenser Bracket	
3	F430174	Screw	
4	F634175	Electrical Module Cover	
5	F634236-1	Control Module Box	
6	F602422	Rear Panel	SC18
	F606202	Rear Panel	SC25
	F630475	Rear Panel	SC27
	F603121	Rear Panel	SC35
	F603249	Rear Panel	SC50
7	F606544	Side Panel	SC18; Reversible; Used before May 23, 1999
	F607826	Side Panel	SC25; Reversible; Used before May 23, 1999
	F630469	Side Panel	SC27; Reversible; Used before May 23, 1999
	F634455-1	Side Panel	SC18; Reversible; Used after May 23, 1999
	F634475-1	Side Panel	SC25; Reversible; Used after May 23, 1999
	F634514-1	Side Panel	SC27; Reversible; Used after May 23, 1999
	F634500-1	Side Panel	SC35; Reversible; Used after May 23, 1999
	F634396-1	Side Panel	SC50; Reversible; Used after May 23, 1999
	F603017	Side Panel	SC35; Left
	F603130	Side Panel	SC50; Left
	F603016	Side Panel	SC35; Right
F603125	Side Panel	SC50; Right	
8	F632084	Coin Guide	SC18-50 EC models
	F634863	Coin Guide Assembly	SC18-50 NC; Dual drop models
	F635304	Coin Guide Assembly	SC18-50 NC; Single drop models

Door Assembly

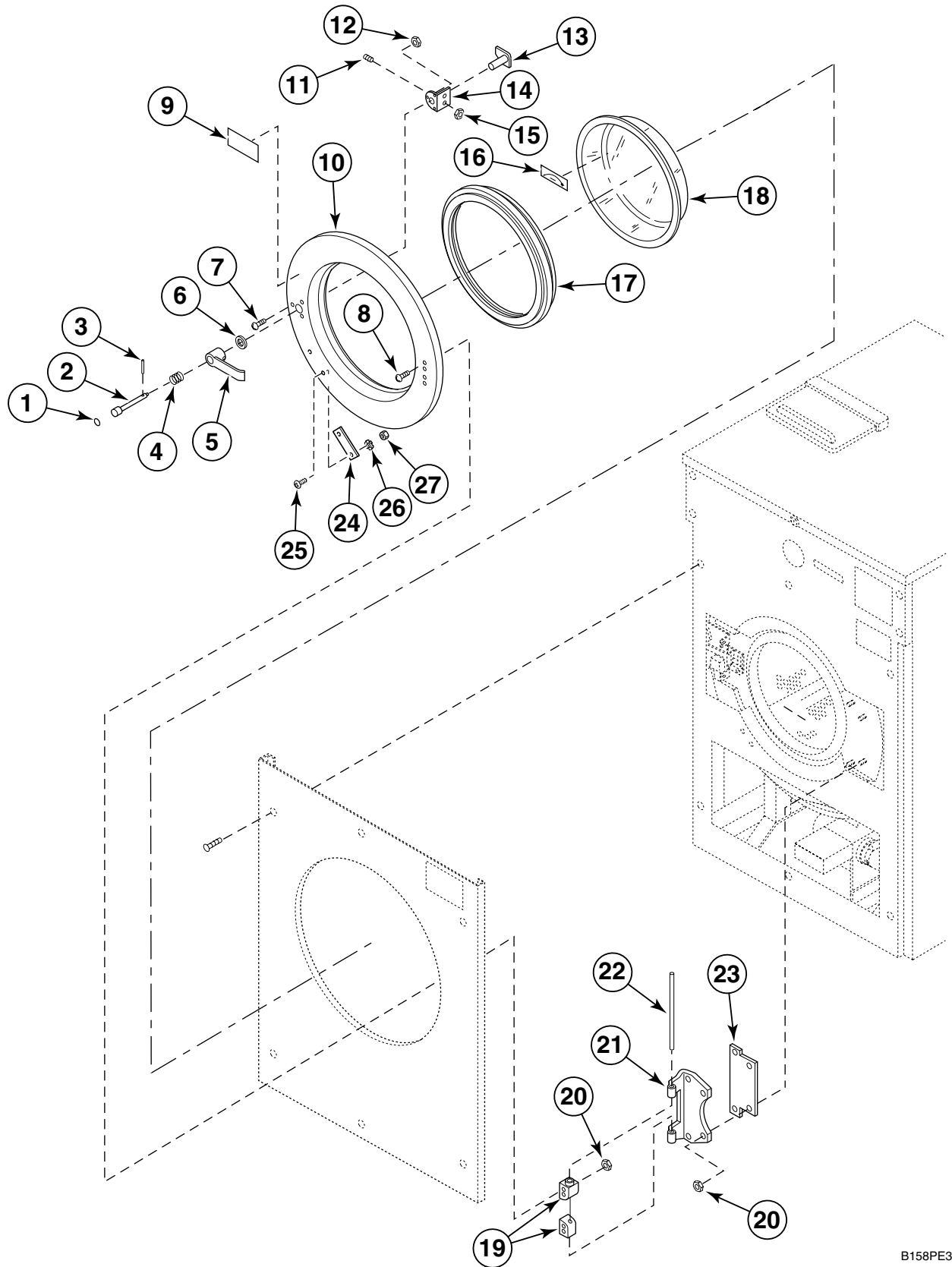

B158PE3B

Door Assembly

REF	PART #	DESCRIPTION	COMMENTS
1	F230662	Decal	Red dot
2	F320300	Push Button Rod	
3	F431222	Pin	
4	F310125	Door Lock Spring	
5	F150225	Door Handle	
6	F431907	Nylon Washer	
7	F430976	Screw	
8	F430906	Screw	
9	F230661	Decal	Push red button
10	F602431-1	Door	SC18 and SC25
	F602837-1	Door	SC27 and SC35
	F602842-1	Door	SC50
11	F430532	Screw	SC18 and SC25
	F430533	Screw	SC27, SC35, and SC50
12	F430232	Nut	
13	F150229	Latch Arm	
14	F150227	Door Handle Spacer	
15	F431041	Nut	
16	F230693	Decal	Counterclockwise rotation spin
17	F170106-1	Door Gasket	SC18 and SC25; Tan
	F170123-1	Door Gasket	SC27 and SC35; Tan
	F170124-1	Door Gasket	SC50; Tan
	F170106	Door Gasket	SC18 and SC25; Gray
	F170123	Door Gasket	SC27 and SC35; Gray
	F170124	Door Gasket	SC50; Gray
18	F290205P	Door Glass	SC18 and SC25
	F290207P	Door Glass	SC27 and SC35
	F290208P	Door Glass	SC50
19	F150226	Door Mount	
20	F430215	Nut	
21	F150224	Door Hinge	
22	F602813-2	Hinge Rod	SC18, SC25, SC27, and SC35
	F602813-3	Hinge Rod	SC50
23	F602679	Hinge Shim	Use as needed
24	F340703	Magnet	
25	F430916	Screw	
26	F431113	Lockwasher	
27	F431022	Nut	

Basket Assembly

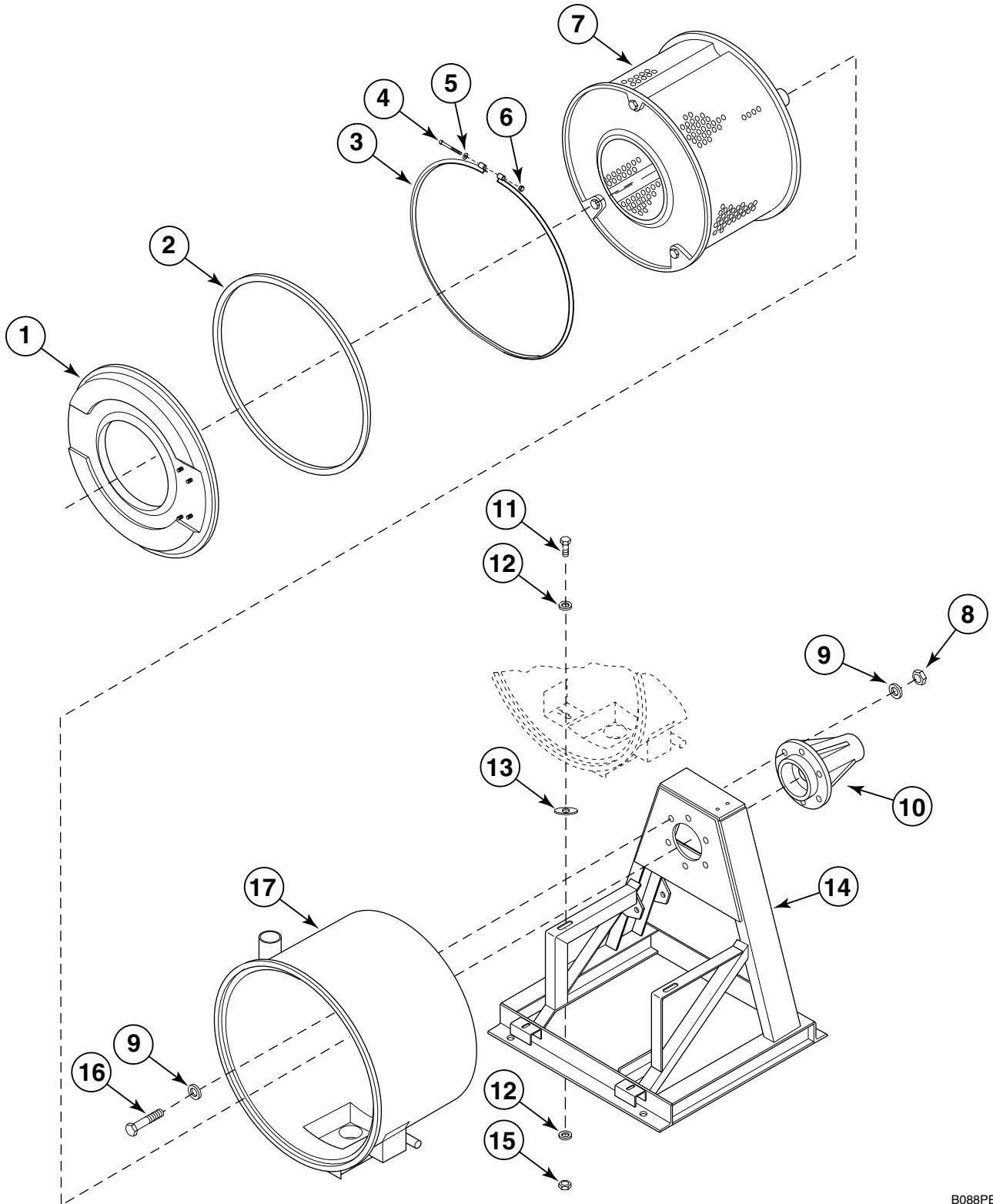

B088PE3B

Basket Assembly

REF	PART #	DESCRIPTION	COMMENTS
1	F609270-1	Shell Front Assembly	SC18 and SC25
	F632006	Shell Front Assembly	SC27
	F609271-1	Shell Front Assembly	SC35
	F609272-1	Shell Front Assembly	SC50
2	F170152	Shell Seal Gasket	Sold per foot
3	F602757	Shell Band Assembly	SC18 and SC25
	F631977	Shell Band Assembly	SC27
	F603229	Shell Band Assembly	SC35
	F603656	Shell Band Assembly	SC50
4	F430518	Bolt	
5	F430317	Washer	
6	F430215	Nut	
7	F602241-1	Basket Assembly	SC18
	F606214	Basket Assembly	SC25
	F631927	Basket Assembly	SC27
	F603225-1	Basket Assembly	SC35
	F603900-1	Basket Assembly	SC50
8	F430239	Nut	SC18 and SC25
	F430240	Nut	SC27, SC35, and SC50
9	F431128	Washer	SC18 and SC25
	F431131	Washer	SC27, SC35, and SC50
10	F747000	Trunnion Kit	SC18; Includes shell gasket and fasteners
	F747001	Trunnion Kit	SC25; Includes shell gasket and fasteners
	F747002	Trunnion Kit	SC27 and SC35; Includes shell gasket and fasteners
	F747004	Trunnion Kit	SC50; Includes shell gasket and fasteners
11	F430942	Bolt	
12	F430301	Washer	
13	F430303	Washer	
14	F607003	Frame Assembly	SC18
	F606178	Frame Assembly	SC25
	F630232	Frame Assembly	SC27
	F607004	Frame Assembly	SC35
	F607005	Frame Assembly	SC50
15	F430218	Nut	
16	F430949	Bolt	SC18 and SC25
	F430987	Bolt	SC27, SC35, and SC50
17	F634600	Standard Shell Assembly	SC18
	F634608	Standard Shell Assembly	SC25
	F634663	Standard Shell Assembly	SC27
	F606981	Standard Shell Assembly	SC35
	F634644	Standard Shell Assembly	SC50

Drain Assembly

REF	PART #	DESCRIPTION	COMMENTS
1	F200207	Clamp	#8
2	F200142	Air Trap	
3	F200215	Clamp	#28; SC18, SC25, SC27, and SC35
	F200213	Clamp	#40; SC50
4	F150317	Overflow Hose	SC18 and SC25
	F150332	Overflow Hose	SC27 and SC35
	F150417	Overflow Hose	SC50
5	F430927	Screw	SC18, SC25, SC27, and SC35
	F430103	Screw	SC50
6	F150318	Drain Connection Tee	SC18, SC25, SC27, and SC35
	F150398	Drain Connection Tee	SC50
7	F430215	Nut	
8	F200213	Clamp	#40; SC18, SC25, SC27, and SC35
	F200219	Clamp	#48; SC50
9	F150312	Front Drain Hose	SC18, SC25, SC27, and SC35
	F150400	Front Drain Hose	SC50
10	F150311	Rear Drain Hose	SC18
	F150331	Rear Drain Hose	SC25, SC27 and SC35
	F150399	Rear Drain Hose	SC50
11	F380618	Drain Valve	SC18; 2 inch, 120 Volt/60 Hertz/1 Phase
	F380619	Drain Valve	SC25, SC27, and SC35; 2 inch; 220 Volt
	F380629	Drain Valve	SC50; 3 inch; 220 Volt
12	F430231	Nut	
13	F380920	Valve Body	2 inch only
14	F380918	Main Drive Shaft & Seal Kit	
15	F380943	Drain Valve Motor	110 Volt/60 Hertz; Keyed shaft
	F380932	Drain Valve Motor	110 Volt/60 Hertz; Round shaft
	F380944	Drain Valve Motor	220 Volt/50 Hertz; Keyed shaft
	F380933	Drain Valve Motor	220 Volt/50 Hertz; Round shaft
	F380972	Drain Valve Motor	240 Volt/50-60 Hertz
16	F602761	Drain Valve Motor Cover	
17	F430910	Screw	

Valve Assembly (Mueller)

(Models Prior to 8-3-98)

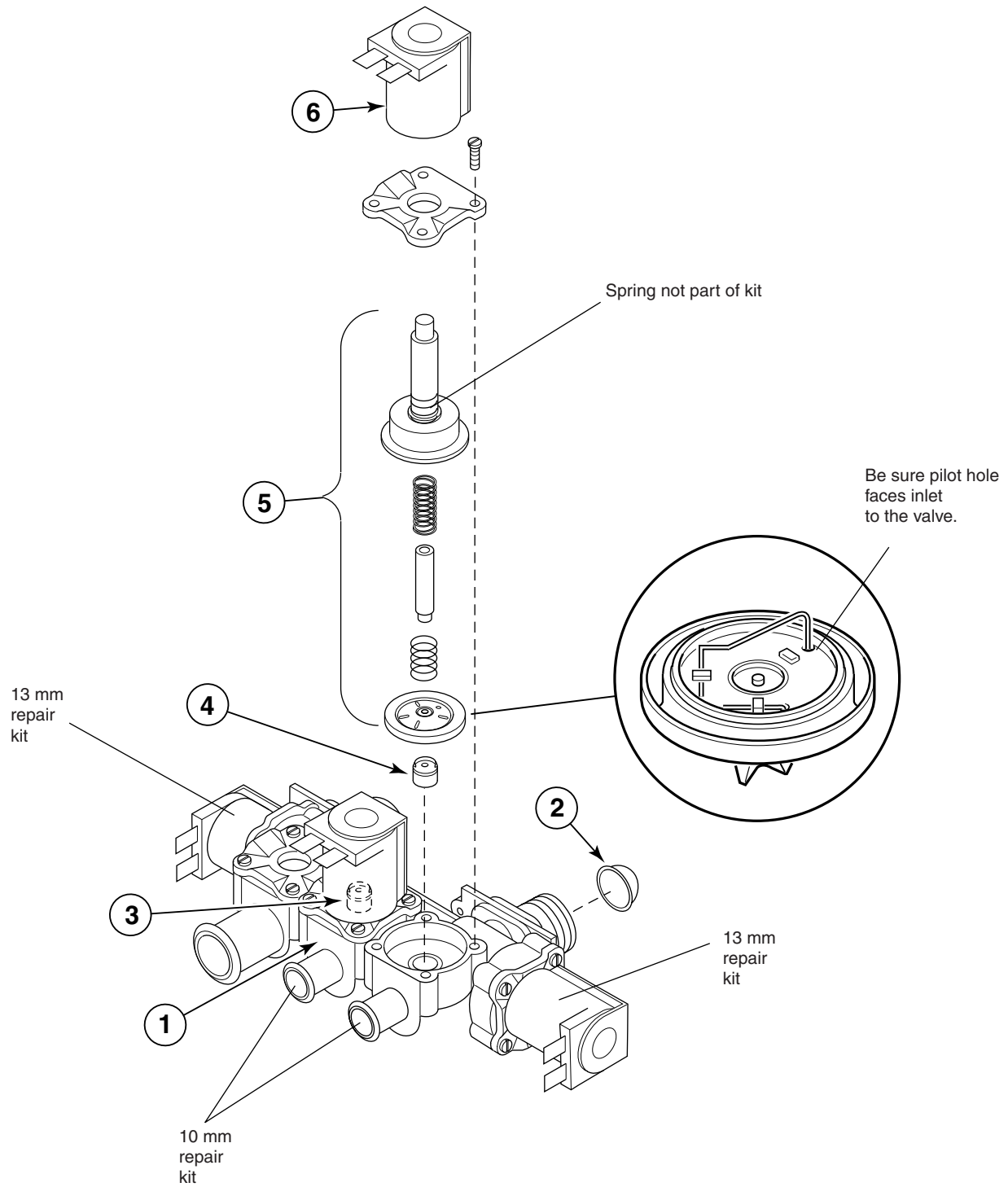

B090PE3B

Valve Assembly (Mueller)

(Models Prior to 8-3-98)

REF	PART #	DESCRIPTION	COMMENTS
1	F380795	3-Way Mixing Valve	Standard
	F380794	3-Way Mixing Valve	Metric
2	F270200	Valve Screen	
3	F380958	Flow Restrictor	4 millimeters
4	F380957	Flow Restrictor	2.8 millimeters
5	F380954	Repair Kit	10 millimeters; Top
	F380939	Repair Kit	13 millimeters; Ends
6	F380983	Coil	24 Volt

Valve Assembly (Elbi)

(After 8-3-98)

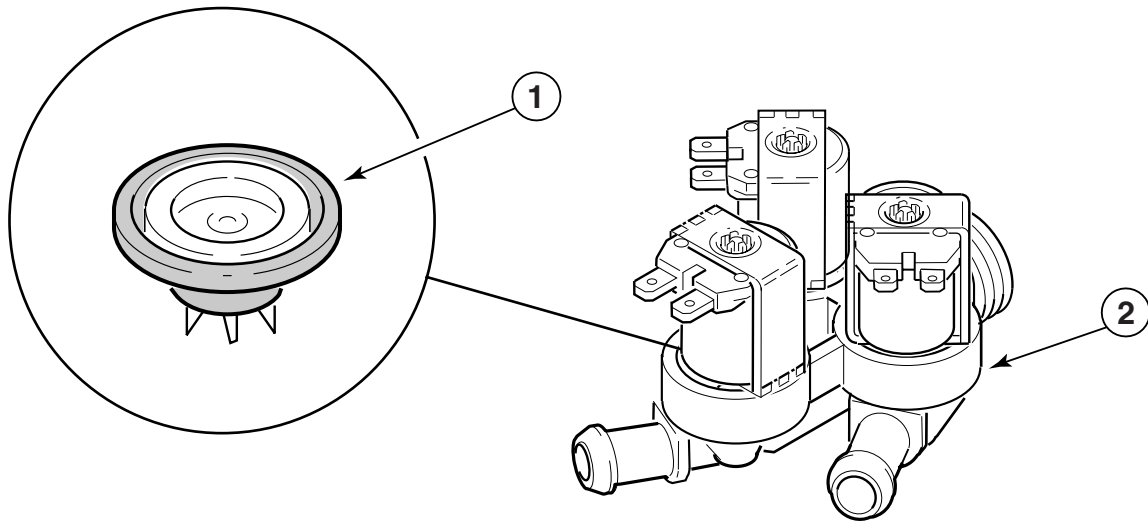

B171PE3B

Valve Assembly (Elbi)

(After 8-3-98)

REF	PART #	DESCRIPTION	COMMENTS
	G581P3	Repair Kit	Elbi Valve; Includes item 1 and G300194 Armature Guide
	F634857	Valve Assembly	Cold; Metric
	F634883	Valve Assembly	Hot; Metric;3.5L; Flow restrictor installed
1	G300202	Diaphram	
2	F381719	3-Way Mixing Valve	Cold; Hose Thread
	F381729	3-Way Mixing Valve	Hot; 3.5L; Flow restrictor installed; Hose thread

Filter Assembly (Optional)

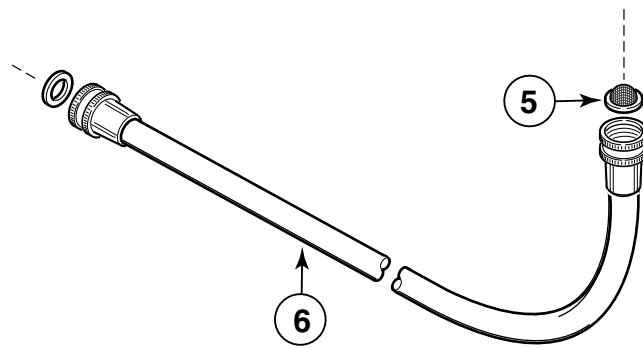
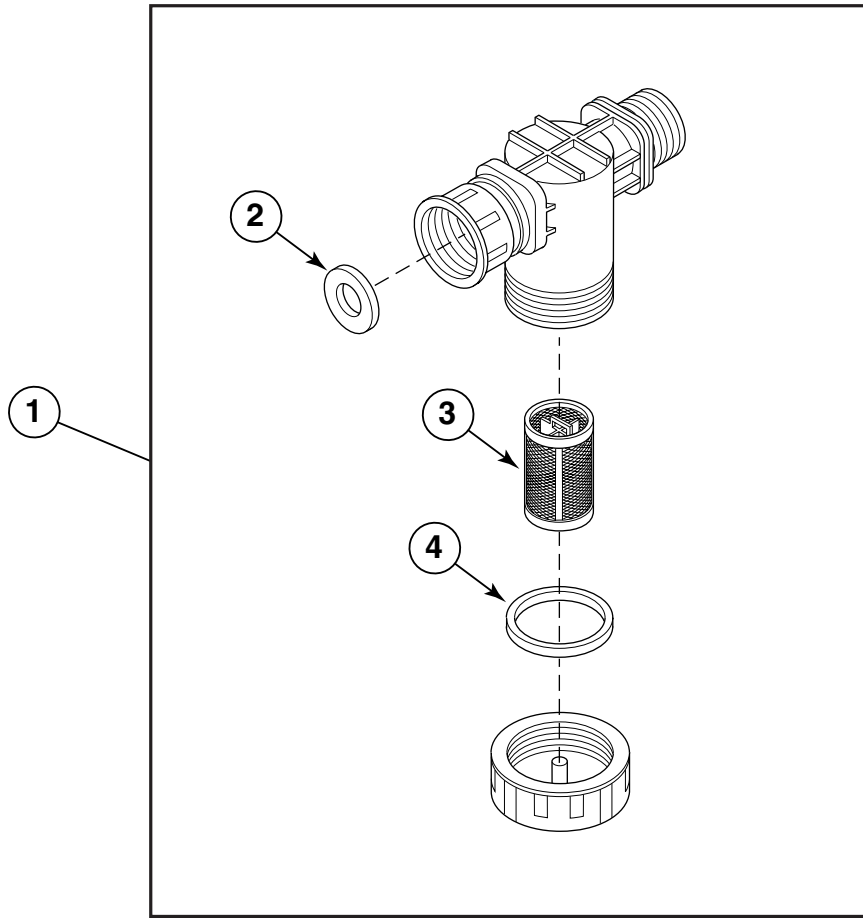

B091PE3B

Filter Assembly (Optional)

REF	PART #	DESCRIPTION	COMMENTS
1	F270306	Filter Assembly	Hose thread
	F270305	Filter Assembly	Metric
2	F200500	Washer	
3	F270406	Filter	.11 millimeters
	F270405	Filter	.25 millimeters
4	F270407	Gasket	
5	F270300	Hose Filter Washer	
6	F200116	Inlet Hose	3/8 inch
	F200164	Inlet Hose	3/4 inch
	F200165	Inlet Hose	3/8 inch; Metric
	F200166	Inlet Hose	3/4 inch; Metric

Motor Assembly

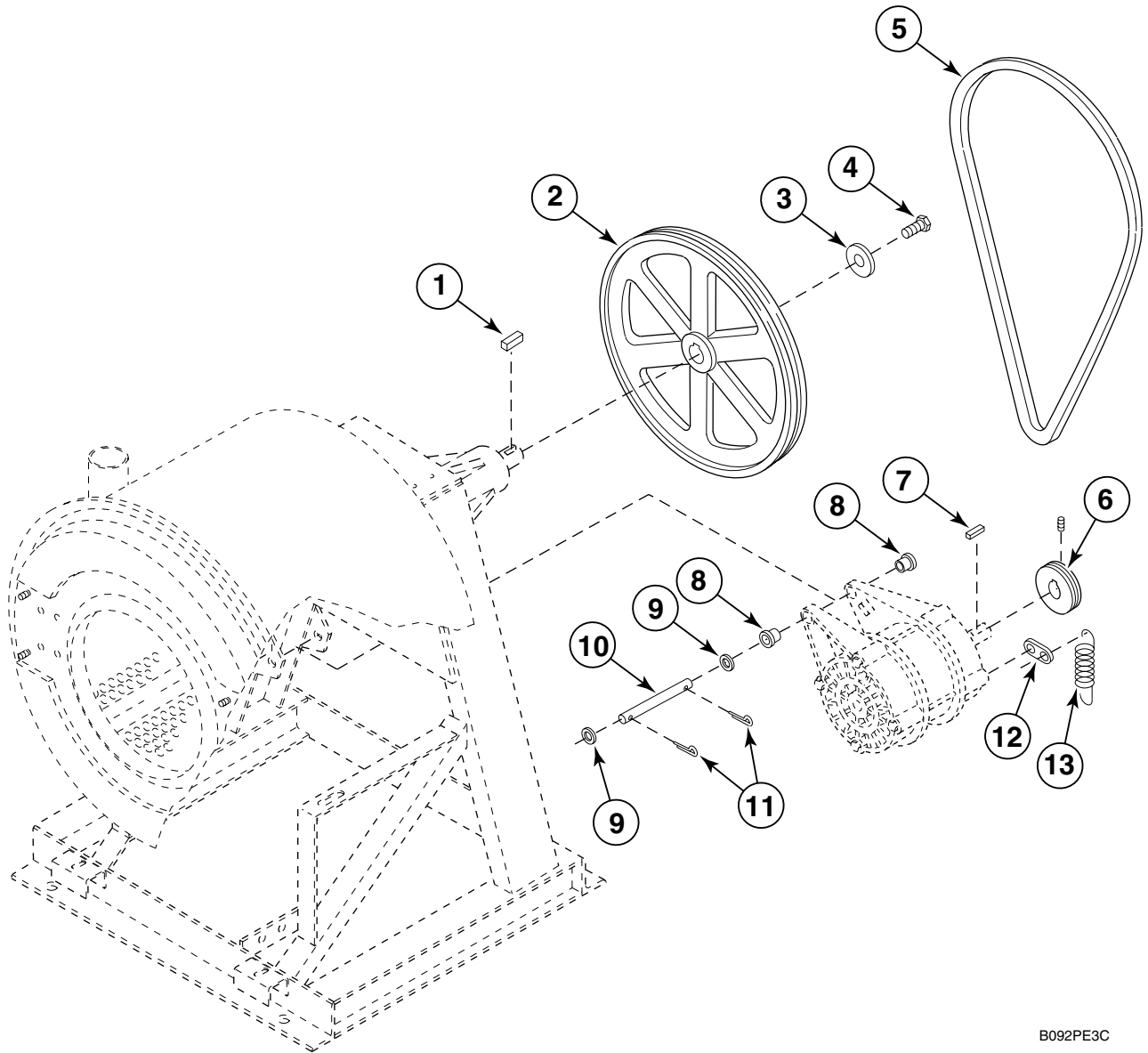

B092PE3C

Motor Assembly

REF	PART #	DESCRIPTION	COMMENTS
1	F430801	Key	
2	F280168	Basket Pulley	SC18 and SC25
	F280172	Basket Pulley	SC27 and SC35
	F280173	Basket Pulley	SC50
3	F431126	Washer	SC18, SC25
	F431115	Washer	SC27, SC35 and SC50
4	F430927	Screw	SC18 and SC25
	F430100	Screw	SC27, SC35, and SC50
5	F280337	Belt	SC18 and SC25; 60 Hertz
	F280343	Belt	SC18; 50 Hertz
	F280321	Belt	SC27; 50/60 Hertz
	F280341	Belt	SC35; 50 Hertz
	F280342	Belt	SC35; 60 Hertz
	F280304	Belt	SC50; 50/60 Hertz
6	F280170	Motor Pulley	SC18 and SC25; 60 Hertz
	F280184	Motor Pulley	SC18 and SC25; 50 Hertz
	F280185	Motor Pulley	SC27; 50 Hertz/ 1 Phase
	F280198	Motor Pulley	SC27; 60 Hertz/ 1 Phase
	F280186	Motor Pulley	SC50; 50 Hertz
	F280177	Motor Pulley	SC50; 60 Hertz
	F280284	Motor Pulley	SC27; 60 Hertz/ 3 Phase
	F280283	Motor Pulley	SC27; 50 Hertz/ 3 Phase
	F280279	Motor Pulley	SC27; 50 Hertz/ 1 Phase
	F280281	Motor Pulley	SC35; 60 Hertz
	F280282	Motor Pulley	SC35; 50 Hertz
7	F430802	Key	
8	F130311	Bushing	
9	F430325	Washer	
10	F602844	Motor Support Rod	SC18, SC25, and SC27
	F603059	Motor Support Rod	SC35
	F603897	Motor Support Rod	SC50
11	F430401	Cotter Pin	
12	F601515	Motor Spring Clip	
13	F310124	Belt Tension Spring	

Motor

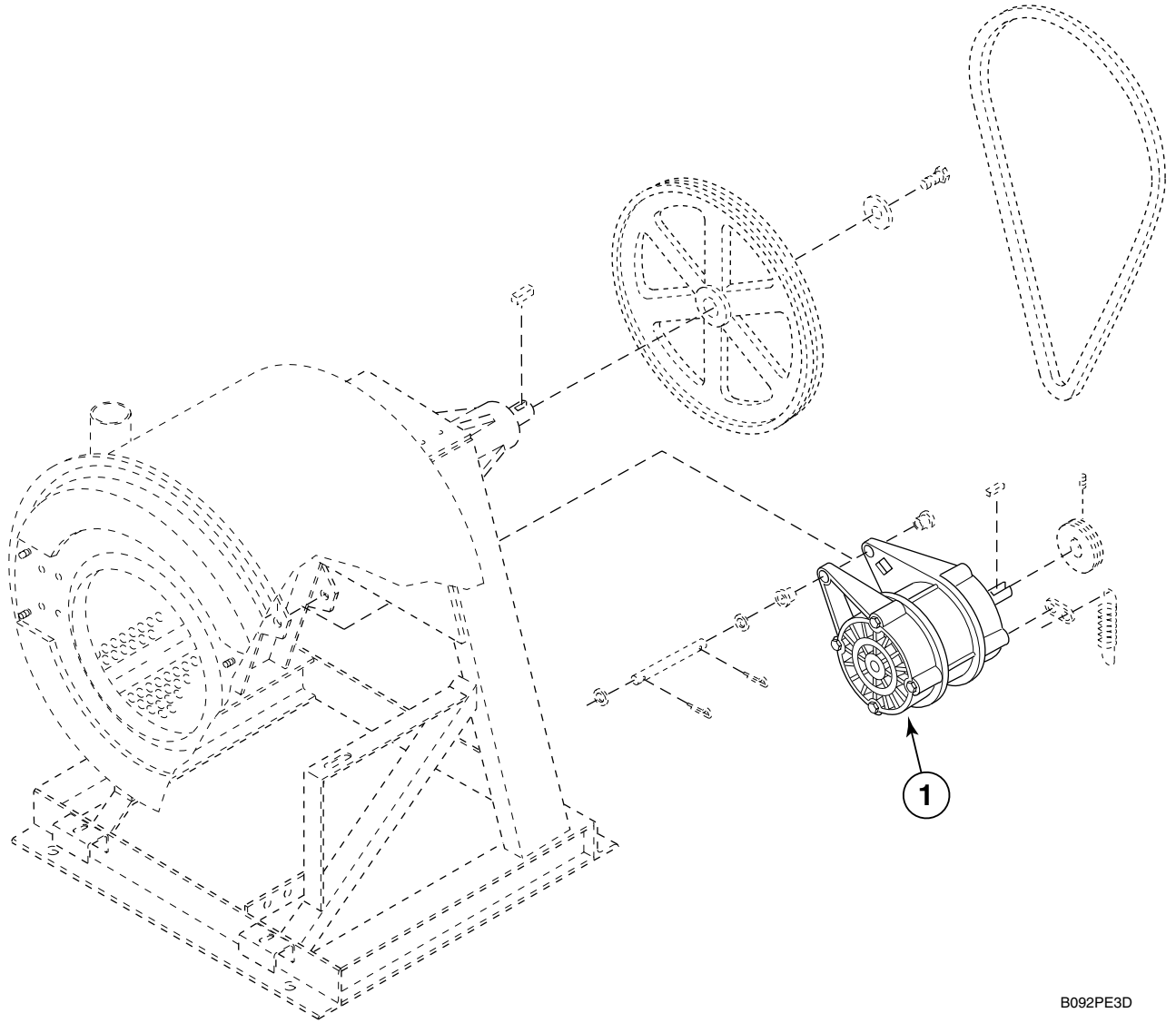

B092PE3D

Motor

REF	PART #	DESCRIPTION	COMMENTS
	F798725	Conversion Kit	SC35; Use with F220111
	F798726	Conversion Kit	SC25, SC27; Use with F220124
	F798727	Conversion Kit	SC35; Use with F220321
	F798728	Conversion Kit	SC50; Use with F220322
	F798729	Conversion Kit	SC25, SC27; Use with F220387
	F798731	Conversion Kit	SC50; Use with F220120
	F798733	Conversion Kit	SC18; Use with F220128
	F798734	Conversion Kit	SC18; Use with F220325
	F798735	Conversion Kit	SC35; Use with F220326
	F798740	Conversion Kit	SC25 and SC27; Use with F220388
	F798742	Conversion Kit	SC18; Use with F220396
1	F220110	Motor	SC18; 120 Volt/ 60 Hertz/ 1 Phase
	F220128	Motor	SC18; 208/240 Volt/ 60 Hertz/ 1 Phase; Use with machines made prior to 11/8/99
	F220128-H	Motor	SC18; 208/240 Volt/ 60 Hertz/ 1 Phase; Use with machines made after 11/8/99
	F220320	Motor	SC18; 208/240 Volt/ 60 Hertz/ 3 Phase
	F220130	Motor	SC18; 220-240 Volt/50 Hertz/1 Phase
	F220325	Motor	SC18; 380-415 Volt/50 Hertz/3 Phase; Use with machines made prior to 12/20/99
	F220325-H	Motor	SC18 380-415 Volt/50 Hertz/3 Phase; Use with machines made after 12/20/99
	F220396-H	Motor	SC18; Use with machines made prior to 11/24/99
	F220124	Motor	SC25 and SC27; 208-240 Volt/ 60 Hertz/ 1 Phase; Use with machines made prior to 11/8/99
	F220124-H	Motor	SC25 and SC27; 208/240 Volt/ 60 Hertz/ 3 Phase; Use with machines made after 11/8/99
	F220387	Motor	SC25 and SC27; 208/240 Volt/ 60 Hertz/ 3 Phase; Use with machines made prior to 11/19/99
	F220387-H	Motor	SC25 and SC27; 208/240 Volt/ 60 Hertz/ 3 Phase; Use with machines made after 11/19/99
	F220125	Motor	SC25 and SC27; 220-240 Volt/ 50 Hertz/ 1 Phase
	F220388	Motor	SC25 and SC27; 380/415 Volt/ 50 Hertz/ 3 Phase; Use with machines made prior to 11/19/99
	F220388-H	Motor	SC25 and SC27; 380/415 Volt/ 50 Hertz/ 3 Phase; Use with machines made after 11/19/99
	F220111	Motor	SC35; 208/240 Volt/ 60 Hertz/ 1 Phase; Use with machines made prior to 10/22/99
	F220111-H	Motor	SC35; 208/240 Volt/ 60 Hertz/ 3 Phase; Use with machines made after 10/22/99
	F220321-H	Motor	SC35; 208/240 Volt/ 60 Hertz/ 3 Phase
	F220326-H	Motor	SC35; Use with machines made after 12/20/99
	F220120	Motor	SC50; 208/240 Volt/ 60 Hertz/ 1 Phase; Use with machines made prior to 11/19/99
	F220120-H	Motor	SC50; 208/240 Volt/ 60 Hertz/ 1 Phase; Use with machines made after 11/19/99
	F220322-H	Motor	SC50; 208/240 Volt/ 60 Hertz/ 3 Phase; Use with machines made after 12/22/99
	F798728	Motor	SC50; 208/24 Volt/ 60 Hertz/ 3 Phase; Use with machines made prior to 12/22/99
	F220354	Motor	SC50; 220/240 Volt/ 50 Hertz/ 3 Phase
	F220327	Motor	SC50; 380/415 Volt/ 50 Hertz/ 3 Phase

Door Lock Assembly

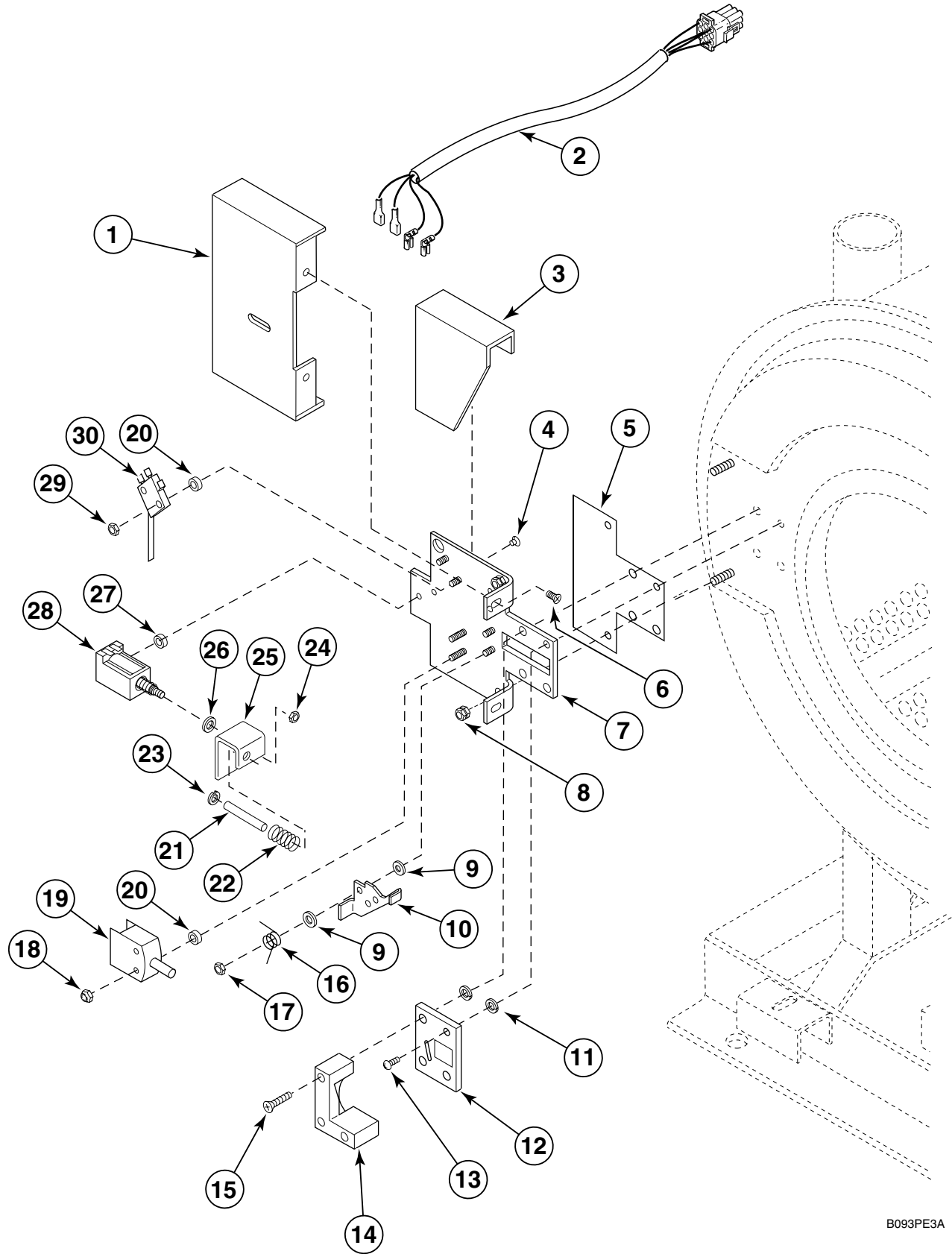

B093PE3A

Door Lock Assembly

REF	PART #	DESCRIPTION	COMMENTS
	F631532-1	Door Lock Assembly	SC18, SC25, SC27 and SC35; Includes door lock plate
	F631532-2	Door Lock Assembly	SC50; Includes Door Lock Plate
	F631532-3	Door Lock Assembly	SC18, SC25, SC27 and SC35; With heat; Includes door lock plate
	F631532-4	Door Lock Assembly	SC50; With heat; Includes door lock plate
1	F603003	Assembly	
2	F631986-1	Door Lock Wiring Harness	SC18, SC25, SC27, and SC35
	F631986-2	Door Lock Wiring Harness	SC50
3	F320200	Splash Shield	
4	F430977	Screw	
5	F603185	Plate	
6	F430174	Screw	
7	F633084	Door Lock Plate Subassembly	
8	F430215	Nut	
9	F431902	Washer	
10	F605381	Door Lock Lever	
11	F431100	Washer	
12	F602567	Plate Cover	
13	F430925	Screw	1/4"-20" x 1/2"
14	F150261	Catch	L-shaped
15	F430983	Screw	1/4"-20" x 1-1/2"
	F430982	Screw	1/4"-20" x 1-3/4"
16	F310110	Door Lock Torsion Spring	
17	F430232	Nut	
18	F430231	Nut	
19	F340200	Door Switch	
20	F431901	Washer	
21	F431231	Door Lock Pin	
22	F310137	Door Lock Pin Release Spring	
23	F310205	Retainer Ring	
24	F431017	Nut	
25	F150455	Pin Door Lock Linkage	
26	F431123	Washer	
27	F430977	Spacer	
28	F300125	Solenoid	
29	F430225	Nut	
30	F340923	Micro Door Lock Switch	

Supply Dispenser Assembly (Mueller)

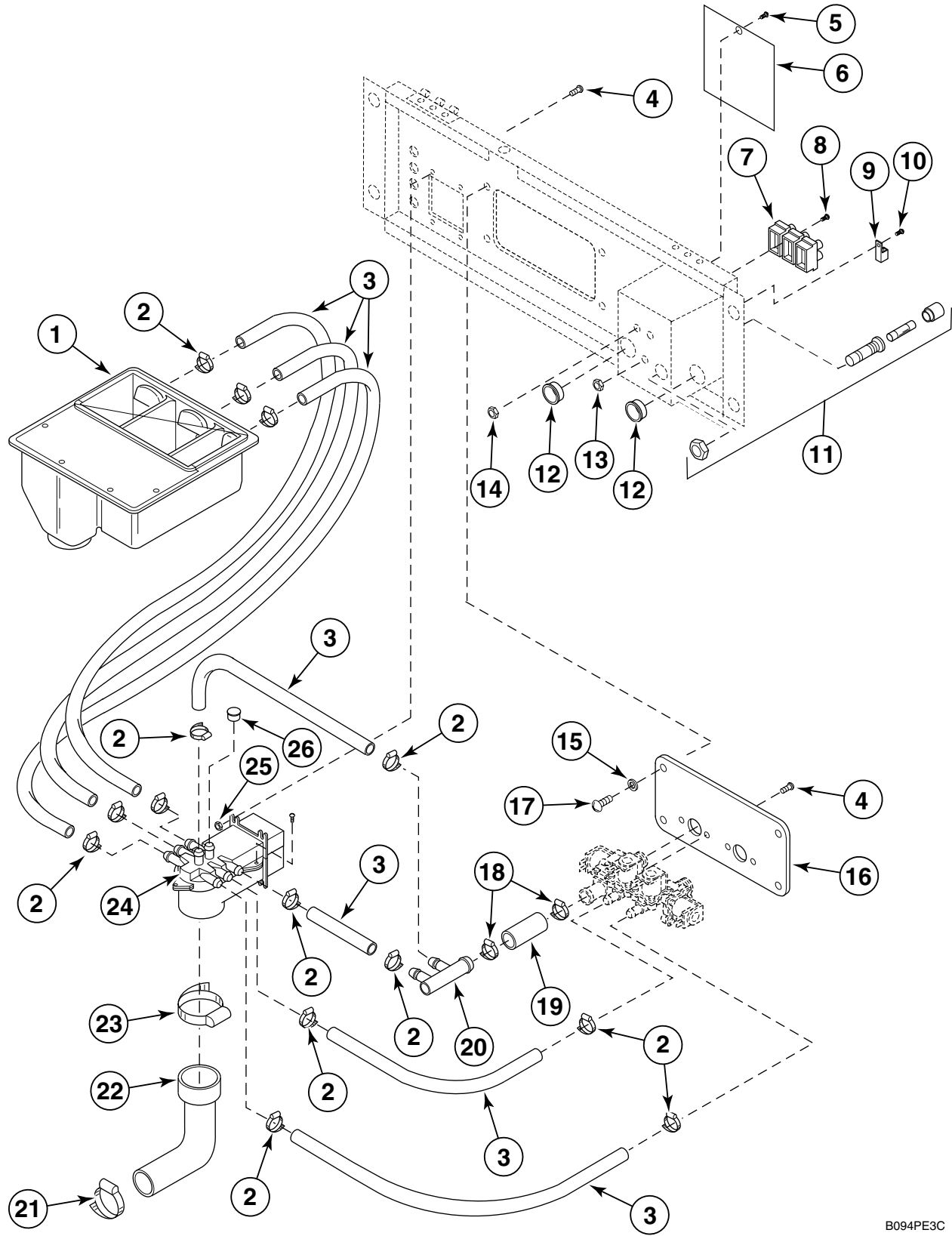

B094PE3C

Supply Dispenser Assembly (Mueller)

REF	PART #	DESCRIPTION	COMMENTS
1	F634377	Supply Dispenser	
2	F200207	Clamp	#8
3	F200108	Hose	Sold per foot
4	F430948	Screw	
5	F430174	Screw	
6	F602533	Junction Box Cover	
7	F140747	Input Power Block	3 wire
	F140746	Input Power Block	4 wire
8	F430938	Screw	
9	F140734	Ground Connector	
10	F430903	Screw	
11	F350312	Fuse Holder	
12	F140909	Bushing Grommet	
13	F430232	Nut	
14	F430231	Nut	
15	F430322	Washer	
16	F606595	Mixing Valve Mounting Plate	
17	F430929	Screw	
18	F200222	Clamp	#12
19	F606816-1	Hose	
20	F150371	Fill Connector Manifold	
21	F200213	Clamp	#40
22	F150321	Vacuum Breaker Hose	SC18 and SC35
	F150372	Vacuum Breaker Hose	SC25 and SC27
	F150340	Vacuum Breaker Hose	SC50
23	F200219	Clamp	#48
24	F603031	Vacuum Breaker Assembly	Includes screws
25	F430231	Nut	
26	F190301	Cap Plug	

Supply Dispenser Assembly (Elbi)

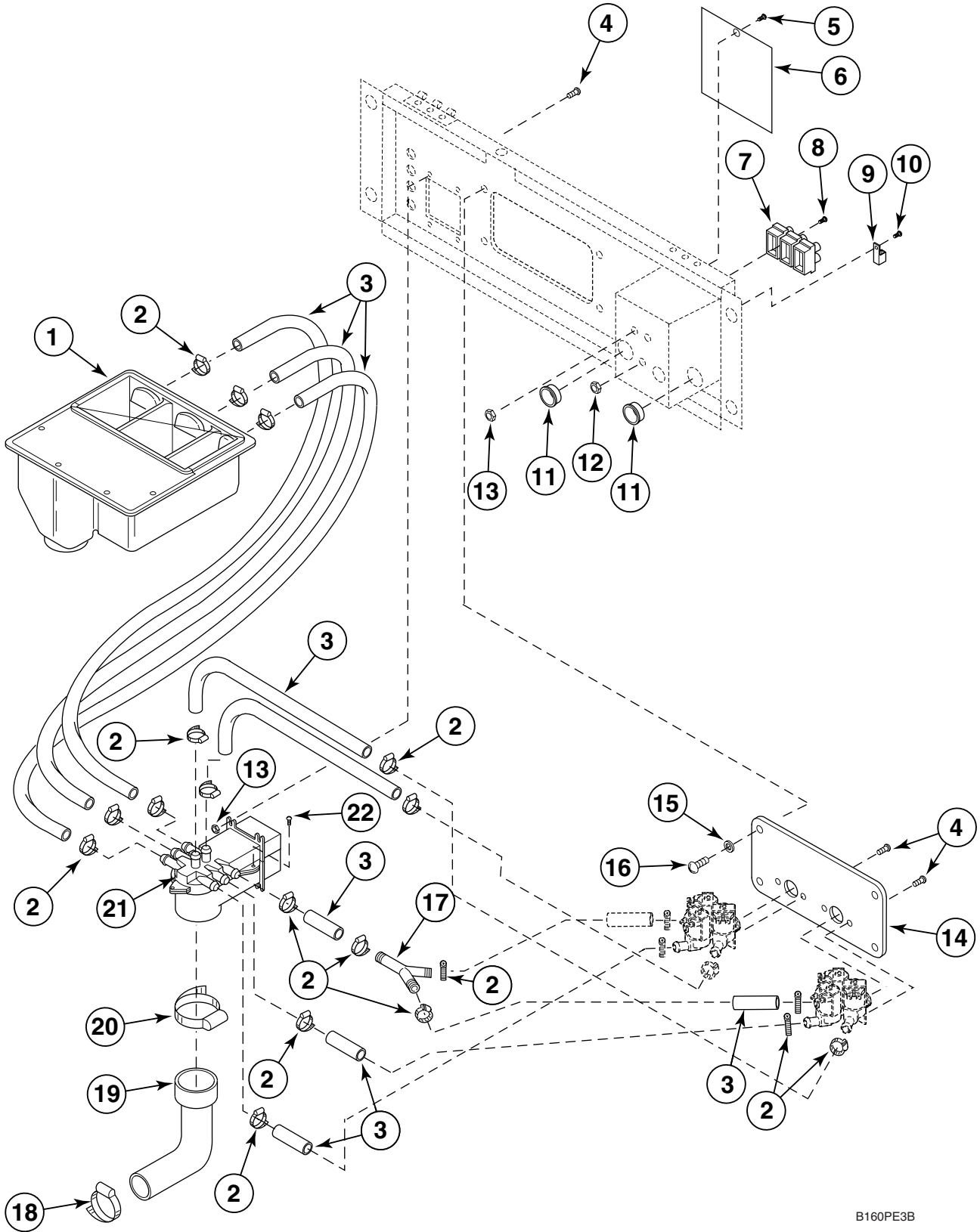

B160PE3B

Supply Dispenser Assembly (Elbi)

REF	PART #	DESCRIPTION	COMMENTS
1	F634377	Supply Dispenser	
2	F200207	Clamp	#8
3	F200108	Hose	Sold per foot
4	F430948	Screw	
5	F430174	Screw	
6	F602533	Junction Box Cover	
7	F140747	Input Power Block	3 wire
	F140746	Input Power Block	4 wire
8	F430938	Screw	
9	F140734	Ground Connector	
10	F430903	Screw	
11	F140909	Bushing Grommet	
12	F430232	Nut	
13	F430231	Nut	
14	F606595	Mixing Valve Mounting Plate	
15	F430322	Washer	
16	F430929	Screw	
17	F422808	"Y" Connector	
18	F200213	Clamp	#40
19	F150321	Vacuum Breaker Hose	SC18 and SC35
	F150372	Vacuum Breaker Hose	SC25 and SC27
	F150340	Vacuum Breaker Hose	SC50
20	F200219	Clamp	#48
21	F603031	Vacuum Breaker Assembly	
22	F430177	Screw	

Fill Assembly

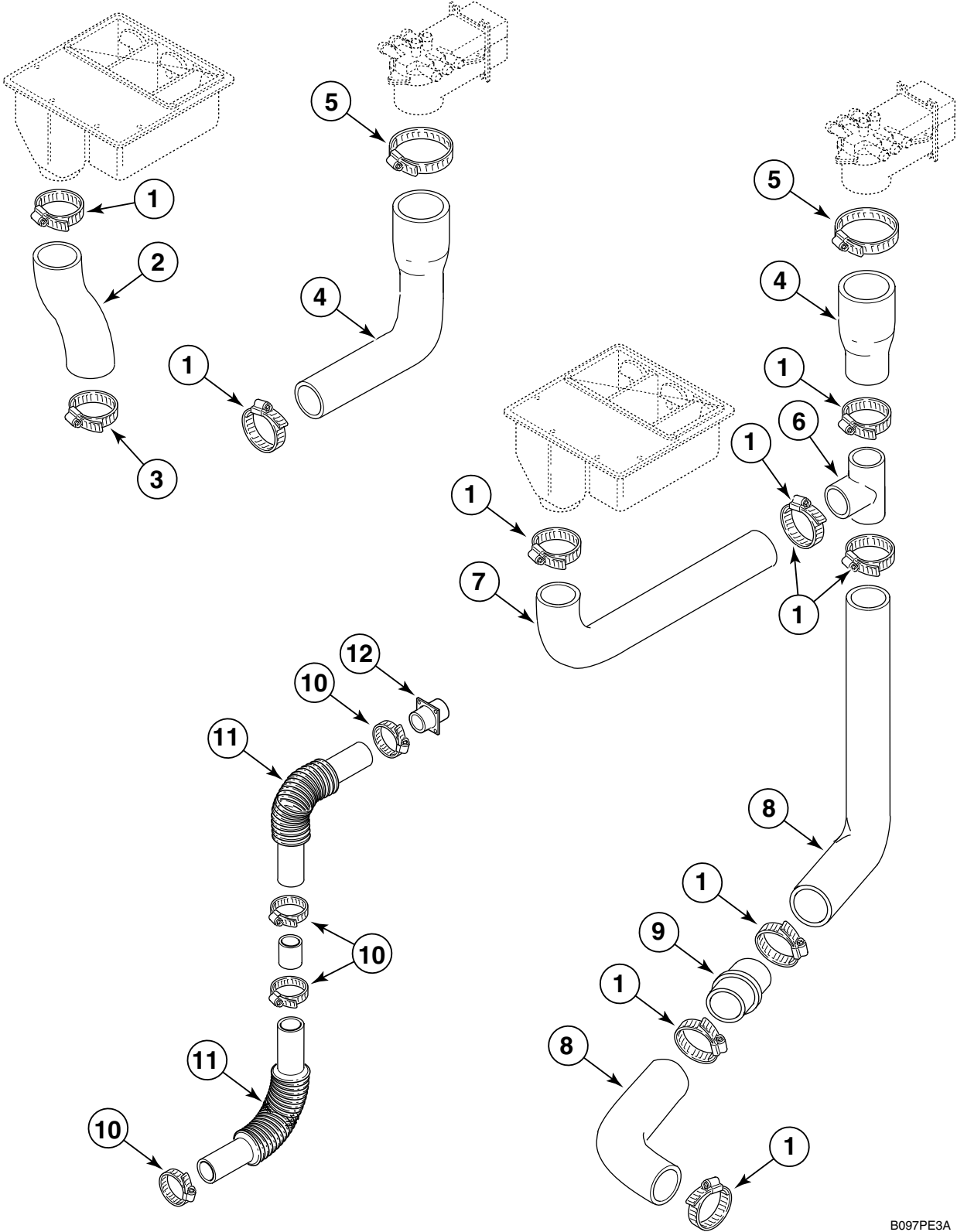

B097PE3A

Fill Assembly

REF	PART #	DESCRIPTION	COMMENTS
1	F200213	Clamp	#40
2	F150309	Supply Dispenser Hose	
3	F200415	Clamp	#36
4	F150321	Vacuum Breaker Hose	SC18 and SC35
	F150372	Vacuum Breaker Hose	SC25 and SC27
	F150340	Vacuum Breaker Hose	SC50
5	F200219	Clamp	#48
6	F422817	Tee	
7	F150331	Hose	SC27 only
8	F150414	Hose	SC27 only; Prior to 5-99
9	F608237	Coupling	SC27 only
10	F200204	Clamp	#20; SC27 only
11	F200170	Flex Hose	SC27 only
12	F422517	Vent	SC27 only

Parts Index

A

Air Trap	
F200142	21
Assembly	
F603003	33
Auxillary Contactor	
F330145	5
F330185	5

B

Basket Assembly	
F602241-1	19
F603225-1	19
F603900-1	19
F606214	19
F631927	19
Basket Pulley	
F280168	29
F280172	29
F280173	29
Belt	
F280304	29
F280321	29
F280337	29
F280341	29
F280342	29
F280343	29
Belt Tension Spring	
F310124	29
Bezel	
F634472-1	9
F634668-1	9
F634778-1	9
Bolt	
F430518	19
F430942	19
F430949	19
F430987	19
Bracket	
F340704	7
F631920	5
Bushing	
F130311	29
Bushing Grommet	
F140909	35, 37

C

Cap Plug	
F190301	35
Catch	
F150261	33
Clamp	
F200204	39
F200207	21, 35, 37
F200213	21, 35, 37, 39
F200215	21
F200219	21, 35, 37, 39

F200222	35
F200415	39
Coil	
F380983	23
Coin Blocking Solenoid	
F160712	7
Coin Guide	
F632084	15
Coin Guide Assembly	
F634863	15
F635304	15
Coin Meter	
F160720	7
F160721	7
F160722	7
F160723	7
F160724	7
F160725	7
F160726	7
F160727	7
F160728	7
Coin Meter Assembly	
F650030	7
Coin Meter Solenoid	
F160713	7
Contacto	
F330165	5
F330176	5
Control Assembly	
F160200	7
F160202	7
Control Assembly Kit	
F798721	7
Control Module Box	
F634236	5
F634236-1	15
Control Module Box Assembly	
F634236-1	5
Control Panel	
F150456	11
F150457	11
F150458	11
F150459	11
Control Panel Assembly	
F634809-1	7
F634825-1	7
F634828-1	7
F634831-1	7
Control Panel Decal	
F231275	11
F231489	11
F231490	11
F231491	11
F231492	11
Conversion Kit	
F798725	31
F798726	31
F798727	31
F798728	31
F798729	31
F798731	31
F798733	31
F798734	31

F798735	31
F798740	31
F798742	31
Cotter Pin	
F430401	29
Coupling	
F608237	39

D

Decal	
F230661	17
F230662	17
F230693	17
F231525-2	11
F231525-3	11
F231526-2	11
F231526-3	11
F231527-2	11
F231527-3	11
F231528-2	11
F231528-3	11
Diaphragm	
G300202	25
Dispenser Bracket	
F602722	13
Door	
F602431-1	17
F602837-1	17
F602842-1	17
Door Gasket	
F170106	17
F170106-1	17
F170123	17
F170123-1	17
F170124	17
F170124-1	17
Door Glass	
F290205P	17
F290207P	17
F290208P	17
Door Handle	
F150225	17
Door Handle Spacer	
F150227	17
Door Hinge	
F150224	17
Door Lock Assembly	
F631532-1	33
F631532-2	33
F631532-3	33
F631532-4	33
Door Lock Board	
F370432	5
Door Lock Lever	
F605381	33
Door Lock Pin	
F431231	33
Door Lock Pin Release Spring	
F310137	33
Door Lock Plate Subassembly	
F633084	33
Door Lock Spring	
F310125	17

Door Lock Torsion Spring	
F310110	33
Door Lock Wiring Harness	
F631986-1	33
F631986-2	33
Door Mount	
F150226	17
Door Switch	
F340200	33
Drain Connection Tee	
F150318	21
F150398	21
Drain Valve	
F380618	21
F380619	21
F380629	21
Drain Valve Motor	
F380932	21
F380933	21
F380943	21
F380944	21
F380972	21
Drain Valve Motor Cover	
F602761	21
Dual Fuse Holder	
F350312	5

E

Electrical Module Cover	
F234175	15
F634175	5

F

Fill Connector Manifold	
F150371	35
Filter	
F270405	27
F270406	27
Filter Assembly	
F270305	27
F270306	27
Flange Relay	
M412534	5
Flex Hose	
F200170	39
Flow Restrictor	
F380957	23
F380958	23
Frame Assembly	
F606178	19
F607003	19
F607004	19
F607005	19
F630232	19
Front Drain Hose	
F150312	21
F150400	21
Front Panel	
F634398	9
F634501-1	9
F634666*	9

F634668-*	9
F634682-*	9
F634683-*	9
F634764-*	9
F634765-*	9
F634816-*	9
F634817-*	9
F634836-*	9
F634837-*	9

Front Panel Kit	
F757404	9
F757405	9
F757406	9
F757408	9
F757410	9
F757413	9
F757414	9
F757415	9
F757418	9
F757419	9
F757422	9
F757423	9
F757484-01	9
F757484-02	9
F757484-05	9

Fuse	
F350115	5
F350117	5
F350138	5
F350146	5

Fuse Holder	
F350312	35

G

Gasket	
F270407	27
Ground Connector	
F140734	35, 37

H

Hinge	
F190203	13
Hinge Rod	
F602813-2	17
F602813-3	17
Hinge Shim	
F602679	17
Hose	
F150331	39
F150414	39
F200108	35, 37
F606816-1	35
Hose Filter Washer	
F270300	27

I

Inlet Hose	
F200116	27
F200164	27
F200165	27

F200166	27
Inner Front Panel Assembly	
F631685-1	11
F631687-1	11
F631688-1	11
F631689-1	11
F631690-1	11
F634462-1	11
F634505-1	11

Inner Front Panel Trim	
F610106	11
F610203	11
F610396	11

Input Power Block	
F140746	35, 37
F140747	35, 37

J

Junction Box Cover	
F602533	35, 37

K

Key	
F430801	29
F430802	29

L

Latch Arm	
F150229	17
Lockwasher	
F431113	17
Lower Brace	
F634800	9
F634801	9
F634802	9
F634803	9

M

Magnet	
F340703	17
Magnetic Switch	
F340702	11
Main Drive Shaft & Seal Kit	
F380918	21
Mechanical Interlock	
F330152	5
F330186	5
Micro Door Lock Switch	
F340923	33
Mixing Valve Mounting Plate	
F606595	35, 37
Motor	
F220110	31
F220111	31
F220111-H	31
F220120	31
F220120-H	31

F220124	31
F220124-H	31
F220125	31
F220128	31
F220128-H	31
F220130	31
F220320	31
F220321-H	31
F220322-H	31
F220325	31
F220325-H	31
F220326-H	31
F220327	31
F220354	31
F220387	31
F220387-H	31
F220388	31
F220388-H	31
F220396-H	31
F798728	31
Motor Pulley	
F280170	29
F280177	29
F280184	29
F280185	29
F280186	29
F280198	29
F280279	29
F280281	29
F280282	29
F280283	29
F280284	29
Motor Spring Clip	
F601515	29
Motor Support Rod	
F602844	29
F603059	29
F603897	29
Mounting Bracket Assembly	
F634318	5
F635319	5
Mounting Rail	
F610083	5

N

Nut	
F430215	11, 17, 19, 21, 33
F430218	19
F430225	33
F430231	13, 21, 33, 35, 37
F430232	17, 33, 35, 37
F430239	19
F430240	19
F431005	13
F431017	33
F431022	5, 17
F431041	17
Nylon Washer	
F431907	17

O

Output Relay Board	
F370433P	5

F370434P	5
Overflow Hose	
F150317	21
F150332	21
F150417	21

P

Pin	
F431222	17
Pin Door Lock Linkage	
F150455	33
Plate	
F603185	33
Plate Cover	
F602567	33
Push Button Rod	
F320300	17

R

Rear Drain Hose	
F150311	21
F150331	21
F150399	21
Rear Panel	
F602422	15
F603121	15
F603249	15
F606202	15
F630475	15
Repair Kit	
F380939	23
F380954	23
G581P3	25
Retainer Ring	
F310205	33
Rivet	
F431215	11, 13, 15
F431217	11

S

Screw	
F430100	29
F430103	21
F430174	5, 13, 15, 33, 35, 37
F430177	37
F430532	17
F430533	17
F430903	35, 37
F430906	17
F430910	21
F430916	7, 17
F430917	5, 11
F430925	11, 13, 33
F430927	21, 29
F430929	35, 37
F430938	35, 37
F430948	35, 37
F430956	9
F430976	17
F430977	33

F430982	33
F430983	33
F430986	9
F432293	9
Service Key	
F160562	13
F190805-1	13
Shell Band Assembly	
F602757	19
F603229	19
F603656	19
F631977	19
Shell Front Assembly	
F609270-1	19
F609271-1	19
F609272-1	19
F632006	19
Shell Seal Gasket	
F170152	19
Side Panel	
F603016	15
F603017	15
F603125	15
F603130	15
F606544	15
F607826	15
F630469	15
F634396-1	15
F634455-1	15
F634475-1	15
F634500-1	15
F634514-1	15
Soap Dispenser Bracket	
F602722	15
Soap Dispenser Clamp	
F602729	13
Soap Dispenser Cover	
F150305	13
F150305-1	13
Solenoid	
F300125	33
Spacer	
F430977	33
Splash Shield	
F320200	33
Standard Shell Assembly	
F606981	19
F634600	19
F634608	19
F634644	19
F634663	19
Standoff	
F180506	5
Stud	
F390300	13
Supply Dispenser	
F634377	35, 37
Supply Dispenser Hose	
F150309	39
Switch	
F340002	7

T

Tee	
F422817	39
Terminal	
F140768	5
Terminal Strip	
F140738	5
3-Way Mixing Valve	
F380794	23
F380795	23
F381719	25
F381729	25
Tinnerman Nut	
F430606	11
Top Brace	
F602620	13
F603014	13
F603227	13
F606239	13
F631247	13
Top Cover Latch Arm	
F602753	13
Top Cover Lock	
F190802	13
F190805	13
Top Cover Subassembly	
F603745	13
F603801	13
F605997	13
F606956	13
F631962	13
Top Cover Switch	
F340437	13
Transformer	
F360153	5
Trim	
F150452	9
F150452-1	9
Trunnion Kit	
F747000	19
F747001	19
F747002	19
F747004	19

V

Vacuum Breaker Assembly	
F603031	35, 37
Vacuum Breaker Hose	
F150321	35, 37, 39
F150340	35, 37, 39
F150372	35, 37, 39
Valve Assembly	
F634857	25
F634883	25
Valve Body	
F380920	21
Valve Panel Subassembly	
F603393	13
F604117	13
F604118	13
F631957	13
F633494-1	13

F633494-2.....	13
F633494-3.....	13
F633494-4.....	13
Valve Screen	
F270200.....	23
Vent	
F422517.....	39

W

Washer	
F200500.....	27
F430301.....	19
F430303.....	19
F430311.....	7
F430317.....	11, 19
F430322.....	35, 37
F430325.....	29
F431100.....	33
F431105.....	13
F431113.....	5
F431115.....	29
F431123.....	33
F431126.....	29
F431128.....	19
F431131.....	19
F431901.....	33
F431902.....	33
Water Level Switch	
F340311.....	5
F340312.....	5
F340321.....	5
F340325.....	5

Y

"Y" Connector	
F422808.....	37