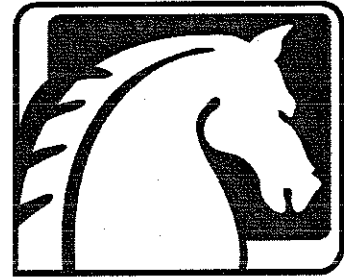


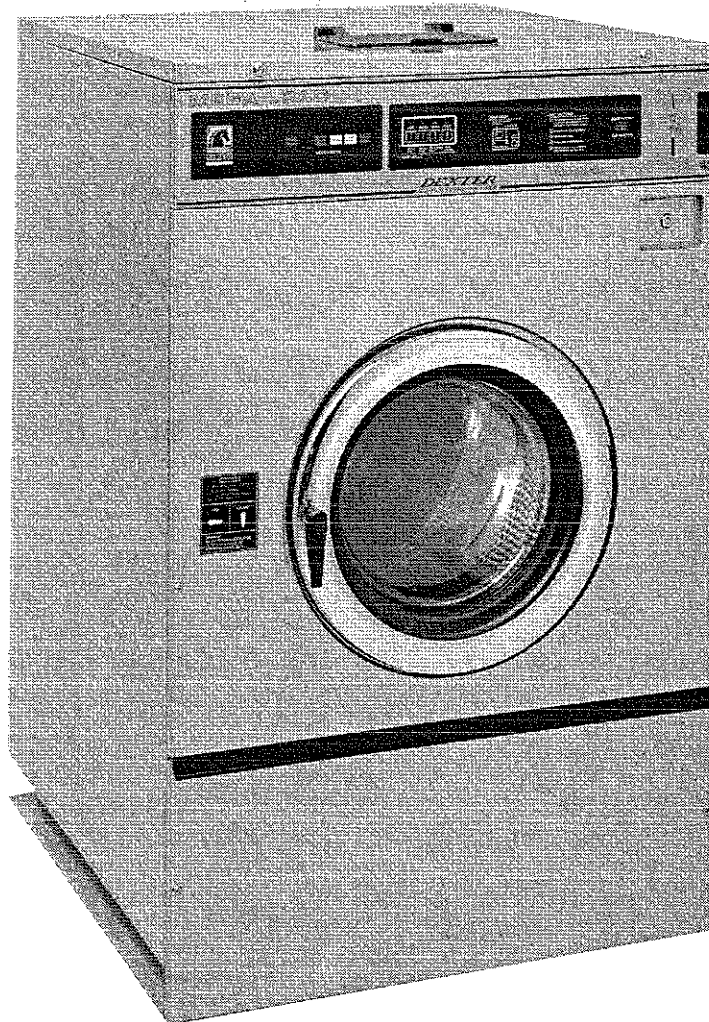
THE  
DEXTER  
COMPANY



## 55 LB. COIN OPERATED WASHERS

Thoroughbred 900  
WCN55AEK

### Service Procedures and Parts Data Thoroughbred 900



Fairfield, Iowa 52556  
Part No. 8533-033-001  
8/01

Telephone 641-472-5131  
Fax 641-472-6336

# WARNING

THESE WASHERS ARE EQUIPPED WITH DEVICES AND FEATURES RELATING TO THEIR SAFE OPERATION. TO AVOID INJURY OR ELECTRICAL SHOCK, DO NOT PERFORM ANY SERVICE, UNLESS QUALIFIED TO DO SO.

A machine should not be allowed to operate if any of the following occur:

- Excessively high water level.
- Machine is not connected to a properly grounded circuit.
- Loading door does not remain securely locked during the entire cycle.
- Vibration or shaking from an inadequate mounting or foundation.

## WARNING - FOR SAFETY

1. Always shut off power and water supply and wait 2 minutes before servicing to allow capacitors in variable frequency drive to discharge
2. Do not overload the washer.
3. Do not attempt to open door if cylinder is in motion or contains water.
4. Do not mechanically force or override door lock in any way.
5. Do not bypass any safety devices of this washer.
6. Do not use volatile or flammable substances in or near the washer.
7. Keep all panels in place. They protect against shock and injury and add rigidity to the washer.

# Table of Contents

## SECTION 1

Specifications .....	page 6-8
Cycle Times .....	page 6
Water Usage .....	page 8
Water Temperatures .....	page 8

## SECTION 2

Installation & Operation .....	page 9-15
Foundation Requirements .....	page 9
Plumbing .....	page 9
Electrical .....	page 10
Controls Transformer .....	page 10
Mounting Dimensions .....	page 11
Concrete Pedestal .....	page 12
Final Check out .....	page 13
Setting the Accumulator .....	page 13
Setting the Operating Mode .....	page 14
Connections for Injection Systems and Rinse Conversions .....	page 15

## SECTION 3

Operating Instructions & Detergent Chart .....	page 16
--	---------

## SECTION 4

Service Procedures .....	page 18-29
Top Panel Removal .....	page 18
Detergent Dispenser .....	page 18
Vacuum Breaker .....	page 18
Water Valves .....	page 18
Circuit Breaker .....	page 18
Control Mounting Trough .....	page 19
Coin Accumulator Transformer & Board .....	page 19
Drop Coin Acceptor .....	page 19-20

Reversing Timer .....	page 19
R1 Run Relay .....	page 21
R2 Spin Motor Relay (intermediate extract) .....	page 21
R3 Extract Relay (high speed extract) .....	page 21
Program Timer .....	page 21
Controls Transformer .....	page 21
Pressure Switch .....	page 21
Power Connection Terminal Block .....	page 21
Cycle Indicator Lights .....	page 21
Temperature Selector Switch .....	page 22
Add-Bleach Light .....	page 22
Lower Service Panel .....	page 22
Drain Valve .....	page 22
Front Panel .....	page 22
Masking Ring (door lock cover) .....	page 22
Door Lock Assembly .....	page 23-25
Door Locking Solenoid .....	page 26
Thermoactuators .....	page 26
Loading Door .....	page 26
Loading Door Hinge .....	page 26
Back Panel .....	page 27
Drive Belt .....	page 27
Drive Motor .....	page 27
Control Panel Name Plate .....	page 27
Cylinder (basket).....	page 28-29
Bolt Torque Chart .....	page 30
Water Seals .....	page 30
Bearing Housing Assembly .....	page 30
Outer Tub.....	page 30

## SECTION 5

Wiring Schematic and Trouble Shooting .....	page 31-58
Troubleshooting .....	page 31-36
Delta drive troubleshooting .....	page 37-38

Delta drive fault descriptions .....	page 39-40
Drive Status .....	pages 41-51
Start Circuit .....	page 52
Fill Circuit-Warm .....	page 53
Wash Circuit .....	page 54
Drain, Rinse 1 & 2, & Final Rinse Circuit .....	page 54
Intermediate Extract .....	page 55
Final Extract Circuit .....	page 55
Thermoactuator and Shake Out Circuit .....	page 56
End of Cycle Circuit .....	page 56
Schematic .....	page 57
Diagram .....	page 58

## SECTION 6

Parts Data .....	page 59-80
Accessories .....	page 59
Cabinet and Front Panel Group .....	page 60-61
Rear View .....	page 62-63
Chassis and Drain Group .....	page 64-65
Cylinder, Water Seals & Bearing Housing Group .....	page 66-67
Door Lock Group .....	page 68-69
Loading Door Group .....	page 70-71
Control Panel Group .....	page 72
Water Inlet Group .....	page 73
Electrical Components - Top Compartment .....	page 74-75
Coin Handling Group .....	page 76-77
Water Inlet Valve Breakdown .....	page 78
Drain Valve Group .....	page 79
Terminal Blocks & Labels .....	page 80
Wiring Harness Group .....	page 80

## SECTION 7

Maintenance .....	page 81
-------------------	---------

# Section 1

## Specifications

### Thoroughbred 900 Coin Washer

<b>Model</b>	<b>Voltage</b>
WCN55AEK	208-240 volts, 60 Hz, Single Phase/Three Phase

### Cycle Times

	<b>Prewash &amp; 3 Rinses</b>	<b>Prewash &amp; 2 Rinses</b>	<b>No Prewash &amp; 3 Rinses</b>	<b>No Prewash &amp; 2 Rinses</b>
<b>Prewash</b>	4 min.	4 min.	Not used	Not used
<b>Drain</b>	40 sec.	40 sec.	Not used	Not used
<b>Wash</b>	8 min.	8 min.	8 min.	8 min.
<b>Drain</b>	40 sec.	40 sec.	40 sec.	40 sec.
<b>Rinse 1</b>	3 min. 45 sec.	Not used	3 min. 45 sec.	Not used
<b>Drain</b>	40 sec.	Not used	40 sec.	Not used
<b>Rinse 2</b>	3 min. 45 sec.	3 min. 45 sec.	3 min. 45 sec.	3 min. 45 sec.
<b>Drain</b>	40 sec.	40 sec.	40 sec.	40 sec.
<b>Int. Spin</b>	50 sec.	50 sec.	50 sec.	50 sec.
<b>Rinse 3</b>	3 min. 45 sec.	3 min. 45 sec.	3 min. 45 sec.	3 min. 45 sec.
<b>Drain</b>	40 sec.	40 sec.	40 sec.	40 sec.
<b>Extract</b>	4 min.	4 min.	4 min.	4 min.
<b>Tumble</b>	16 sec.	16 sec.	16 sec.	16 sec.
<b>Total *</b>	32 min.	27.5 min.	27 min.	23 min.

\* Cycle times are approximate and do not include fill time.

# Specifications

<b>Capacity</b>	55lbs.
<b>Dimensions</b>	
Cylinder Depth	22"
Cylinder Diameter	30"
Cylinder Volume (cubic feet)	9.0
Door Opening	15 1/4"
Door Height (floor to bottom of door)	18 3/8"
Overall Height	54"
Cabinet Width	34 3/8"
Overall Depth	38 3/4"
Drain Diameter (O.D.)	3"
Drain Height (floor to center of outlet)	7 1/2"
Recommended Clearance Between Machines (minimum)	1/2"
Necessary Service Clearance Behind Machine	24"
<b>Cylinder RPM</b>	
Tumble Speed	43
Extract Speed	485
Extract Speed G-Force	100
Cylinder Direction in Extract	counter clockwise
<b>Motor H.P.</b>	
Wash (single phase)	3
(three phase)	3
Extract (single phase)	3
(three phase)	3
<b>Amperage (average measured on L1)</b>	
Wash(three phase)	3.8
Wash (single phase)	6.8
Extract (three phase)	3.1
Extract (single phase)	5.0
<b>Running Amps (maximum)</b>	
Single Phase	10.0
Three Phase	5.4
<b>Circuit Breaker (amps)</b>	
Three Phase	15
Single Phase	15
Built-in Controls Circuit Breaker	yes
Built-in Motor Protection	yes

<b>Voltage 60 Hz.</b>	
Three Phase	208-240
Single Phase	208-240
<b>Service</b>	
Three Phase	3 wire plus ground
Single Phase	2 wire plus ground
<b>Wire Size (min.)</b>	
Three Phase	12
Single Phase	12
<b>Water</b>	
Average Water Usage	
Normal Cycle with Full Load	69 gal.
Maximum Hot Water Use--	
Hot cycle with Full Load	31 gal.
Recommended Hot Water (degrees)	140
Water Pressure (min/max)	30-120psi
Water Inlet Size (hose thread)	3/4"
Water Flow Rate (gallons/minute)	9
<b>Wash Cycle</b>	
Normal Wash-Excluding Fill Time	22min45sec
Wash Temperatures	hot, warm & cold
Rinse Temperatures	cold-std. warm-opt.
<b>Mounting Hole Dimensions</b>	
Left to Right	27 3/4"
Front of Cabinet to First Hole	2 3/4"
First Hole to Second Hole	23"
Second Hole to Third Hole	11"
Mounting Bolt Diameter	3/4"
Hole Diameter in Base	1"
Concrete Thickness (min.)	8"
Recommended Mounting Height	4"
<b>Weight</b>	
Shipping (lbs.)	1075
Net (lbs.)	1025

## Water Usage

	Wash 2 Rinses	Prewash 2 Rinses	Wash 3 Rinses	Prewash 3 Rinses
<b>Prewash</b>	Not used	29.8 gal.	Not used	29.8 gal.
<b>Wash</b>	31.3 gal.	14.6 gal.	31.3 gal.	14.6 gal.
<b>Rinse 1</b>	Not used	Not used	14.2 gal.	14.2 gal.
<b>Rinse 2</b>	14.8 gal.	14.8 gal.	14.8 gal.	14.8 gal.
<b>Int. Spin</b>				
<b>Rinse 3</b>	23.2 gal.	23.2 gal.	23.2 gal.	23.2 gal.
<b>Total</b>	69.3 gal.	82.4 gal.	83.5 gal.	96.6 gal.

## Water Temperatures

	Heavy Duty	Normal	Perm Press	Delicates
<b>Prewash</b>	Hot	Warm	Warm	Cold
<b>Wash</b>	Hot	Warm	Warm	Cold
<b>Rinse 1</b>	Cold	Cold	Cold	Cold
<b>Rinse 2</b>	Cold	Cold	Cold	Cold
<b>Rinse 3</b>	Cold	Cold	Cold	Cold



# Section 2

## Installation & Operation

All washers must be installed in accordance with all local, state and national building, electrical, and plumbing codes in effect in the area.

### Foundation Requirements

The washer must be securely bolted to a substantial concrete floor, or mounted upon a suitable base which is in turn securely bolted to a substantial concrete floor. Care must be stressed with all foundation work to insure a stable unit, eliminating vibration. All installations must be made on sound concrete floors 8" or thicker.

### Mounting

A concrete pad or steel base which elevates the machine 4 inches above the floor level is recommended to provide easy access to the loading door. Allow a minimum of 24" of clearance behind the rear of the machine for service as is shown. Six bolts are required to mount the washer to the steel base or concrete pad.

### Mounting Holes

The following pages illustrate the mounting dimensions for the machine and also show a typical concrete pad arrangement.

**Note: Mounting bolts should be checked frequently to insure that they remain tight. The machine should be checked with a spinning load to be sure there is no unusual vibration or movement between the machine and the base or floor.**

### Plumbing

Water supply hoses are furnished with each machine. The threaded connections on the hoses are standard garden hose type thread. Separate hot and cold water lines with shut off valves or faucets for inlet hose connections must be provided, maintaining 30 to 120 p.s.i. water flow pressure. A hot water recovery rate of approximately 70 gallons per hour is required with normal wash and cold rinses. A hot water temperature of 140 degrees Fahrenheit is recommended for best washing results.

### Drain

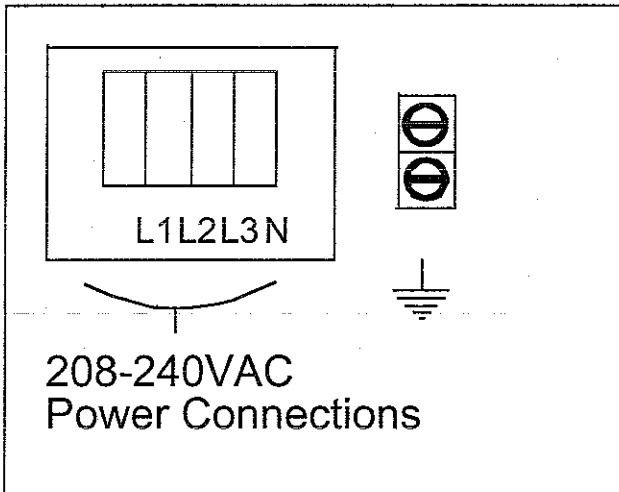
The drain outlet tube at the rear of the machine is 3" in outside diameter. A flexible hose (Pt. No. 9242-417-003) is available to extend the drain system. Adequate fall must be maintained for proper drainage.

### Protective Film

The machine may have protective adhesive film on the front escutcheon area and the front and side stainless steel panels. The film may be peeled off before putting the machine into service.

## Electrical

Dexter WCN55 series washers are intended to be permanently installed appliances. The machines should be connected to an individual branch circuit not shared by lighting or other equipment. The electrical connection should be sheathed in water proof flexible conduit, or equivalent, with conductors of the proper size and insulation (suggested size below). A power cord is not provided. The following diagram shows the proper power connections to the rear terminal block for both 1 and 3 phase machines. Wiring should be performed by a qualified person.



Electrical power connections are made to the terminal block located at the upper right-rear corner of the washer (viewed from the front). The terminal block is accessed by removing the cover.

**1 Phase, 208-240 volts, 60 Hz.**  
connect L1, L2, and ground

**3 Phase, 208-240 volts, 60 Hz.**  
connect L1, L2, L3 and ground  
(high leg must go on L3)

**Suggested Minimum Wire Size 12 Ga.**

**Fusing Requirements: Dual element time delay fuse or equivalent breaker of amperage specified below.**

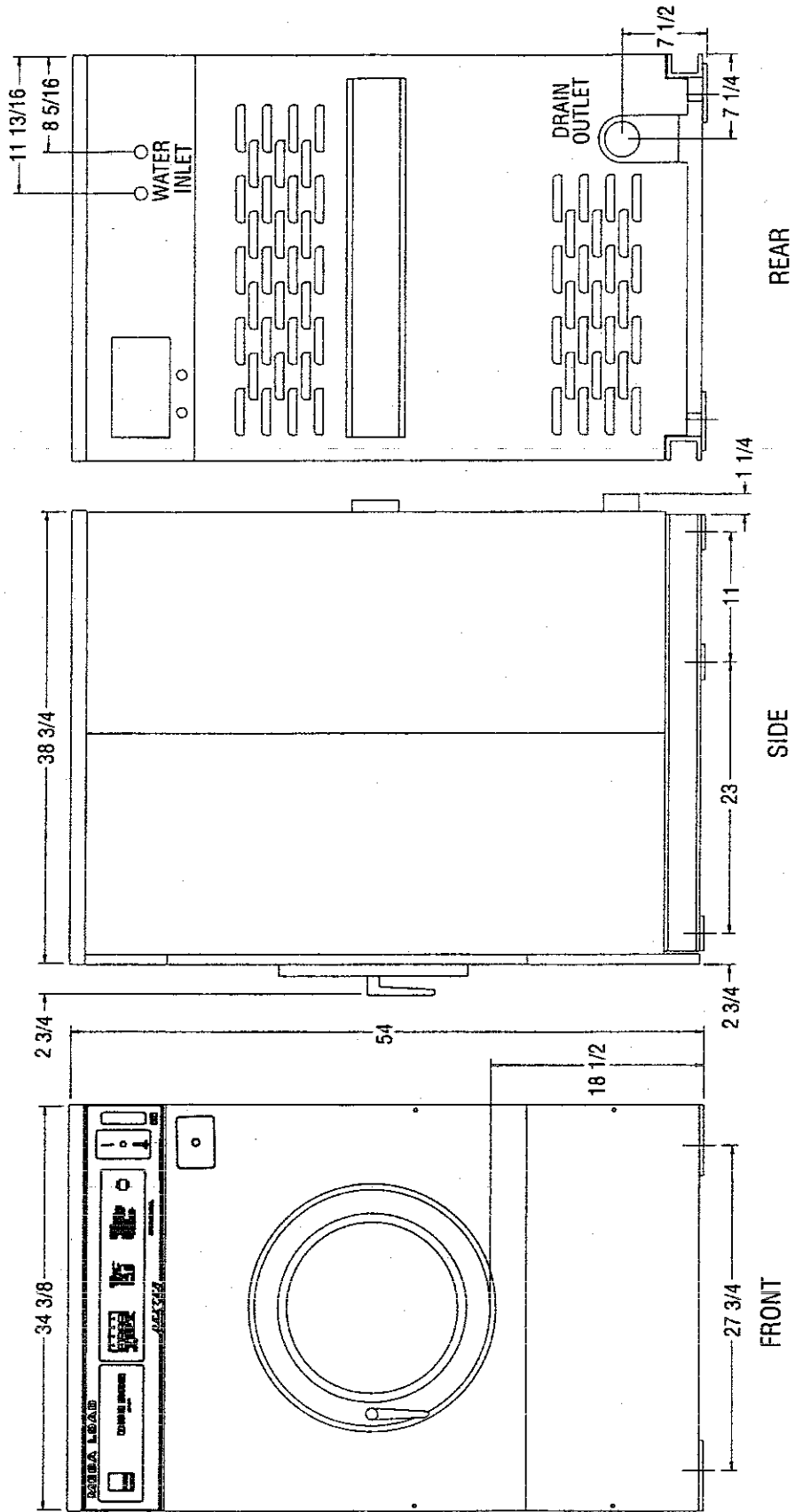
1 Phase/ 3 Phase      15 amp

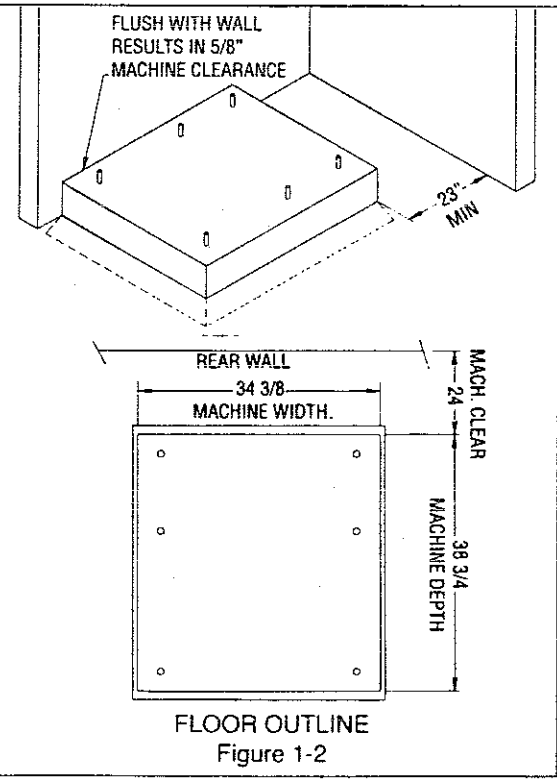
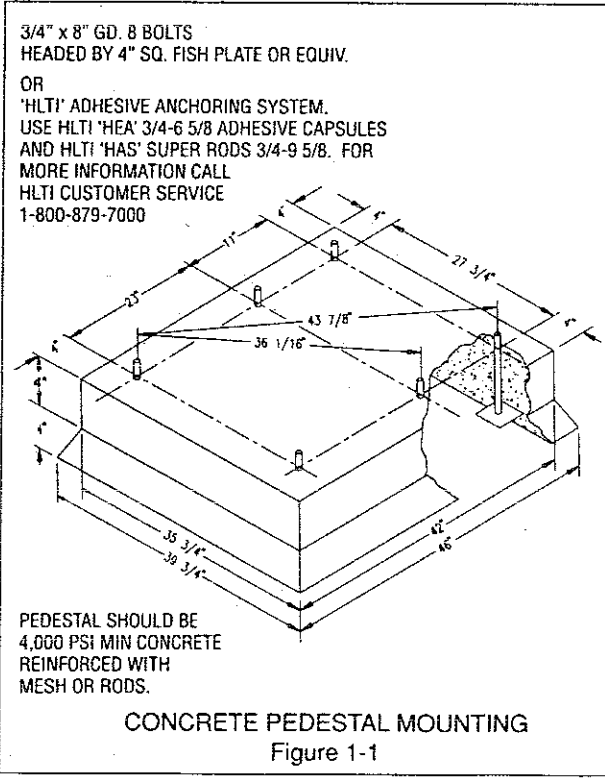
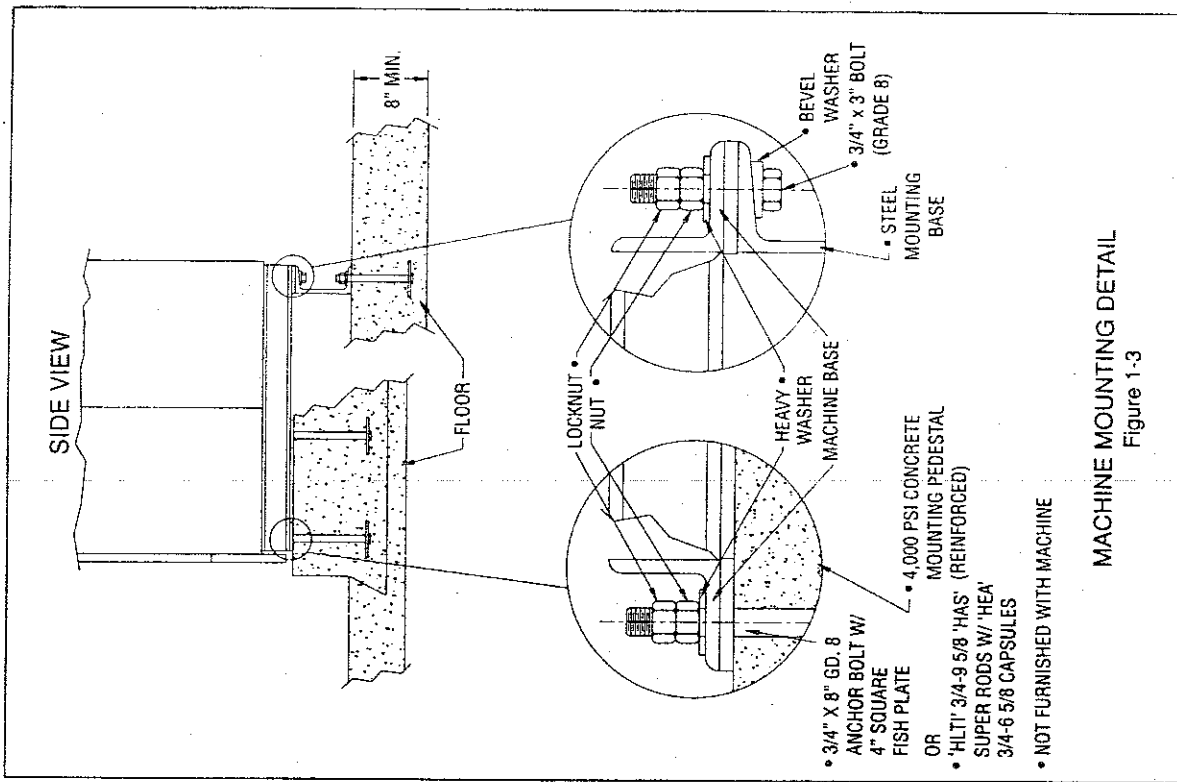
**Always disconnect electrical power to the machine before performing any adjustments or service work.**

## Controls Transformer

This transformer is mounted at the back of the control trough and steps a range of 208 to 240 volts down to 115 volts for the controls. There are two terminals on the controls transformer for incoming power. One terminal is for 208 to 220 volts and the other is for 221 to 240 volts.

# 900 SERIES COMMERCIAL WASHER MOUNTING DIMENSIONS





## Final Check out

Always disconnect electrical power to the machine before opening the top. Avoid contact with capacitor or other electrical terminals.

Open the top of the machine as follows:

- A. Remove the four screws that hold the dispenser to the top panel.
- B. Unlock the top panel, slide to the rear to release and remove the top panel from the machine.

### Setting the Accumulator

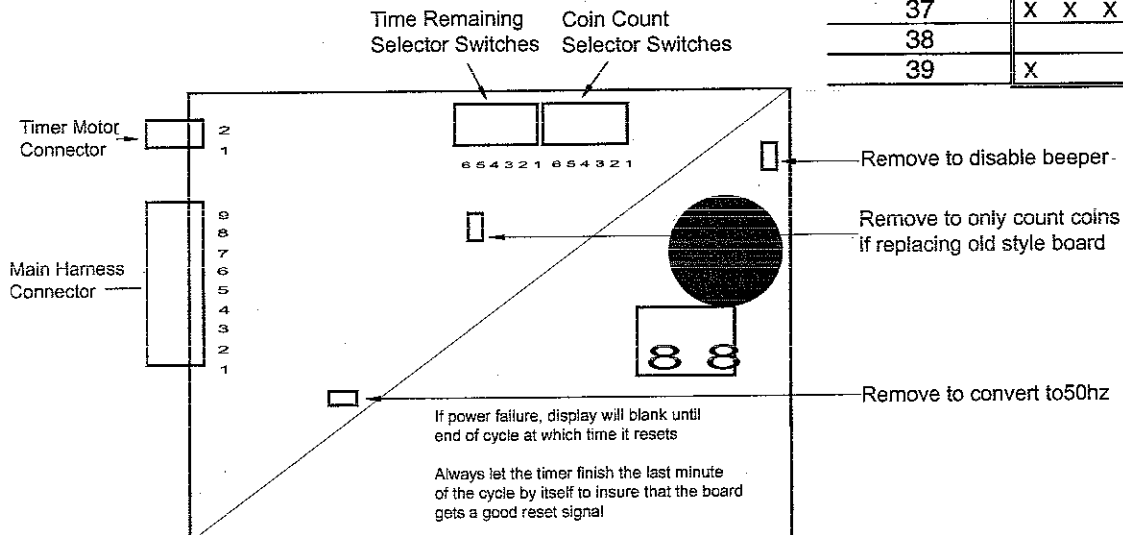
Always disconnect electrical power to the machine before setting the accumulator. Avoid contact with capacitor or other electrical terminals.

The accumulator board contains the digital coin count and time remaining display and is attached to the front of the machine. The **amount to start** is set by depressing the 6 small switches on the top edge of the accumulator in the correct combination for the desired number of coins. The **time remaining** is set by depressing the other six small switches on the top edge of the accumulator in the correct combination for the desired cycle time. (See chart for correct combinations) The switch numbers and names are printed on the clear cover over the coin accumulator circuit board. The switches are actuated by pushing the switch operator toward the back of the machine. As the switches are very small, a golf tee or some other nonmetallic tool is desirable for this process.

**Note:** For use in Canada, the coin acceptor magnet must be removed. See drop coin acceptor in Service Procedures Section for location of magnet.

### Coin Accumulator Chart

Number of Coins or Minutes	Switch Number					
	1	2	3	4	5	6
1	X					
2		X				
3	X	X				
4			X			
5	X		X			
6		X	X			
7	X	X	X			
8				X		
9	X			X		
10					X	
11	X				X	
12		X			X	
13	X	X			X	
14			X		X	
15	X		X		X	
16		X	X		X	
17	X	X	X		X	
18				X	X	
19	X			X	X	
20						X
21	X					X
22		X				X
23	X	X				X
24			X			X
25	X		X			X
26		X	X			X
27	X	X	X			X
28				X		X
29	X			X		X
30					X	X
31	X				X	X
32		X			X	X
33	X	X			X	X
34			X		X	X
35	X		X		X	X
36		X	X		X	X
37	X	X	X		X	X
38				X	X	X
39	X			X	X	X



## Setting the Operating Mode (Program length)

See the Cycle Time Chart in Section 1 for the four available Cycle Times.

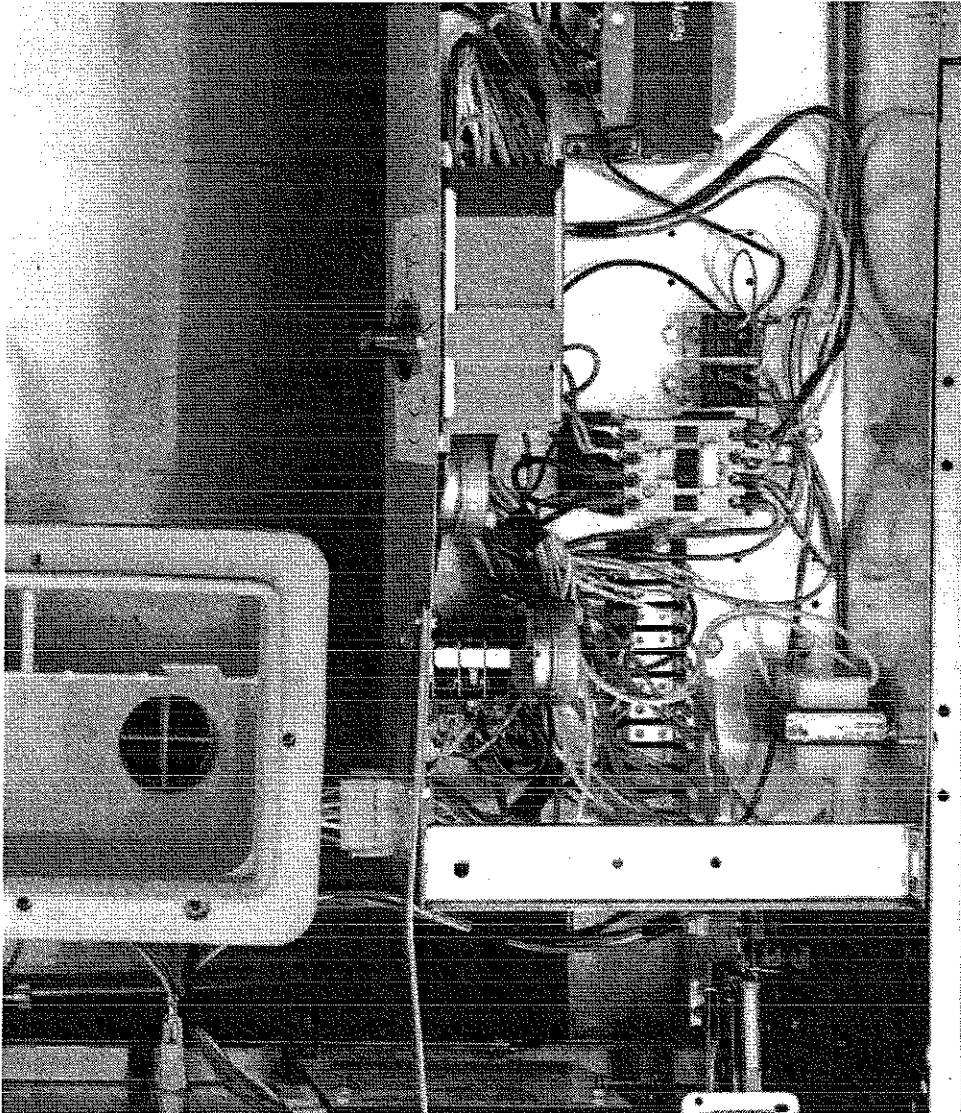
The operating mode can be selected by moving one jumper wire on the 12 position terminal block. Machines are shipped with the wire connecting terminal 4 to 7 giving no prewash and 2 rinses. Relocating the end of the orange/white wire with the plastic housing from position 7 gives these selections:

- Moving to #4 gives prewash and 3 rinses
- Moving to #5 gives prewash and 2 rinses
- Moving to #6 gives no prewash and 3 rinses
- Leaving on #7 gives no prewash and 2 rinses

**After changing the operating mode (program length), refer to Setting the Accumulator on the previous page to reset the cycle time remaining for the correct length of time for the new cycle.**

Close top, replace screws in dispenser, lock top and reconnect power.

**After all mounting, plumbing and electrical work is completed, the washer should be run through a cycle and checked for water leaks and proper functioning.**



# Connections for Injection Systems and Rinse Conversions

## Connections for Injection Systems

Signals for the connection of chemical injector systems are available at the connection points listed below. These points will give 120VAC signals. The locations listed as TB-# are terminal block numbers for the large terminal block at the front of the control trough.

DESCRIPTION	TERMINAL LOCATION
Prewash	TB-12
Bleach	TB-2
Wash	This connection maybe made at the wash light at the front of the machine. The wire color to piggyback on is yellow/orange.
Rinse	This connection maybe made at the rinse light at the front of the machine. The wire color to piggyback on is yellow/blue. Be sure not to use the final
Final Rinse	rinse light. TB-8

## Connection for Warm Rinses

As shipped from the factory all rinses are cold. Rinses can be converted to warm by moving the brown/orange wire on TB-11 to TB-9 (TB-# relates to a terminal number on the large terminal block located in the electrical control trough). **Disconnect electrical power before moving the wire.**

# Section 3

## Operating Instructions

### Accumulator

Prior to operation, the coin accumulator should be set for both the number of coins to start and the number of minutes in the cycle. (see Setting the Accumulator)

### Starting the Washer

A. Pour low-sudsing powdered detergent in the amount shown below into the detergent dispenser on top of the machine. Rinse conditioners may also be added to the dispenser. The correct location is shown on the dispenser lid.



B. Load the clothes loosely in the cylinder and latch the door securely. Be sure clothing does not get caught between the door gasket and tub front when closing the door.

**NOTE: To close the door the handle must be in the horizontal position . After moving the door to the closed position, the handle must be turned down to the vertical position to latch the door for machine operation.**

- C. Using the buttons on the front, select the wash cycle having the desired temperature.
- D. Insert the preset number of coins as shown in the coin display to start the machine. The washer will automatically start, the red "on" light will glow and the cycle time will count down. The clothes door will lock and remain locked until the end of the cycle.
- E. At the correct time in the cycle the green "ADD BLEACH" light will come on indicating the time and location for adding bleach if desired.

### End of Cycle

When the cycle is completed, the end of cycle beeper will sound and the "on" light will go off. The loading door can now be opened by turning the door handle to the indicated position and pulling. Leave the clothes door open when the machine is not in use. Also, at the end of cycle the coin count display will reset to the original number of coins required to start.





# Section 4

## Service Procedures

Before performing any service work, remove electrical power from the machine.  
Always replace panels before putting machine into service.

### Top Panel Removal

- A. Remove 4 screws that hold detergent dispenser to top panel.
- B. Unlock top panel lock.
- C. Raise top panel, slide to the rear to release from back clips and lift off.

### Detergent Dispenser

Remove top panel to access dispenser. (see Removing Top Panel)

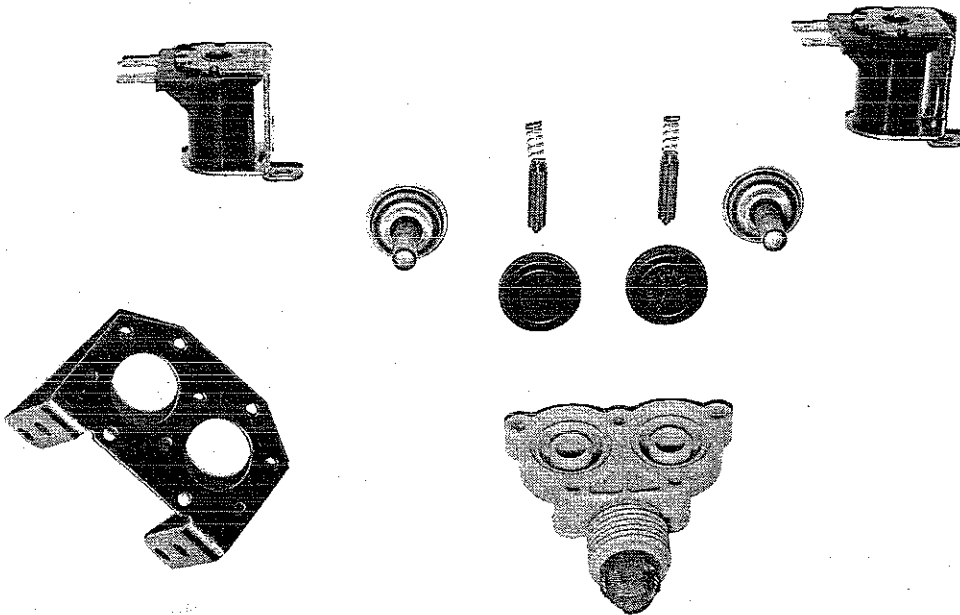
Detergent is flushed from the front of the compartment and fabric softener is flushed from the back. There will be a small amount of water left in the fabric softener compartment after each use. This is normal.

### Vacuum Breaker

In the left rear of the cabinet is the vacuum breaker. It guides the water to the tub and dispenser and prevents a back flow of water.

### Water Valves

Remove top panel to access water valves. (see Removing Top Panel) The two dual outlet water valves are mounted to the rear channel with two screws each. Always check inlet screens to be sure that they are clean. Disassembly requires the removal of two solenoid screws and three valve body screws. Below the solenoid coil is a solenoid guide, armature, armature spring and diaphragm. All valve parts are available individually or as a complete unit.



## **Circuit Breaker**

The circuit breaker mounts to the rear channel. It carries all of the controls in the machine but does not include the motor. To reset the circuit breaker just push in the button.

## **Control Mounting Trough**

Remove top panel to access control trough. (see Removing Top Panel) It sets on the right side of the machine and holds many of the controls.

## **Coin Accumulator Transformer**

This transformer powers the coin accumulator board and is mounted on the right side of the control trough. It steps control voltage down to a 12VAC output. It is held in place with two screws.

## **Coin Accumulator Board**

This board displays the number of coins to start the washer, counts down the number of coins as they are added and with the preset coin amount satisfied, the coin accumulator closes a circuit sending control voltage to the timer on the orange with a white striped wire and starts the washer. The display will go blank for a few seconds and then count down the time remaining in the cycle. At the end of the cycle, the beeper will sound for 3 seconds and the timer closes the end of cycle cam providing control voltage on the white/yellow wire to the coin accumulator board. This signal from the timer resets the accumulator board so it is ready to count coins and the display goes back to the original amount of coins needed to start the washer. 12VAC power for the coin accumulator is supplied by the coin accumulator transformer discussed above. The board is retained by three nuts.

## **Drop Coin Acceptor**

The drop style coin acceptor contains a coin switch that is actuated by each good coin that is accepted.

### **Removal**

The coin acceptor is removed by loosening the two Torx T-10 machine screws on the right side and by removing completely the two Torx T-10 machine screws on the left side (#T-10 Torx driver, Dexter Pt.No. 8545-051-003). There are locking nuts on the back side that will have to be held. Needle-nose pliers work well for this. Sliding the acceptor to the left will remove it from the slots in the front panel. This gives access to the coin switch and acceptor for adjustments.

### **Coin Thickness Adjustment (see diagram)**

On the right side of the acceptor there is a coin thickness adjusting screw "A" with a locking nut. To allow for different thickness coins the screw can be turned in to accept thicker coins and turned out to reject thicker coins. Start with a quarter of a turn on this screw and be sure to retighten the lock nut after adjustment.

### **Coin Height Adjustment (see diagram)**

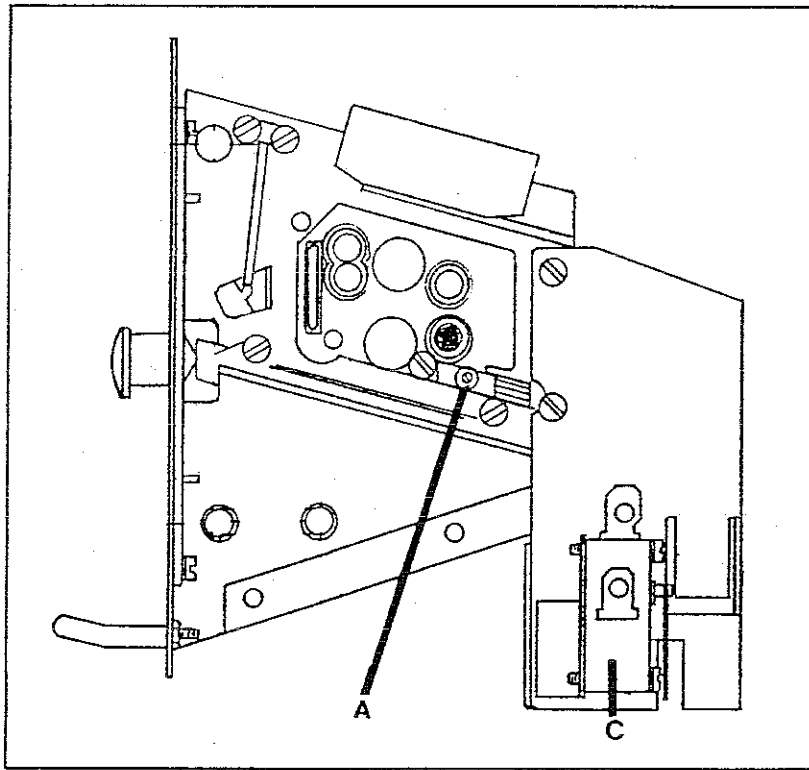
On the left side of the acceptor is a coin height adjusting bar "B". This bar is adjusted by loosening the two mounting screws and moving both ends of the bar up or down equal amounts. The bar should be raised as high as possible while still accepting the correct coins. If it is raised up too high, the good coins will be rejected.

### **Coin Switch Adjustment (see diagram)**

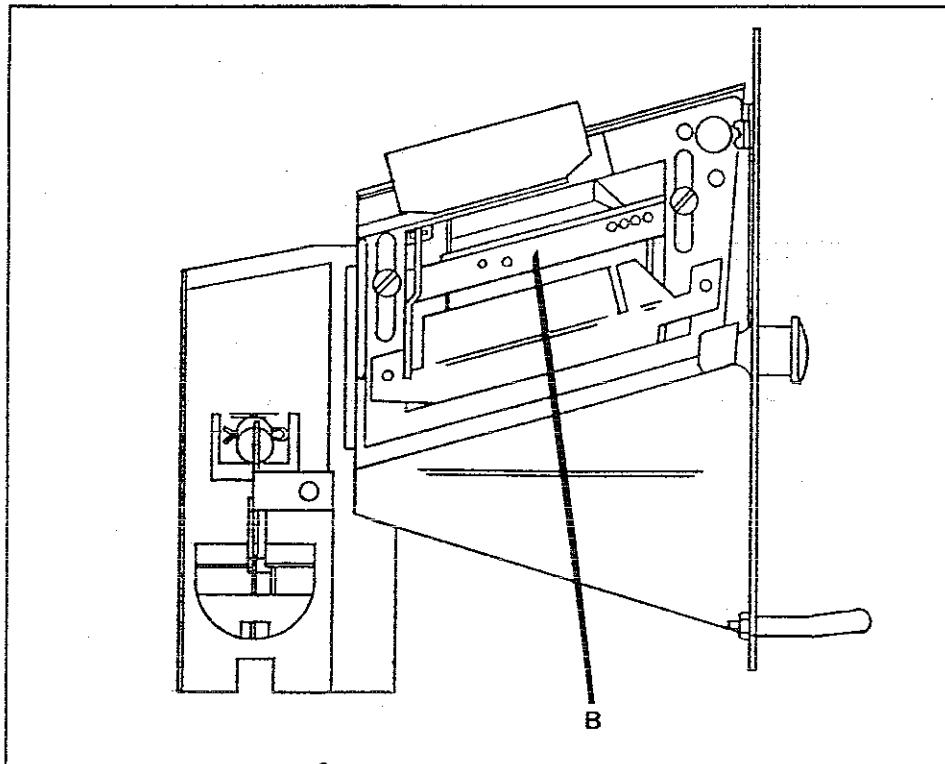
The normally open coin switch "C" should click (close) soon after the coin hits the operator wire. However, there must be enough travel to allow the switch to reset (open) once the coin has passed. Adjustment should be made by bending the wire very close to its attachment point.

## **Reversing Timer**

The reversing timer operates the variable frequency drive directly in wash and operates the spin relay for spin. It is mounted on the left side of the control trough with two screws. It has three cam operated switches. Two switches operate the wash cycle by alternately engaging and sending a 24VDC signal to the FW and RV terminals of the variable frequency drive to tumble counter clockwise for 19 seconds, stop for 3 seconds, reverse direction and tumble clockwise for 19 seconds. The third switch engages the spin relay for the intermediate and high speed spin portions of the cycle.



COIN ACCEPTOR - right side



COIN ACCEPTOR - left side

## Motor Relays

These relays are located in the center of the control trough. The front relay is for intermediate spin. The middle relay is for high speed extract. The back one is the run relay.

### R1 Run Relay

The R1 Run Relay is a small relay that is mounted directly behind the R3 extract relay. The 120VAC coil on the Run Relay is energized any time that the timer is in the run position and the door is locked. When energized, the Run Relay provides 24VDC to the reversing timer for wash and to the R2 intermediate extract relay for spin.

### R2 Spin Motor Relay (Intermediate Extract Relay)

The R2 Spin Motor Relay is the large relay that mounts in the center of the control trough. The 120VAC coil on the R2 Relay is energized any time that the timer is in the spin position. 24VDC is provided from the +24 terminal of the Variable Frequency Drive through the R1 Run Relay to the R2 Relay. When energized, the R2 Relay provides 24VDC to terminals MI2 & MI3 on the Drive and the washer spins at intermediate speed. The relay is removed by prying out on the mounting tab at the bottom of the relay with a straight blade screwdriver.

### R3 Extract Relay (High Speed Extract Relay)

The R3 Extract Relay is a small relay that is mounted directly behind the large R2 spin motor relay. The Main Timer provides 120VAC to the R3 Extract Relay coil. When this relay closes it provides 24VDC to the LI2 terminal on the Variable Frequency Drive. This relay combined with the R2 Spin Motor Relay powers all 3 terminals M11, MI2 & MI3 on the Variable Frequency Drive for high spin.

## Program Timer

This timer is located on the left side of the control trough directly behind the reversing timer and is held in place with two screws. It controls most machine functions. There are two drive motors on the program timer. The one towards the front of the machine advances the timer at the beginning of the cycle. The timer motor towards the rear drives the timer throughout the cycle. These two motors can be replaced individually. The program timer has a black knob that allows the timer to be manually turned to any portion of the cycle for diagnostic purposes.

## Controls Transformer

This transformer is mounted at the back of the control trough and steps a range of 208 to 240 volts down to 115 volts for the controls. There are two terminals on the controls transformer for incoming power. One terminal is for 208 to 220 volts and the other is for 221 to 240 volts.

**Note: All 60 Hz. 55lb. washers have a controls transformer. Always check the incoming voltage and use the appropriate transformer terminal when installing these washers.**

## Pressure Switch

The pressure switch sets the water level in the washer and is located in the left rear corner of the control trough. As the water level rises, it compresses the air in the pressure switch hose. When the washer reaches the desired water level, the compressed air in the pressure switch hose opens the contacts in the switch, shutting off the water. When at the empty level, the pressure switch contacts are closed allowing the machine to either spin or fill with water. With no load, the water level should be approximately 1/2" up from the bottom of the door glass. The pressure switch is sealed and is not adjustable.

## Power Connection Terminal Block

This terminal block sets in the right rear corner of the washer and is accessed from the back. Incoming power to the washer should connect here. (see Electrical under Installation and Operation Section for exact connections)

## Cycle Indicator Lights

The 120VAC indicator lights are mounted to the back of the control panel and are held in place with two tabs. They are removed by squeezing the tabs with a screw driver. The lights are replaced as a complete unit.

## Temperature Selector Switch

The push-button temperature selector switch is mounted in the center of the control panel and is held in place with two nuts. It allows the selection of hot, warm or cold water temperatures.

**Note: Do not over tighten on reinstallation as the switch can be damaged.**

## Add-Bleach Light

This 120VAC light indicates to the user the correct time to add bleach. It is removed by squeezing two mounting clips.

## Lower Service Panel Removal

Remove 2 screws and pull forward to disengage from the locator studs.

## Drain Valve

The drain valve is a ball type and is powered closed by the drain valve motor. It is mounted under the washer tub on the left side. It is spring loaded open. If power is interrupted to the washer, the motor releases the sealing ball, allowing the drive spring to open the valve. With the valve open, all water in the washer will drain out.

## Service

For access to drain valve, remove lower service panel.

## Cleaning

- A. Loosen the clamp on the tub hose at the drain valve end and remove the hose from the drain valve.
- B. Loosen the drain hose clamp on the back of the drain valve.
- C. Remove two drain valve mounting bracket screws from the frame of the washer.
- D. Remove the drain valve and bracket assembly.
- E. Unplug the wiring after the drain valve is removed from the washer.

## Front Panel Removal

- A. Remove 2 screws between front panel top and front channel (located behind control panel).
- B. Remove the two screws in the middle of the front panel.
- C. Pull panel out at the bottom to about a 45 degree angle to detach the top lip and remove.

## Masking Ring (door lock cover) Removal

- A. Remove front panel.
- B. Remove nuts that retain masking ring.
- C. Move it to the left and off.

## Door Lock Assembly

After removing the front panel and trim ring, the door lock assembly can now be accessed.

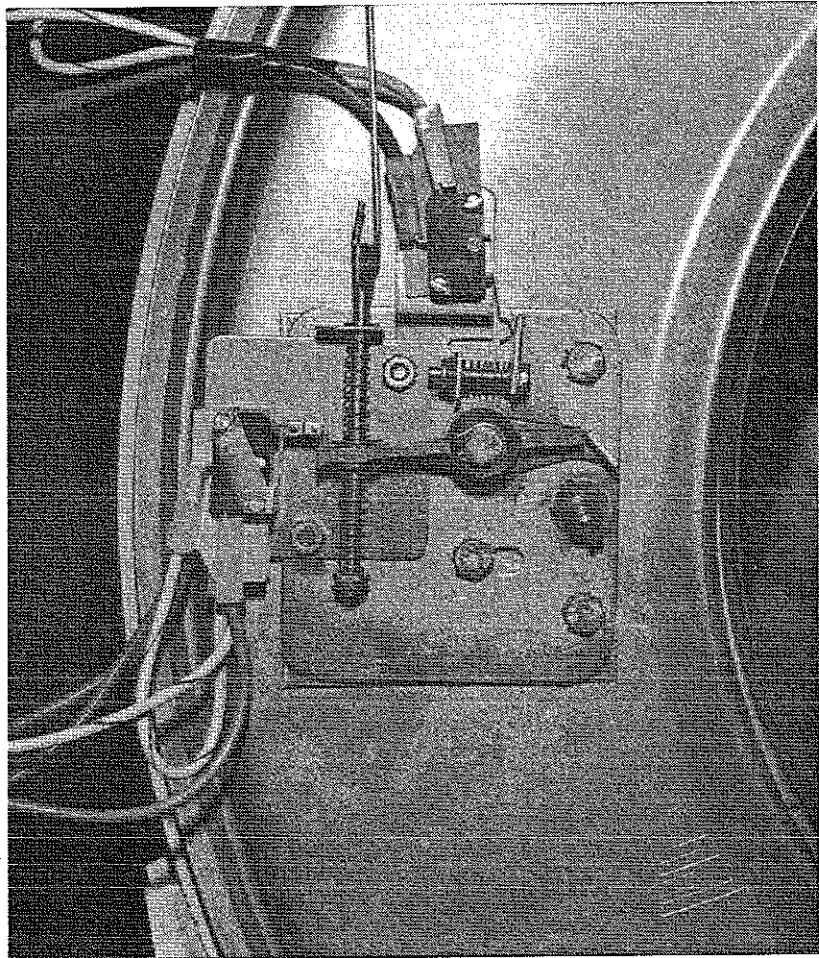
### Operation

After loading the clothing, the door should be closed and latched. The locking cam on the door contacts the latching switch actuator which closes the latching switch. The specified number of coins should now be added to start the washer. This satisfies the coin accumulator which powers the timer rapid advance motor. A timer contact provides power to the latching switch and with the door latched, the power travels through the latching switch to the door lock solenoid. This solenoid pulls up on the locking pawl by use of a linkage rod. The locking pawl has two jobs. The first is to lock the door. This is accomplished by blocking the locking cam on the door so that it can't rotate to unlock. The second job is to close the two piggyback lock sensing switches. These switches control power to all of the controls. If the door unlocks for any reason, these two switches will stop the machine. When the door handle is 1/4 to 1/2 of an inch from its fully closed position, the latching switch should close. The two piggyback lock sensing switches should be open when the door is unlocked and should be closed when the door is locked.

### Adjustment

The latching switch and the piggyback lock sensing switches all have slotted mountings for easy adjustment.

1. Set door cam over pin.
2. Tighten spring screw on switch actuator arm until it just clears cam OD. ( Note : Spring screw will have approx. 1/8" thread exposed at end beyond nut.)
3. Set .040 thickness gage between arm and latch switch operator.
4. Swivel switch until it clicks closed. Back it up just until it clicks for a reset. Tighten in that position. Check again for close and rest with gage in place. Remove gage.
5. Check for switch actuation at partial turn of cam as in operation above.
6. Check that lock arm swings by cam lobe to lock position when switch just clicks.



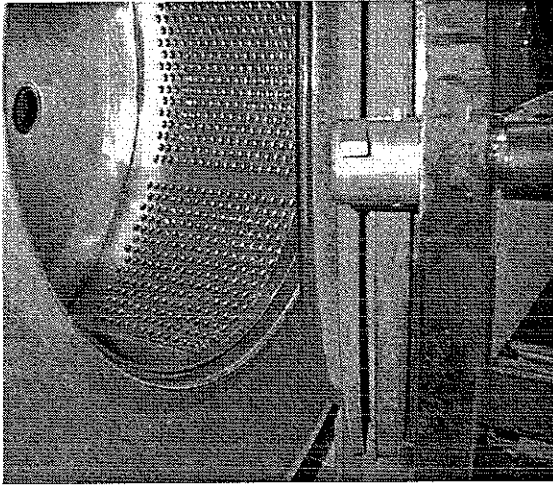


PHOTO # 1 SHOWS THE  
DOOR CAM AWAY FROM  
DOOR LOCK ASSEMBLY

PHOTO # 2  
SHOWS WHERE YOU  
WANT CLEARANCE

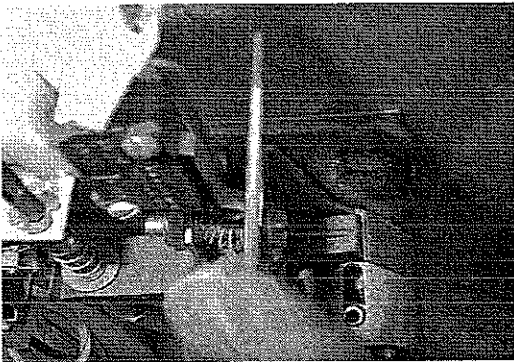
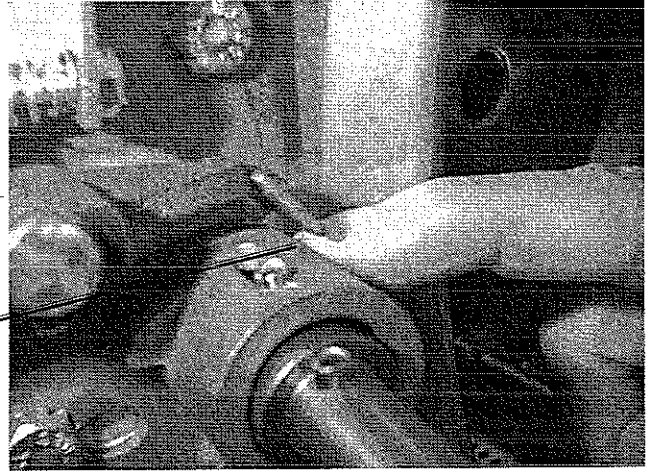
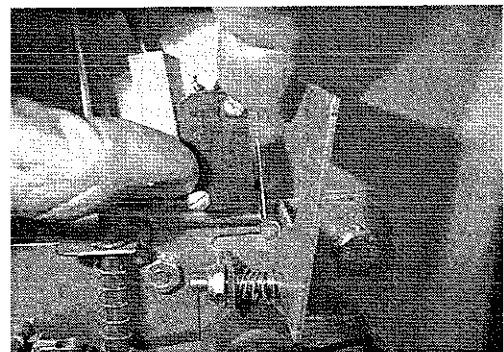


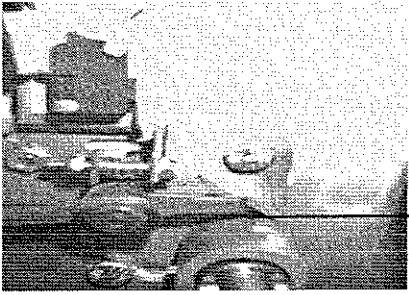
PHOTO # 3 SHOWS  
GUAGE IN PLACE  
FOR ADJUSTMENT

PHOTO #4  
SHOWS SWITCH SWIVELLING  
FOR ADJUSTMENT WITH  
GUAGE IN.

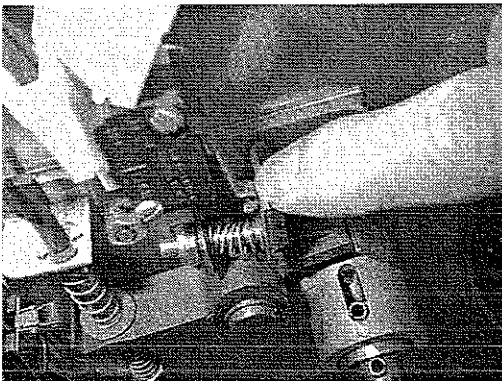
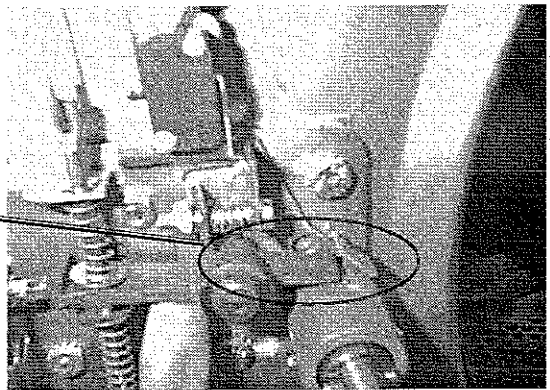




**PHOTO #5 SHOWS AREA  
WHERE CONTACT  
SHOULD BE MADE.**

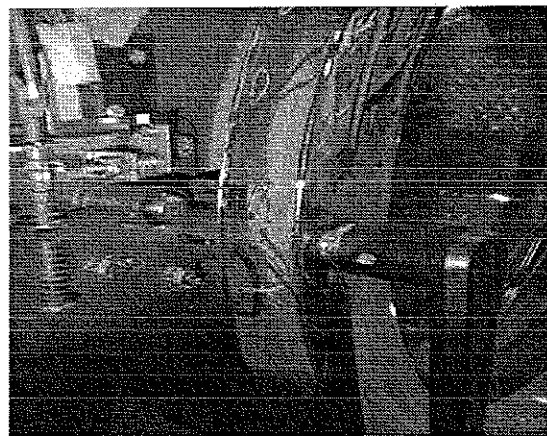


**PHOTO # 6  
SHOWS LOCK ARM  
ENGAGED**



**PHOTO #7  
JUST TO SHOW  
WITHOUT  
GUAGE IN PLACE**

**PHOTO # 8  
THE COMPLETE  
ASSEMBLY**



## Door Locking Solenoid

The door locking solenoid is powered shut with control voltage to lock the door and releases when voltage is removed. It is located in the left front corner of the washer.

## Thermoactuators

The thermoactuators are a safety device that keeps the door from immediately unlocking if power is lost while the machine is operating. They are mounted under the door locking solenoid.

### Lock Thermoactuator

Control voltage is applied to the lock thermoactuator at the beginning of the cycle making it extend and block the door locking solenoid. This keeps the door locked for approximately two minutes after a power failure occurs. The lock thermoactuator does not delay the door opening at the end of a normal cycle.

### Unlock Thermoactuator

To insure that the lock thermoactuator has retracted by the end of the cycle, one minute prior to the end of the cycle, the unlock thermoactuator is powered with control voltage making it extend and unblock the door locking solenoid.

## Loading Door Removal

- A. Support door to prevent dropping.
- B. Remove 3 bolts holding hinge retainer and set door off.

## Loading Door Disassembly

- A. Remove the loading door as outlined above.
- B. Lay the door on a flat surface with the glass down.
- C. While holding down on the door glass, lift up on the door ring and roll back the lip of the gasket with your fingers.
- D. Work all the way around the gasket and the glass is out.

## Loading Door Reassembly

- A. Lay the door ring face down on a flat surface.
- B. Start the glass into one side of the door gasket.
- C. Use one hand underneath to push the gasket out and the other hand on the top pulling the gasket in place.
- D. The front lip of the door gasket should be checked for proper seating.

## Loading Door Adjustment

The door can be adjusted by changing the number of shims behind the door hinge and the door lock assembly. The vertical fit of the door to the tub can be altered by loosening the door hinge bolts and raising or lowering the door before retightening. It is important for the door to be centered on the tub front. By chalking the nose of the tub and closing the door to transfer that line to the gasket, the centering can be evaluated. It is also important for door pressure to be similar around the door perimeter. Door pressure can be evaluated by inserting a dollar bill in several positions and tugging on it. See Parts Section for kit to increase door sealing pressure.

## Loading Door Hinge Removal

- A. First remove loading door, front panel, and trim ring.
- B. Remove 3 screws holding door hinge. Shims may be present between hinge and tub front. The number may be increased or decreased to adjust right side door pressure.

**NOTE: Door hinge mounting bolts penetrate tub front and require silicone sealer applied to holes when reinstalling.**

## Back Panel Removal

- A. Remove all screws holding back panel in position except the bottom row.
- B. The bottom row of screws are slotted and only need to be loosened and the panel will lift off.

**Note: The back panel is not only a safety requirement but also contributes to the rigidity of the cabinet.**

## Drive Belt Removal

Turn the drive belts off the basket pulley first and then remove from the motor pulley. Reverse this procedure for installation.

## Drive Motor

Refer to Specifications Chart for horse power and amperage draw on motors.

### Removal

- A. Remove the drive belt as explained above.
- B. Remove the tension spring and bracket.
- C. Disconnect the motor wires from the variable frequency drive.
- D. Loosen the set screws on the motor support shaft.
- E. Remove the motor support shaft.
- F. Lift motor out of machine.

**Note: On larger washers it is advisable to put a board under the motor and slide it out rather than lifting it.**

## Control Panel Name Plate

The name plate on washer front is adhesive backed.

### Removal

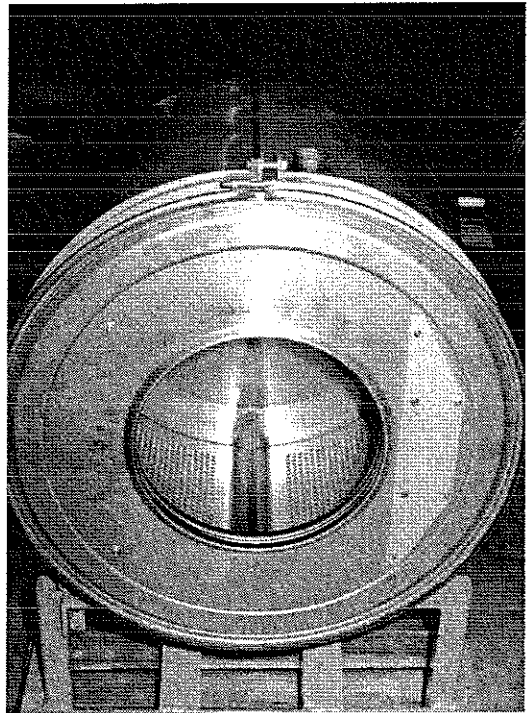
- A. The name plate may be removed by simply peeling it off.

### Installation

- A. First remove the coin acceptor.
- B. Remove any remaining glue from the control panel.
- C. Before removing the paper backing from the name plate, check fit to the control panel. The program push buttons and the coin acceptor opening are the locating guides.
- D. Remove the paper backing from the right side of the name plate, position it on the panel and press right end into place, then peel the backing from the left end and press into place.

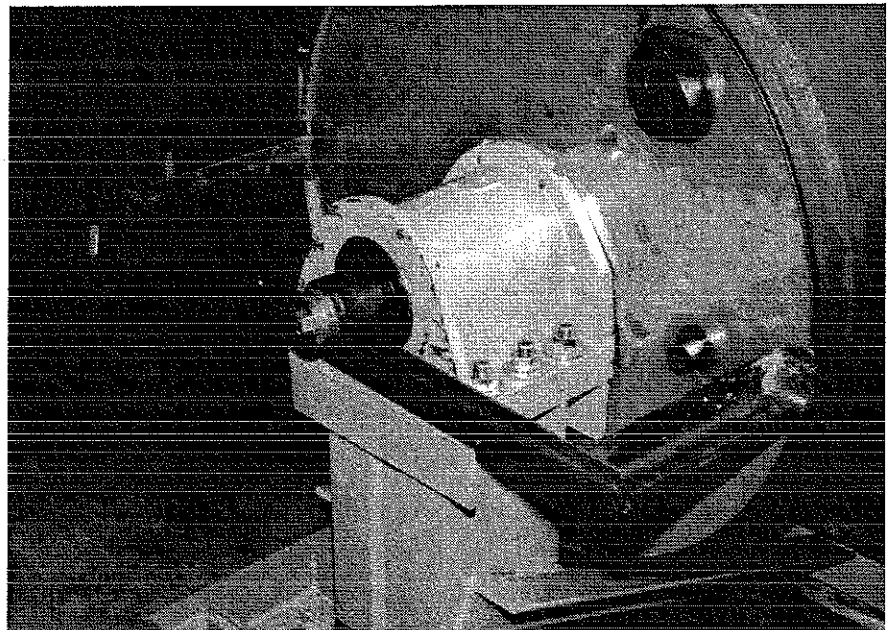
## Removal

- A. Remove the top panel as described previously.
- B. Remove lower service panel as described previously.
- C. Remove front panel as described previously.
- D. Remove masking ring as described previously.
- E. Remove door lock assembly. (Leave wires & pull rod in place)
- F. Remove clothes door.
- G. Remove tub front clamp ring.
- H. Remove tub front. Use a flat screw driver to pry the tub front loose.
- I. Remove the rear access panel.
- J. Remove the drive belts.
- K. Remove drive pulley.
  1. Remove 3 retaining screws.
  2. Insert 3 2" screws into the threaded removal holes.
  3. Alternately tighten these screws evenly to pull the pulley off.
- L. Remove pulley hub. Drive a flat screw driver into the slot in the hub and pull it from the shaft.
- M. Install cylinder puller.  
(Snap On part #CJ-84-C) Be sure to thread a bolt into the end of the cylinder shaft to protect the threads.
- N. Push the basket out.

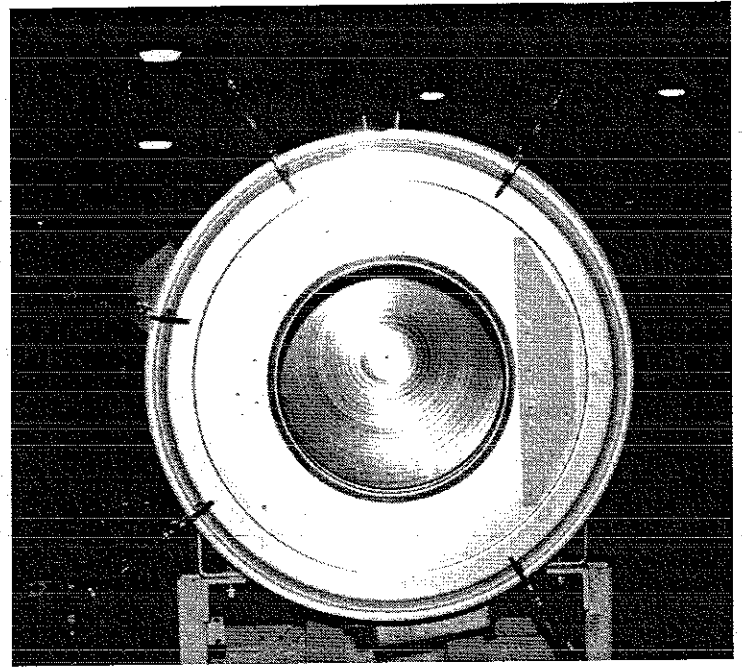


## Reassembly

- A. Use the hub of the drive pulley, a stack of 5/8" flat washers and a 3" long 5/8" bolt to pull the cylinder shaft through the bearings. After the 3" bolt a 2" long bolt will be required to finish pulling the cylinder shaft through.
- B. Remove the 1/2" bolt and nut from the top of the outer tub clamping band.
- C. Install Dexter Tool part # 8545-056-001 on the back of the outer tub to adjust tub front to cylinder clearance. Thread 5/8" bolt through tool and into cylinder shaft. Push the outer tub forward 1/4" to 1/2" with tool 8545-056-001 by tightening the 5/8" bolt. This will ease the installation of the outer tub front.
- D. Clean the silicone rubber off the tub front and the outer tub.
- E. Install new bead of silicone rubber on tub front.
- F. Install tub front.



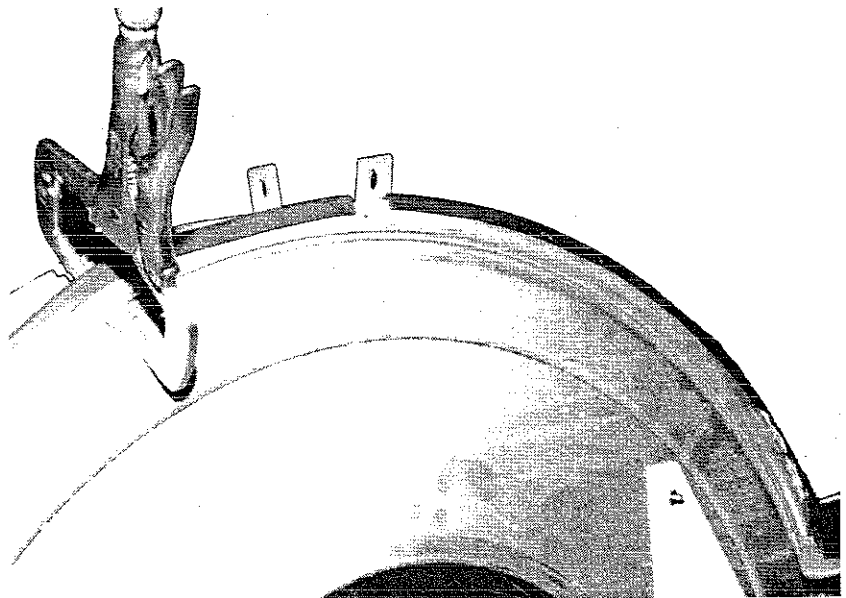
1. Align hole in top of tub front with notch in top of outer tub.
  2. Use 4-6 #11R vise grip clamps to hold tub front to outer tub. A rubber mallet may be needed to properly seat the tub front into the outer tub.
  3. Install tub front gasket around outer edge of tub front and outer tub flange. The opening should be centered at the top.
  4. Remove vise grips. The tub front gasket will hold the tub front in place.
- G. Install tub front clamp ring and tighten. Tap around the clamp ring with a rubber mallet to seat the ring and gasket while tightening the clamp ring bolt.
  - H. Adjust clearance between the outer tub front and the front lip of the cylinder to 5/16".
  - I. Tighten the outer tub clamping band.
  - J. If necessary, the outer tub may be adjusted up or down and side to side with the 2 bolts that fasten the bottom of the outer tub clamping band to the frame.
  - K. Remove Dexter Tool part 8545-056-001 from the back of the outer tub.
  - L. Install drive pulley.
    1. Install hub on cylinder shaft.
    2. Hold hub against rear bearing with 5/8" bolt and flat washer in end of cylinder shaft.
    3. Line up 3 unthreaded holes in pulley with the 3 threaded holes in hub.
    4. Insert 3 pulley bolts and tighten evenly alternating bolts to 30ft/lbs.



**Note: Overtightening or uneven tightening can break drive pulley.**

- M. Install drive belts.
- N. Install back panel.
- O. Install door lock. All mounting holes should be sealed with silicone rubber.
- P. Install door, masking ring, front panel, lower service panel and top.

**Torque all bolts according to the following chart.**



## Bolt Torque Chart

<u>Bolt Size</u>	<u>Where Used</u>	<u>Part Number</u>	<u>Torque</u>
7/16" Stainless Cap Screw	Outer Tub to Bearing Housing	9545-059-004	60-80 ft/lbs
3/4" Bolt	Bearing Housing to Frame	9545-057-002	200-300 ft/lbs
1/2" Bolt	Outer Tub Clamping Band to Frame	9545-017-013	70-110 ft/lbs
1/2" Bolt	Outer Tub Clamping Band - Top	9545-017-012	30-40 ft/lbs
3/8" Cap Screw	Drive Pulley to Hub	9545-029-011	30 ft/lbs

### Water Seals

#### Replacement

- A. Remove cylinder from washer (see Cylinder (basket) removal).
- B. Remove water seals from the seal mounting plate on the cylinder shaft. These are removed with your fingers.
- C. The primary and secondary seals that mount on the sealing ring may be slid over the shaft and seated on the metal sealing ring with your fingers. In the unlikely event that the metal ring that mounts these sealing rings were to be damaged or moved, a new one would need to be pressed on. The T-900 ring must be pushed against the stop on the shaft.

**After installing the seals, lubricate the faces of the seals with silicone grease.**

- D. Install cylinder (see Cylinder (basket) reassembly).

### Bearing Housing Assembly

#### Removal

- A. Remove cylinder from washer (see Cylinder (basket) removal).
- B. Remove 6 7/16" tub back to bearing housing cap screws.
- C. Remove 6 3/4" bearing housing to frame bolts.
- D. Remove bearing housing from frame.
- E. Remove the retaining ring next to the front bearing.
- F. The bearings are pressed into the housing and must be pressed back out.

#### Reassembly

- A. When installing new bearings into a bearing housing, first press the front (large) bearing into the housing until it bottoms and install the snap ring. With the bearing spacer in place, press the rear bearing in until the spacer is snug between the two bearings.

**Note: If the tub-back water-seal mating ring has been moved it must be cleaned and resealed with silastic around all 6 bolt holes and around the outer edge.**

- B. Set bearing housing on frame.
- C. Install and torque 6 tub back to bearing housing cap screws according to the previous chart.
- D. Install and torque 6 bearing housing to frame bolts according to the previous chart.
- E. Install cylinder (see Cylinder (basket) reassembly).

### Outer Tub

#### Removal

- A. The outer tub can easily be removed when the tub front and cylinder have been removed as outlined previously.
- B. At that point the only attachments to the chassis are the two front strap mounting bolts.

#### Reassembly

- A. See Cylinder (basket) reassembly.

# Section 5

## Trouble Shooting Guide, Wiring Schematics,

Symptom	Probable Cause	Suggested Remedy
Machine does not start	Power Supply	Check these areas: Circuit breakers, Voltage, Power leads, Power connections
	Door Switch	Check for continuity through door switch when door closed. If no continuity, adjust or replace door switch.
	Control Breaker	Check 1.5 amp breaker for continuity. If no continuity, replace breaker.
	Control Transformer	Check voltage output from control transformer for 120VAC. If voltage is incorrect, replace transformer.
	Coin Acceptor	Check coin switch to make sure coins trip switch and give continuity across switch when closed. If no continuity, adjust or replace switch.
	Accumulator Transformer	Check accumulator transformer for 12VAC output to accumulator. If no voltage, replace transformer.
	Coin Accumulator	Check accumulator to see that display is showing correct number of coins to start. Check accumulator for short 120VAC output signal at orange/white wire when preset number of coins is reached. If no display or output signal, replace coin accumulator.
	Timer	Check to insure that the timer is in the "off" position to supply 120VAC through the "Start" cam to the coin accumulator board.
Machine will not accept and count coins	Timer, Rapid Advance Motor	Check the rapid advance motor for continuity and replace if no continuity.
	Coin Acceptor	Check coin acceptor for any type of blockage or damage. Clean, adjust or replace the acceptor as necessary.
	Power Supply	Check these areas: Circuit breakers, Voltage, Power leads, Power connections
	Coin Accumulator	Check accumulator to see that display is showing correct number of coins to start. If no display, replace coin accumulator.
	Timer	Timer must be in off position, machine had to finish previous cycle to reset coin accumulator board.

Symptom	Probable Cause	Suggested Remedy
Machine will not accept and count coins (continued)	Control Breaker	Check 1.5 amp breaker for continuity. If no continuity, replace breaker.
Door does not lock	Timer Position	The following sequence must have taken place to advance the timer before the door locks. -Loading door closed -Proper number of coins inserted to start machine -Accumulator counted and credited coins to advance timer into cycle closing "on-off" timer contact.
	Door locking solenoid	Check to insure that solenoid is receiving 120VAC from S1 door switch. If it is, replace solenoid.
	Door Switch	Check for continuity through door latch switch when door is closed. If no continuity, adjust or replace door switch.
Door will not open	Thermoactuator	Check to see if thermoactuator(s) and/or its mechanism is stuck or binding and not allowing the door lock solenoid to open. Check to be sure that the locking thermoactuator is not receiving 120VAC during the last 1 1/2 minutes of the cycle. Also check to see that the unlocking thermoactuator is receiving 120VAC during the last minute of the cycle. If the thermoactuators do not receive voltage at the correct times, change the timer. If the timing and voltage are correct, replace the thermoactuator.
	Door Rod	Check to see that door rod from solenoid to lock ass'y is long enough to allow lock ass'y to disengage. If not, adjust rod.
	Door Lock Solenoid	Check that door lock solenoid is not stuck closed. If stuck, replace solenoid.
	Timer	Make sure machine is in "off" position allowing Timer to authorize door unlock.
	Water Valves	Check to insure that water valves are operating. If not, check for 120VAC to water valve from timer. If 120VAC, clean screens. If still no operation, change water valve. If no voltage check pressure switch then change timer.
Machine starts but timer will not advance	Drain Valve	Check to insure that drain valve is closing. If not, check for 120VAC to drain valve from timer. If 120VAC, change or clean drain valve. If no voltage, change timer.

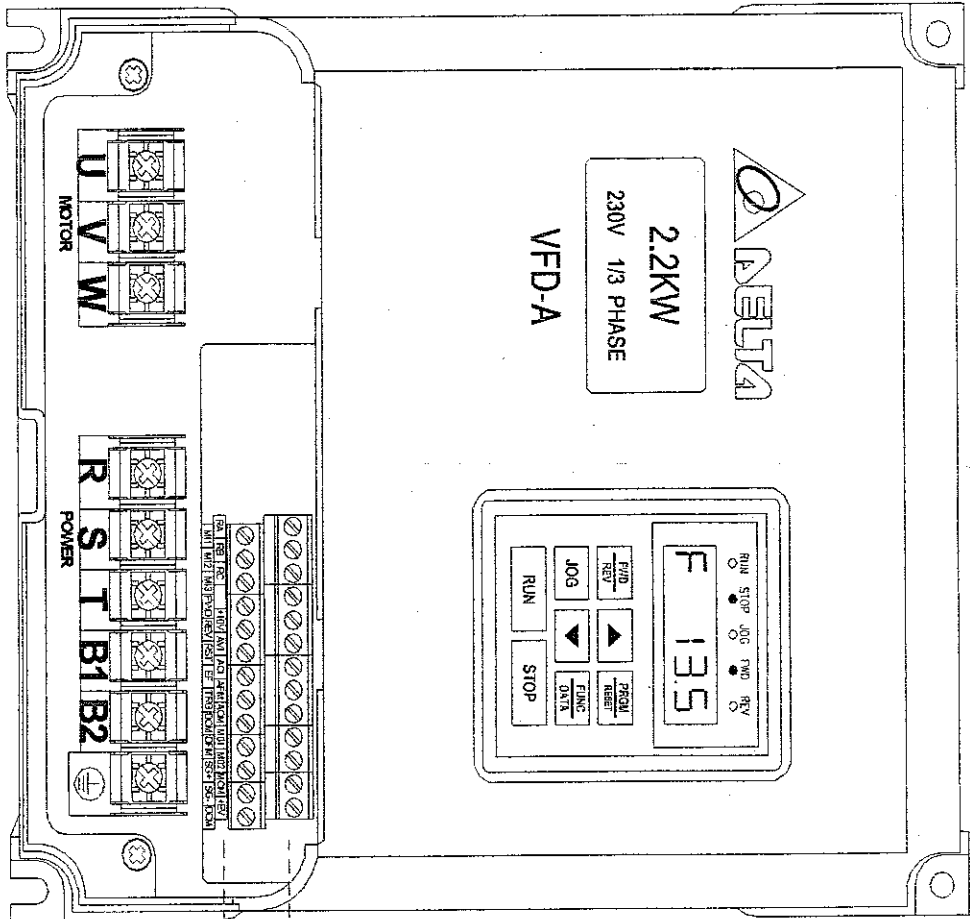


<b>Symptom</b>	<b>Probable Cause</b>	<b>Suggested Remedy</b>
Machine starts but will not advance through cycle (continued)	Fill Hose Screens & Water Valve Screens	Check all screens for obstructions and clean.
	Water	Check to insure that water is turned on and operating.
	Pressure Switch Hose	Check hose for holes. Be sure the inlet end of the large part of the hose is lower than the rest of the hose and is free of debris.
	Pressure Switch	Check to insure that pressure switch has continuity between #11 & #12. If no continuity, check pressure switch hose for obstruction. If hose okay, change pressure switch.
Hot water does enter tub in wash	Main Timer Drive Motor	If power is available to main timer drive motor but it doesn't run, replace timer motor.
	Water Valve Coil	Check coil continuity at terminals and replace if not no continuity.
	Water Inlet Screens	Check water inlet screens for blockage and clean if necessary.
	Water	Check to insure that water is turned on and operating.
	Timer	Advance machine into wash cycle and check for 120VAC at red/blue wire coming from timer.
	Water Temperature Selector Switch	Check switch for continuity between red/blue wire and red/yellow wire when Hot is selected. If no continuity, change switch.
	Pressure Switch	Check pressure switch continuity between terminals #11 & #12. If no continuity, check pressure switch hose for obstruction. If hose okay, change pressure switch.
No cold water to tub in wash	Water Valve Coil	Check coil continuity at terminals and replace if no continuity.
	Water Inlet Screens	Check water inlet screens for blockage and clean if necessary.
	Water	Check to insure that water is turned on and operating.
	Pressure Switch	Check pressure switch continuity between terminals #11 & #12. If no continuity, check pressure switch hose for obstruction. If hose okay, change pressure switch.

Symptom	Probable Cause	Suggested Remedy
No cold water to tub in wash (continued)	Timer	Choose cold cycle, advance to wash, check for voltage on white/black from timer. If no voltage, replace timer.
	Water Temperature Selector Switch	Choose cold cycle, advance to wash and check wht/org wire from selector switch for 120VAC. If no voltage, change switch.
No hot water in detergent dispenser	Water Valve Coil	Check coil continuity at terminals and replace if no continuity.
	Water Inlet Screens	Check water inlet screens for blockage and clean if necessary.
	Water	Check to insure that water is turned on and operating.
	Timer	Advance to wash, check for voltage on red/org from timer. If no voltage, replace timer.
Water does not flush softener compartment.	Water Valve Coil	Check coil continuity at terminals and replace if no continuity.
	Water Inlet Screens	Check water inlet screens for blockage and clean if necessary.
	Water	Check to insure that water is turned on and operating.
	Pressure Switch	Check pressure switch continuity between terminals #11 & #12. If no continuity, check pressure switch hose for obstruction. If hose okay, change pressure switch.
	Timer	Advance machine to final rinse and check for voltage at wht/blue wire coming from timer. If no voltage, replace timer.
Water comes in but level does not rise	Drain Valve (open)	Check these areas - Drain valve blockage - Drain valve motor and gear train. If power but drain valve does not close, replace valve. - Power to the drain valve. If no power to drain valve, check (brn/yel) circuit for power.
Water level too high	Pressure Switch	Check for blockage in pressure switch hose. Check for pressure switch opening circuit across terminals #11 & #12. Replace switch if contacts do not open.
Water drains slowly	Drain System	Check hoses and drain valve for blockage. Clean if necessary. Check building drains for blockage or inadequate size.

Symptom	Probable Cause	Suggested Remedy
Machine tumbles in only one direction	Reversing Timer	Check to see that reversing timer is running. Check for alternating 24VDC at blue and at orange from reversing timer to signal reversing operation to drive. If not running or no voltage, replace reversing timer.
	Variable Frequency Drive	Check blue and orange wires on variable frequency drive for alternating 24VDC for forward and reverse direction from the reversing timer. If no voltage, see reversing timer above. Be sure to check wire connections at drive. If 24VDC at drive, replace drive.
Does not give intermediate spin	Pressure Switch	Check pressure switch for continuity across terminals #11 & #12 indicating pressure switch has reset to the empty position. If no continuity, change pressure switch.
	Reversing Timer	Check to see if running. Check for 24VDC output on blue/wht wire. If not running or no output, change reversing timer.
	Spin Relay R2	Check spin relay coil for continuity, replace if shorted. Check for 24VDC input to spin relay contacts. Check for 24VDC out of relay on red & black wires. If input voltage is okay and there is no output voltage, change relay.
	Timer	Advance to spin cycle, check for 120VAC on red/blk from main timer. If no voltage, change timer.
Machine starts and advances through cycle but motor does not operate	Variable Frequency Drive	<p>Check Variable frequency drive  Green light on back illuminated, Okay.  Red light on back illuminated, do the following:</p> <ol style="list-style-type: none"> <li>1. Disconnect power to washer for two minutes to reset variable frequency drive.  Reconnect to power and check for 13.5 reading on digital readout.</li> <li>2. Check incoming power to washer for correct voltage. Line voltage out of the specified operating range will cause the drive to fault.</li> <li>3. Check motor. Disconnect from power. Push tab on bottom of drive and remove lower cover.  <b>(Do not remove complete cover as it will damage the drive)</b></li> </ol> <p>Disconnect the three gray wires that operate the motor from terminals "U", "V", and "W" in the drive. Reconnect power to the washer and check digital readout for 13.5</p>

Symptom	Probable Cause	Suggested Remedy
Machine starts and advances through cycle but motor does not operate (continued)	R1 Relay	Start machine to verify that door locks and check for 120VAC to R1 (run relay) coil. Check for continuity across relay coil. Check for 24VDC input on white wire and 24VDC output on blk/red wire. If no output, replace relay.
	Reversing Timer	Check to see that reversing timer is running. Check for alternating 24VDC at blue and at orange from reversing timer to signal reversing operation to drive. If not running or no output voltage, replace reversing timer.
Intermediate spin speed works-no high extract	Program Timer	Advance to final extract, check red/green wire from timer for 120VAC to extract relay. If no voltage, replace timer.
	Extract Relay (R3)	Check relay for continuity through coil. Check output on green wire from extract relay for 24VDC. If no continuity or no 24VDC, replace relay.
Machine does not stop at end of cycle	Coin accumulator	Check for continuous output from terminal where orange-white wire connects to accumulator. If so replace accumulator.
Water leakage around loading door	Door Adjustment	Door may need adjustment due to abuse or wear. Check tightness around perimeter using a dollar bill. Adjust left to right tightness by shims at door lock or hinge side. It is important to center gasket to tub opening before tightening door to hinge bolts. Chalk may be used on tub front to show point of contact with tub. If gasket is deformed, worn, or damaged, replace. Refer to parts section for door gasket expander kit.
Excessive vibration	Mounting System	Check these areas: - Strength of mounting structure, concrete or base. - Mounting bolts may be loose and need tightening.
	Drive Belt	- Worn drive belt can cause vibration and noise.
	Pulleys	- Damaged pulleys.



DRIVE STATUS, AFTER POWER APPLIED,  
WITH NO CONTROL SIGNAL FROM  
WASHER CONTROLS.

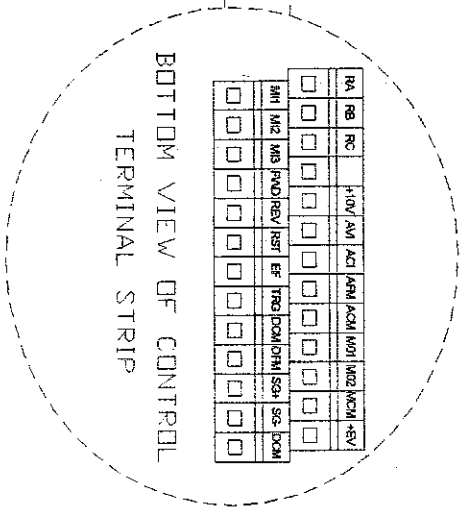
55# WASHER CONTROL TYPE: MICRO or RELAY

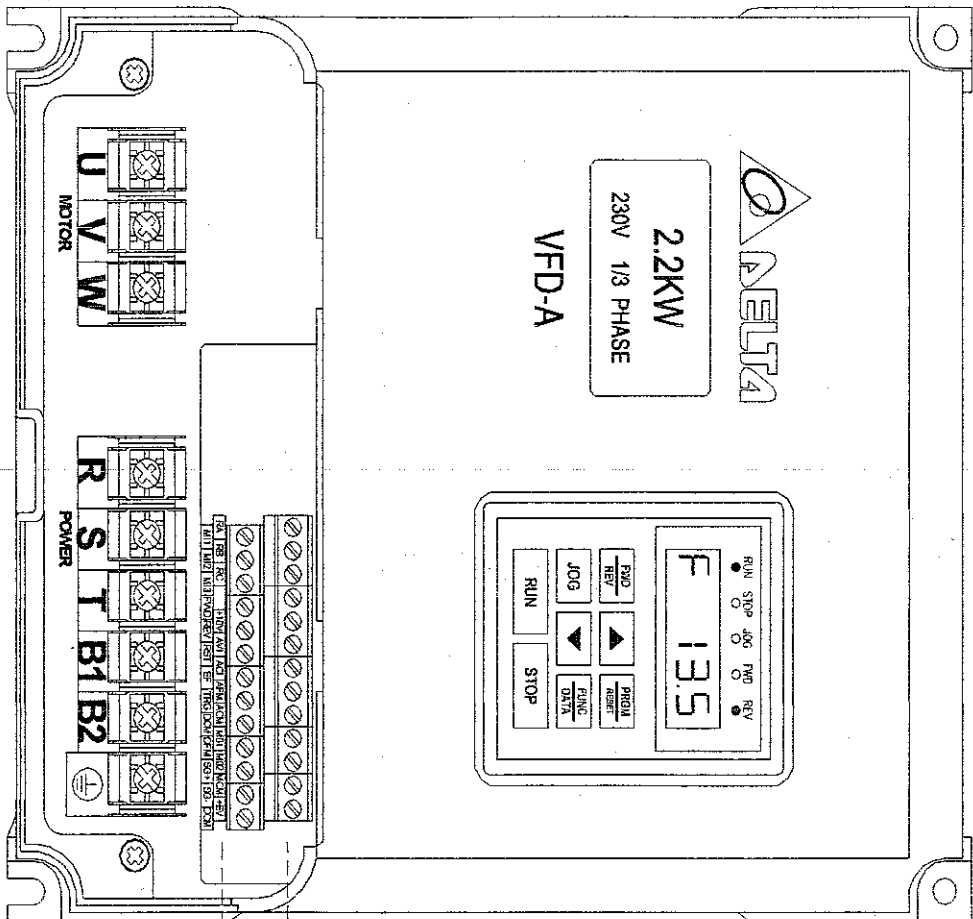
All control terminal voltages will be D.C. The negative lead of the voltmeter should be placed on terminal DCM. The D.C. supply of the drive, will vary from 420 to 424 Volts.

Solid circles, or drive display L.E.D.s, indicate that the L.E.D. is illuminated; Circles with four lines protruding at 45, 135, 225, and 315 degrees (X) indicate that the L.E.D. is blinking.

VOLTAGE READINGS:

- M11 (GRND) TO DCM (WHT) = 24 VOLTS
- M12 (BLK) TO DCM (WHT) = 24 VOLTS
- M13 (RED) TO DCM (WHT) = 24 VOLTS
- FWD (BLU) TO DCM (WHT) = 24 VOLTS
- REV (GRND) TO DCM (WHT) = 24 VOLTS



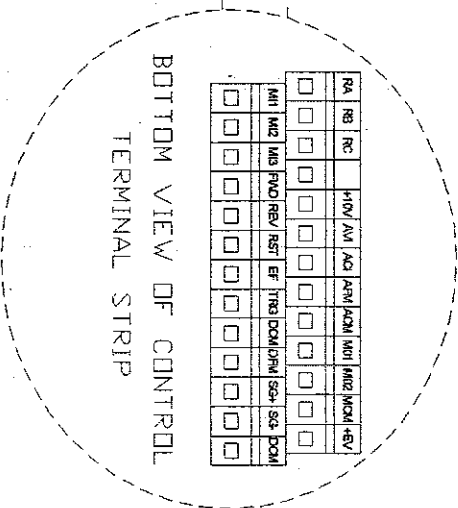


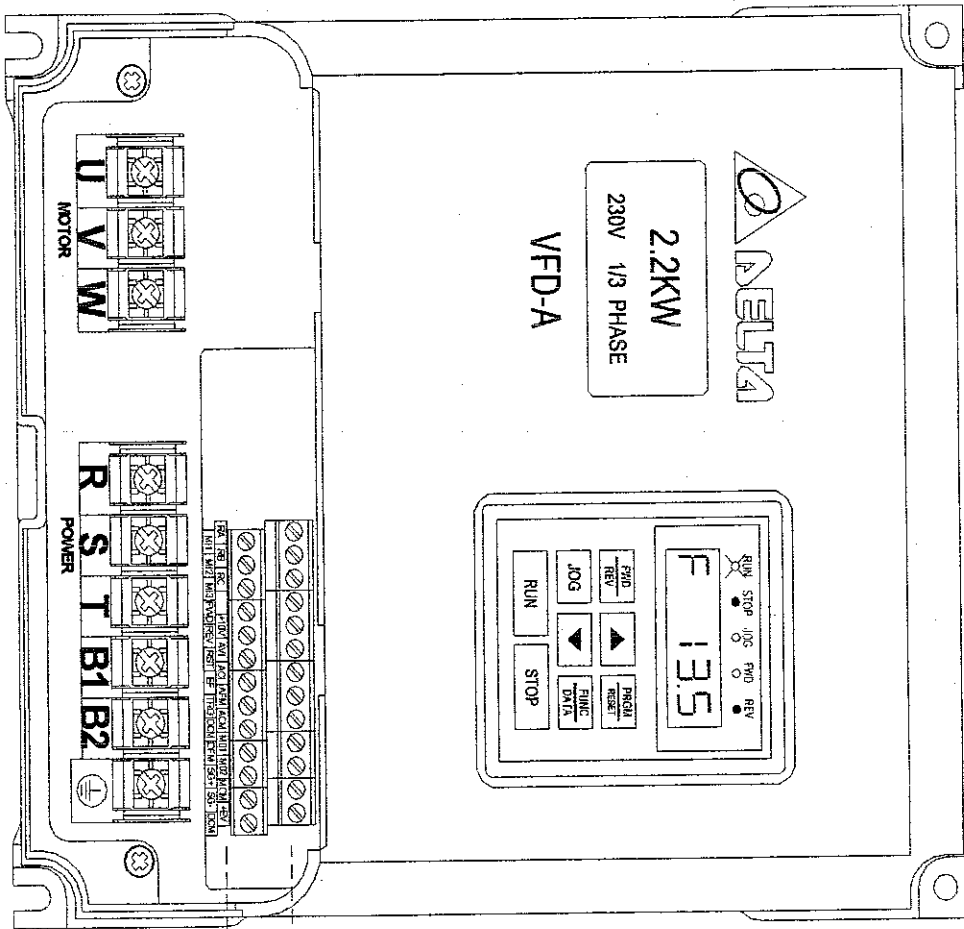
DRIVE STATUS WITH REVERSE TUMBLE  
SIGNAL FROM WASHER CONTROLS.

55# WASHER CONTROL TYPE: MICRO or NON-MICRO

All control terminal voltages will be DC. The negative lead of the voltmeter should be placed on terminal DCM. The DC supply of the drive will vary from +20 to +24 Volts.  
Solid circles, on drive display L.E.D.s, indicate that the L.E.D. is illuminated. Circles with four lines protruding at 45, 135, 225, and 315 degrees (°) indicate that the L.E.D. is blinking.

VOLTAGE READINGS:  
M11 (GRND) TO DCM (WHT) = 24 VOLTS  
M12 (BLK) TO DCM (WHT) = 24 VOLTS  
M13 (RED) TO DCM (WHT) = 24 VOLTS  
FWD (BLU) TO DCM (WHT) = 24 VOLTS  
REV (DRN) TO DCM (WHT) = 0 VOLTS





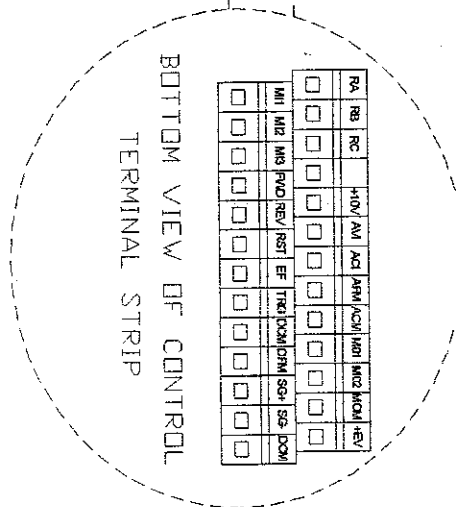
DRIVE STATUS WHILE DECELERATING FROM REVERSE TUMBLE SIGNAL FROM WASHER CONTROLS.

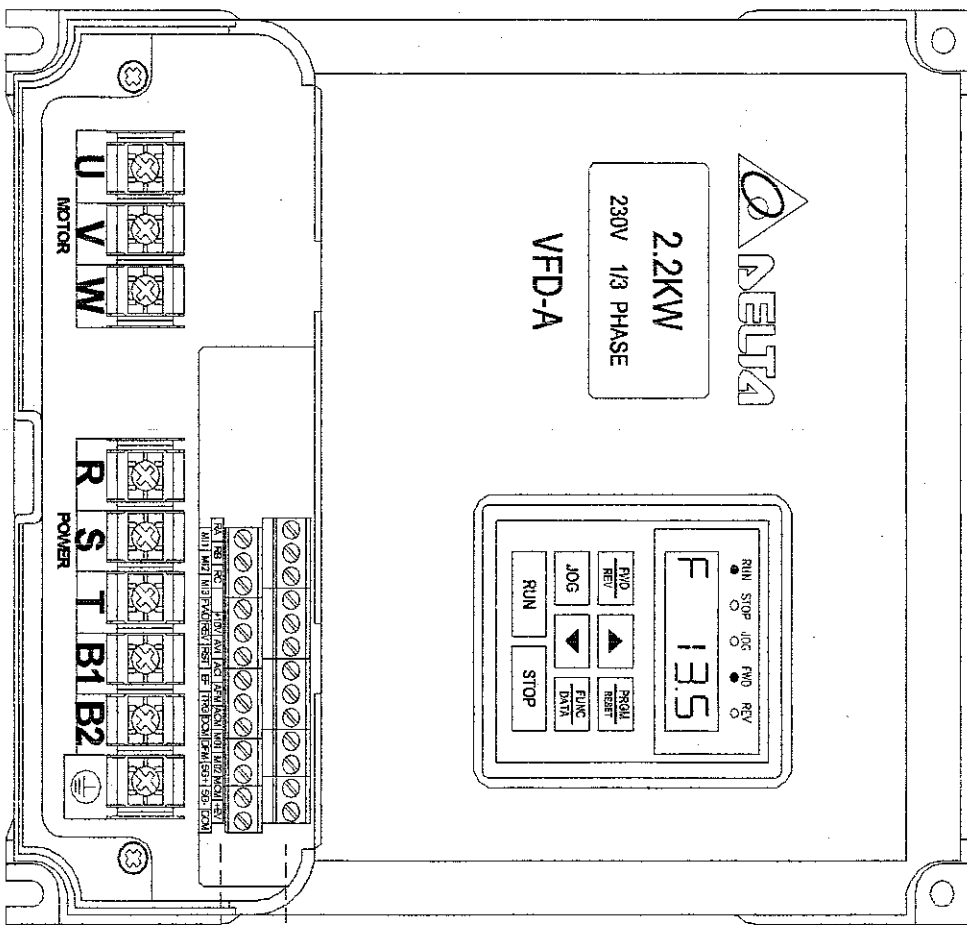
**55# WASHER CONTROL TYPE: MICRO or NON-MICRO**

All control terminal voltages will be D.C. The negative lead of the voltmeter should be placed on terminal DCM. The D.C. supply of the drive, will vary from +20 to +24 VOLTS. Solid circles, on drive display L.E.D.s, indicate that the L.E.D. is illuminated. Circles with four lines protruding at 45, 135, 225, and 315 degrees (X) indicate that the L.E.D. is blinking.

**VOLTAGE READINGS:**

- M11 (GRND) TO DCM (WHT) = 24 VOLTS
- M12 (BLK) TO DCM (WHT) = 24 VOLTS
- M13 (RED) TO DCM (WHT) = 24 VOLTS
- FVND (BLU) TO DCM (WHT) = 24 VOLTS
- REV (GRN) TO DCM (WHT) = 24 VOLTS





**DRIVE STATUS WITH FORWARD TUMBLE SIGNAL FROM WASHER CONTROLS.**

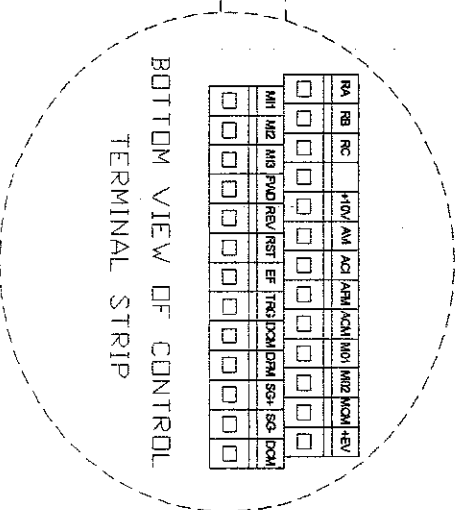
**55# WASHER CONTROL TYPE: MICRO or NON-MICRO**

All control terminal voltages will be D.C. The negative lead of the voltmeter should be placed on terminal DCM. The D.C. supply of the drive will vary from +20 to +24 Volts.

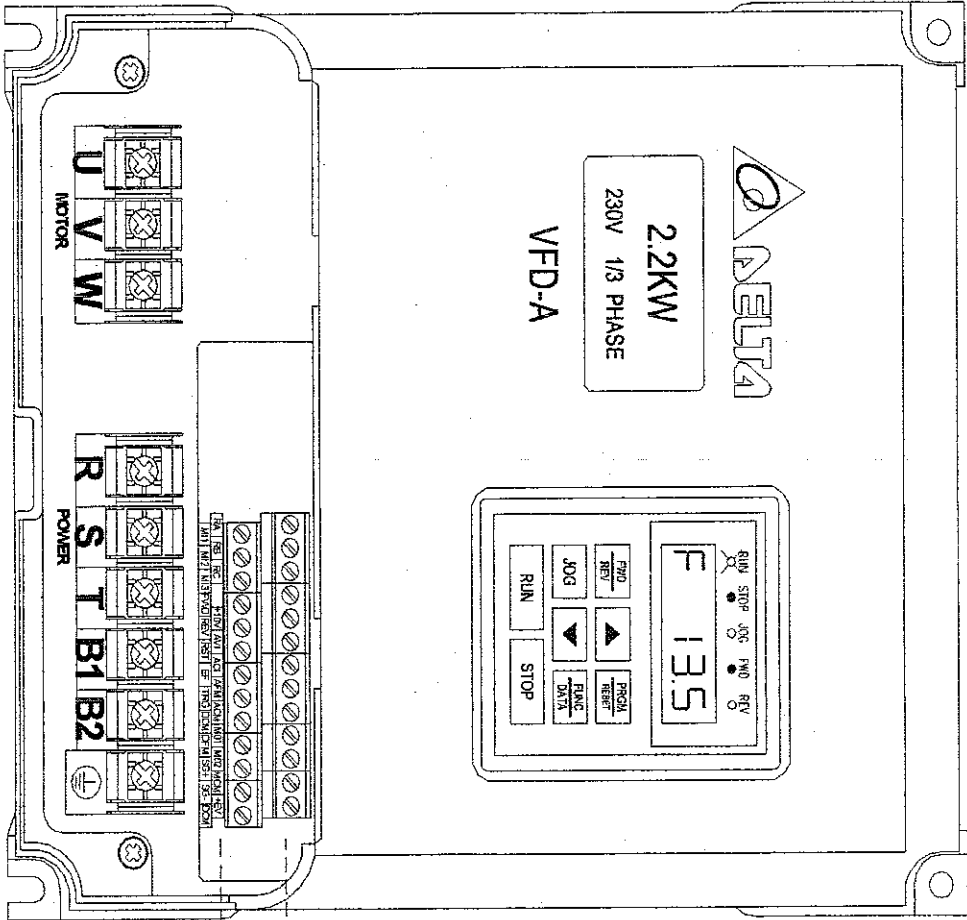
Solid circles, on drive display L.E.D.s, indicate that the L.E.D. is illuminated. Circles with four lines protruding at 45, 135, 225, and 315 degrees (°) indicate that the L.E.D. is blinking.

**VOLTAGE READINGS:**

- M11 (GRN) TO DCM (WHT) = 24 VOLTS
- M12 (BLK) TO DCM (WHT) = 24 VOLTS
- M13 (RED) TO DCM (WHT) = 24 VOLTS
- FWD (BLU) TO DCM (WHT) = 0 VOLTS
- REV (BRN) TO DCM (WHT) = 24 VOLTS







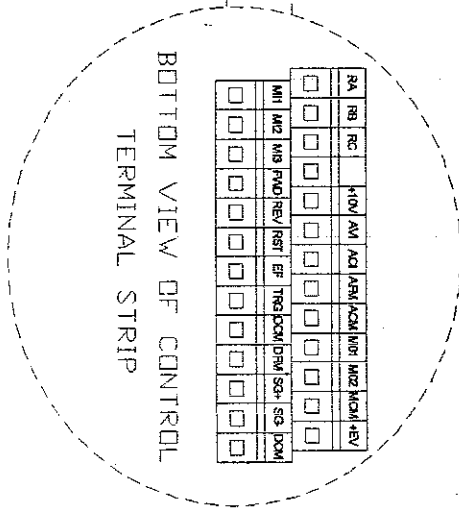
DRIVE STATUS WHILE DECELERATING FROM FORWARD TUMBLE SIGNAL FROM WASHER CONTROLS.

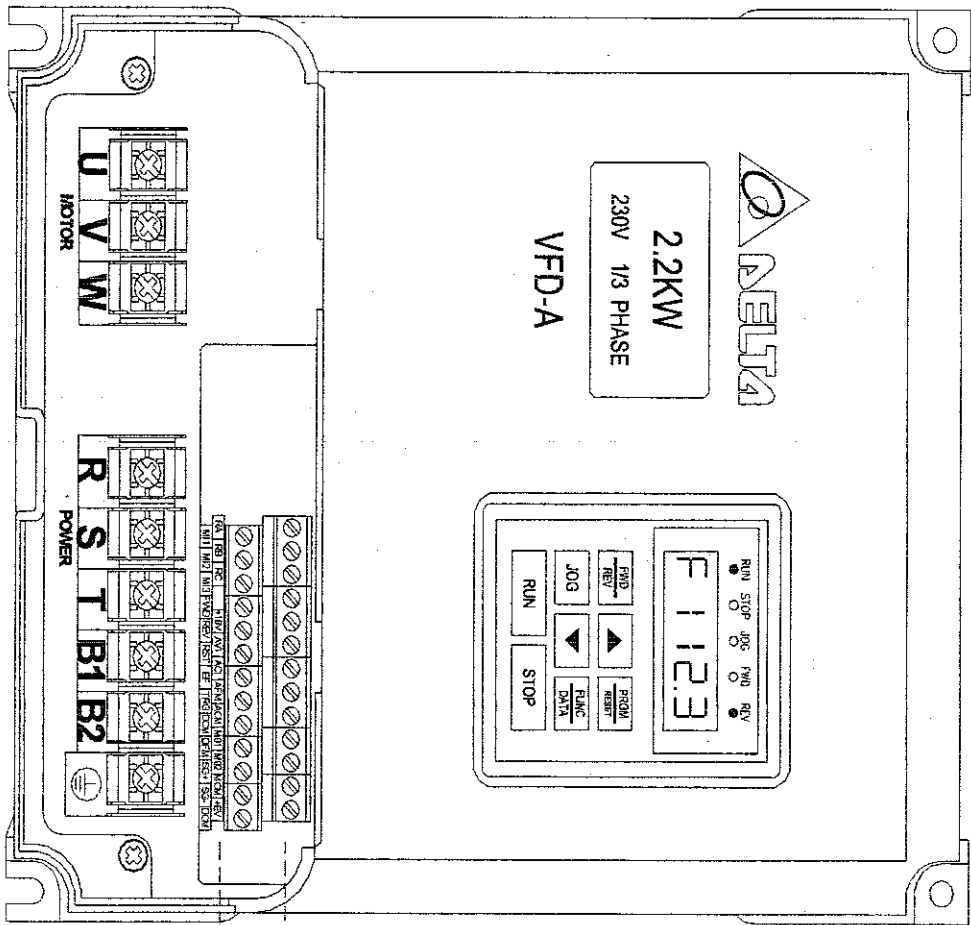
**55# WASHER CONTROL TYPE: MICRO or NON-MICRO**

All control terminal voltages will be DC. The negative lead of the voltmeter should be placed on terminal DCM. The DC supply of the driver will vary from +20 to +24 Volts.  
 Solid circles, on drive display L.E.D.s, indicate that the L.E.D. is illuminated. Circles with four lines protruding at 45, 135, 225, and 315 degrees (X) indicate that the L.E.D. is blinking.

**VOLTAGE READINGS:**

- M11 (GRND) TO DCM (WHT) = 24 VOLTS
- M12 (BLK) TO DCM (WHT) = 24 VOLTS
- M13 (RED) TO DCM (WHT) = 24 VOLTS
- FWD (BLU) TO DCM (WHT) = 24 VOLTS
- REV (GRN) TO DCM (WHT) = 24 VOLTS





**DRIVE STATUS WITH INTERMEDIATE  
EXTRACT SIGNAL FROM WASHER  
CONTROLS.**

**55# WASHER CONTROL TYPE: NON-MICRO (RELAY)**

All control terminal voltages will be D.C. The negative lead of the voltmeter should be placed on terminal DCM. The D.C. supply of the drive, will vary from +20 to +24 Volts.

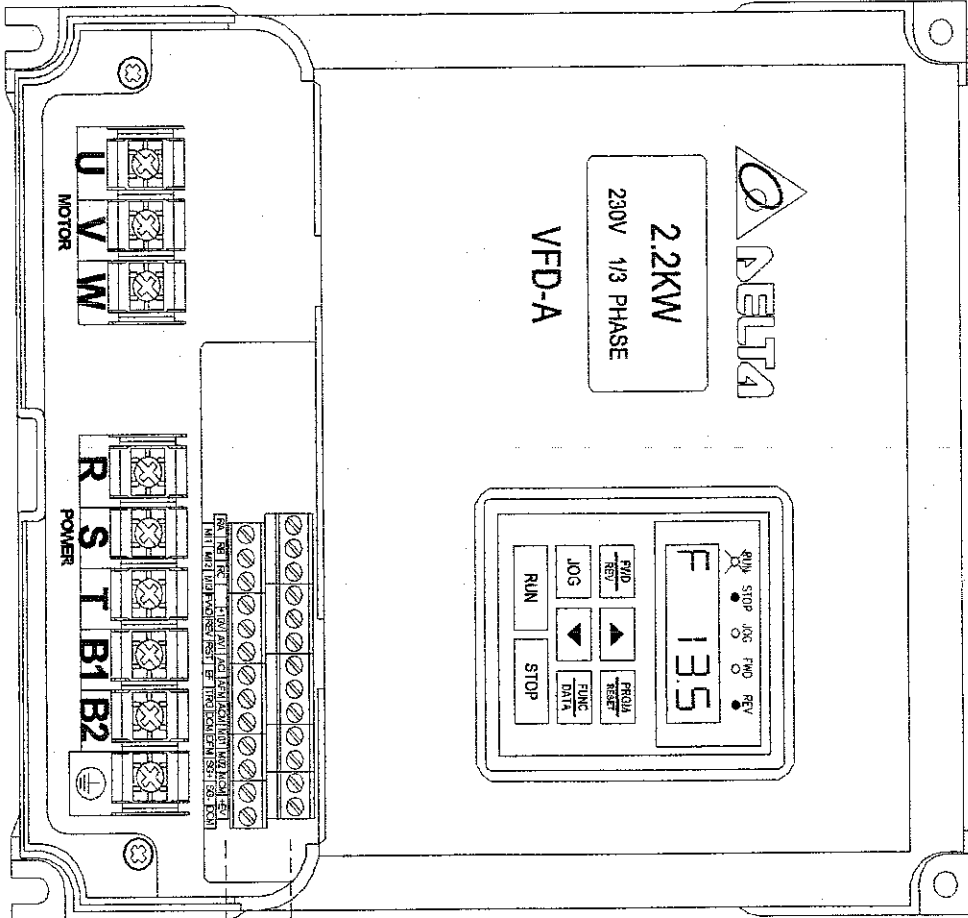
Solid circles, on drive display L.E.D.s, indicate that the L.E.D. is illuminated. Circles with four lines protruding at 45, 135, 225, and 315 degrees (°) indicate that the L.E.D. is blinking.

**VOLTAGE READINGS:**

- M11 (GRN) TO DCM (WHT) = 24 VOLTS
- M12 (BLK) TO DCM (WHT) = 0 VOLTS
- M13 (RED) TO DCM (WHT) = 0 VOLTS
- FVD (BLU) TO DCM (WHT) = 24 VOLTS
- REV (BRN) TO DCM (WHT) = 0 VOLTS

**BOTTOM VIEW OF CONTROL  
TERMINAL STRIP**

RA	RB	RC	*10V	AI1	AI2	AI3	AI4	AI5	AI6	AI7	AI8	AI9	AI10	AI11	AI12	AI13	AI14	AI15	AI16
<input type="checkbox"/>	<input type="checkbox"/>	<input type="checkbox"/>	<input type="checkbox"/>	<input type="checkbox"/>	<input type="checkbox"/>	<input type="checkbox"/>	<input type="checkbox"/>	<input type="checkbox"/>	<input type="checkbox"/>	<input type="checkbox"/>	<input type="checkbox"/>	<input type="checkbox"/>	<input type="checkbox"/>	<input type="checkbox"/>	<input type="checkbox"/>	<input type="checkbox"/>	<input type="checkbox"/>	<input type="checkbox"/>	<input type="checkbox"/>
M11	M12	M13	FVD	REV	RST	EF	TRG	DCM	DRN	SG+	SG-	DCM							
<input type="checkbox"/>	<input type="checkbox"/>	<input type="checkbox"/>	<input type="checkbox"/>	<input type="checkbox"/>	<input type="checkbox"/>	<input type="checkbox"/>	<input type="checkbox"/>	<input type="checkbox"/>	<input type="checkbox"/>	<input type="checkbox"/>	<input type="checkbox"/>	<input type="checkbox"/>	<input type="checkbox"/>	<input type="checkbox"/>	<input type="checkbox"/>	<input type="checkbox"/>	<input type="checkbox"/>	<input type="checkbox"/>	<input type="checkbox"/>



DRIVE STATUS WHILE DECELERATING FROM INTERMEDIATE EXTRACT SIGNAL FROM WASHER CONTROLS.

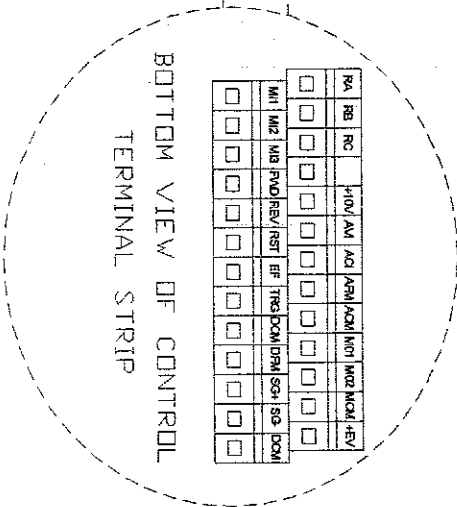
**55# WASHER CONTROL TYPE: MICRO or NON-MICRO**

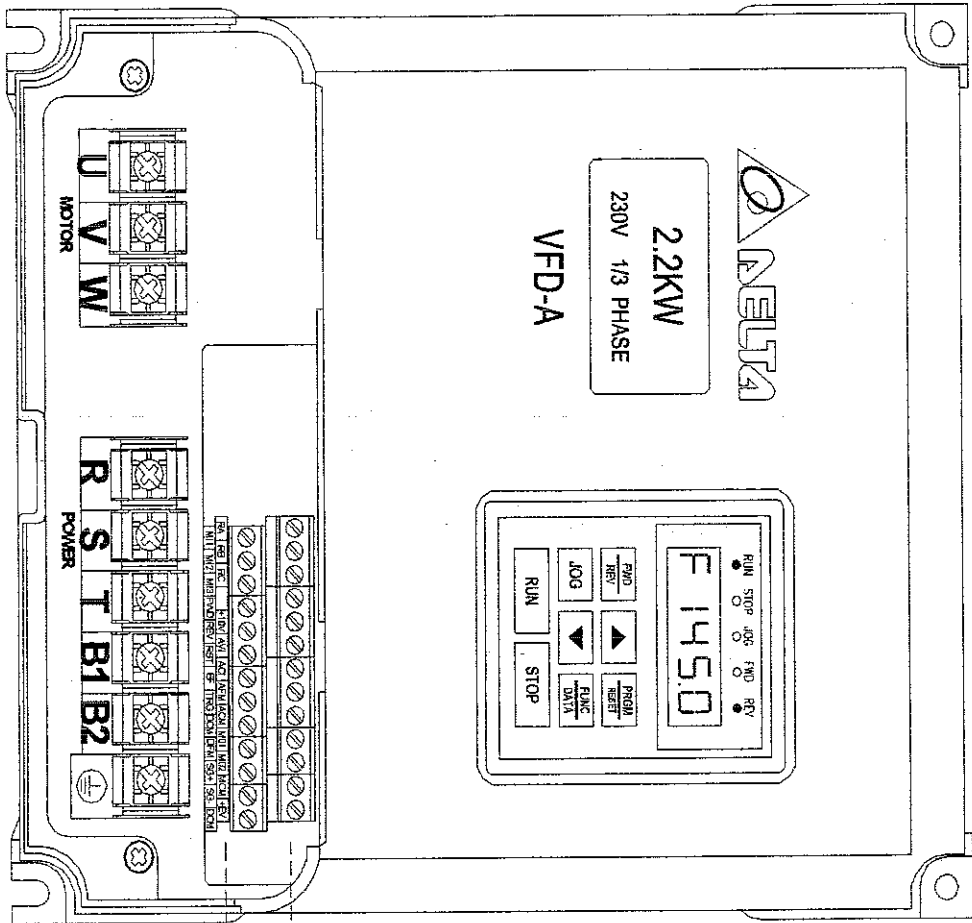
All control terminal voltages will be D.C. The negative lead of the voltmeter should be placed on terminal DCM. The D.C. supply of the drive will vary from +20 to +24 Volts.

Solid circles, on drive display L.E.D.s, indicate that the L.E.D. is illuminated. Circles with four lines protruding at 45, 135, 225, and 315 degrees (X) indicate that the L.E.D. is blinking.

**VOLTAGE READINGS:**

- M11 (GRN) TO DCM (WHT) = 24 VOLTS
- M12 (BLK) TO DCM (WHT) = 24 VOLTS
- M13 (RED) TO DCM (WHT) = 24 VOLTS
- FWD (BLU) TO DCM (WHT) = 24 VOLTS
- REV (DRN) TO DCM (WHT) = 24 VOLTS





**DRIVE STATUS WITH EXTRACT SIGNAL FROM 100G WASHER CONTROLS.**

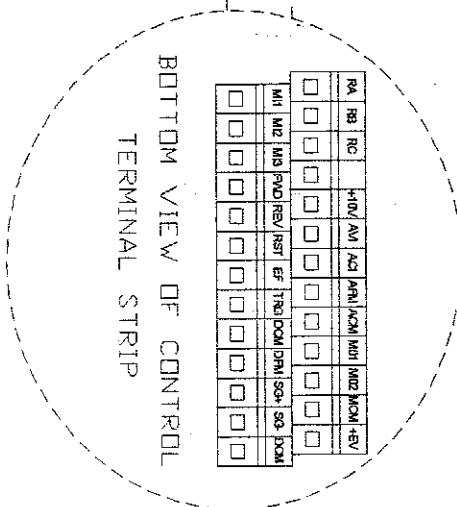
**55# WASHER CONTROL TYPE: MICRO or NON-MICRO**

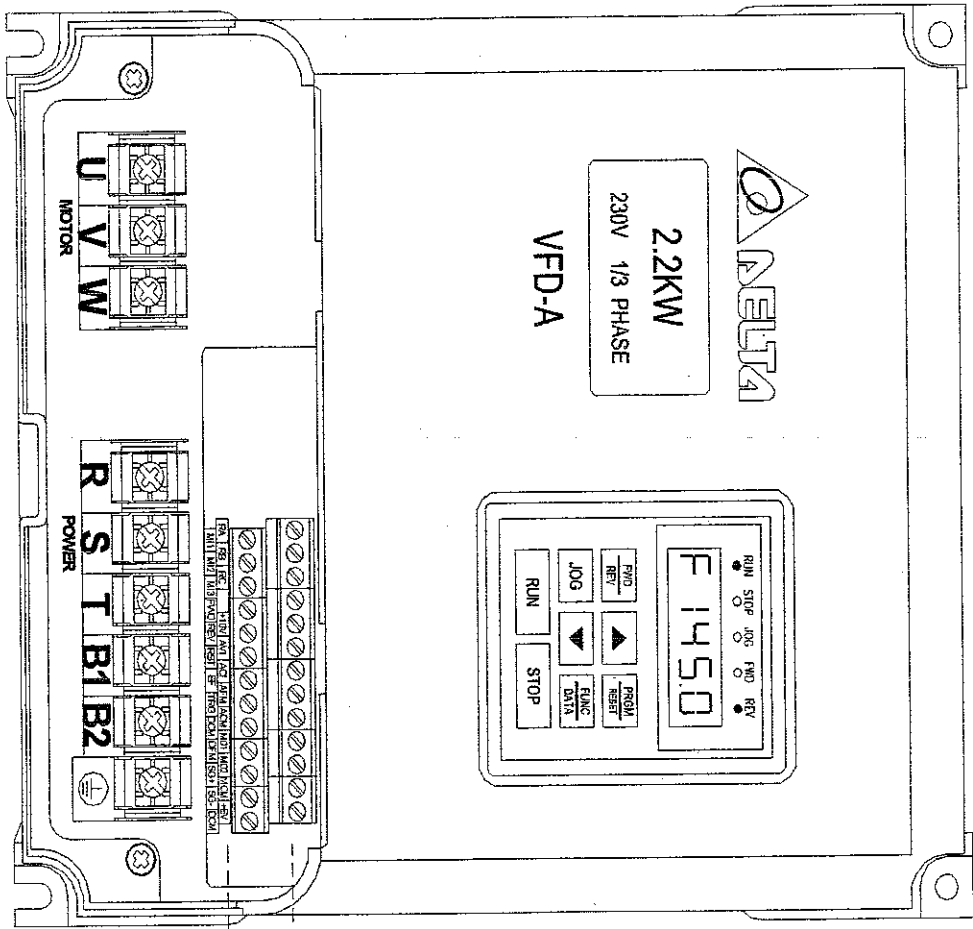
All control terminal voltages will be DC. The negative lead of the voltmeter should be placed on terminal DCM. The D.C. supply of the drive, will vary from +20 to +24 Volts.

Solid circles, on drive display L.E.D.s, indicate that the L.E.D. is illuminated. Circles with four lines protruding, at 45, 135, 225, and 315 degrees (X) indicate that the L.E.D. is blinking.

**VOLTAGE READINGS:**

- M11 (GRN) TO DCM (WHT) = 0 VOLTS
- M12 (BLK) TO DCM (WHT) = 0 VOLTS
- M13 (RED) TO DCM (WHT) = 0 VOLTS
- FWD (BLU) TO DCM (WHT) = 24 VOLTS
- REV (BRN) TO DCM (WHT) = 0 VOLTS





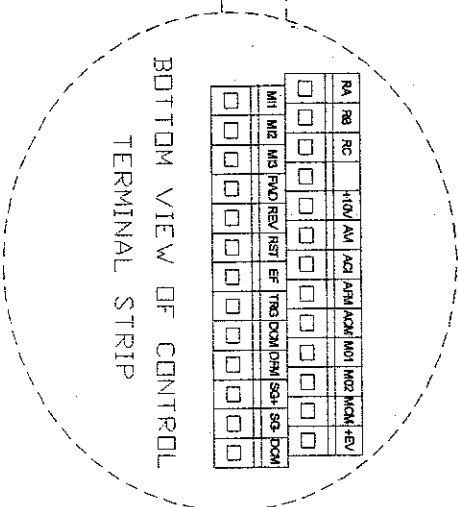
**DRIVE STATUS WITH EXTRACT SIGNAL FROM 100G WASHER CONTROLS.**

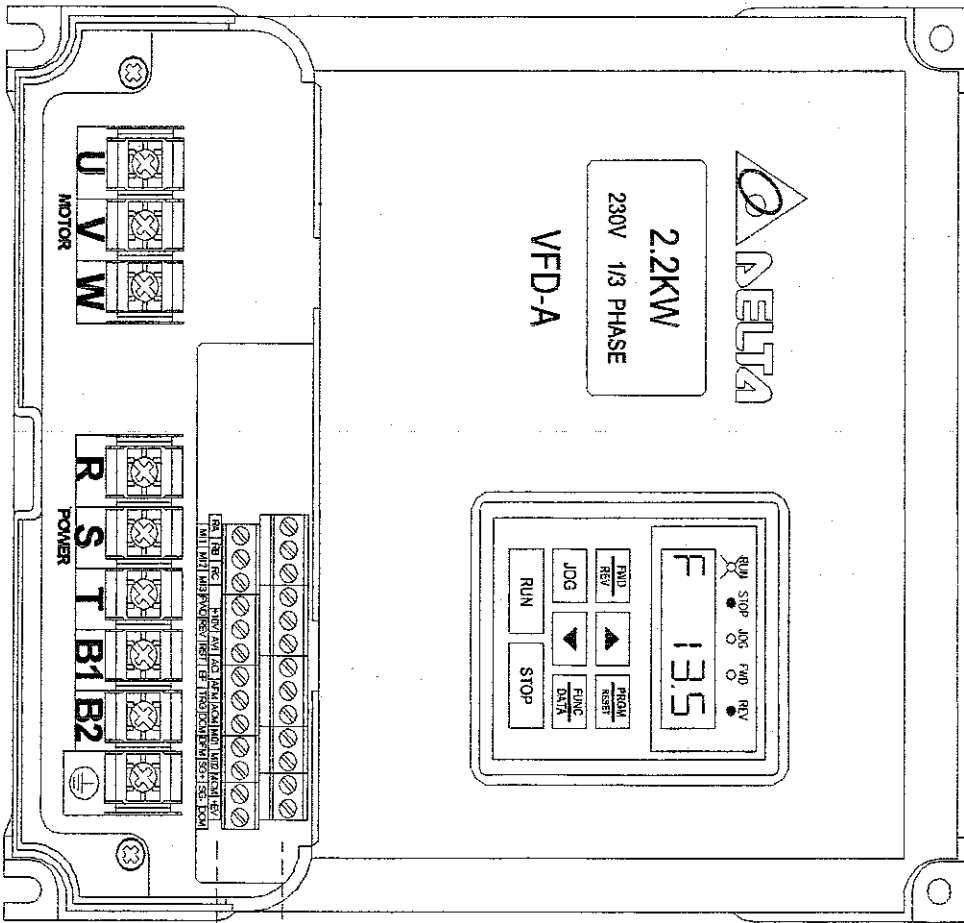
**55# WASHER CONTROL TYPE: MICRO or NON-MICRO**

All control terminal voltages will be DC. The negative lead of the voltmeter should be placed on terminal DCM. The DC supply of the drive will vary from +20 to +24 Volts. Solid circles, on drive display LEDs, indicate that the LED is illuminated. Circles with four lines protruding at 45, 135, 225, and 315 degrees (X) indicate that the LED is blinking.

**VOLTAGE READINGS:**

- M11 (GRN) TO DCM (WHT) = 0 VOLTS
- M12 (BLK) TO DCM (WHT) = 0 VOLTS
- M13 (RED) TO DCM (WHT) = 0 VOLTS
- FWD (BLU) TO DCM (WHT) = 24 VOLTS
- REV (BRN) TO DCM (WHT) = 0 VOLTS





**DRIVE STATUS WHILE DECELERATING FROM EXTRACT SIGNAL FROM WASHER CONTROLS.**

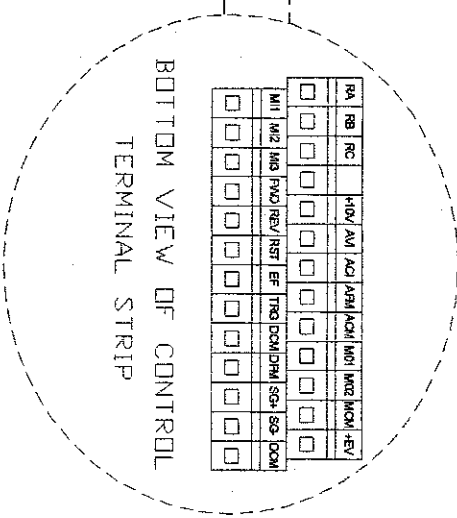
**55# WASHER CONTROL TYPE: MICRO or NON-MICRO**

All control terminal voltages will be D.C. The negative lead of the voltmeter should be placed on terminal DCM. The D.C. supply of the drive will vary from +20 to +24 Volts.

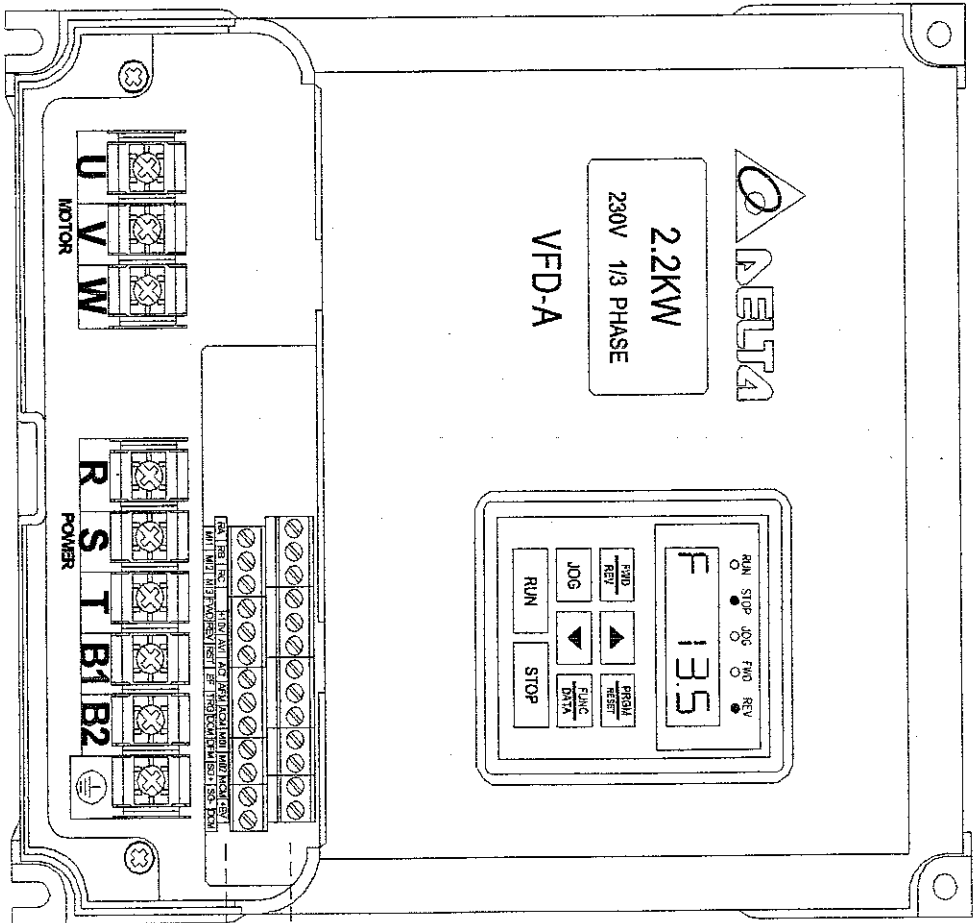
Solid circles, on drive display L.E.D.s, indicate that the L.E.D. is illuminated. Circles with four lines protruding at 45, 135, 225, and 315 degrees (X) indicate that the L.E.D. is blinking.

**VOLTAGE READINGS:**

- M11 (GRN) TO DCM (WHT) = 24 VOLTS
- M12 (BLK) TO DCM (WHT) = 24 VOLTS
- M13 (RED) TO DCM (WHT) = 24 VOLTS
- FV/D (BLU) TO DCM (WHT) = 24 VOLTS
- REV (GRN) TO DCM (WHT) = 24 VOLTS



**BOTTOM VIEW OF CONTROL TERMINAL STRIP**



DRIVE STATUS, AFTER WASHER CYCLE COMPLETE, WITH NO CONTROL SIGNAL FROM WASHER CONTROLS.

55# WASHER CONTROL TYPE: MICRO or RELAY

All control terminal voltages will be D.C. The negative lead of the voltmeter should be placed on terminal DCM. The D.C. supply of the drive will vary from +20 to +24 Volts.

Solid circles, on drive display L.E.D.s, indicate that the L.E.D. is illuminated. Circles with four lines protruding at 45, 135, 225, and 315 degrees (X) indicate that the L.E.D. is blinking.

VOLTAGE READINGS:

- M11 (GRN) TO DCM (WHT) = 24 VOLTS
- M12 (BLK) TO DCM (WHT) = 24 VOLTS
- M13 (RED) TO DCM (WHT) = 24 VOLTS
- FWD (BLU) TO DCM (WHT) = 24 VOLTS
- REV (GRN) TO DCM (WHT) = 24 VOLTS

BOTTOM VIEW OF CONTROL TERMINAL STRIP

RA	RB	RC	+20V/AM	AC1	AM/ACOM	M01	M02	M03	REV
<input type="checkbox"/>	<input type="checkbox"/>	<input type="checkbox"/>	<input type="checkbox"/>	<input type="checkbox"/>	<input type="checkbox"/>	<input type="checkbox"/>	<input type="checkbox"/>	<input type="checkbox"/>	<input type="checkbox"/>
M11	M12	M13	FWD/REV	REV	EF	TRIG	DO/DI	SDM	SDM
<input type="checkbox"/>	<input type="checkbox"/>	<input type="checkbox"/>	<input type="checkbox"/>	<input type="checkbox"/>	<input type="checkbox"/>	<input type="checkbox"/>	<input type="checkbox"/>	<input type="checkbox"/>	<input type="checkbox"/>

# 55lb. Coin Timer Washer Schematic

## WCN55AEK

### Start Circuit

Power travels into the control trough on L1 & L2. 240VAC goes to a Control Transformer that steps the voltage down to 120VAC for the controls. 120VAC then travels thru the 1.5 amp Circuit Breaker and travels on the white/red wire to the Coin Accumulator Transformer where it is stepped down to 12VAC. This 12VAC powers the Coin Accumulator Board via the gray wire. With the board now powered up, the insert coins light will be illuminated and it's ready to count coins. 120VAC is also supplied to the Main Timer Start and On-Off Contacts on the white/red wire. The Start Contact is closed before the machine has been started so 120VAC travels through the Start Contact and is supplied to the Coin Accumulator Board Start Relay. The S4 Coin Switch counts the quarters and sends a signal to the Coin Accumulator Board. When the coin count is satisfied, the Coin Accumulator Board closes the Start Relay and sends a short 120VAC signal on the orange/white wire to the Rapid Advance Timer Motor. This timer motor starts advancing the Main Timer to the preselected starting position. A few seconds after the Coin Accumulator Board sends the start signal to the Rapid Advance Timer Motor, the Coin Accumulator Start Relay opens, the display goes blank and the On-Off Contact in the Main Timer closes to insure that the S1 Door Switch is closed (showing that the door is locked). The On-Off Contact also provides 120VAC to the On Light on the red wire. With the S1 Switch closed the Door Lock Solenoid is now powered with 120VAC via the white/red wire. The Door Lock Solenoid pulls in, locking the door and closing the S2 and S3 Switches. The S2 Switch is a backup to the S1 Switch so that the adjustment on S1 isn't as critical. The S3 Switch provides 120VAC to Timer Contact RA-3 to power the Rapid Advance Motor again and the Main Timer is allowed to advance on to the preselected start position. The blue wire furnishes the neutral for the controls.



## Fill Circuit-Warm

120VAC is supplied to the controls through the S1, S2, and S3 Door Switches. The On Light and the Door Lock Solenoid (discussed in Start Circuit) will remain on throughout the cycle. The Lock Thermoactuator Contact in the Main Timer is closed and provides the neutral side to operate the Thermoactuator. 120VAC is provided to the Lock Thermoactuator on the orange wire from the S3 Door Switch. The Drain Contact in the Main Timer is closed and provides 120VAC to the Drain Valve on the brown/yellow wire which closes the valve. The Wash Contact in the Main Timer is closed and provides 120VAC to the Reversing Timer and the Reversing Timer Motor on the blue/black wire. This will start the Reversing Timer operating which will alternately open and close the Micro Switches that provide the direction of tumble for the wash basket. The Wash Light Contact in the Main Timer is closed and provides 120VAC to the Wash Light. The orange wire coming from the S3 Door Switch provides power to the Wash Water Contact in the Main Timer. 120VAC connects from the Wash Water Contact to the Wash Temperature Contact via an internal timer connection. With 120VAC on the orange wire & neutral on the orange/yellow wire, the Coin Accumulator Board turns on the Time Remaining Light & starts counting down in minutes. (If delay fill kit is installed, time count down is stopped during fill.)

Now a cycle must be selected with the Selector Switch. We'll use Normal Wash. The washer fills the tub through the back of the machine with either one or both the C1 Cold and H1 Hot Water Valves. At the beginning of the cycle, the detergent dispenser flushes the detergent into the tub. This is accomplished with the Wash Dispenser Contact in the Main Timer. 120VAC travels through the closed Wash dispenser Contact and is supplied to the H2 Hot Water Valve Solenoid by the red/orange wire. As the washer fills with water, the Wash Basket will tumble one direction for 19 seconds, pause, and then reverse direction for 19 seconds. 120VAC travels from the Wash Water Timer Contact to the Heavy Duty Contact in the Selector Switch via the white/black wire. 120VAC goes through the closed Heavy Duty Contact in the Selector Switch and energizes the C1 Cold Water Valve Solenoid via the white/orange wire. 120VAC also travels to the closed Wool/Delicate Contact in the Selector Switch. This closed contact provides power to the H1 Hot Water Valve Solenoid via the red/yellow wire. When the water reaches the predetermined level the Pressure Switch moves to the full position and opens the neutral side of the line to the Water Valves. This shuts the Water Valves off. The neutral for the Water Valves & Main Timer Motor is provided through the Pressure Switch. The Main Timer is stopped until the Pressure Switch provides neutral when full level is reached. Neutral for the Main Timer Motor during drain and spin is provided through the Delay Fill Timer Contact.

## **Wash Circuit**

As the washer fills the tub through the back of the machine with either one or both the C1 Cold and H1 Hot Water Valves, the Wash Basket will tumble one direction for 19 seconds, pause, and then reverse direction for 19 seconds. This is accomplished through the use of a Reversing Timer. 120VAC is supplied to the Reversing Timer Motor on the blue/black wire from the Wash Motor Timer Contact in the Main Timer and 120VAC is supplied to the R1 Run Relay any time the door is locked. This R1 Relay closes & provides 24VDC thru the Reversing Timer Wash Micro Switches. The Reversing Timer will alternately open and close the two Wash Micro Switches and provide 24VDC to the FW (forward) or RV (reverse) terminals on the Variable Frequency Drive.

As discussed in Start and Fill, the Lock Thermoactuator, Drain Valve, On Light, and Main Timer Motor (except in fill) are all operating throughout the Wash Cycle.

## **Drain, Rinse 1 & 2, & Final Rinse Circuit**

The Drain Contact on the Main Timer opens removing power to the Drain Valve. The normally-open spring-loaded Drain Valve opens and empties the tub.

For Rinse 1 & 2, the Rinse Light Contact in the Main Timer closes and provides 120VAC to the Rinse Light. The Rinse Water Contact in the Main Timer also closes and provides 120VAC to the C1 Cold Water Solenoid. The tub will fill until the predetermined level is achieved at which time the Pressure Switch Contact will open the neutral side of the line shutting off the C1 Cold Water Solenoid. When the tub is full, the pressure switch also closes a neutral circuit to the M1 Timer Motor and to the orange/yellow wire on the Coin Accumulator Board. This allows the Main Timer to advance only after the tub is full and stalls the time count down on the Coin Accumulator Board during fills.

For the Final Rinse, the Final Rinse Light Contact in the Main Timer closes and provides 120VAC to the Final Rinse Light. Rinse water is the same as in Rinses above.

As discussed in Start and Fill, the Lock Thermoactuator, Drain Valve, On Light, and Main Timer Motor (except in fill) are all operating throughout the Wash Cycle.

## **Intermediate Extract Circuit**

The Wash Contact remains closed and provides 24VDC to the closed Clockwise Micro Switch on the Reversing Timer. 24VDC is then fed to the Counter Clockwise Micro Switch via a jumper wire. 120VAC is then sent to the Delay Spin Micro Switch. The Delay Spin Micro Switch provides 120VAC to the Spin Motor Contact in the Main Timer on the blue/white wire. The Spin Motor Contact is closed for spin and the voltage continues on to the R2 Spin Motor Relay Coil on the red/black wire. With 120VAC to the R2 Spin Motor Relay Coil two things happen. 120VAC is now provided from the orange wire directly to the Relay eliminating the Reversing Timer and the Micro Switches from the circuit.

The second thing that happens when the R2 Relay is closed is that 24VDC is provided from the DCM terminal of the Variable Frequency Drive through the R1 Run Relay through the R2 Spin Relay to terminals MI1 & MI3 on the Drive and the washer spins at intermediate speed.

## **Final Extract Circuit**

Same as Intermediate Extract but adds the R3 Extract Relay. The Main Timer provides 120VAC to the Extract Relay Coil. When this relay closes it provides 24VDC to the MI2 terminal on the Variable Frequency Drive. This means that all 3 terminals MI1, MI2 & MI3 are powered for high spin.

## **Thermoactuator and Shake Out Circuit**

The Lock Thermoactuator Contact in the Main Timer opens removing the neutral to the Thermoactuator approximately 3 minutes before the end of the cycle. This allows the Thermoactuator time to retract by the end of the cycle.

To insure that the Lock Thermoactuator has retracted by the end of the cycle, one minute prior to the end of the cycle, the Unlock Thermoactuator is powered with 120VAC through the Unlock Thermoactuator Contact in the Main Timer.

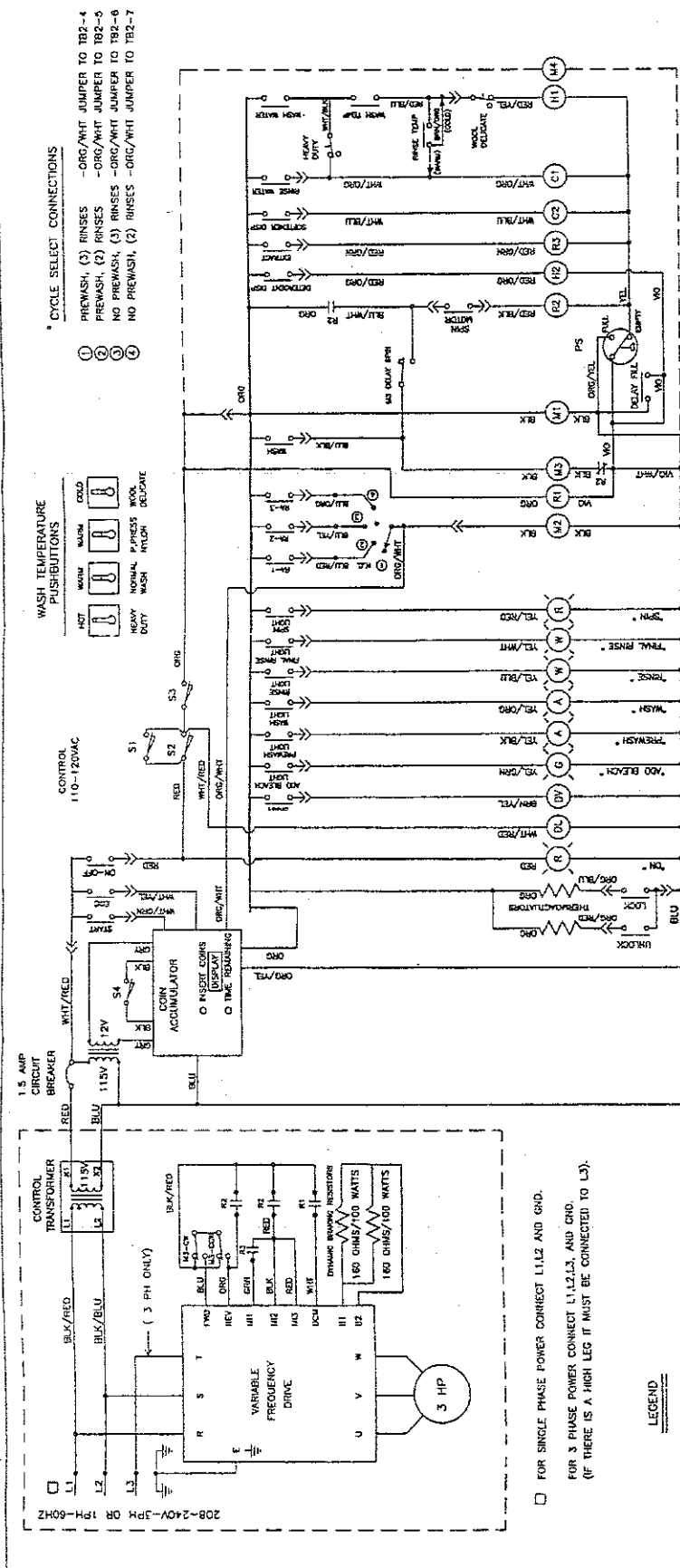
The Spin Motor Contact in the Main Timer opens, stopping voltage to the R2 Spin Motor Relay & the motor. The basket will coast to a stop. The Wash Motor Contact in the Main Timer closes providing power to the Reversing Timer once again (discussed in Wash Cycle). The washer will tumble for approximately 30 seconds to let the clothes shake loose and then stop. The neutral for the Main Timer Motor is provided through the Delay Fill Timer Contact.

### **End of Cycle Circuit**

The On-Off Contact in the Main Timer opens removing power to the Door Lock Switches and Contactors. The machine is now stopped. The Start Contact on the Main Timer is closed providing 120VAC to the Coin Accumulator Board on the white/green wire. The End Of Cycle Contact in the Main Timer is closed sending a 120 volt signal to the Coin Accumulator Board on the white/yellow wire telling it that the cycle is over. This does 2 things:

1. The beeper will signal for 3 seconds letting the user know that it is the end of the cycle.
2. It resets the Coin Accumulator Board and it is now ready to count coins again.

1 2 3 4 5 6 7 8 9 10 11 12



**\* CYCLE SELECT CONNECTIONS**

- ① -ORG/WHT JUMPER TO TB2-4
- ② -ORG/WHT JUMPER TO TB2-5
- ③ -ORG/WHT JUMPER TO TB2-6
- ④ -ORG/WHT JUMPER TO TB2-7

**WASH TEMPERATURE PUSHBUTTONS**

HOT WARM MEDIUM COLD

HEAVY DUTY WASH HEAVY NORMAL PRESSURE WASH DELICATE

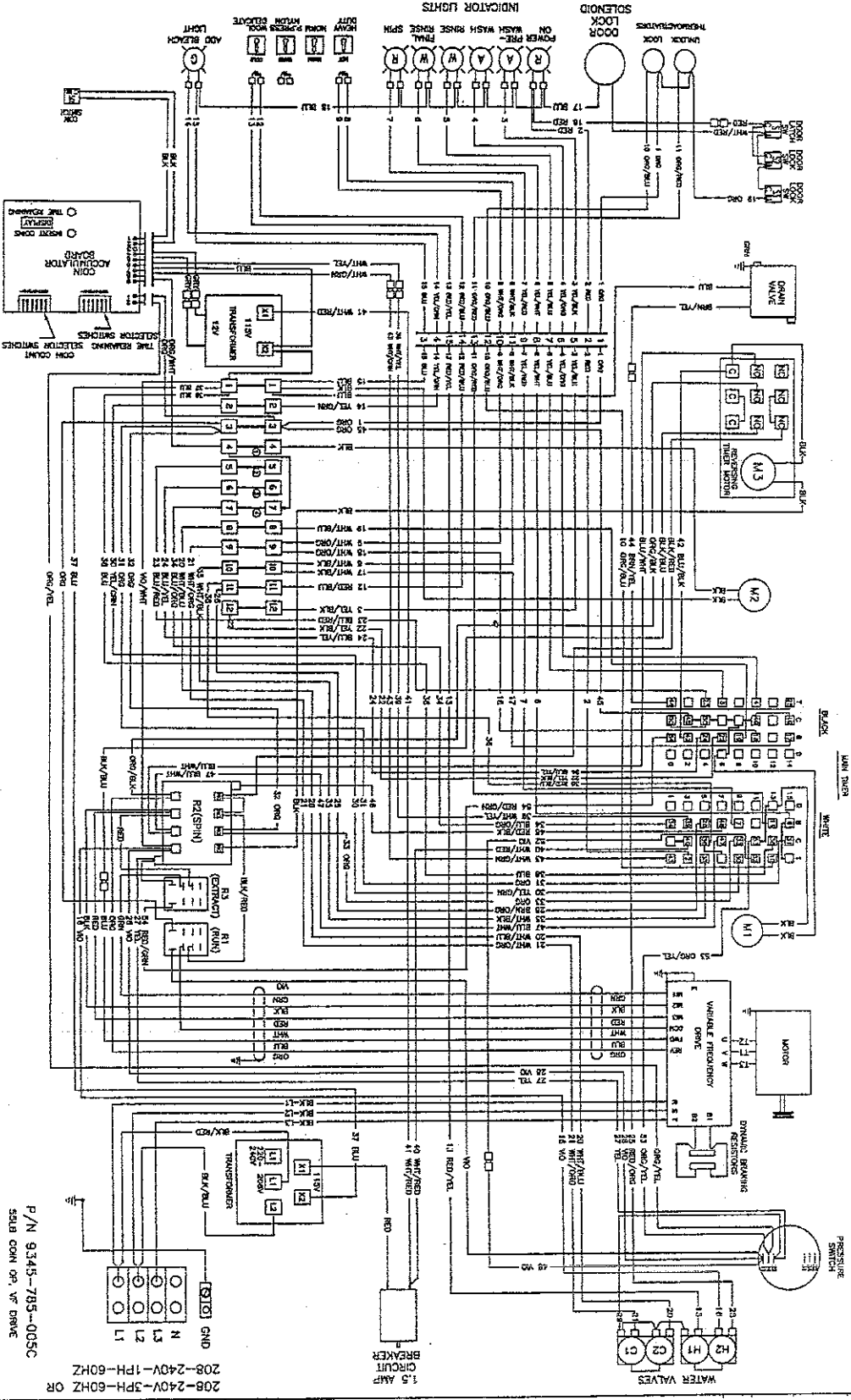
SWITCH FUNCTION	DRY	PREWASH (4 MIN)	WASH (6 MIN)	BLEACH	PREWASH*	WASH	TUMBLE	EXTRACT (44-85SEC)	FINAL RINSE (3M-45SEC)	EXTRACT (44-85SEC)	TUMBLE	OFF
0												
1												
2												
3												
4												
5												
6												
7												
8												
9												
10												
11												
12												
13												
14												
15												

- LEGEND**
- C1 COLD WATER VALVE SOLENOID (TUB)
  - D1 COLD WATER VALVE SOLENOID (SOFTENER DISPENSER)
  - D2 DOOR LOCK SOLENOID
  - D3 DRAIN VALVE
  - H1 HOT WATER VALVE SOLENOID (TUB)
  - H2 HOT WATER VALVE SOLENOID (DETERGENT DISPENSER)
  - M1 MARK TIMER MOTOR
  - M2 RAPID ADVANCE TIMER MOTOR
  - M3 REVERSING TIMER MOTOR
  - M4 ELAPSED TIME METER (OPTIONAL)
  - PS PRESSURE SWITCH
  - R1 RUN RELAY
  - R2 SPIN MOTOR CONTACTOR (CCW)
  - R3 EXTRACT RELAY
  - S1 DOOR SWITCH (DOOR LATCHED)
  - S2 LOCK SWITCH (DOOR LOCKED)
  - S3 LOCK SWITCH (DOOR LOCKED)
  - S4 COIN COUNT SWITCH
  - 0 MAIN TIMER CONTACT
  - 0-9 PUSHBUTTON CONTACT
  - 11 NORMALLY OPEN RELAY CONTACT
  - 12 NORMALLY CLOSED RELAY CONTACT
  - 13 INTERNAL TIMER CONNECTION
  - 14 INDICATOR LIGHT

P/N 9345-782-002C  
55LB COIN OP. VF DRIVE

**WIRING SCHEMATIC 3PH & 1PH, 60HZ**

WIRING DIAGRAM 3PH & 1PH, 60HZ



P/N 9345-755-005C  
 5000 COIN OP. V.F. DRIVE

208-240V-3PH-60HZ OR  
 208-240V-1PH-60HZ

1.5 AMP  
 CIRCUIT  
 BREAKER

# Section 6

## Parts Data

### Thoroughbred 900

#### Accessories

Model **WCN55AEK 208-240 volts 60hz. Single or Three Phase**  
**Mechanical Timer Coin Commercial Washer**

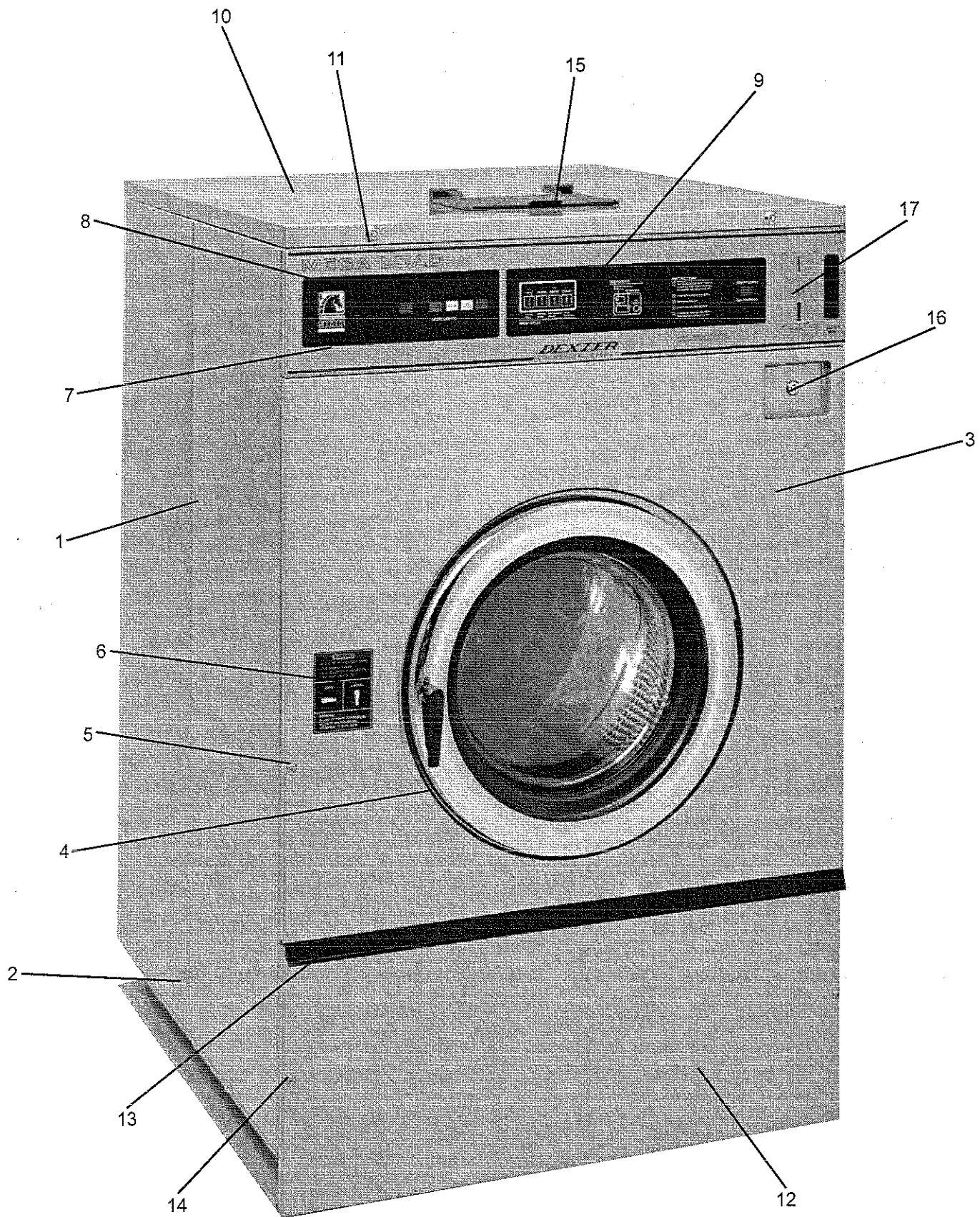
Part Number	Description
9990-027-011	Hose, Water Supply 3/8" I.D. x 48" .....
9990-027-013	Hose, Water supply 5/8" I.D. x 48" (furnished) ..... 2
8641-242-000	Washer, Inlet Hose (furnished) ..... 2
9565-003-001	Strainer, Inlet Hose (furnished) ..... 2
9242-417-001	Drain Hose 10 ft length x 2-1/4" I.D. (optional) .....
9242-417-003	Drain Hose 10 ft length x 3" I.D. (optional) .....
8641-586-002	Bevel Washer for 5/8" bolt used in installations using angle iron bases
8641-586-003	Bevel Washer for 3/4" bolt used in installations using angle iron bases
9732-141-001	Manual Operation Kit
9539-474-001	Switch, Blk/Red (included in kit) ..... 1
9539-474-002	Switch, Blk/Wht (included in kit) ..... 1
8545-051-003	T-10 Torx for removing coin acceptor mounting screws
9732-139-002	Kit, Door Gasket Expander (large) ..... 1
9732-139-001	Kit, Door Gasket Expander (small) ..... 1
8545-055-002	Electrical Probe 100-600 VAC .....
8545-055-001	Electrical Probe 24-90 VAC .....
8538-151-001	Sealing Compound .....
8545-056-001	Special Tool for adjusting spacing between outer tub front and cylinder front
Snap On #CJ-84-C	Puller for pushing cylinder out of bearings

# CABINET AND FRONT PANEL GROUP

Key	Part Number	Description	
1	9454-672-001	Panel ,Side ( Left or Right )- Stainless .....	4
*	9545-018-013	Screw , Side to Side .....	8
*	8640-414-006	Nuts , KEPS .....	8
2	9966-012-001	Strap Assembly, Side Panel .....	4
2	8640-414-006	Nut .....	8
3	9454-671-001	Panel Assy, Front .....	1
4	9059-063-002	Band, Edge Protector .....	1
*	9545-008-024	Screw, Hex- To Control Panel .....	2
*	8640-399-005	Nut, Spring- To Control Panel .....	2
5	9545-008-014	Screw, Flat Head- Front to Sides .....	2
5	8641-585-001	Washer, Finish .....	2
*	8640-399-008	Nut, Spring- To Front Panel .....	2
*	9545-008-023	Screw, Fillister Head Guide .....	2
6	8502-624-002	Label, Door Opening .....	1
7	9989-457-001	Panel, Control (Mounts Nameplate) .....	1
*	9545-008-026	Screw, Hex Wshr- Control Panel to Sides .....	4
8	9412-094-002	Nameplate, Control Panel (one piece) .....	1
8	9412-094-001	Nameplate, Control Panel (two piece)-(old style no time count-down) .....	1
9	8502-629-011	Label, Switch Membrane (used only with #9412-094-001) .....	1
*	9355-001-001	Locator, Panel .....	1
*	9545-008-025	Screw, #10 .....	1
10	9454-673-001	Panel, Top .....	1
11	8650-012-003	Lock, Top (w/Key) .....	2
*	6292-006-007	Key Only, #-6324 .....	1
*	9095-038-001	Cam, Lock Top .....	2
*	8640-426-001	Nut, 9/32 .....	2
*	8641-581-008	Washer, Flat .....	2
12	9108-099-001	Door, Lower Service .....	1
13	9244-081-003	Handle (bumper guard) .....	1
*	9545-045-010	Screw .....	4
*	9545-008-023	Screw, Fillister Head Guide .....	3
14	9545-008-014	Screw, Flat Head .....	2
14	8641-585-001	Washer, Finish .....	2
*	8640-399-008	Nut, Spring .....	2
15	9108-095-003	Door, Dispenser .....	1
*	9451-191-001	Pin, Plain .....	2
*	9467-025-001	Post, Door Mounting .....	2
*	9545-045-002	Screw, Dispenser Post Mtg .....	4
*	9545-008-012	Screw, Dispenser Mounting .....	4
*	8640-399-007	Nut, Spring .....	4
16	9732-122-001	Box Assy, Coin (See Coin Handling Group) .....	1
17	9021-001-010	Acceptor, Coin 25cents (See Coin Handling Group) .....	1

\* Not Illustrated

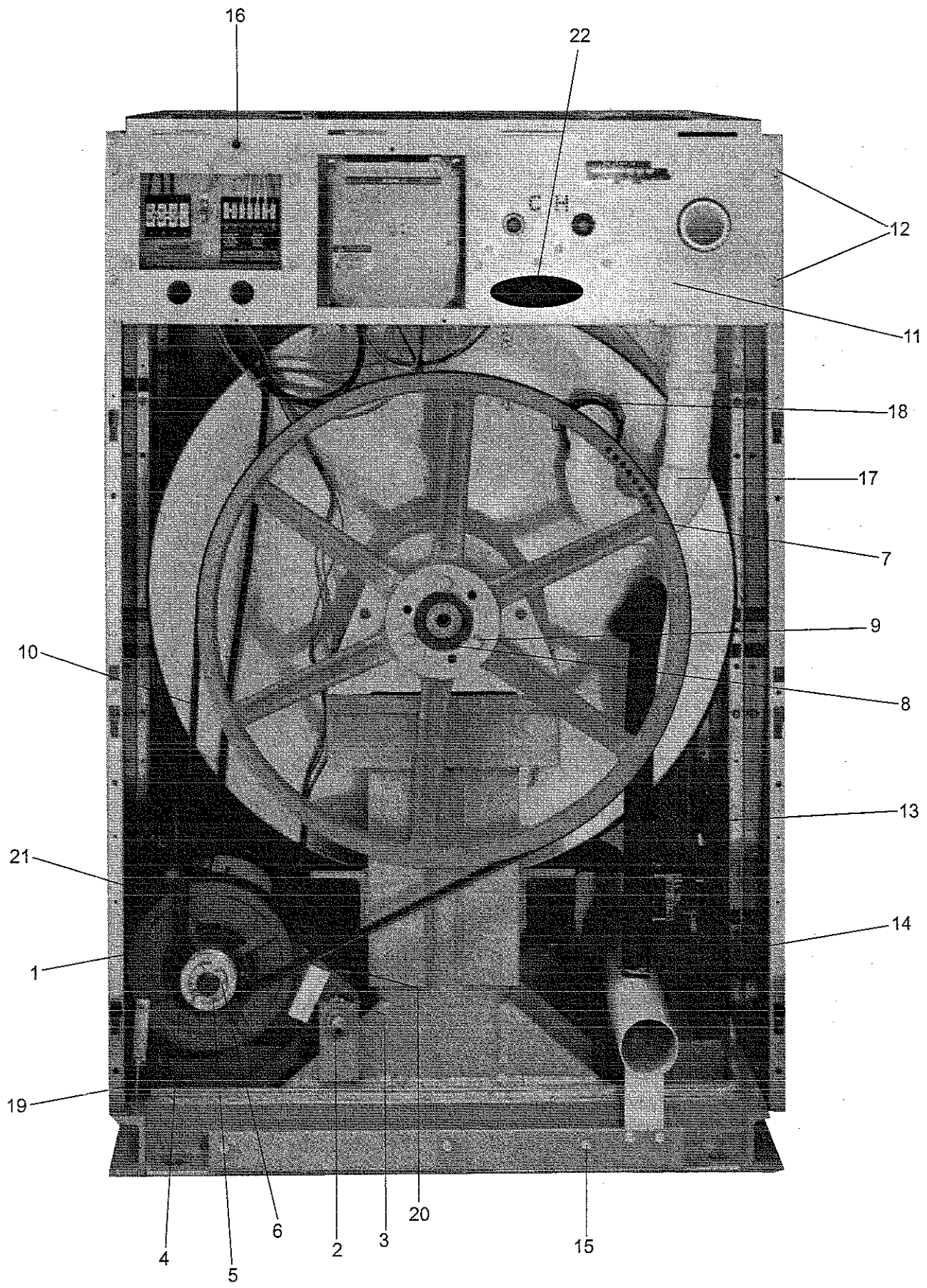




## REAR VIEW

Key	Part Number	Description	
1	9376-298-001	Drive Motor .....	1
2	9497-222-004	Rod, Motor Mtg .....	1
*	9545-029-005	Screw (end of motor rod) .....	1
*	8641-582-014	Lockwasher (end of motor rod) .....	1
3	9076-052-002	Collar, Shaft (w/set screws) .....	2
4	9453-175-002	Pulley, Motor .....	1
5	9053-077-001	Bushing, Split Taper .....	1
6	9545-018-021	Screw .....	3
7	9453-176-001	Pulley, Driven .....	1
8	9053-076-001	Bushing, Taper .....	1
9	9545-029-011	Screw .....	3
9	8641-582-003	Lockwasher .....	3
10	9040-079-002	Drive Belt ( double wide ) .....	1
11	9081-109-001	Channel, Rear .....	1
12	9545-008-005	Screw .....	4
*	8640-399-004	Nut, Spring .....	4
22	9242-449-004	Hose Vent Overflow .....	1
13	9242-449-003	Hose, Overflow .....	1
14	8654-029-000	Clamp, Hose .....	2
*	9989-455-001	Panel Assy., Back .....	1
15	9545-030-002	Screw, To Base .....	4
*	9545-008-026	Screw .....	14
*	8640-399-004	Nut, Spring .....	10
*	9242-175-003	Hose, Pressure Switch .....	1
*	8654-117-015	Clamp, Pressure Sw. Hose .....	1
16	5198-211-004	Circuit Breaker, 1.5 amp .....	1
17	9242-458-003	Hose, Vacuum Brkr. to Tub .....	1
18	8654-117-001	Clamp .....	2
<b>Original Motor Tensioner (not pictured)</b>			
*	9029-027-004	Strap, Motor Tension .....	1
*	8640-413-002	Nut, Strap to Motor .....	1
*	8641-581-006	Washer .....	1
*	9545-018-020	Screw 1/4x3 .....	1
*	8640-414-003	Nut, Elastic Stop .....	1
<b>Current Motor Tensioner (19 thru 21)</b>			
19	9545-055-001	Bolt, Eye .....	1
20	9534-151-000	Spring, Belt Tension .....	1
21	9099-012-003	Chain, Spring Tension .....	1
*	9341-046-001	Link, Chain .....	1
*	8640-414-003	Nut, Stop .....	1
*	8640-413-002	Nut, Link to Motor .....	1
*	8641-581-006	Washer .....	1

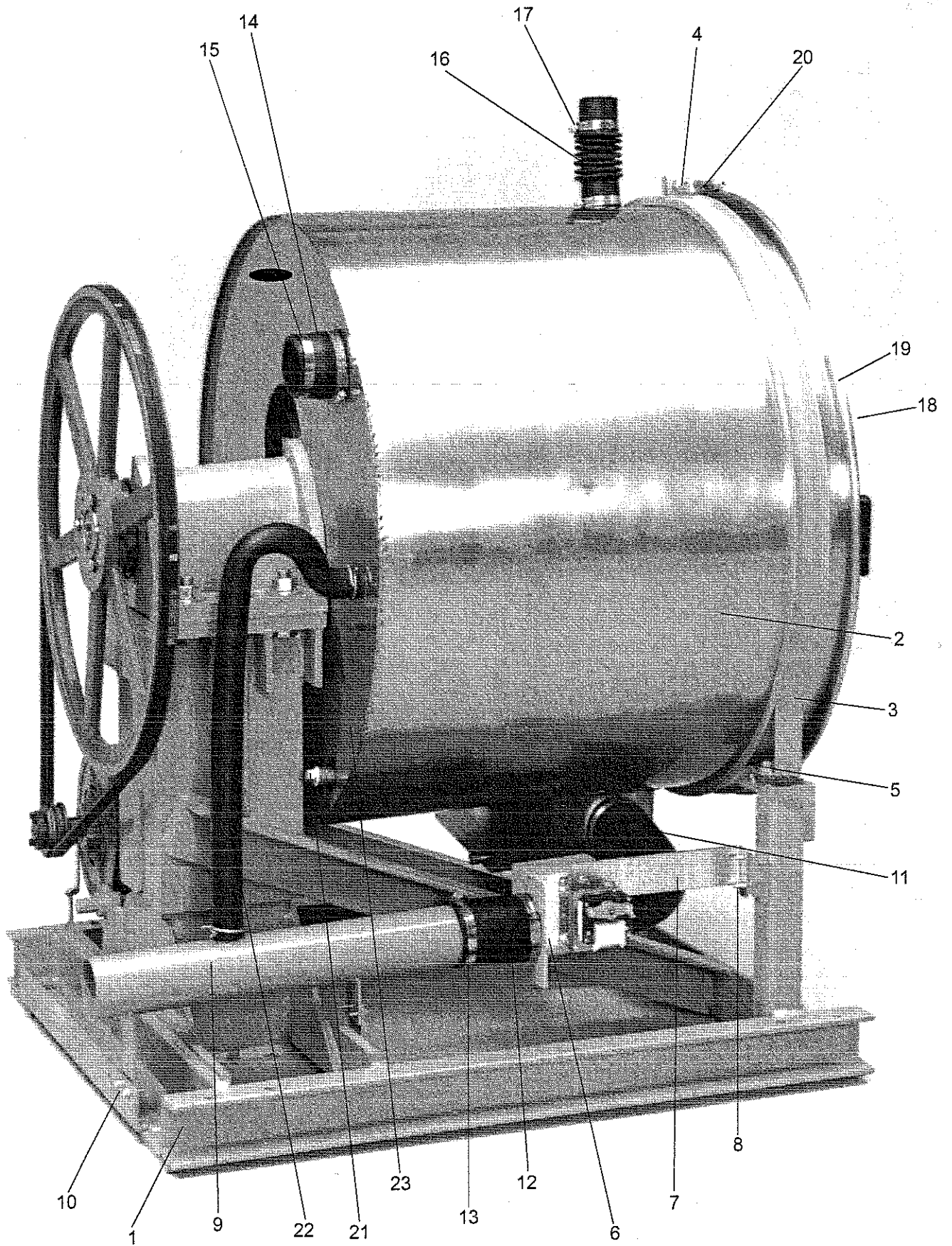
\* Not Illustrated



## CHASSIS AND DRAIN GROUP

Key	Part Number	Description	
1	9945-105-002	Base Assy, Frame .....	1
2	9930-138-001	Tub Assy .....	1
*	9869-009-001	Tub & Cylinder Assembly .....	1
3	9950-053-002	Ring Assy, Tub Mtg-Front .....	1
4	9545-017-013	Screw, 1/2" grade 5 .....	1
4	8640-417-002	Nut .....	1
4	8641-582-016	Lockwasher .....	1
5	9545-017-013	Bolt, 1/2 Grd 5.Tub to Base .....	2
5	8641-582-016	Lockwasher .....	4
5	8640-417-002	Nut, Hex .....	8
5	8641-581-026	Washer, Flat .....	
5	9552-013-001	Shim, Thin .....	AR
5	9552-013-002	Shim, Thick .....	AR
6	9379-187-001	Valve, Drain .....	1
7	9029-070-001	Bracket, Drain Valve .....	1
*	9545-048-001	Screw, Valve to Bracket .....	1
*	8641-581-018	Washer .....	1
8	9545-030-002	Screw, Bracket to Base .....	2
9	9915-120-002	Tube Assy, Drain .....	1
10	9545-030-002	Screw, Tube Mtg .....	4
11	9242-459-001	Hose, Tub to Drain Valve .....	1
12	9242-457-001	Hose, Drain Valve to Tube .....	1
13	8654-117-014	Clamp, Hose .....	4
14	9242-450-001	Hose, Vacuum Brkr. to Tub .....	1
*	9610-001-001	Vacuum Breaker .....	1
*	9029-069-001	Bracket, Vacuum Breaker .....	1
*	9545-008-005	Screw .....	4
15	8654-117-001	Clamp .....	2
*	9732-108-002	Dispenser, .....	1
*	9206-416-001	Gasket, Dispenser .....	1
16	9242-450-001	Hose, Dispenser to Tub .....	1
17	8654-117-008	Clamp, Dispenser Hose .....	2
*	9475-002-002	Flow Restrictors .....	2
18	9974-007-001	Front Ass'y, Tub .....	1
19	9950-055-001	Ring Ass'y, Clamp (tub front to outer tub) .....	1
20	9545-029-009	Screw, 3/8 .....	1
20	8640-415-001	Nut, Hex 3/8 .....	1
*	9206-421-002	Gasket, Tub Front .....	1
21	8615-104-039	Pipe Plug .....	2
22	9242-449-003	Hose, Overflow .....	1
23	8654-029-000	Clamp, Hose .....	2
*	9242-463-004	Overflow hose (suds top) .....	1

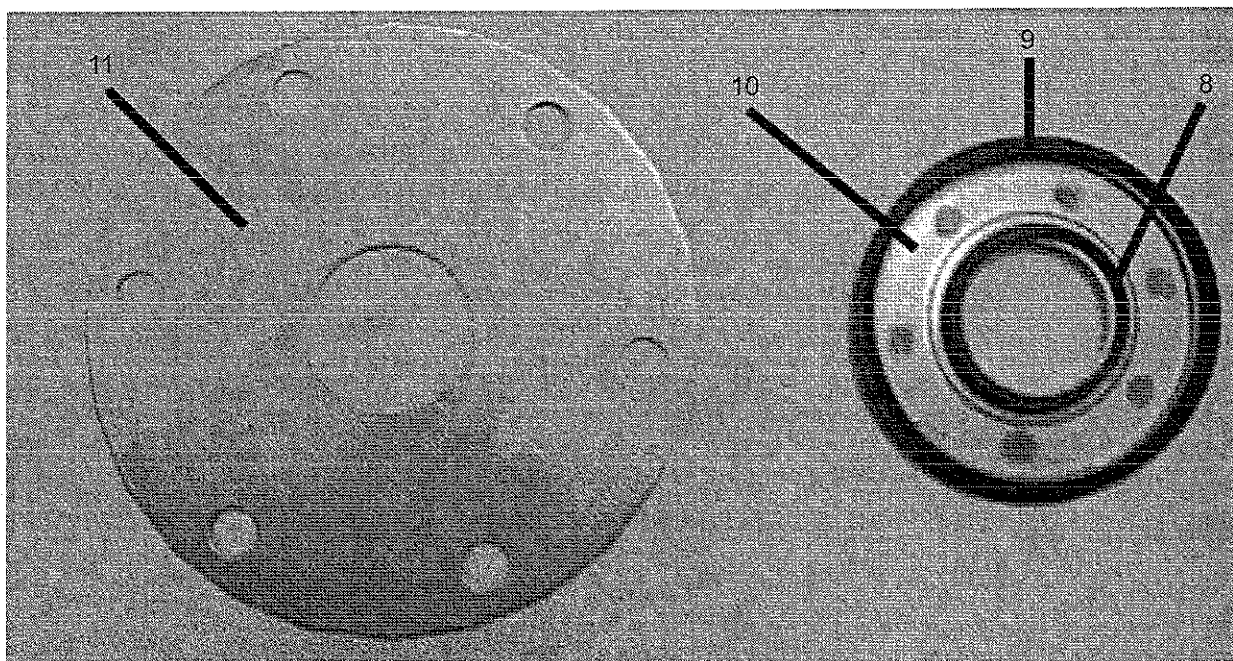
\* Not Illustrated

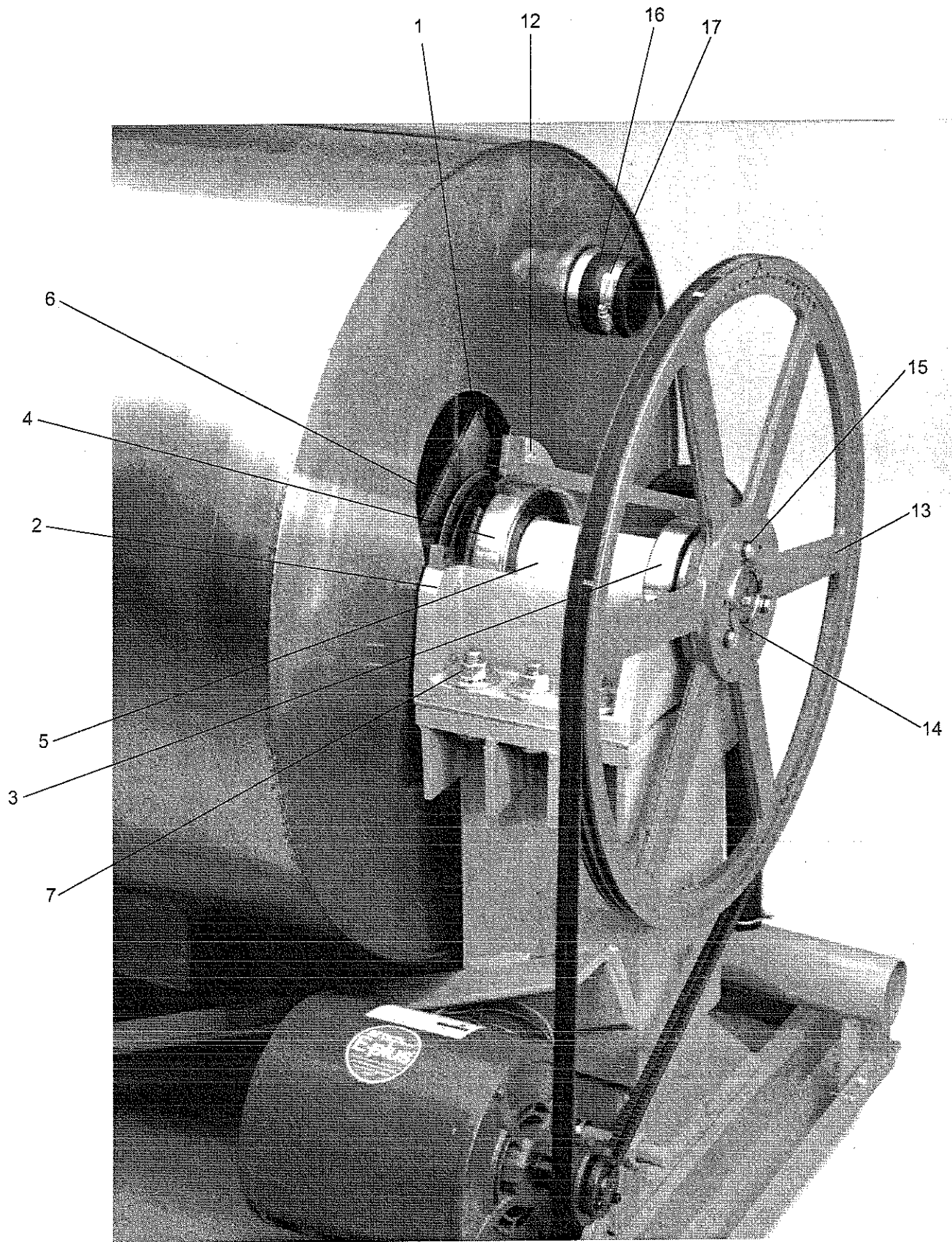


# CYLINDER, WATER SEALS & BEARING HOUSING GROUP

Key	Part Number	Description	
1	9848-116-000	Cylinder, Assy .....	1
*	9456-041-006	Plug , Cylinder ( inside ).....	1
*	9803-187-001	Housing, Bearing- Assembly (includes items #2-#6).....	1
2	9241-181-004	Housing, Bearing .....	1
3	9036-159-006	Bearing, Rear .....	1
4	9036-159-005	Bearing, Front .....	1
5	9538-170-001	Spacer, Bearing .....	1
6	9487-238-004	Ring-Retainer, Internal .....	1
7	9545-057-002	Screw, Bearing Housing to Frame, 3/4 .....	6
7	8641-581-033	Washer, Flat- To Frame .....	6
7	8641-582-020	Washer, External Tooth .....	6
7	8640-418-003	Nut .....	6
8	9532-140-008	Seal, Secondary .....	1
9	9532-140-007	Seal, Primary .....	1
10	9950-052-001	Ring, Seal Mtg .....	1
11	9950-054-004	Ring, Seal Tub Back .....	1
12	9545-059-004	Screw, 7/16 Tub Back to Bearing Housing .....	6
12	8641-581-034	Washer, Flat .....	6
13	9453-176-005	Pulley, Driven .....	1
14	9053-078-002	Bushing, Taper .....	1
15	9545-029-011	Screw .....	3
15	8641-582-003	Lockwasher .....	3
16	9242-450-001	Hose, Vacuum Brkr. to Tub .....	1
17	8654-117-001	Clamp .....	2

\* Not Illustrated



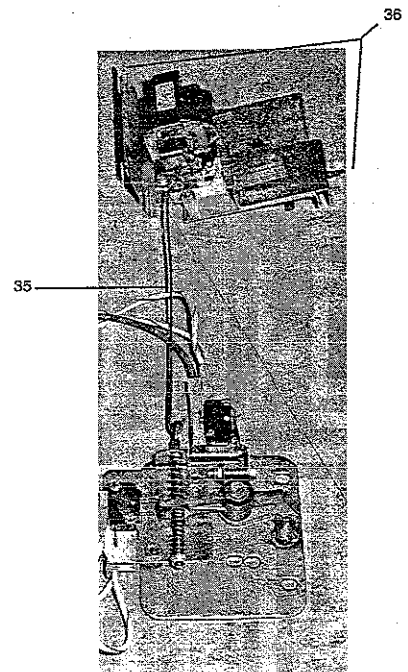
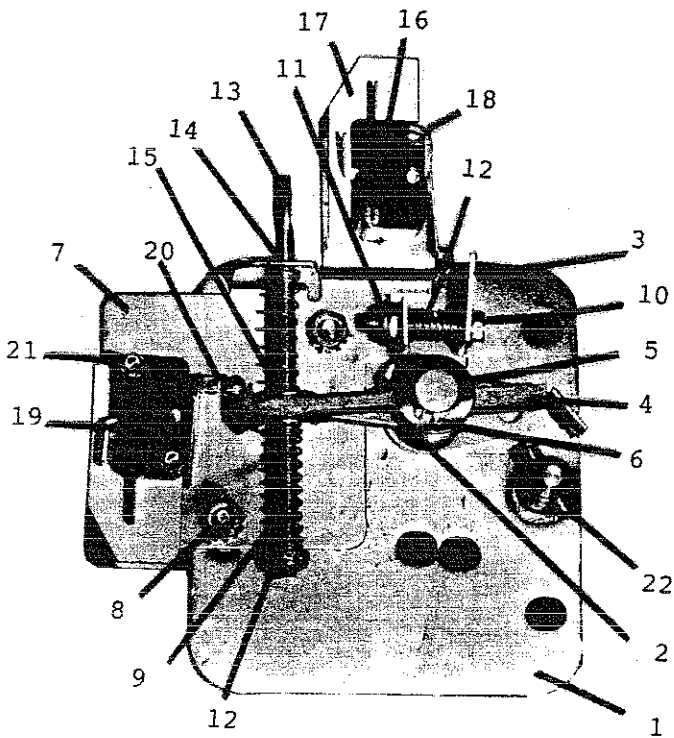
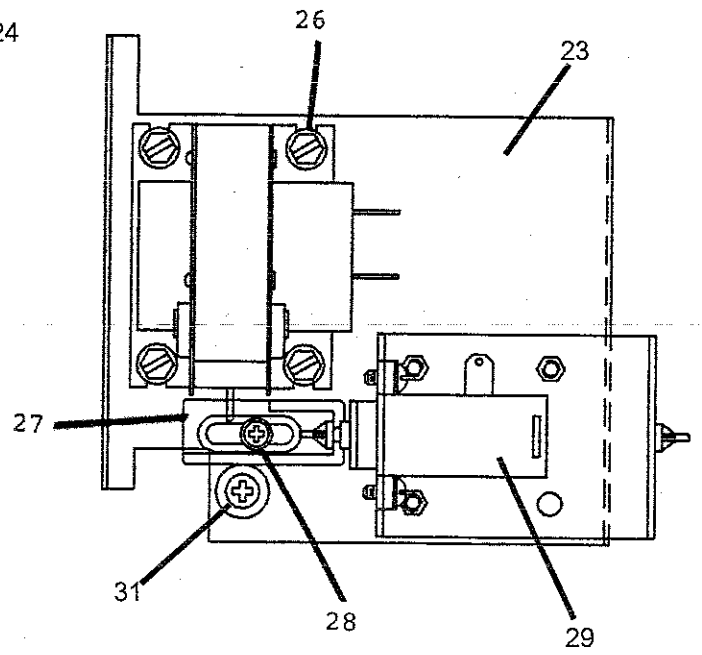
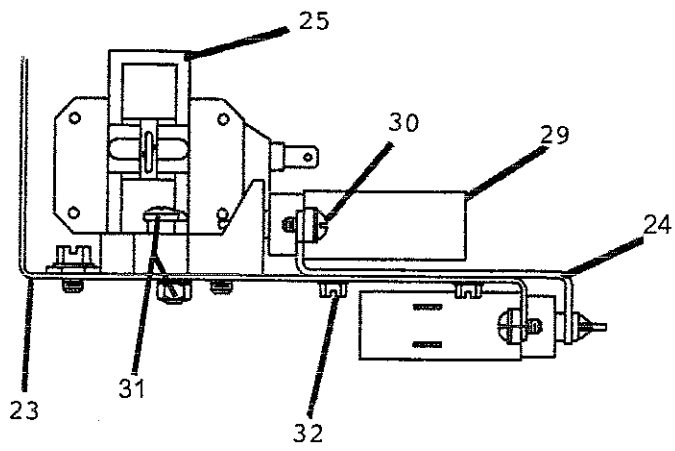


## DOOR LOCK GROUP

Key	Part Number	Description	
*	9885-023-001	Lock Assy, Complete .....	1
1	9982-284-001	Plate Assy, Door Lock .....	1
2	8641-581-030	Washer, Flat .....	1
3	9008-005-001	Actuator, Latching Switch .....	1
4	9450-002-002	Pawl, Locking .....	1
5	8641-569-003	Washer, Spring .....	1
6	9487-200-004	Ring, Retaining .....	1
7	9029-035-001	Bracket, Switch .....	1
8	8640-413-002	Nut, Hex .....	2
9	9534-364-002	Spring, Actuating .....	1
10	9545-012-020	Screw, Hx .....	1
11	8640-413-004	Nut, Elastic Stop .....	2
12	9534-364-001	Spring, Return .....	2
13	9451-193-001	Pin, Guide .....	1
14	9487-200-005	Ring, Retaining .....	1
15	8641-581-031	Washer .....	2
16	9539-461-008	Switch, Latching Sensing .....	1
17	9550-169-003	Shield, Switch .....	3
18	9545-020-001	Screw .....	2
18	8640-401-001	Nut, Twin .....	2
19	9539-461-007	Switch, Locking Sensing .....	2
20	9008-006-002	Actuator, Switch .....	2
21	9545-020-003	Screw .....	2
21	8640-401-001	Nut, Twin .....	1
22	9451-181-004	Pin, Dowel .....	1
*	9552-037-001	Shim, Door Lock, Thin .....	AR
*	9552-037-002	Shim, Door Lock, Thick .....	AR
*	9545-018-014	Screw, Lock mtg .....	3
*	8641-582-007	Lockwasher .....	3
36	9922-011-001	Solenoid Ass'y, Door Locking .....	1
23	9029-073-001	Bracket, Solenoid .....	1
24	9985-169-001	Bracket Assy, Solenoid Slide .....	1
25	9536-074-001	Solenoid .....	1
26	9545-008-001	Screw, Solenoid Mtg .....	4
27	9540-033-002	Stop, Door Lock Solenoid .....	1
28	9545-061-001	Screw, Shoulder .....	1
28	8640-411-003	Nut, Keps #6 .....	1
29	9586-001-001	Thermoactuator .....	2
30	9545-031-004	Screw .....	4
31	9538-157-004	Spacer, Plastic .....	1
31	9538-166-004	Spacer, Metal .....	1
31	9545-010-001	Screw, Cross Recessed .....	1
31	8640-412-005	Nut, Keps #8 .....	1
32	9545-044-003	Screw, Hw #6 .....	3
*	8640-412-005	Nut, Sol. Brkt to Control Panel .....	3
35	9497-225-007	Rod, Pull- Solenoid to Lock .....	1

\* Not Illustrated





## LOADING DOOR GROUP

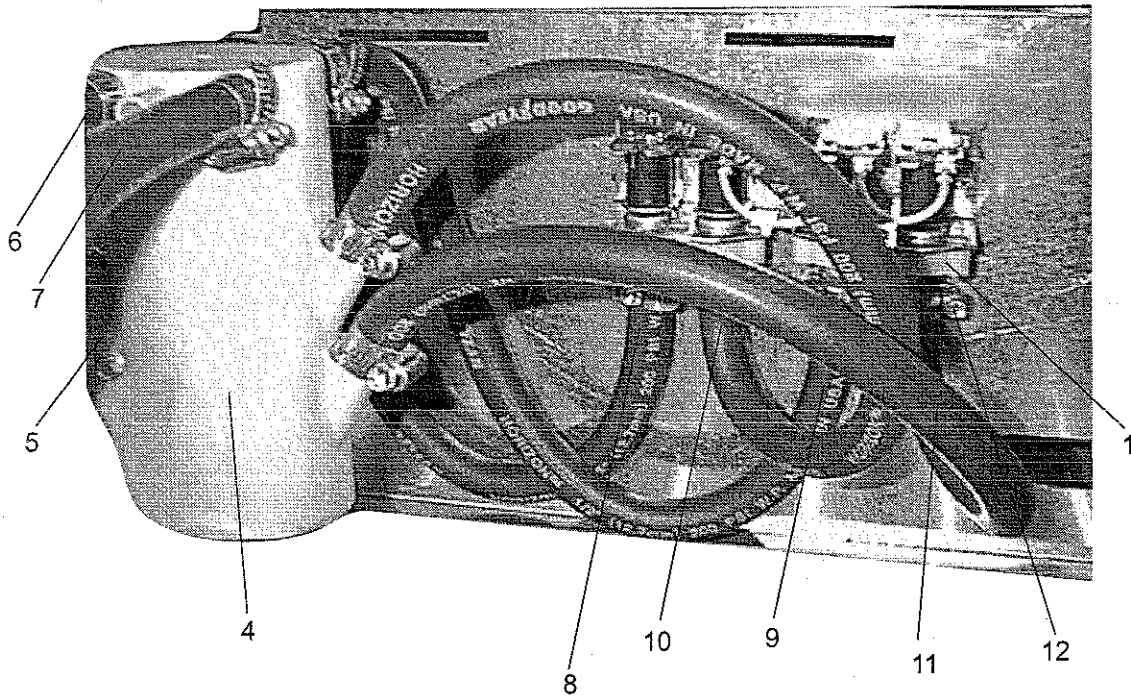
Key	Part Number	Description	
*	9960-274-002	Loading Door, Complete (includes 1 thru 9) .....	1
1	9487-265-001	Loading Door, Ring .....	1
2	9206-419-001	Gasket, Loading Door .....	1
3	9635-016-001	Window, Loading Door .....	1
*	9913-134-003	Shaft Assy, Locking includes (4 thru 7) .....	1
4	9537-195-002	Shaft, Door Locking .....	1
5	9095-040-001	Cam, Locking .....	1
6	9451-181-005	Pin, Groove (1 1/4) .....	1
7	9451-181-004	Pin, Groove (3/4) .....	1
8	9534-360-002	Spring, Lock Cam .....	1
9	9244-080-003	Handle, Door .....	1
*	9451-181-006	Pin, Door Handle (groove) .....	1
10	9955-029-002	Hinge Assy, Loading Door .....	1
*	9545-014-009	Screw, Hinge Mtg .....	3
*	8641-582-009	Lockwasher .....	3
*	9552-036-001	Shim, Loading Door Hinge, Thin .....	AR
*	9552-036-002	Shim, Loading Door Hinge, Thick .....	AR
11	9451-184-004	Pin, Loading Door Hinge .....	1
*	8649-031-000	Ring, Retaining .....	1
12	9079-122-002	Clamp, Loading Door Hinge Pin .....	1
13	9545-056-001	Screw, Loading Door Mtg .....	3
14	9487-254-001	Ring, Masking .....	1
*	9059-063-002	Band, Edge .....	1
*	8640-413-002	Nut, Keps .....	4

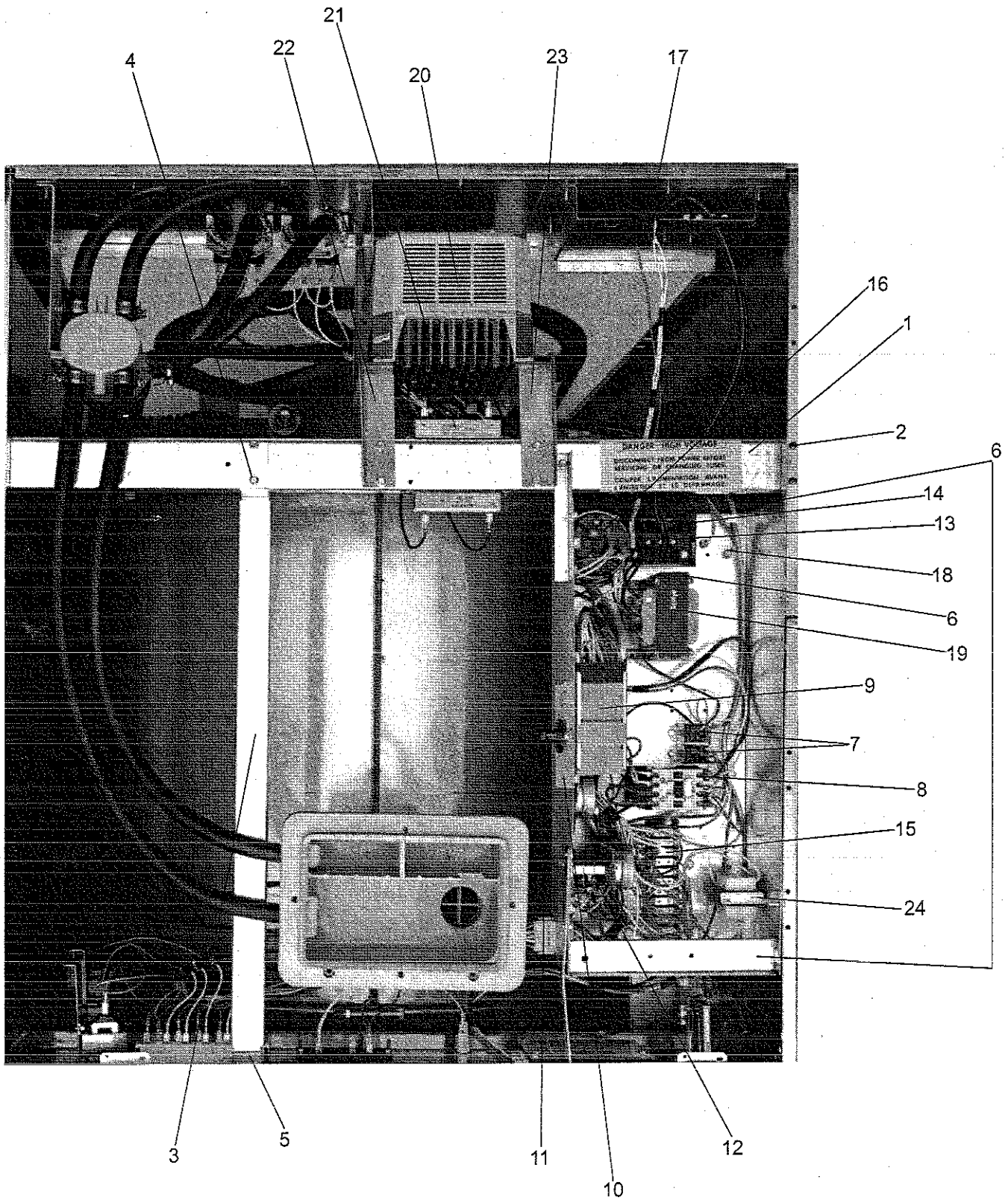
\* Not Illustrated

# WATER INLET GROUP

Key	Part Number	Description	
1	9379-183-003	Valve, Water Inlet.....	2
		(see Water Inlet Valve Breakdown for individual parts)	
*	9545-008-026	Screw, Valve Mtg .....	4
*	8640-399-009	Nut, Spring .....	4
*	9208-049-001	Guard, Water Valve .....	1
*	9545-008-026	Screw .....	2
4	9610-001-001	Vacuum Breaker .....	1
*	9029-069-001	Bracket, Vacuum Breaker .....	1
5	9545-008-026	Screw .....	4
*	9242-458-003	Hose, Vacuum Breaker to Tub-Ribbed .....	1
*	8654-117-014	Clamp, Vac Brkr End .....	1
*	8654-117-009	Clamp, Tub End .....	1
6	9242-453-018	Hose, Vac. Brkr. to Wash Dis .....	1
7	9242-453-019	Hose, Vac. Brkr. to Rinse Dis .....	1
8	9242-453-015	Hose, Hot Valve to Vac. Brkr .....	1
9	9242-453-007	Hose, Cold Valve to Vac. Brkr .....	1
10	9242-453-015	Hose, Hot Valve to Tub .....	1
11	9242-453-007	Hose, Cold to Tub .....	1
12	8654-117-015	Clamp, Hose-Worm .....	12
*	5198-211-004	Circuit Breaker .....	1

\* Not Illustrated





# ELECTRICAL COMPONENTS TOP COMPARTMENT

Key	Part Number	Description	
1	9081-110-001	Channel, Trough Mtg .....	1
2	9545-008-023	Screws .....	2
3	9081-108-001	Channel, Dispenser Support .....	1
4	9545-008-026	Screw .....	2
5	9545-008-001	Screw, To Cntrl Panel .....	2
6	9839-013-001	Trough Assy, Controls Mtg .....	1
*	9545-008-005	Screw .....	4
7	5192-285-001	Relay, Run & Extract .....	2
8	5192-295-004	Relay, Spin .....	1
9	9571-362-001	Timer, Program .....	1
		(VERIFY PART NUMBER ON TIMER BODY)	
*	9376-295-002	Motor, Timer Main Drive .....	1
*	9376-286-004	Motor, Timer Rapid Advance .....	1
*	9545-012-001	Screw, Timer Mtg .....	2
10	9107-068-001	Dial, Timer .....	1
11	9307-176-001	Knob, Timer (w/set screws) .....	1
*	9538-157-006	Spacer, Knob .....	1
12	9571-360-001	Timer, Reversing .....	1
*	9545-044-004	Screw, Reversing Timer .....	2
13	9897-033-002	Terminal Block, 3 Position Power Connection .....	1
14	9558-025-001	Strip, Terminal Marker .....	1
*	9545-031-010	Screw, Mtg .....	2
15	9897-029-001	Terminal Block Assy, 12 Position .....	1
*	9558-021-001	Strip, Terminal Marker .....	1
*	9545-045-007	Screw, Mtg .....	2
16	9539-488-001	Switch, Pressure .....	1
*	9545-031-003	Screw .....	1
*	9029-071-001	Bracket, Pressure Switch .....	1
*	9545-045-001	Screw, Mtg .....	2
17	5198-211-004	Circuit Breaker, 1.5 amp .....	1
18	8652-134-001	Lug, Grounding .....	1
*	8639-621-007	Screw, Mtg .....	1
*	8641-582-006	Lockwasher .....	1
19	8711-004-001	Transformer, Control .....	1
*	9545-008-026	Screw .....	1
*	8641-582-006	Lockwasher .....	1
20	9375-003-003	Drive, VF-100G DELTA BRAND <i>9732-237-001</i> .....	1
21	9483-004-003	Resistor, Braking 160 OHM .....	2
*	9545-012-003	Screw .....	4
*	8640-413-002	Nut .....	4
22	9029-115-001	Bracket, Drive Mtg for DELTA .....	1
*		Bracket	
*	9545-008-026	Screw .....	6
24	8711-003-001	Transformer, 12VAC for Coin Accumulator .....	1
*	9545-003-001	Screw, Transformer Mtg .....	2

\* Not Illustrated

# COIN HANDLING GROUP

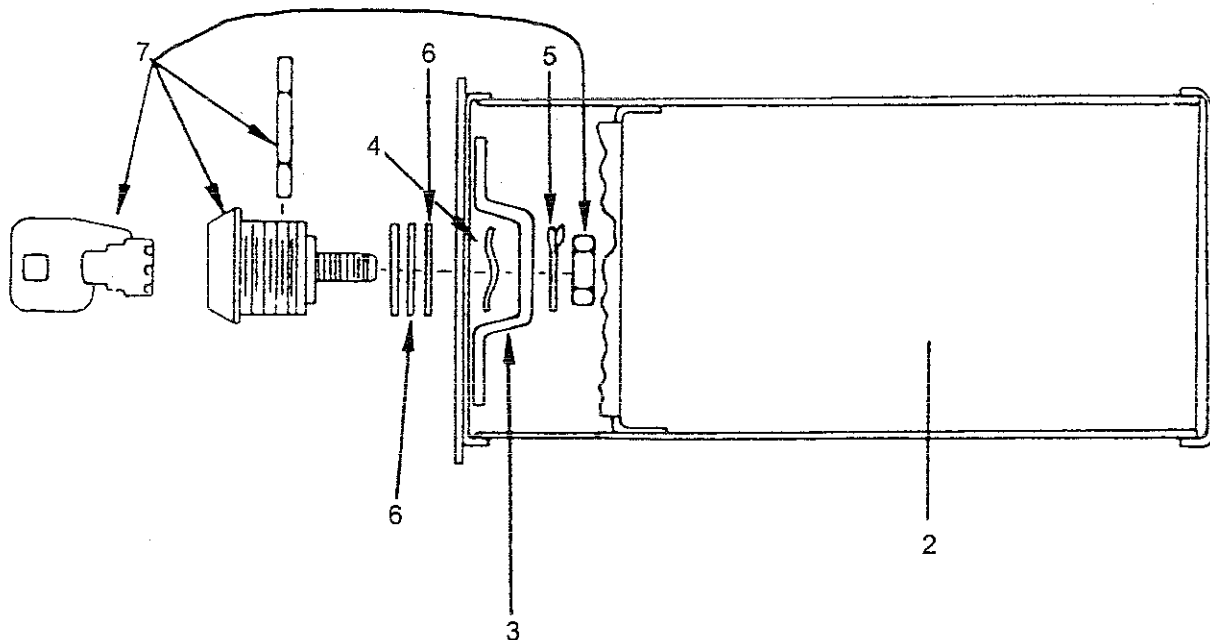
Key	Part Number	Description	
1	9942-026-006	Vault, Assy .....	1
*	9545-008-026	Screw, Vault Mtg .....	4

NOTE: COIN BOX AND HARDWARE KIT AND COIN BOX LOCK NOT INCLUDED WITH MACHINE.

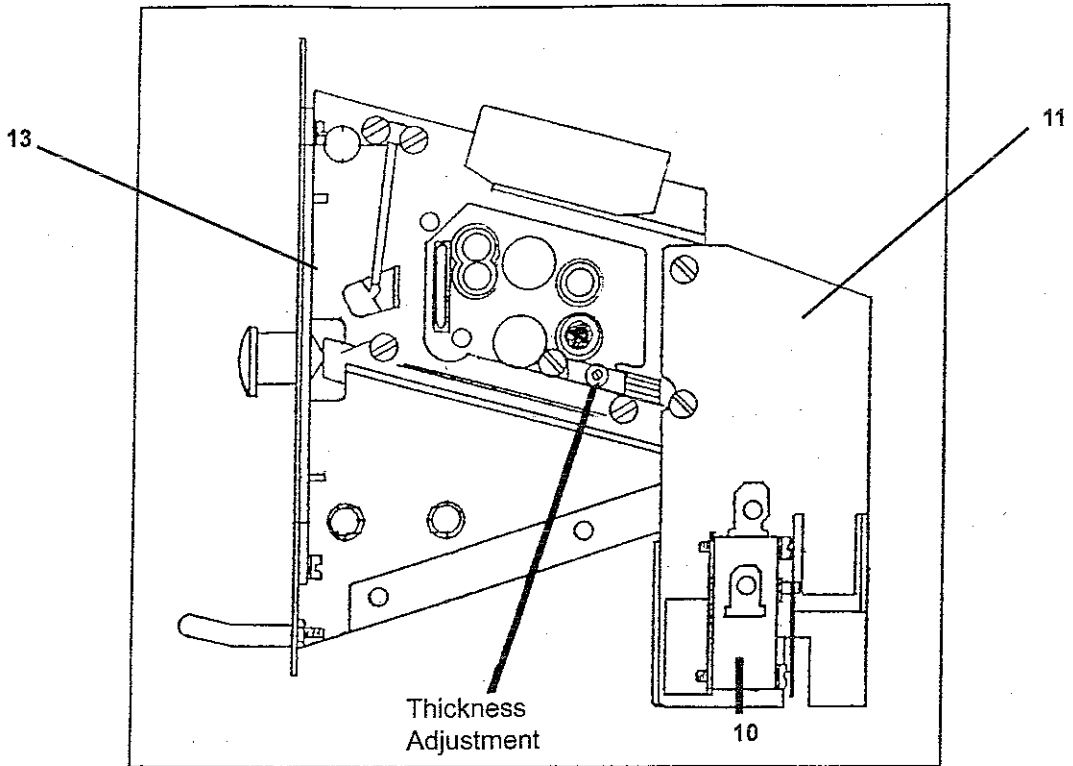
2	9732-122-001	Kit, Coin Box W/Hardware(key not included with 9732-122-001) .	1
3	9349-033-001	Latch, Coin Box .....	1
4	8641-569-002	Washer, Wave .....	1
5	8641-583-001	Washer, Keeper .....	1
6	8641-581-008	Washer, Spacer- Thick .....	2
6	8641-581-010	Washer, Spacer- Thin .....	4
Lock, Key, Nuts for Coin Box			
7	8650-012-002	Lock, Coin Box (key not included with #9732-122-001) .....	1
*	9940-014-004	Chute Assy., Coin to Vault.....	1
*	9545-008-001	Screw, Chute Mtg .....	1
9	9021-001-010	Acceptor, Coin .....	1
*	9545-020-004	Screw, Acceptor Mtg .....	4
*	8640-424-002	Nut .....	4
10	9732-126-001	Switch, Coin .....	1
11	9119-025-002	Acceptor Chute Assembly without penny reject(standard) .....	1
12	9119-025-001	Acceptor Chute Assembly with penny rejector (optional) .....	1
13	9486-133-001	Button Coin Return Retainer .....	1

\* Not Illustrated

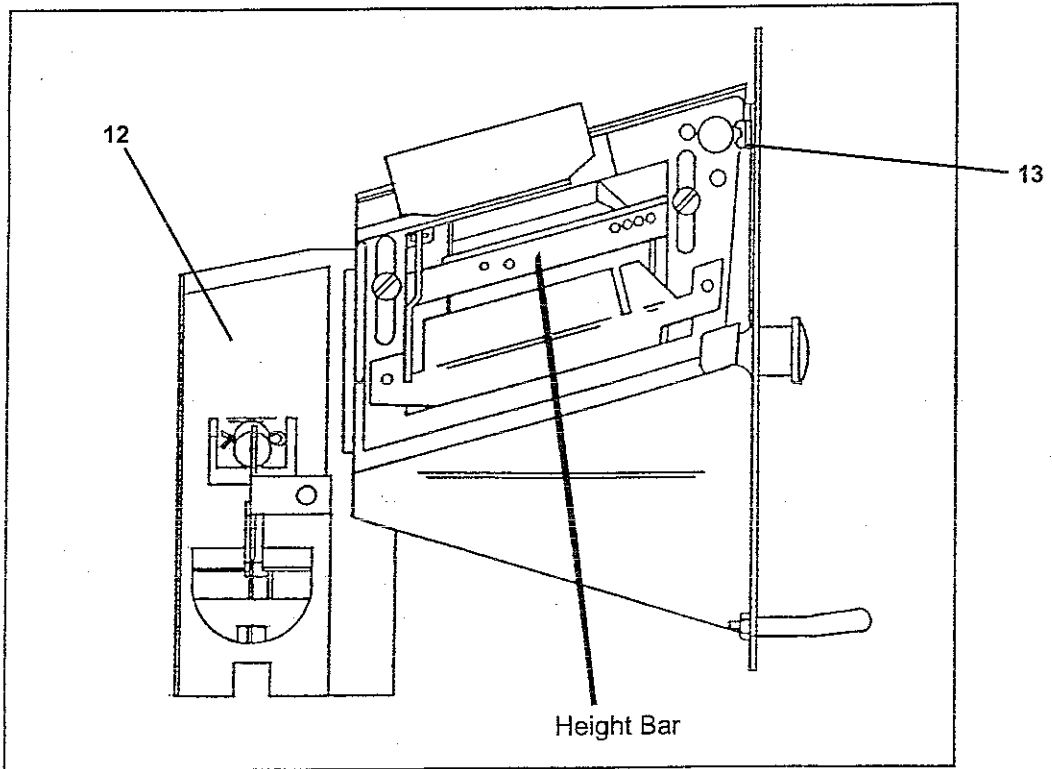
Coin Acceptor From Manual



Coin Handling Group



#9 COIN ACCEPTOR - right side

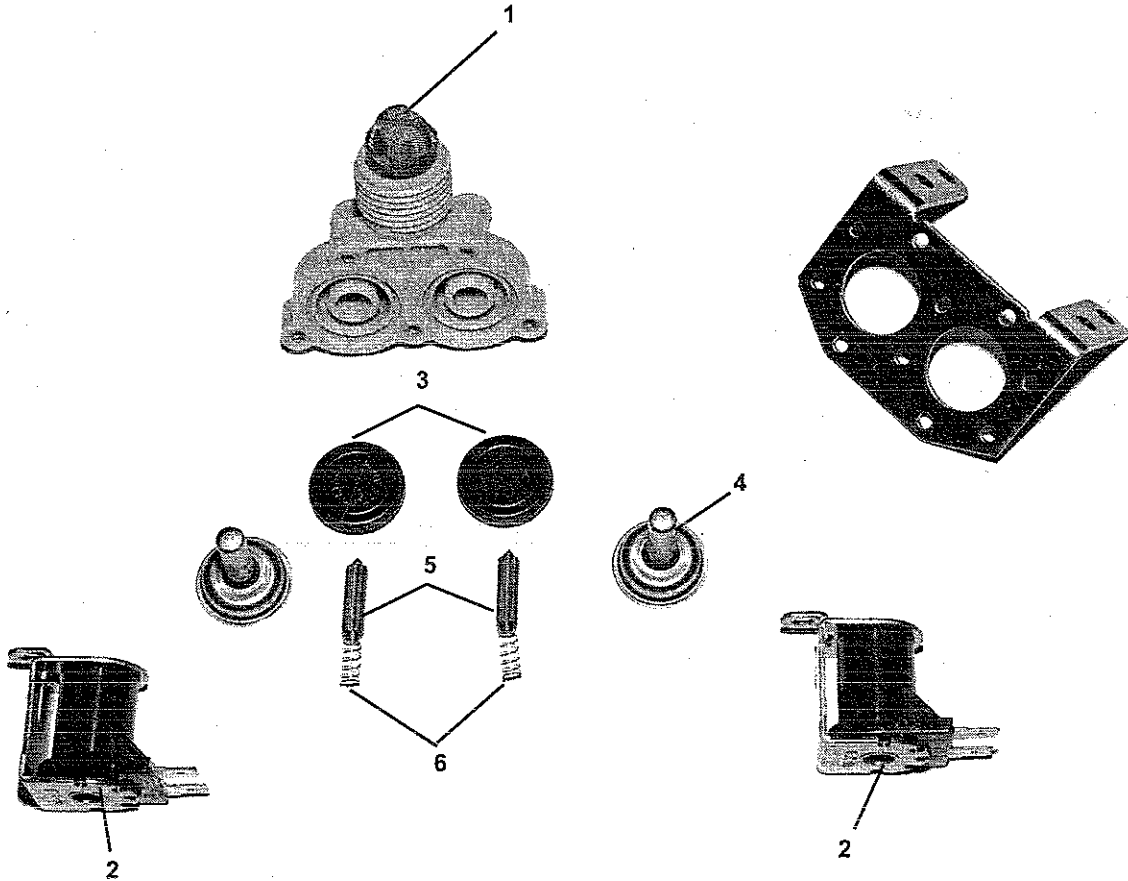


#9 COIN ACCEPTOR - left side

# WATER INLET VALVE BREAKDOWN

Key	Part Number	Description	
	9379-183-003	Valve, Water Inlet Blue (includes #1 thru #6) .....	2
1	9555-056-001	Screen, Inlet .....	2
2	9089-017-001	Coil Assy., 120 V .....	2
3	9118-049-001	Diaphragm .....	2
*	9118-049-002	Diaphragm (chemical resistant optional) .....	
4	9211-021-002	Guide, Solenoid .....	2
5	9015-008-001	Armature .....	2
6	9534-298-001	Spring, Armature .....	2
*	9545-008-026	Screw, Valve Mtg .....	2

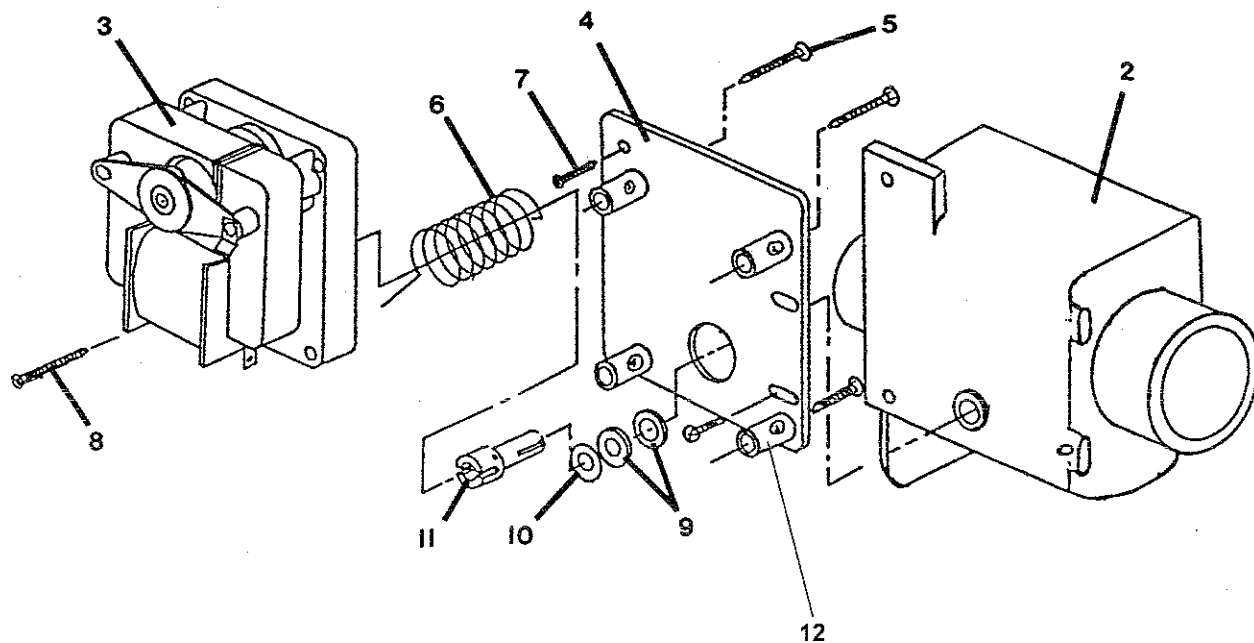
\* Not Illustrated





# DRAIN VALVE GROUP

Key	Part Number	Description	
1	9379-187-001	Valve, Drain .....	1
2	9064-070-001	Body, Valve (w/ball).....	1
3	9914-137-001	Motor & Gear Train .....	1
4	9452-538-001	Plate, Motor Mtg .....	1
5	8639-994-001	Screw .....	3
6	9534-339-001	Spring, Drive .....	1
7	9545-054-001	Screw .....	2
8	9545-054-002	Screw .....	1
9	9532-134-001	Seal, V Packer .....	2
10	8641-584-001	Washer .....	1
11	9451-196-001	Pin, Main Drive .....	1
12	9538-149-001	Plate , ( spacers needed for replacement motor mtg. plate)	4



## TERMINAL BLOCKS

Key	Part Number	Description	
*	9897-029-001	Terminal Block, 12 Position .....	1
*	9558-021-001	Terminal Marker Strip .....	1
*	9545-045-007	Screw .....	2
*	9897-028-001	Terminal Block, 3 Position .....	1
*	9558-022-001	Terminal Marker Strip .....	1
*	9545-045-007	Screw .....	2
*	9897-033-001	Terminal Block, 4 Position .....	1
*	9558-025-001	Terminal Marker Strip .....	1
*	9545-031-010	Screw .....	2
*	8652-134-001	Terminal Lug, Ground .....	1
*	8639-621-007	Screw .....	1
*	8641-582-006	Lockwasher .....	1
*	8652-130-037	Terminal, Grounding .....	1
*	8639-621-007	Screw .....	1
*	9544-041-002	Lockwasher .....	1

## LABELS

*	8502-624-002	Label, Warning Door Opening .....	1
*	8502-614-004	Label, High Voltage .....	1
*	8502-639-001	Label, Warning- Copper Wiring .....	1
*	8502-649-002	Label, Connections- Electrical .....	1
*	8502-619-004	Label, Fusing & Installation .....	1

## WIRING HARNESS GROUP

Key	Part Number	Description	
*	9627-747-001	Wiring Harness, Power Term Blk .....	1
*	9627-710-001	Wiring Harness, VF Power Drive .....	1
*	9627-695-001	Wiring Harness, Main .....	1
*	9627-689-001	Wiring Harness, Control .....	1
*	9627-693-001	Wiring Harness, VF Control Shield .....	1
*	9627-683-001	Wiring Harness, Drain Valve .....	1
*	9627-708-001	Wiring Harness, Countdown .....	1
*	8654-125-005	Clamp, Cable- 1/4 Dia .....	2

\* Not Illustrated

# Section 7

## Preventive Maintenance

### Daily

1. Clean the top and the cabinet to remove residue.
2. Clean the soap dispenser and soap lid.
3. Check the drain for leaking and proper draining.
4. Check the loading door for leaks.
5. Clean the door seal of all foreign material.
6. Leave the loading door open to aerate the washer when not in use.

### Quarterly

**Make sure the power is disconnected before making the following checks.**

1. Check the drive belt for wear and proper tension.
2. Clean lint and other foreign material from around drive motor.
3. Check all water connections for leaks.
4. Wipe and clean the inside of the washer and check all electrical components for moisture and dust.
5. Remove and clean water inlet hose filters. Replace if necessary.
6. After any service always replace all panels before reconnecting electrical power.

