

# THE DEXTER COMPANY

## COIN OPERATED MICRO CONTROLLED V-SERIES

WCVD-18, WCVD-25, WCVD-40, WCVD-55, WCVD-75

### SERVICE PROCEDURES AND PARTS DATA

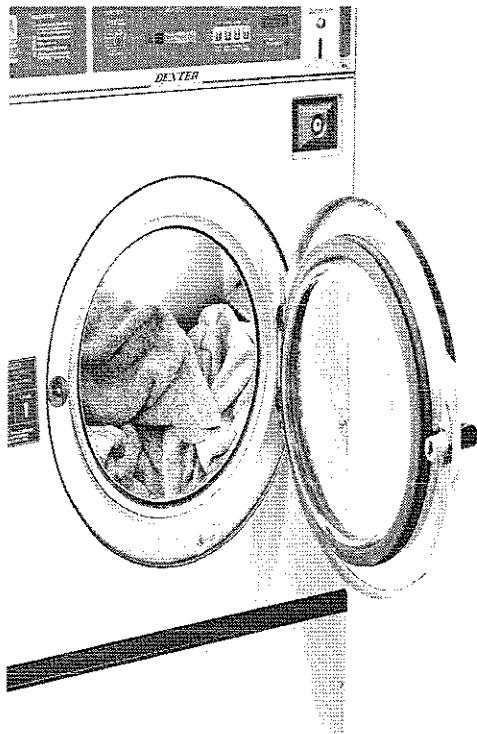

FAIRFIELD, IOWA 52556

641-472-5131

PART NUMBER # 8533-050-001

FAX. 641-472-6336

12/04

# Table of Contents

## SECTION 1

Specifications .....	page 7-15
V-300 mounting dimension sheet .....	page 8
V-400 mounting dimension sheet.....	page 7
V-600 mounting dimension sheet .....	page 10
V-900 mounting dimension sheet .....	page 9
V-1200 mounting dimension sheet .....	page 11
Water Usage Chart .....	page 12
Proper Mounting Procedures .....	page 18-21
V-300 mounting detail .....	
V-400 mounting detail .....	
V-600 mounting detail .....	
V-800 mounting detail .....	
V-1200 mounting detail .....	

## SECTION 2

Installation & Operation .....	page 16
Foundation Requirements .....	page 22
Plumbing .....	page 22
Electrical .....	page 23
Controls Transformer .....	page 23
Rotation A .....	page 22
Schematics and Wiring diagrams .....	page 26-35
Programming .....	page 36-40
Operating Instructions and Detergent Chart.....	page 41

## SECTION 3

Operational wiring schematics text .....	page 42-44
Start Circuit .....	page 42
Fill Circuit-Warm .....	page 43
Wash Circuit .....	page 43
Drain, Rinse 1 & 2, & Final Rinse Circuit .....	page 43
Extract Circuit .....	page 44
Thermoactuator and Shake Out Circuit .....	page 44
End of Cycle Circuit .....	page 44
.....	

Loading Door .....	page
Loading Door Hinge .....	page
Back Panel .....	page
Drive Belt .....	page
Drive Motor .....	page
Control Panel Name Plate .....	page
Tub Back, Bearing and Cylinder (basket) Assembly .....	page
Bolt Torque Chart .....	page
Basket Pulley .....	page
Bearing Housing, Water Seals and Tub Back .....	page
Outer Tub .....	page
Cabinet .....	page

## SECTION 5

Trouble Shooting .....	page
------------------------	------

## SECTION 6

Parts Data .....	page
Accessories .....	page
Cabinet and Front Panel Group .....	page
Rear View .....	page
Chassis and Drain Group .....	page
Cylinder, Water Seals & Bearing Housing Group .....	page
Door Lock Group .....	page
Loading Door Group .....	page
Control Panel Group .....	page
Water Inlet Group .....	page
Electrical Components - Top Compartment .....	page
Coin Handling Group .....	page
Water Inlet Valve Breakdown .....	page
Drain Valve Group .....	page
Wiring Harness Group .....	page 6

# Section 2

Model	Voltage		
WCVD18KCS-10	120	volt	60hz Single Phase
WCVD18KCS-12	208-240	volt	60hz Single Phase and ThreePhase
WCVD25KCS-12	208-240	volt	60hz Single Phase and Three Phase
WCVD40KCS-12	208-240	volt	60hz Single Phase and Three Phase
WCVD55KCS-12	208-240	volt	60hz Single Phase and Three Phase
WCVD75KCS-12	208-240	volt	60hz Single Phase and Three Phase

400 SERIES COMMERCIAL WASHER  
MOUNTING DIMENSIONS

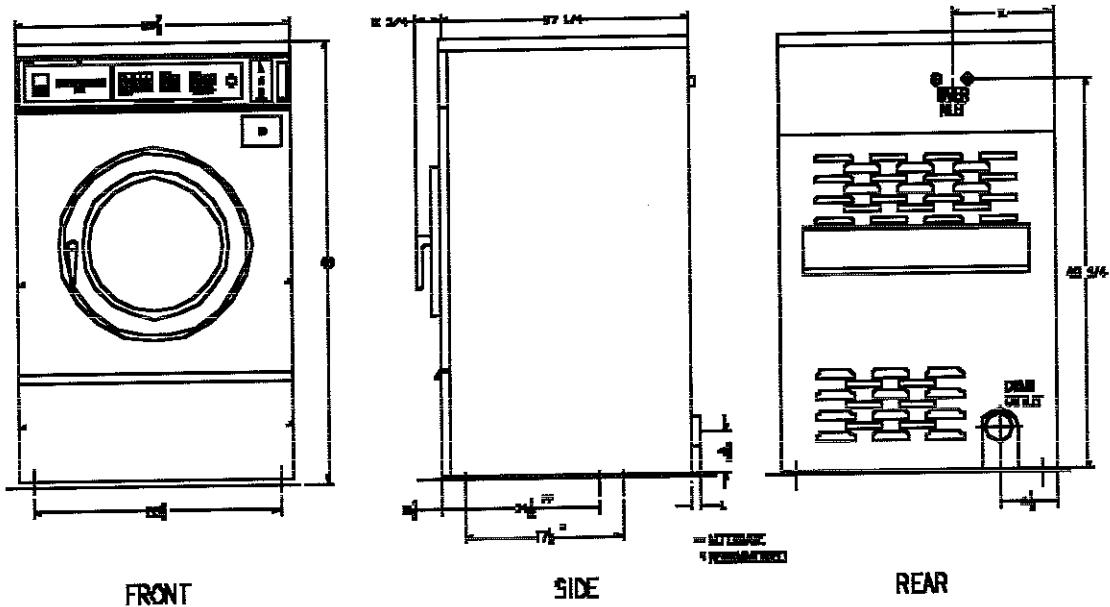

900 SERIES COMMERCIAL WASHER  
MOUNTING DIMENSIONS

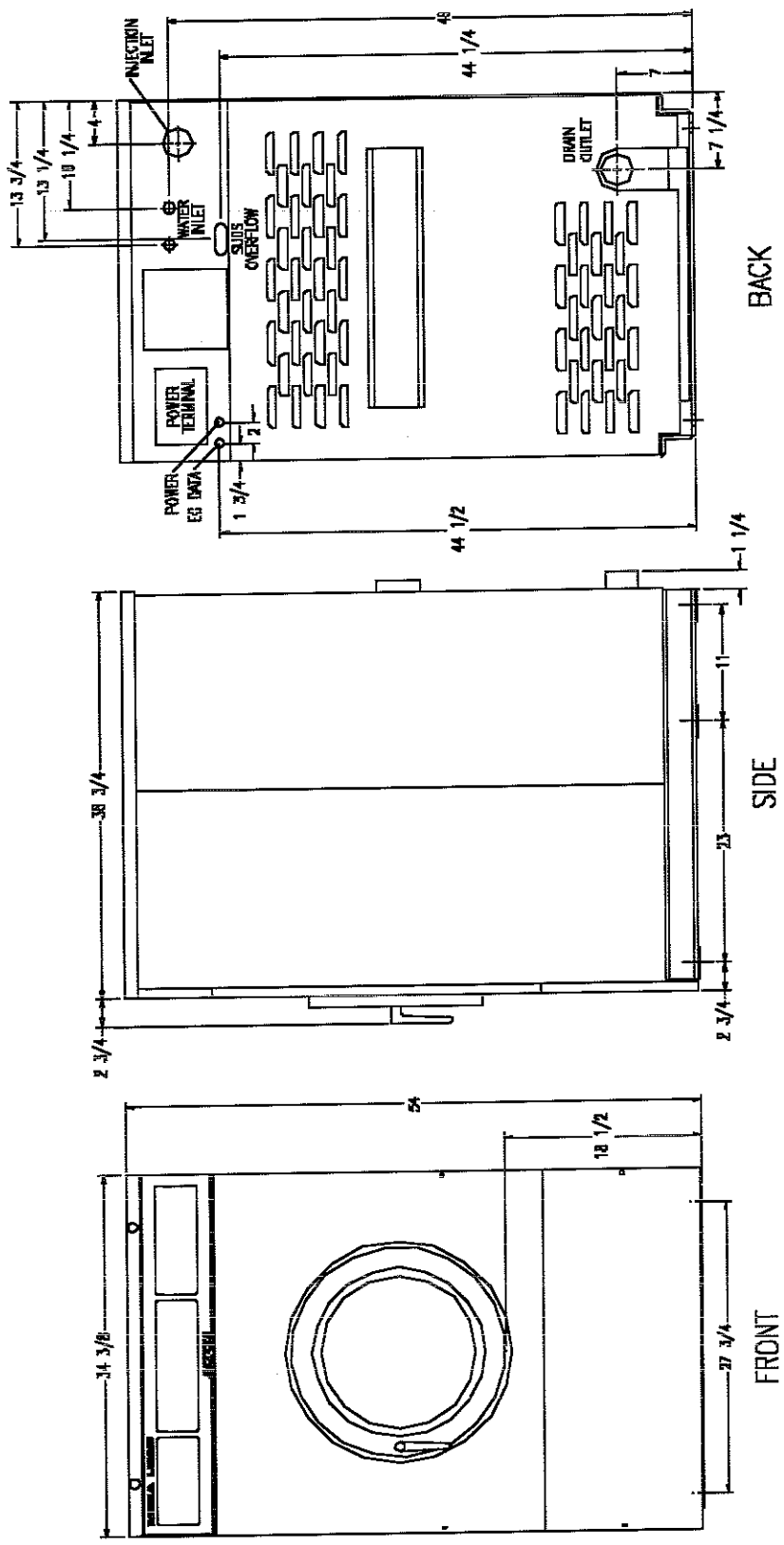

# 1200 SERIES COMMERCIAL WASHER DIMENSIONS

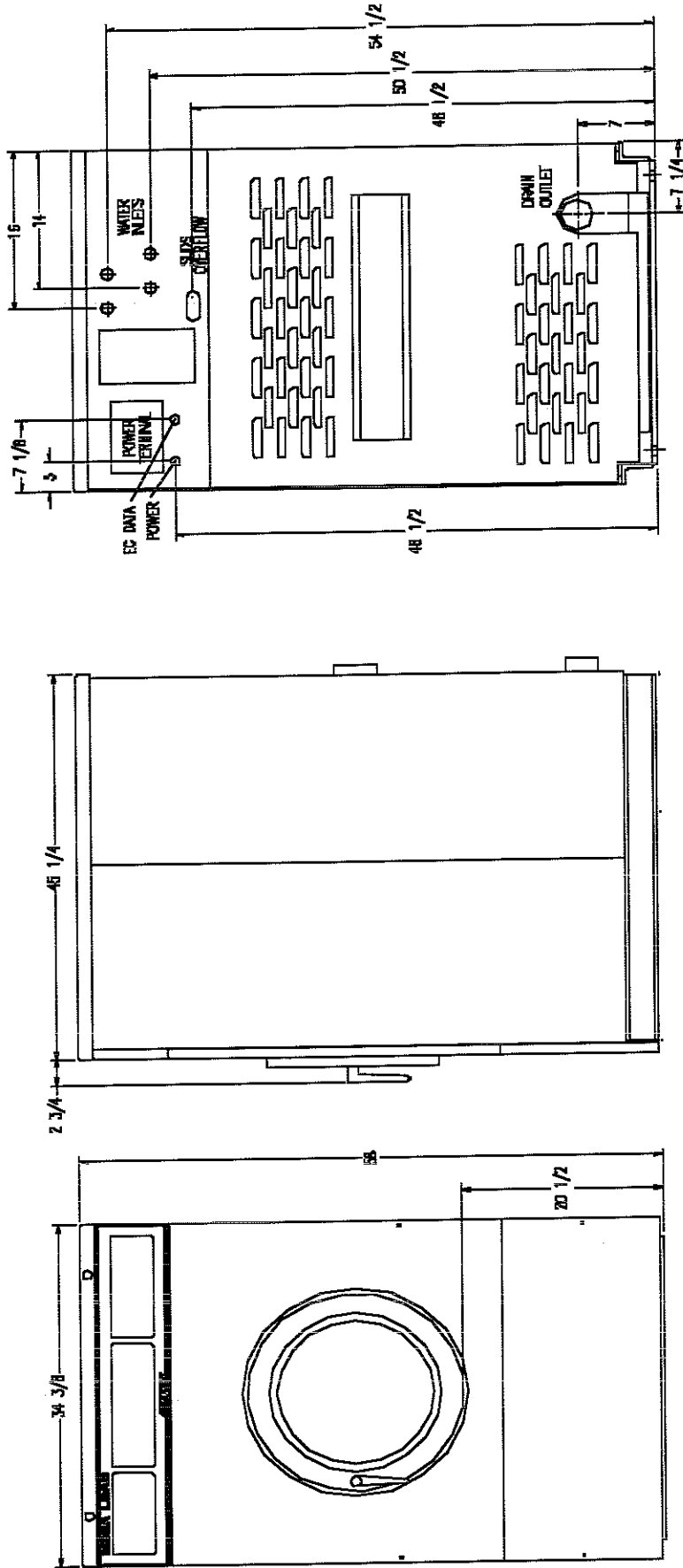

**40 lb.**

40 lb.

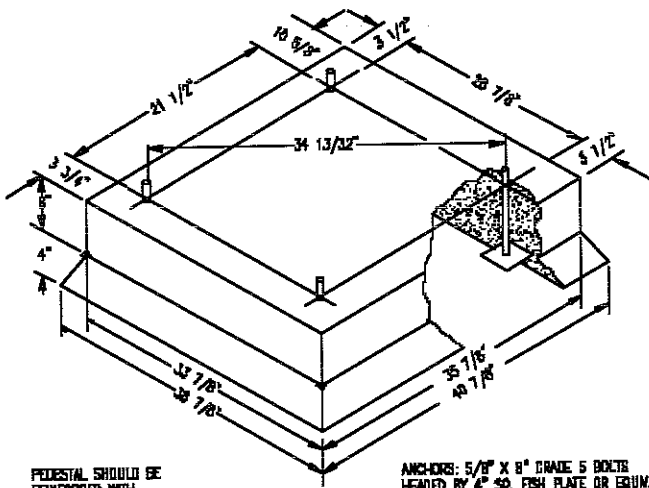

PEDESTAL SHOULD BE REINFORCED WITH MESH OR RIBS.

ANCHORS: 5/8" X 8" GRADE 5 BOLTS HEADED BY 4" SQ. FISH PLATE OR EQUIV. (1 7/8" BOLT PROTRUSION)

CONCRETE PEDESTAL MOUNTING  
Figure 1-1

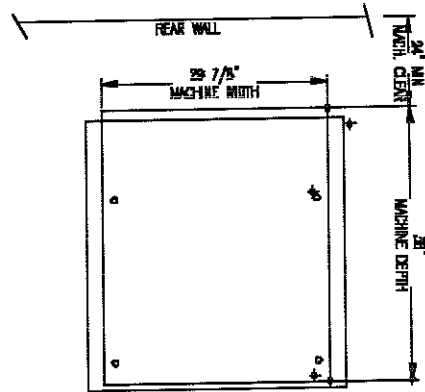
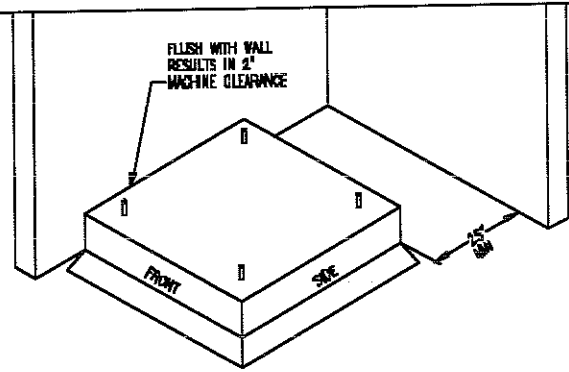

FLOOR OUTLINE  
Figure 1-2

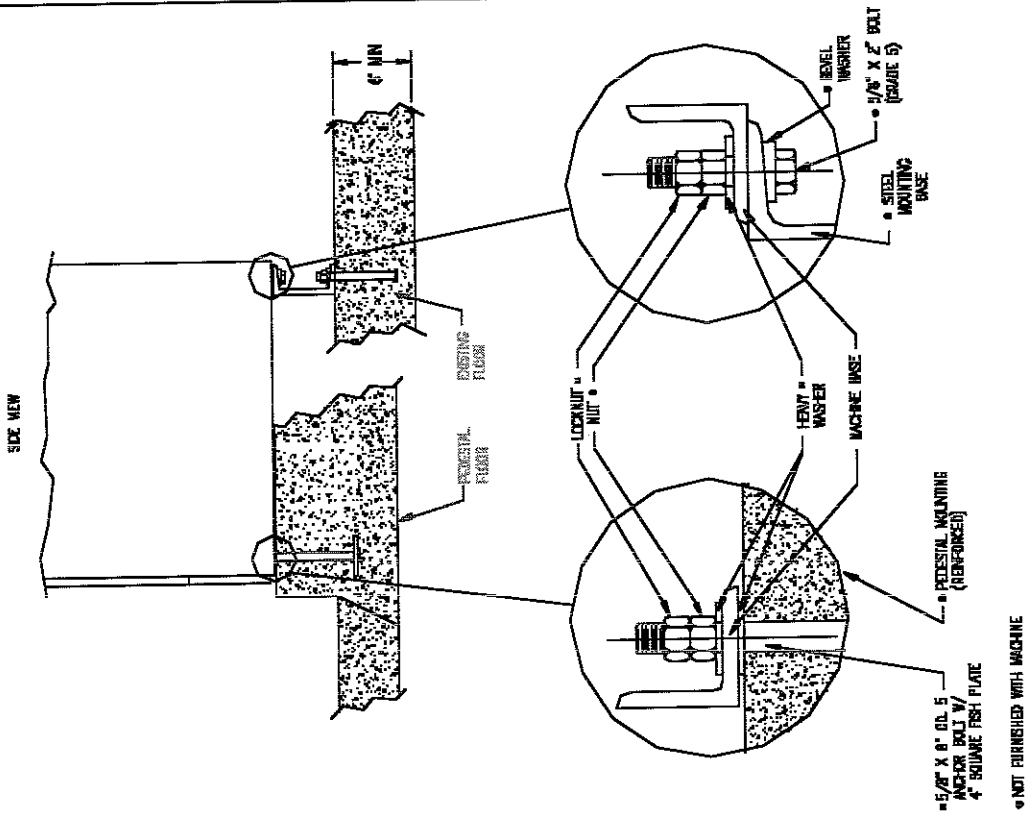

MACHINE MOUNTING DETAIL  
Figure 1-3

75 lb

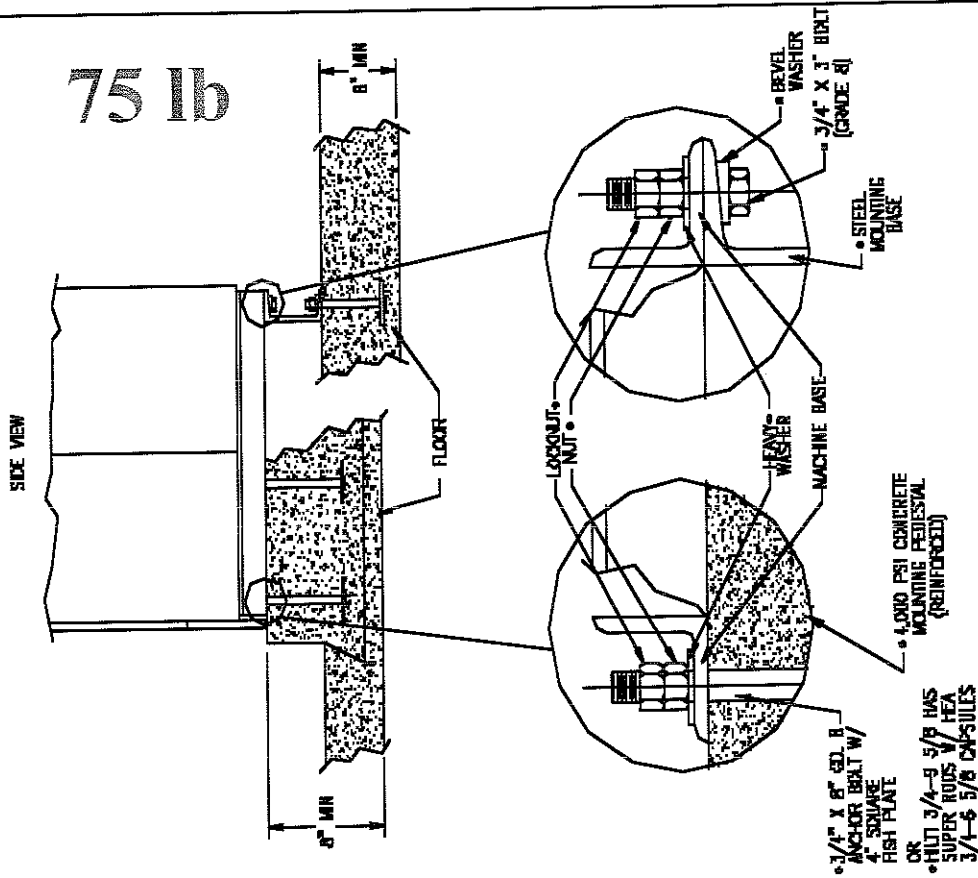

Figure 1

MACHIN

•NOT FURNISHED WITH MACHINE

3/4" X 8" GD. B BOLTS  
HEADED BY 4" SQ. FISH PLATE OR EQUIV.

OR  
'HILTI' ADHESIVE ANCHORING SYSTEM.  
USE HILTI 'HEA' 3/4-8 5/8 ADHESIVE CAPSULES  
AND HILTI 'HAS' SUPER RODS 3/4-9 5/8  
FOR MORE INFORMATION CALL  
HILTI CUSTOMER SERVICE  
1-800-879-8000

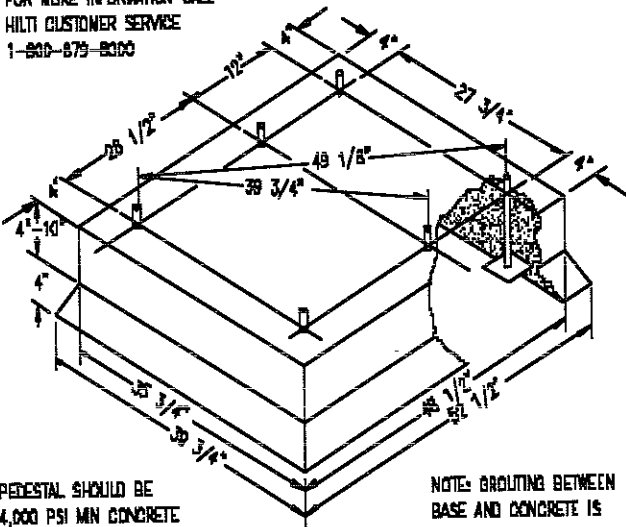

PEDESTAL SHOULD BE  
4,000 PSI MIN CONCRETE  
REINFORCED WITH  
MESH OR RODS.

NOTE: GROUTING BETWEEN  
BASE AND CONCRETE IS  
REQUIRED.

CONCRETE PEDESTAL MOUNTING

Figure 1-1

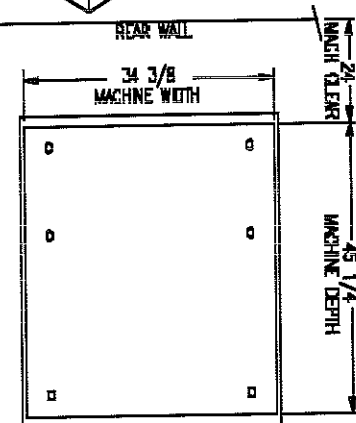
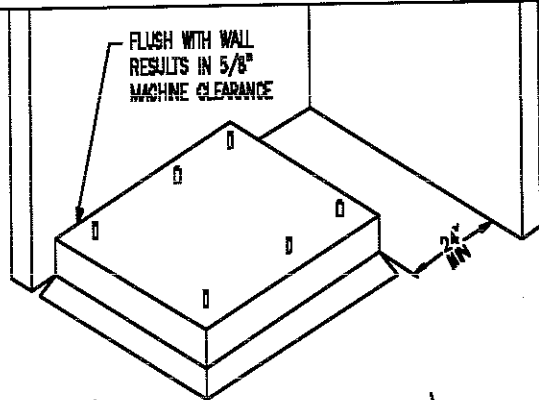

FLOOR OUTLINE

Figure 1-2



**TEMPERATURE SELECTION SWITCH OPERATION AT FACTORY  
DEFAULT SETTINGS**

	Heavy Duty	Normal	Perm Press	Delicates
Prewash	Hot	Warm	Warm	Cold
Wash	Hot	Warm	Warm	Cold
Rinse 1	Cold	Cold	Cold	Cold
Rinse 2	Cold	Cold	Cold	Cold
Rinse 3	Cold	Cold	Cold	Cold

**WASHER WATER USAGE CHART**

GALS. USED FOR 1 WASH & 2 RINSES(factory default program)		18 LB.	25 LB.	40 LB.	55 LB.	75 LB.
PREWASH	NOT USED					
WASH		11	15	21	31	40
RINSE #1	NOT USED					
RINSE #2		6	10	12	15	19
INT. SPIN						
RINSE #3		9	13	18	23	29
TOTALS		26	38	51	69	88

# **Mounting Holes :**

**The preceding pages illustrate the mounting dimensions for the machine and also show a typical base construction.**

**Note: Mounting bolts should be checked frequently to insure that they remain tight.**

**The machine should be checked with a spinning load to be sure there is no unusual vibration or movement between the machine and the base or floor.**

**Photo of Dry Expansion Grout Mix with water to a consistency that is easy to work with.**

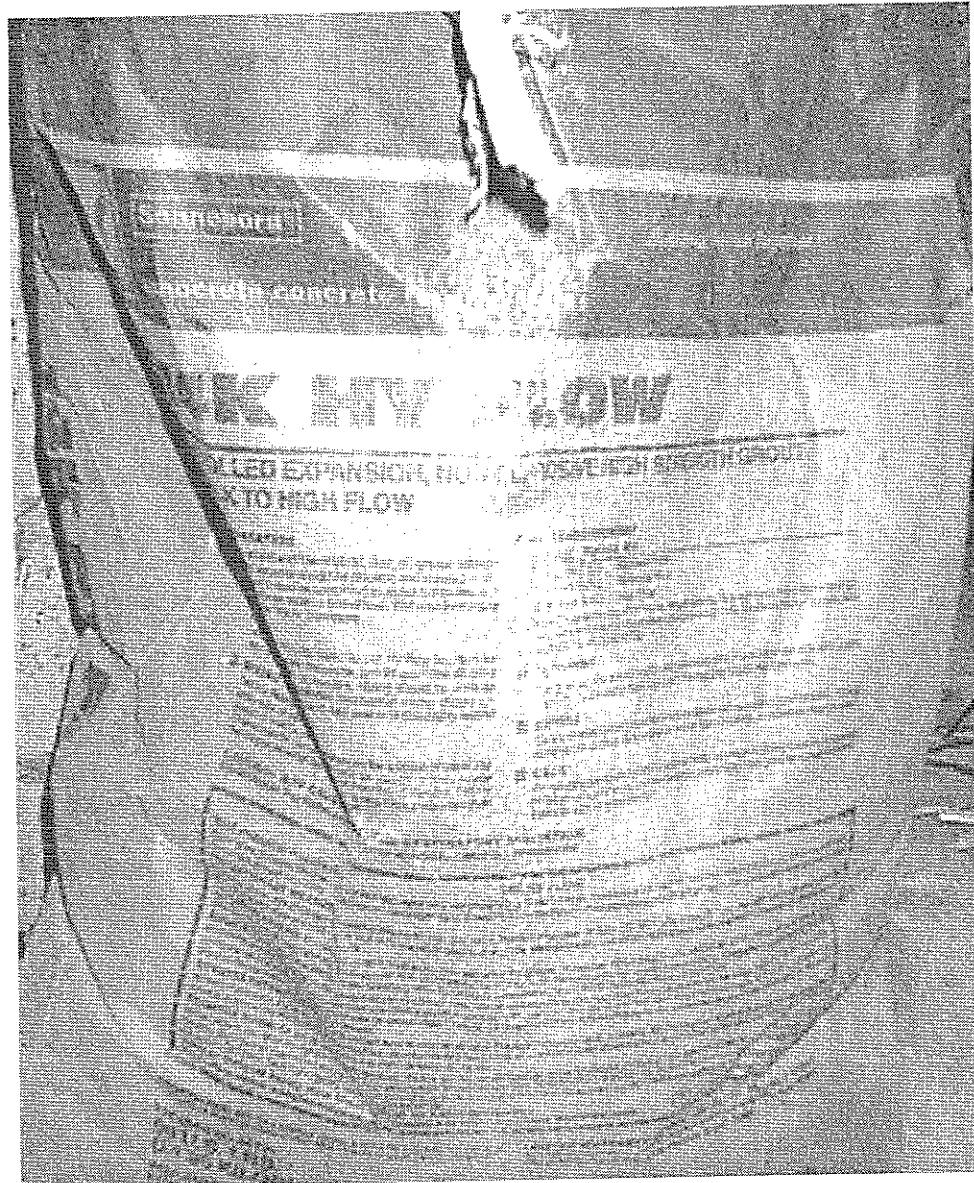

## Electrical

Dexter single/three-phase 208-240VAC 60 Hz washing machines are intended to be permanently installed appliances. No power cord is provided except 18 lb. (see below). The machine should be connected to an individual branch circuit not shared by lighting or other equipment. The connection should be sheathed in liquid tight flexible conduit, or equivalent, with conductors of the proper size and insulation. A qualified technician should make such connections in accordance with the wiring diagram.

Dexter 18lb. WCVD18KCS-10 model (1 phase 120 volts) washers are equipped with an electrical cord with a 3 prong grounded plug. A U.L. approved receptacle, which has been properly grounded in accordance with local electrical codes must be used with the machine. Each unit should be connected to an individual branch circuit not shared by lighting or other equipment. Conductors of the proper size and insulation (suggested size below) should be used.

**TO MAKE ELECTRICAL CONNECTIONS:** Disconnect all power to the washer. Remove screw and lift out the cover located in the upper left corner of the machine (as viewed from the back).

- Ø If power is 208-240-3PH-60Hz, connect L1, L2, L3 and ground. If there is a high leg it must be connected to L3.
- Ø If power is 208-240-1PH-60Hz, connect L1, L2 and Ground.
- Ø If power is 120 -1PH-60Hz. Use a UL approved receptacle with proper external ground.

**NOTE:** It is important that the grounding screw next to the power terminal block TB-1 be connected to a good external ground.

**CONTROLS TRANSFORMER:** The controls transformer is located inside the control trough and steps a range of 208 to 240 volts down to 115 volts. There are two terminals on the controls transformer for the primary (incoming) power. Use the terminal marked "208V" for power supplies between 200 and 216 volts. Use the terminal marked "230V" for power supplies between 217 and 240 volts.

**NOTE: TRANSFORMER MUST BE SET AT PROPER TAP FOR PROPER OPERATION.**

Electrical power connections are made to the small terminal block located in the rear of the control trough. The terminal block is accessed by opening the top panel of the machine.

### 1 Phase and 3 Phase connections

208-240 volts, 60 Hz.

3 wire plus ground

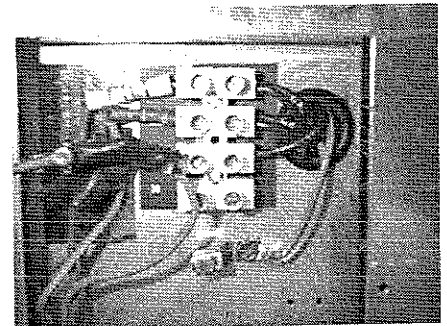

**Suggested Minimum Wire Size -- 12 Ga.**

**Fusing Requirements:** Dual element time delay fuse or equivalent breaker of amperage specified below.

1 Phase or 3 Phase	15 amp	WCVD-18-12, WCVD-25, WCVD-40
1 Phase or 3 Phase	20 amp	WCVD-55, WCVD-75
1 Phase	20 amp	WCVD-18-10 120 volt

**Always disconnect electrical power to the machine before performing any adjustments or service work.**

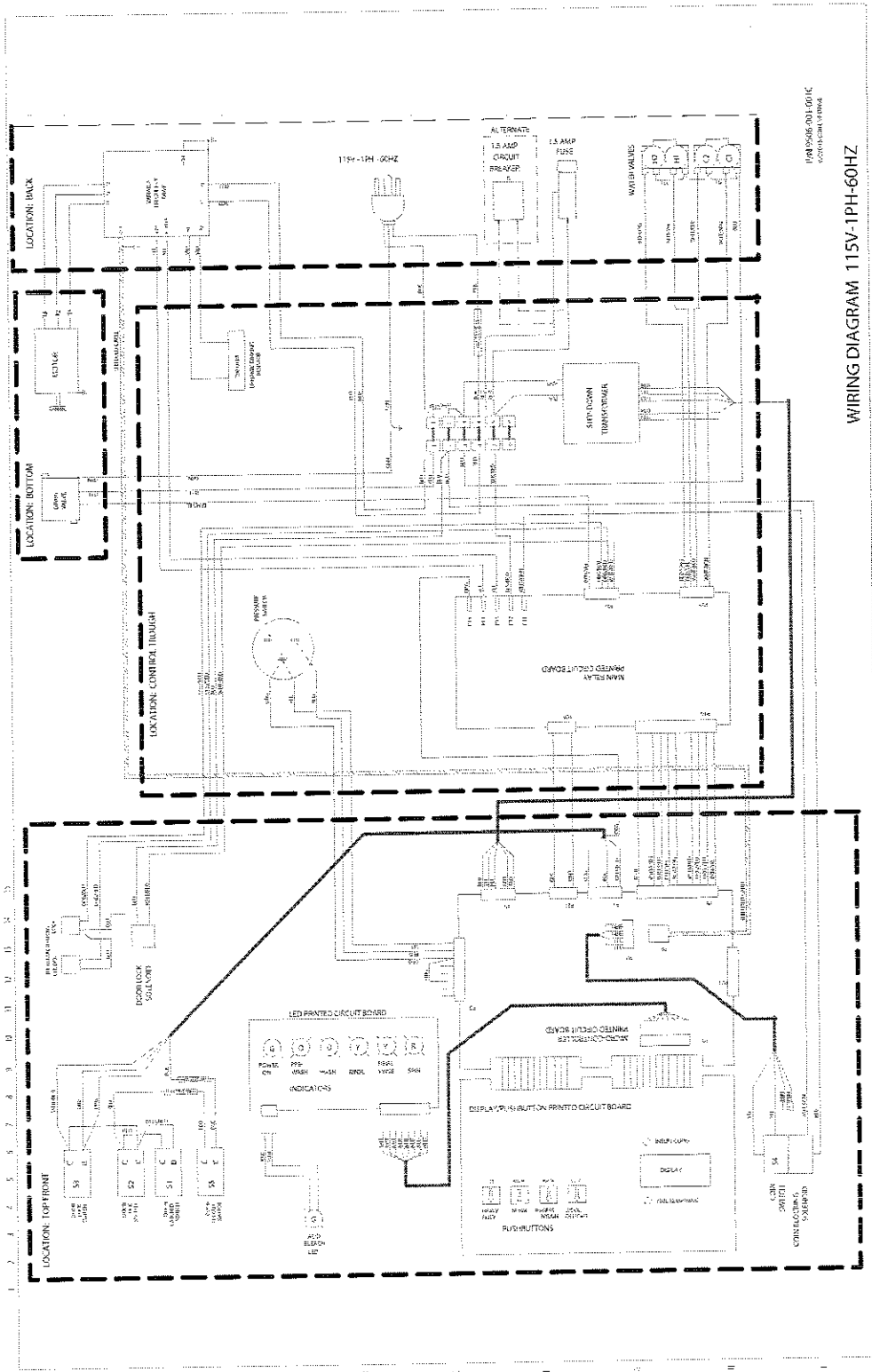

WIRING DIAGRAM 115V-1PH-60HZ

115V-1PH-60HZ  
CONTROL SYSTEM



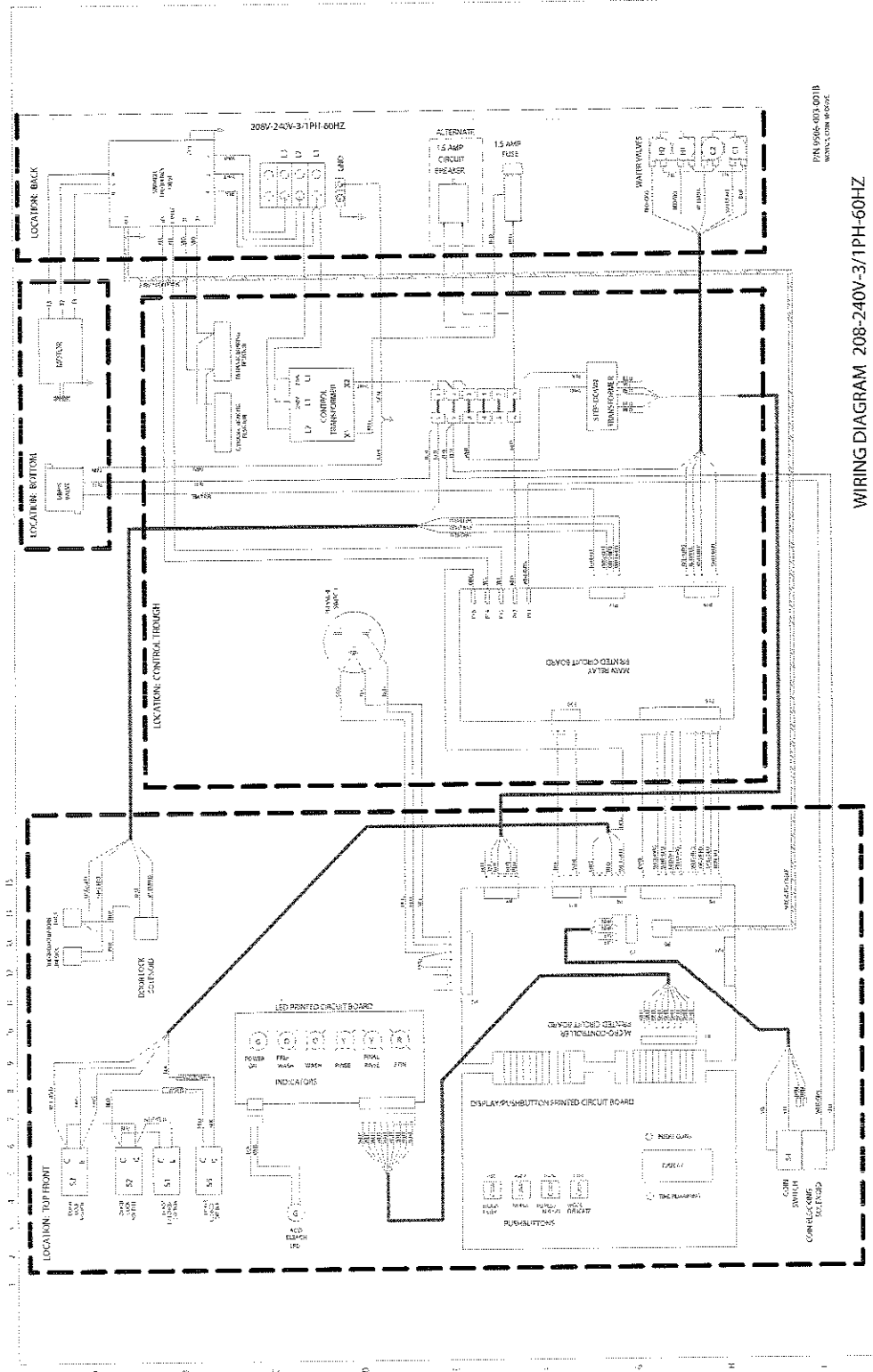

PIN 0065-001.001B  
 WWW.SIEMENS.COM

WIRING DIAGRAM 208-240V-3/1PH-60HZ

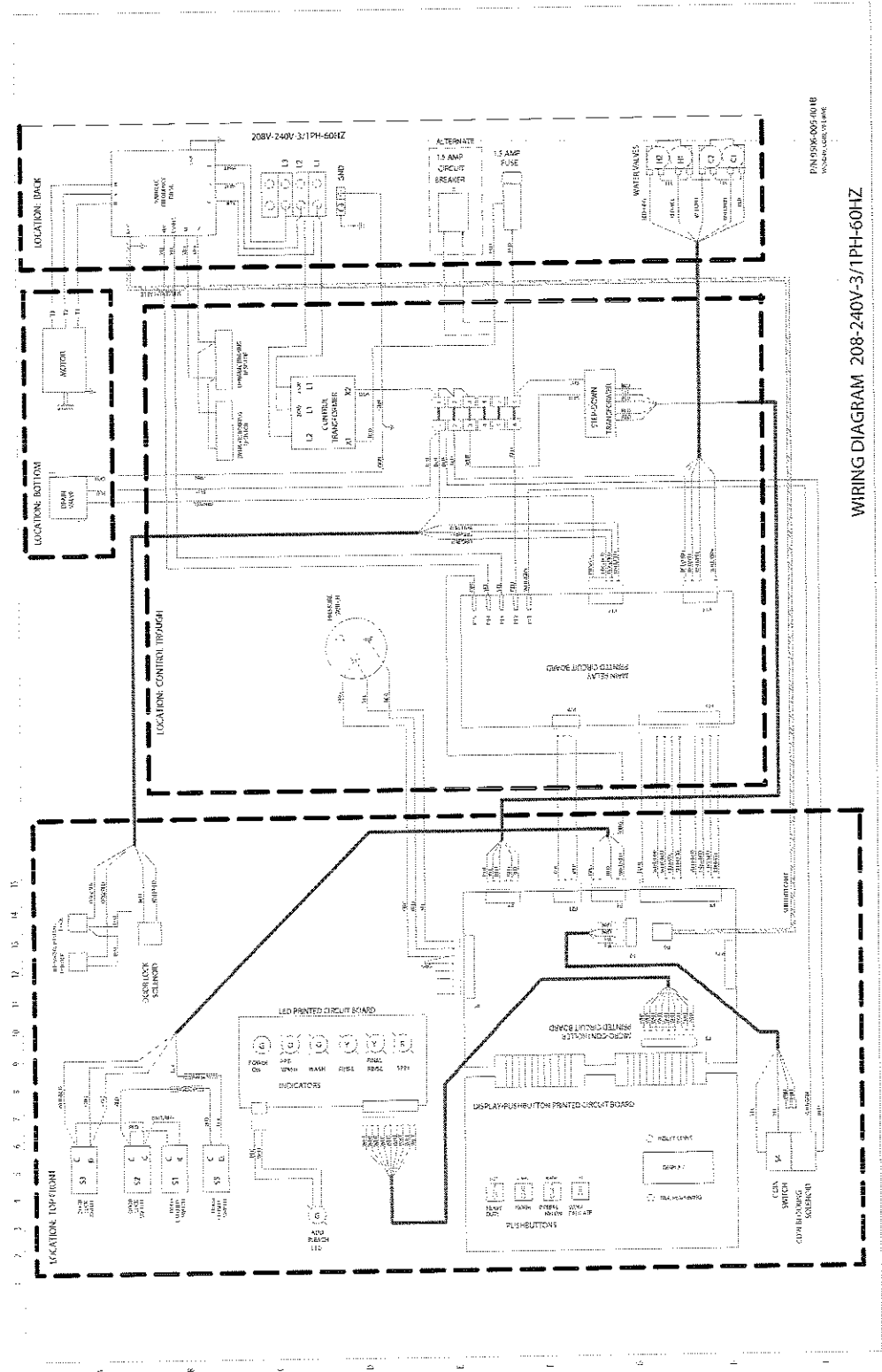

WIRING DIAGRAM 208-240V-3/1PH-60HZ





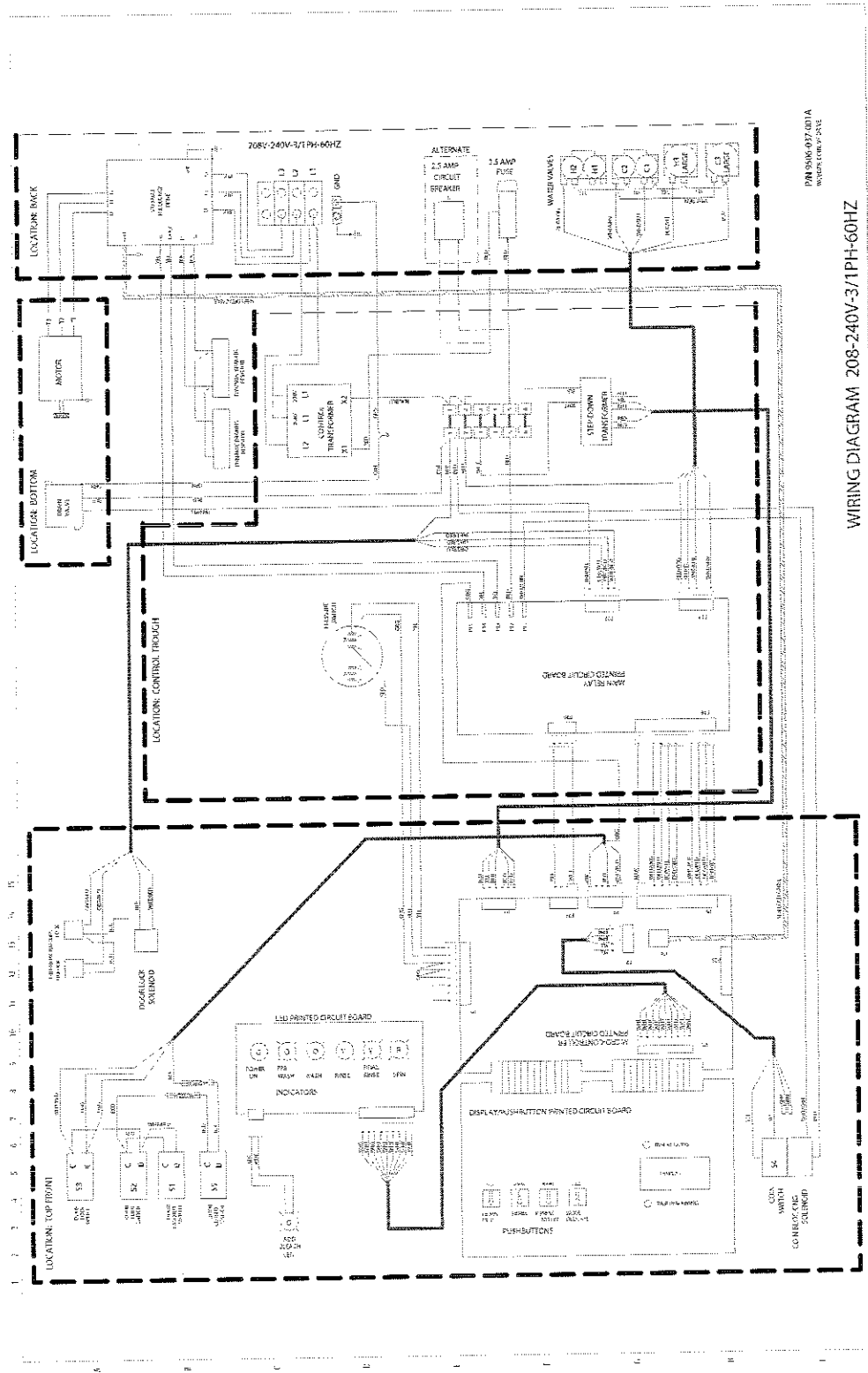

PIN 506-037-001A  
WATER CODE: 7-2010

WIRING DIAGRAM 208-240V-3/1PH-60HZ

## **WATER TEMPERATURE PRICING**

The washer can be set for different levels of pricing for Cold, Warm and Hot water. The Cold water setting is considered as the base price, which is the normal washer cycle price.

**Warm Water Price** – The next step in the pricing program is to set the additional price for Warm water usage. The display will blink first “CH P” indicating cold/hot water mix price and then “00.00”. To change the value, use the Hot temperature button to decrease and the left-hand Warm temperature button to increase. The value will change in 5¢ steps. The range of values is from \$00.00 to \$99.95.

Note: To not use this feature, set the price to “00.00”.

When the desired price is displayed, push the right-hand Warm temperature button once to store the new value and a second time to move to the next Coin/Price programming step. To exit the Coin/Price programming mode, push the Cold temperature button for 5 seconds.

**Hot Water Price** – The next step in the pricing program is to set the additional price for Hot water usage. The display will blink first “H P” indicating hot water price and then “00.00”. To change the value, use the Hot temperature button to decrease and the left-hand Warm temperature button to increase. The value will change in 5¢ steps. The range of values is from \$00.00 to \$99.95.  
Note: To not use this feature, set the price to “00.00”.

When the desired price is displayed, push the right-hand Warm temperature button once to store the new value and a second time to move to the next Coin/Price programming step. To exit the Coin/Price programming mode, push the Cold temperature button for 5 seconds. The Coin/Price programming mode will automatically exit and return to the Idle mode if no buttons are pushed for one minute.

**Plus Cycle Price** — The next step in the programming sequence is the Plus Cycle feature. The Plus Cycle adds three (3) minutes of wash time to the wash bath only. The controller can be programmed to charge a fee for this or the feature can be turned off. The default setting is off. To turn the Plus Cycle feature off, set the Plus Cycle price to zero.

The display will blink first a “PC P” indicating Plus Cycle price and then price (back and forth). To change the value, use the Hot temperature button to decrease and the left-hand Warm temperature button to increase. The value will change in 5¢ steps. The range of values is from \$00.05 to \$99.95. When the desired price is displayed, push the right-hand Warm temperature button once to store the new value and a second time to move to the next Coin/Price programming step. To exit the Coin/Price programming mode, push the Cold temperature button for 5 seconds.

The selected bath LED begins to blink. The display shows the letters "ct" in the left two digits and the bath cycle time in the right two digits. Again the up/down buttons change this value. The range is shown below. If zero time is entered, then the bath will be skipped and the program will return to the bath selection. When the desired cycle time is selected, push enter.

The display shows the letter "t" in the left digit and the letters "CC" appear in the right two digits. This is the bath water temperature. The selection choices are shown below but for the coin washer the value is defaulted to CC. As it is not selectable with a coin washer, the owner pushes enter to continue.

The display shows the letter "L" in the left digit and the letters "LO" appear in the right two digits. This is the bath water level. The selection choices are shown below but for the coin washer the value is defaulted to LO. As it is not selectable with a coin washer, the owner pushes enter to continue.

The display shows the letters "dF" in the left two digits and the letter "t" appears in the right digit. This is the bath delay fill. The selections are "t" for decrementing bath time during the fill or "d" for delay the bath time until water level is reached. When the desired selection is made, push enter.

The display shows the letter "S" in the left digit and the bath spin time in the right two digits. Again the up/down buttons change this value. The range is shown below. When the desired spin time is selected, push enter.

The display shows the letters "IS" in the left two digits and the injection selection appears in the right digit. For the coin washer the default value is "0" and cannot be changed. Push exit.

The display will show "b" and the bath LED lights will stop blinking. Again use the up/down buttons change the bath selection. *To exit the programming mode, push and hold exit until price is displayed.* The cycle will be stored when exiting the programming mode.

### **COIN WASHER CYCLE PARAMETER RANGES**

The range of each cycle parameter is shown below:

Cycle Time "ct" 0 to 15 minutes for Prewash, Rinse1 and Rinse2  
3 to 15 minutes for Wash and Final Rinse  
For the bathes that can, if the time is set to zero, then the bath will be eliminated from the cycle.

Water Temperature "t" HH – hot, CH – warm, CC – cold, EE – no water  
The owner can set the bath default. For the wash bath, the default is over ridden for that cycle by the customer when the temperature is selected.

Water Level "L" LO – low  
The owner can change the displayed value, but for a coinwasher only LO will be put into the cycle.

Delay Fill "dF" The selections are "d" for delay the bath time until water level is reached or "t" for decrement bath time during the fill.

Spin Time "S" 0 to 10 minutes for Prewash, Wash, Rinse1 and Rinse2  
1 to 10 minutes for Final Spin.

"IS" The owner can change the displayed value, but for a coin washer only 0 will be put into the cycle.

# Operating Instructions

## Microprocessor

Prior to operation, the micro computer should be set to display the amount of vend price being offered and the cycle to be given to the user. **NOTE: Should a power loss occur during cycle and when power returns, P U S H will be displayed in window and customer must push a temperature selection button to continue the cycle.**

## Starting the Washer

- A. Load the clothes loosely in the cylinder and latch the door securely. Be sure clothing does not get caught between the door gasket and tub front when closing the door.
- B. Pour low-sudsing powdered detergent in the amount shown below into the detergent dispenser on top of the machine. Rinse conditioners may also be added to the dispenser. The correct location is shown on the dispenser lid.

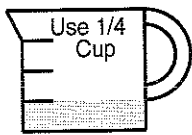

18lb

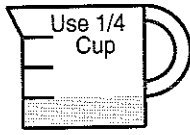

25lb

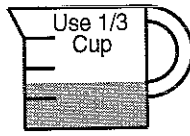

40lb

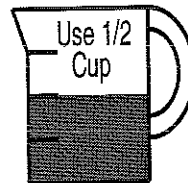

55lb



75lb.

**NOTE: To close the door the handle must be in the horizontal position . After moving the door to the closed position, the handle must be turned down to the vertical position to latch the door for machine operation. This must be accomplished before coins can be inserted.**

- C. Using the TEMPERATURE SELECT buttons on the front, select the desired temperature. If temperature pricing is being used you will display price changes as you push the desired temperature selection. THIS SELECTION MUST BE MADE BEFORE INSERTING COINS TO SATISFY TEMPERATURE PRICE SELECTED.
- D. Insert the appropriate number of coins as shown in the display to start the machine. The washer will automatically start and the green "on" led will glow. The clothes door will lock and remain locked until the end of the cycle.
- E. If utilizing ADD PLUS CYCLE \$.000 option your front display will scroll, ADD PLUS CYCLE .25(example), amount to be added. User will have 1 minute to insert proper amount to activate this option.
- F. At the correct time in the cycle the green "ADD BLEACH" light will come on indicating the time and showing a diagram of the location for adding bleach if desired.

## End of Cycle

When the cycle is completed, the end of cycle beeper will sound and the "on" light will go off. The loading door can now be opened by turning the door handle to the indicated position and pulling. Leave the clothes door open when the machine is not in use. Also, at the end of cycle the display will reset to the original amount required to start.

## Fill Circuit-Warm

S1, S2, S3 and S5 Door Switches are now closed . The green On LED and the Door Lock Solenoid (discussed in Start Circuit) will remain on throughout the cycle. The Lock Thermoactuator receives 115VAC on orange/blue from P17 on main relay PCB and will alternate open and closed keeping the Lock Thermoactuator activated until 1 1/2 minutes before the end of the cycle. At this point the contact opens and removes power to the Lock Thermoactuator. The micro-controlled PCB also sends a signal to the main relay PCB and out through P17. The brown/yellow wire from P17 at main relay PCB supplies 115VAC to Drain valve which closes the valve. The reversing operation which will alternately provide the direction of tumble for the wash basket will be given commands to the VFD through the data cables at P6 micro-controlled PCB. The Prewash or Wash LED will illuminate at this time powered through the white wires from the micro-control PCB P3 to LED printed circuit board.

Now with a temperature cycle previously selected; we'll use Normal Wash as an example; the washer fills the tub through the back of the machine with either one or both the C1 Cold and H1 Hot Water Valves. At the beginning of the wash cycle bath only after a 90 sec. delay, the detergent dispenser flushes the detergent into the tub for 20 sec.. This is accomplished when 120VAC travels through the red/orange wire to the H2 Hot Water Valve Solenoid. As the washer fills with water, the Wash Basket will tumble one direction for 12 seconds, pause, and then reverse direction for 12 seconds. 120VAC goes through the P19 connection of main relay PCB on wht/brn to the C1 cold water valve and the red/yellow wire to the H1 hot water valve if programmed. When the water reaches the predetermined level the Pressure Switch moves switch contacts to the full position and shuts neutral voltage off to the both water valves. Between red wire from P5 micro-controlled PCB on pressure switch contact and yellow and orange wire from P5 micro-controlled PCB at other pressure switch contact a 5 VDC reading will open.

## Wash Circuit

As the washer fills the tub through the back of the machine with either one or both the C1 Cold and H1 Hot Water Valves, the Wash Basket will tumble one direction for 19 seconds, pause 4 seconds, and then reverse direction for 19 seconds. This is accomplished through the use of a variable frequency drive and a reverseing timer. The time of the bath is programmable up 15 minutes per bath used.

## Drain, Rinse 1 & 2, & Final Rinse Circuit

When the bath ends the micro-controller PCB removes 115 VAC power from brn/yel coming from main relay PCB at P17 to the Drain Valve. The normally-open spring-loaded Drain Valve opens and empties the tub. For Rinse 1 & 2, the Rinse LED will illuminate. The rinse water temperatures are programmable and will fill as above.

For the Final Rinse, the Final Rinse LED will illuminate. These water temperatures are programmable also and will fill as described above. Also the softener dispenser will flush cold water from C2 cold water valve solenoid at beginning of final rinse bath for 20 sec..

Fault#	Description	Customer Action
F1	The door failed to close and lock or The door failed to remain locked during the cycle.	Check VFD fault code before turning off .Turn off the power to the washer. Check wire connections to door /lock switches. Check wire connections from switches to controller. Check P-4 wire connections at PCB controller. Adjust the door lock mechanism. (See service manual)
F2	The washer tub does not fill with water within 7 minutes. The wash cycle will continue. The F 2 will flash threetimes, then wait for 30 seconds. The error will clear at the end of the cycle.	Check VFD fault code before turning off power. Turn of the power to the washer. Check the operation of the water valves. Check the incoming water pressure. Check for blocked or restricted water flow. Check to ensure the drain valve is functioning properly. This error will occur on 18# washers when water level is set for high( <u>the pressure switch in 18# washer is only one level</u> ).
F3	Memory error in controller checksum is wrong.	Check VFD fault code before turning off power. The memory Try to clear the fault with the Palm. Try a <u>soft Reset</u> of the controller with the white button. If problem returns then replace controller.
F4	Washer controller communication error	Check VFD fault code before turning off power. Try the data cable first. Move around cable and remove any side loading tension from data cable connector ends.Turn power back on to the washer. If the problem returns,replace the PCB washer controller.
F5	Pressure Switch error (only OPL) - when the high level senor indicates full but the lower one indicates empty. The wash cycle will continue. The F 5 will flash three times, then wait for 30 seconds. The error will clear at the end of the cycle.	Check VFD fault code before turning off power. Check the pressure switch.( <u>Ohm out contacts</u> ). Check pressure switch connections to ensure they are all making good contact. Check the Molex type harness connector to ensure no wire been pushed out of the Molex type housing that it is shorting.

Fault#	Description	Customer Action
I	The drive size setting has changed.	Check VFD fault code before turning off power. Check to ensure all the harnesses are properly connected to the controller. Check to ensure the drive horsepower is proper for this size of washer. If no one has worked on machine very recently then PCB controller or VFD may need to be replaced.
F12	Washer controller internal error	Check VFD fault code before turning off power. Turn off the power to the washer. Wait one to two minute. Turn on the power to the washer. If problem reappears, contact your DEXTER representative.
F13	The control can not communicate with the drive	Check VFD fault code before turning off power. Turn the power off to the washer. Check the data cable between the controller and the drive. Remove any side loading tension on either connector. Replace data cable if no change replace drive next and try again. If still no change replace controller (Check drive fault code before powering down)
F14	Over-current on the drive or motor.	Check VFD fault code before turning off power. Turn the power off to the washer. Check the washer motor to ensure it turns freely. Check for loose wiring connections at the drive and if no change, then check resistance values between motor wires. The drive usually faults first most often this is where standard troubleshooting should start to occur.
F15	Over-voltage on the drive or motor.	(Check drive fault code before powering down) Turn the power off to the washer after checking fault code. Check the washer motor to ensure it turns freely. (Check drive fault code before powering down) Check the wiring connections to the drive, braking resistors and motor. Measure incoming line voltage. Measure braking resistance values. A TVSS should be installed if this fault continues to be displayed for no apparent reason.
F16	Overheating of the drive	Check VFD fault code before turning off power. Turn the power off to the washer. Allow the drive to cool. Check the cooling fins of the drive to ensure proper airflow. Check the wiring to the drive including the fan wiring. If no problem is observed, turn on power to the washer and test.



**Soft Reset** : of the Main front PCB controller is accomplished by pushing the program button located on the rear of the front controller main PCB, and simultaneously turning power on to machine. This reset will bring Main front controller PCB back to factory default settings.

Please record any modified information that has been inserted in memory before attempting to Soft Reset the PCB.

## Fault Warning Codes: F-22 THROUGH F-28

- F-22 Future use
- F-23 VFD has been replaced, disconnected, or removed.
- F-24 Injection relay PCB has been removed or loose connection sensed.
- F-25 Optional water valve PCB or water valve change has occurred .
- F-26 VFD unit has been added or loose connection.
- F-27 Injection relay PCB has been added to machine or loose connection.
- F-28 Optional water valve PCB has been added or loose connection

**Warning codes:** indicate that a component (VFD, relay PCB ,injectionrelay PCB, water valve)has been replaced,added,or removed and you wil I need to soft reset the PCB controller board.

**Note:** Should a power loss occur during cycle and then power returns, **P U S H** will be displayed and customer must push a temperature selection button to continue the cycle.

**Note:** Whenever power is turned off to the washer, it must remain off for up to three minutes.

This will allow most fault codes to reset that are displayed at washer front.

A fault code F-13 or F-21 will appear on front display if this procedure has not been reset correctly.

WASHER CONTROLLER FAULT      VARIABLE FREQUENCY DRIVE FAULT

WHAT'S GOING ON?

CORRECTIVE ACTION

F13	CE10	The variable frequency drive (VFD) and the washer computer are not communicating.	Check the white communication cable between the washer computer and the variable frequency drive (VFD). 1) Make sure the cable did not become unplugged during operation. 2) Make sure that the cable is not being pulled sideways at either the washer controller, or the VFD, plug end. If both ends of the communications cable are plugged in the washer computer and VFD and there is no tension on the communications cable pulling it from side to side, then replace the cable.
F14	oc, ocA, ocd, or ocn	The motor is trying to draw too much current. This can happen during normal operation (oc or ocn), during acceleration (ocA), or during deceleration - slow down (ocd).	1) Check to make sure the washer cylinder turns freely by hand. If it turns freely, continue to step 2. If it does not, remove the belt and see if the motor turns freely by hand. If the motor turns freely, then check for obstructions in the cylinder or check the bearings. If the motor does not turn freely, replace the motor. 2) Check the motor wires for a short circuit between the leads. If there are motor leads that have conductors touching, separate them and insulate them. If the wires are broken, splice them together or replace the motor. 3) Check braking resistors to see if they measure the correct resistance. If a resistor does not measure the proper value, replace it.
F15	ou	The variable frequency drive (VFD) senses that the internal voltage is too high. The source of the problem can originate from two different areas. 1) The input voltage can be too high, or there may be a high level of electrical noise. 2) The motor can be generating a voltage that is acting like an input to the VFD output motor terminals.	1) Measure the supply voltage to the VFD on the L1, L2(or N), and L3(if connected to three phase power). The supply voltage should be from 187 to 264 VAC or 108 to 132 VAC for a 120 VAC VFD. Also make sure the supply wires on L1, L2(or N) and L3(if connected to three phase power) are securely connected. 2) Check the braking resistor connections at the VFD. The terminal screws should be tight. One of the braking resistor wires should be connected to terminal B1 and the other to terminal B2. 3) Measure each braking resistor separately to make sure they are the correct resistance (200Ω for 1 and 2 Hp VFD and 160Ω for 3 Hp VFD). 4) If you have a 240 VAC, high leg voltage supply, try disconnecting the high leg. If this cures the problem, either leave the high leg disconnected, connect a transient voltage surge suppressor (with some form of filtering) at the voltage supply panel, connect a line choke on the high leg, or install a VFD filter

## **DELTA Variable Frequency Drive POWER:**

Mains power is connected to terminals L1, L2, and L3 on the Delta drive. If the washer is connected to a three phase source, there should be voltage present on all three terminals. If the washer is connected to single phase power, there should be voltage present on terminals L1 and L2.

The voltage should measure 208 Volts to 240 Volts A.C. between phases and connected to if connected between three phase). There is a tolerance of  $\pm 10\%$  on the mains voltage (187 Volts to 264 Volts).

## **DELTA VFD MOTOR LEADS:**

The wires from the motor are connected to terminals T1, T2, and T3.

Since this drive uses pulse width modulation, an accurate current or voltage reading is not possible. Although an accurate current reading is not possible, a balanced current reading should be present while the motor is running.

## **DELTA VFD DYNAMIC BRAKING RESISTORS:**

Two, 160 Ohm or 200 Ohm braking resistors (Please check your washer model parts requirements), are connected in parallel and attached to the drive at terminals B1 and B2. These resistors allow the voltage, which is generated by the motor when decelerating, to be dissipated. They will become hot while the motor is slowing down, so care should be taken so as not to come in contact with them. This will prevent an electrical shock and/or a physical burn.

## **DELTA VFD COOLING FAN:**

There is a cooling fan attached to the bottom of the Delta drive. This fan will operate when the internal temperature of the drive reaches a predetermined level, the same way the radiator fan in a newer car operates. **THE FAN CAN OPERATE ANYTIME POWER IS APPLIED TO THE DRIVE!** Remove power to the drive if work is required around the fan.

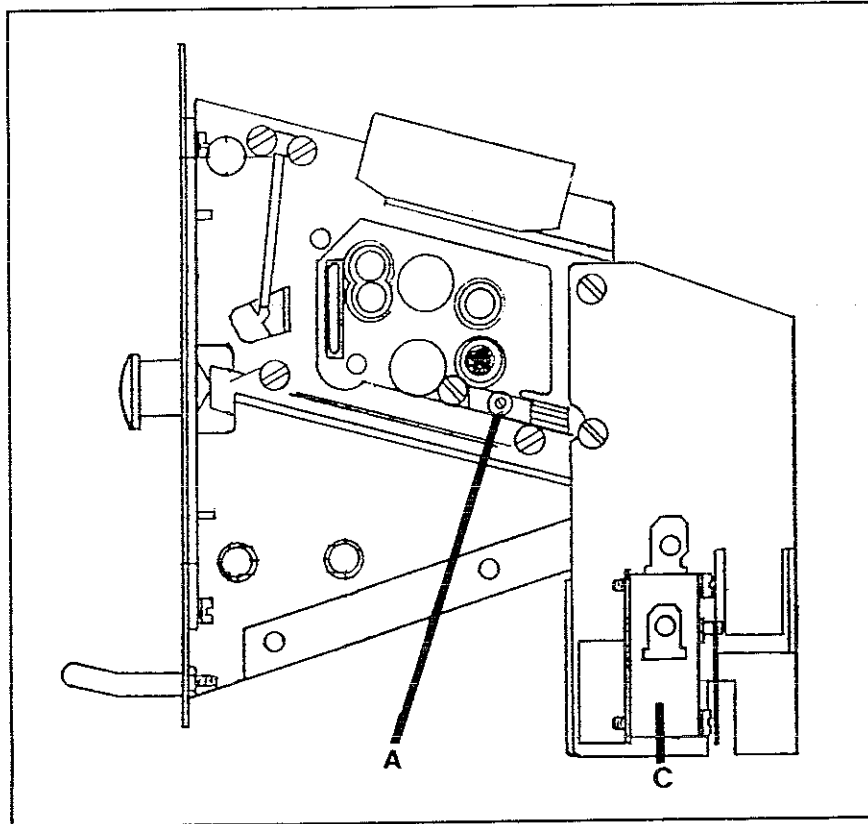

COIN ACCEPTOR - right side

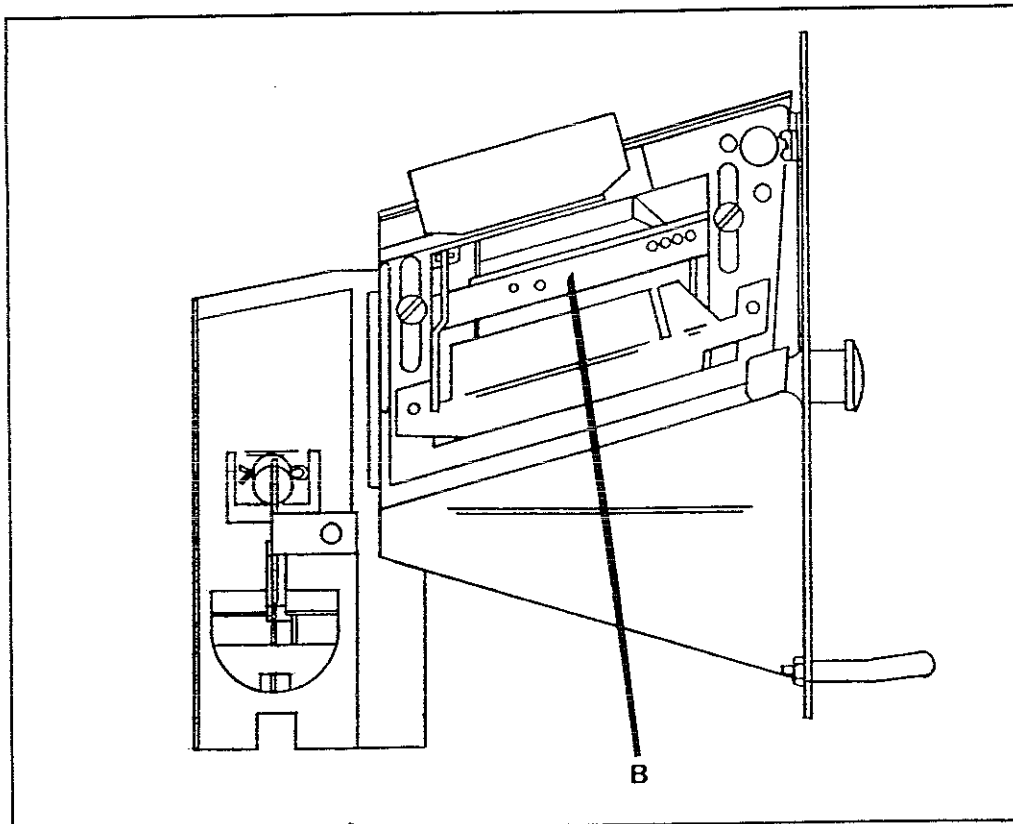

COIN ACCEPTOR - left side

## Masking Ring (door lock cover) Removal

- A. Remove front panel.
- B. Remove nuts that retain masking ring.
- C. Move it to the left and off.

## Door Lock Assembly

After removing the front panel and trim ring, the door lock assembly can now be accessed.

### Operation

After loading the clothing, the door should be closed and latched. The locking cam on the door contacts the latching switch actuator which closes the latching switch. The specified number of coins should now be added to start the washer. This satisfies the coin accumulator which powers the timer rapid advance motor. A timer contact provides power to the latching switch and with the door latched, the power travels through the latching switch to the door lock solenoid. This solenoid pulls up on the locking pawl by use of a linkage rod. The locking pawl has two jobs. The first is to lock the door. This is accomplished by blocking the locking cam on the door so that it can't rotate to unlock. The second job is to close the two piggyback lock sensing switches. These switches control power to all of the controls. If the door unlocks for any reason, these two switches will stop the machine. When the door handle is 1/4 to 1/2 of an inch from its fully closed position, the latching switch should close. The two piggyback lock sensing switches should be open when the door is unlocked and should be closed when the door is locked.

### Adjustment

The latching switch and the piggyback lock sensing switches all have slotted mounting for easy adjustment.

1. Set door cam over pin.
  2. Tighten spring screw on switch actuator arm until it just clears cam OD. ( Note : Spring screw will have approx. 1/8" thread exposed at end beyond nut.)
  3. Set .040 thickness gage between arm and latch switch operator.
  4. Swivel switch until it clicks closed. Back it up just until it clicks for a reset. Tighten in that position.
- Check again for close and rest with gage in place. Remove gage.
5. Check for switch actuation at partial turn of cam as in operation above.
  6. Check that lock arm swings by cam lobe to lock position when switch just clicks.

The next two pages have photos and text to aid in adjustment procedures.

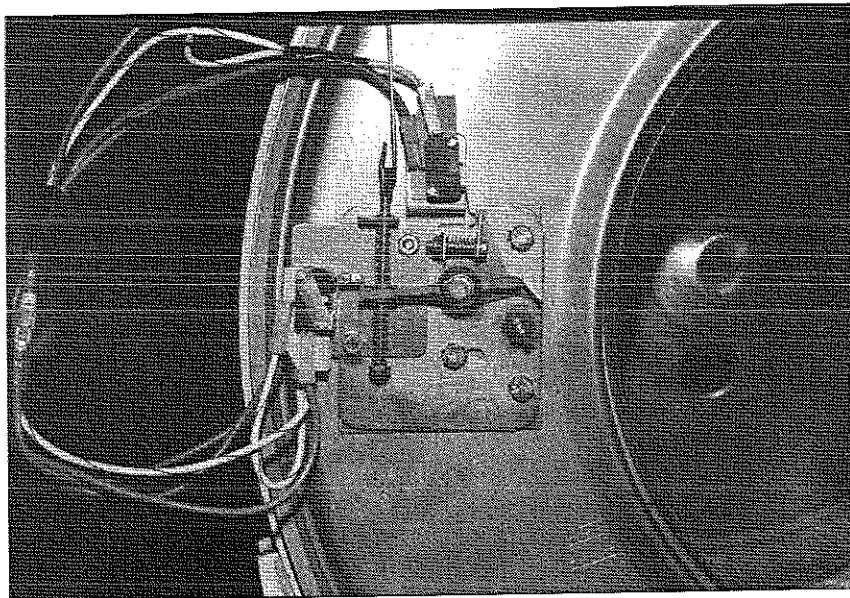

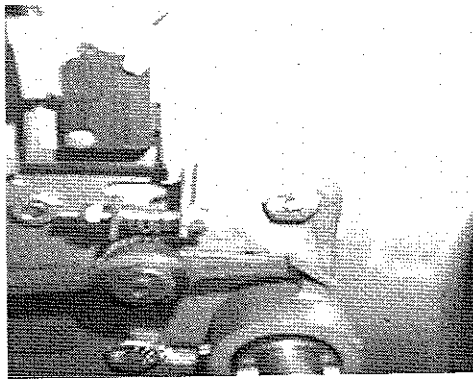

**PHOTO # 5  
SHOWS AREA WHERE CONTACT  
SHOULD BE MADE.**

**PHOTO # 6  
SHOWS LOCK ARM ENGAGED**

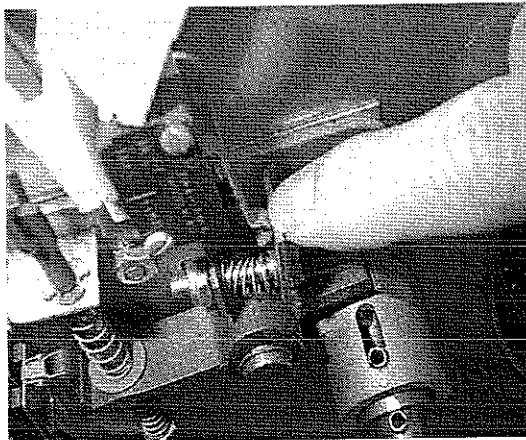
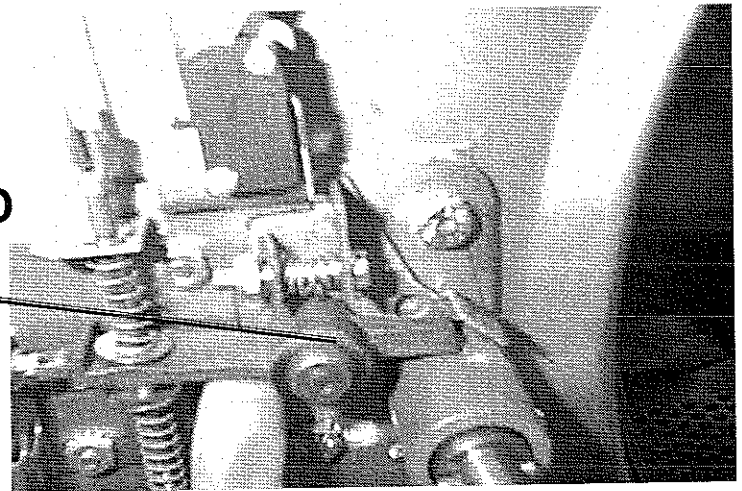

**PHOTO #7  
JUST TO SHOW WITHOUT  
GUAGE IN PLACE.**

**Photo #8**

**GAP REQUIRED AT PIGGY-  
BACK SWITCH ACTUATOR  
(NOT TOUCHING SWITCH  
BUT NO MORE THAN .035  
MAX.**

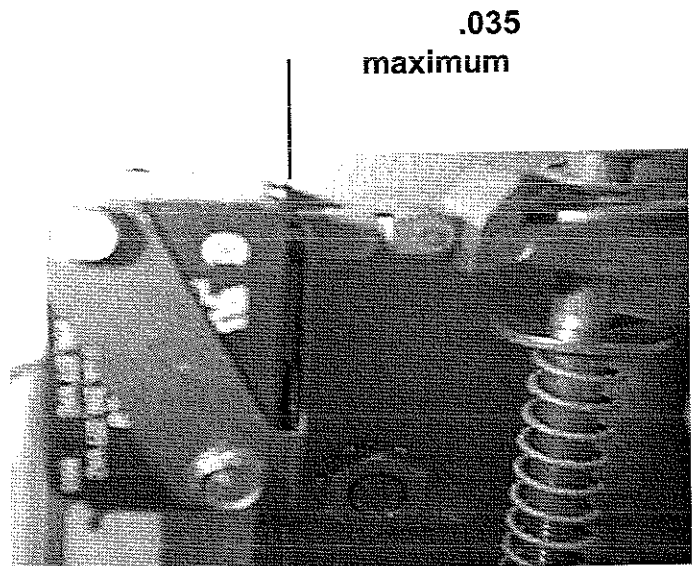

## Back Panel Removal

- A. Remove all screws holding back panel in position except the bottom row.
- B. The bottom row of screws are slotted and only need to be loosened and the panel will lift off.

**Note: The back panel is not only a safety requirement but also contributes to the rigidity of the cabinet.**

## Drive Belt Removal

Turn the drive belt(s) off the basket pulley first and then remove from the motor pulley.  
Reverse this procedure for installation.

**Note: Drive belts that should be replaced in pairs on models that require two belts.**

## Drive Motor

Refer to Specifications Chart for horse power and amperage draw on motors.

### Removal

- A. Remove the drive belt as explained above.
- B. Remove the tension spring and bracket.
- C. Disconnect the motor wires in the control area at the top of the machine. The motor wire retaining clamp should be removed and reused. There is a diagram showing where each motor wire plugs in so there is no need to mark them.
- D. Loosen the set screws on the motor support shaft.
- E. Remove the retaining bolt from the front of the support shaft.
- F. Remove the motor support shaft.
- G. Lift motor out of machine.

**Note: On larger washers it is advisable to put a board under the motor and slide it out rather than lifting it.**

## Control Panel Name Plate

The name plate on washer front is adhesive backed.

### Removal

- A. The name plate may be removed by simply peeling it off.

### Installation

- A. First remove the coin acceptor.
- B. Remove any remaining glue from the control panel.
- C. Before removing the paper backing from the name plate, check fit to the control panel. The program push buttons and the coin acceptor opening are the locating guides.
- D. Remove the paper backing from the right side of the name plate, position it on the panel and press right end into place, then peel the backing from the left end and press into place.

## 55 & 75 LB. Water Seals

### Replacement

- A. Remove cylinder from washer (see Cylinder (basket) removal).
- B. Remove water seals from the seal mounting plate on the cylinder shaft. These are removed with your fingers.
- C. The primary and secondary seals that mount on the sealing ring may be slid over the shaft and seated on the metal sealing ring with your fingers. In the unlikely event that the metal ring that mounts these sealing rings were to be damaged or moved, a new one would need to be pressed on. The T-900 ring must be pushed against the stop on the shaft.

**After installing the seals, lubricate the faces of the seals with silicone grease.**

- D. Install cylinder (see Cylinder (basket) reassembly).

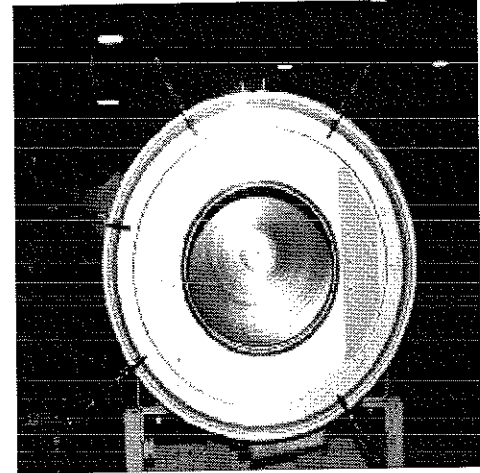

### Bearing Housing Assembly 55 & 75 LB.

#### Removal

- A. Remove cylinder from washer (see Cylinder (basket) removal).
- B. Remove 6 7/16" tub back to bearing housing cap screws.
- C. Remove 6 3/4" bearing housing to frame bolts.
- D. Remove bearing housing from frame.
- E. Remove the retaining ring next to the front bearing.
- F. The bearings are pressed into the housing and must be pressed back out.

#### Reassembly

- A. When installing new bearings into a bearing housing, first press the front (large) bearing into the housing until it bottoms and install the snap ring. With the bearing spacer in place, press the rear bearing in until the spacer is snug between the two bearings.

**Note: If the tub-back water-seal mating ring has been moved it must be cleaned and resealed with silicone rubber around all 6 bolt holes and around the outer edge.**

- B. Set bearing housing on frame.
- C. Install and torque 6 tub back to bearing housing cap screws according to the previous chart.
- D. Install and torque 6 bearing housing to frame bolts according to the previous chart.
- E. Install cylinder (see Cylinder (basket) reassembly).

### Outer Tub 55 & 75 LB.

#### Removal

- A. The outer tub can easily be removed when the tub front, cylinder and bearing housing has been removed as outlined previously.
- B. At that point the only attachments to the chassis are the two front strap mounting bolts.

#### Reassembly

- A. See Cylinder (basket) reassembly.

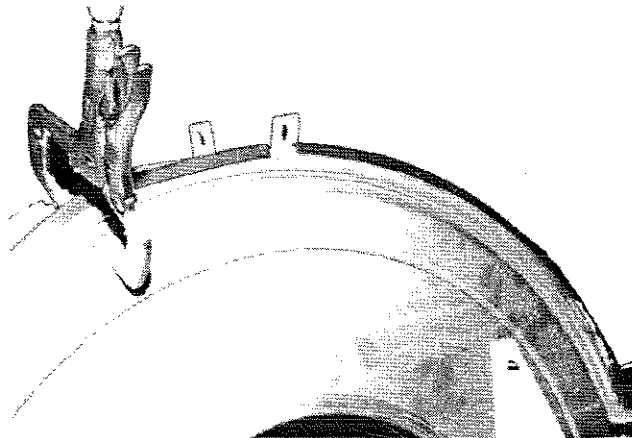



## Tub Back, Bearing and Cylinder (basket) Assembly 18lb.,25lb.,40lb.

### Removal

- A. Remove the top and back panel as described previously.
- B. Move the rear channel, that the water valves mount to, forward by removing the five mounting screws.
- C. Remove the drive belt.
- D. Remove the overflow hose, tub fill hose and pressure switch hose from the back of the tub.
- E. Mark the tub back and bearing assembly for ease in assembly later. (see picture)
- F. Remove the 12 bolts and nuts from the perimeter of the tub back clamp ring. Two of the twelve bolts are longer and go through the thicker part of the brace where it connects to the frame.
- G. Remove the 2 bolts that fasten the clamp ring to the frame.
- H. The entire tub back and cylinder assembly may be lifted out of the tub (it may be necessary to break the adhesion of the silicone that seals the tub back to the tub). Blocks should be placed under the edges of the cylinder before setting it down to prevent damage to the cylinder flange.

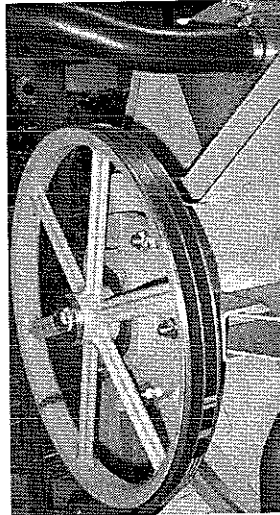

### Reassembly

Reverse the procedures above paying attention to the following areas

- A. Lay the washer on its front.

**Note: Put a thick pad across the front of the washer, above the door, to protect the door handle and coin acceptor.**

- B. Make sure the bearing housing weep holes are located at 12 o'clock and 6 o'clock.
- C. Clean the silicone rubber from the back of the outer tub and the perimeter of the tub back where the two meet. There is no gasket in this area.
- D. Apply a new bead of silicone rubber around the back of the outer tub. (see picture)
- E. Lower the tub back, bearing and cylinder assembly into the washer outer tub. (see picture top of next page)
- F. Torque all bolts according to the following chart.

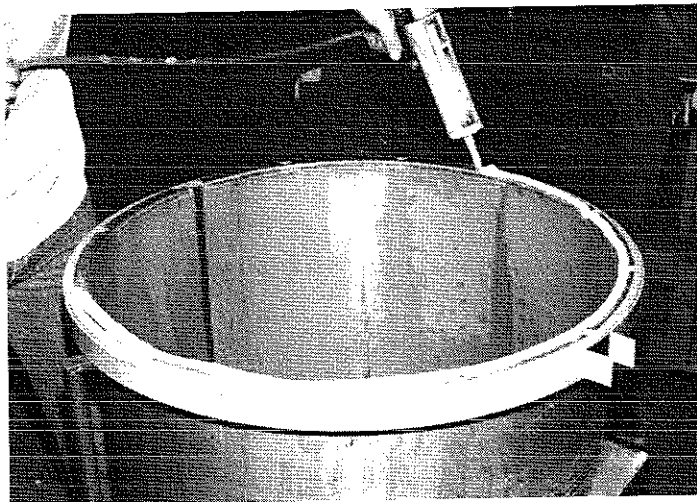

## Bearing Housing, Water Seals and Tub Back 18lb., 25lb.,40lb.

### Removal From Basket Shaft

- A. Remove assembly from washer (see Tub Back, Bearing and Cylinder (basket) Assembly removal).
- B. Remove basket pulley (see Basket Pulley removal above).
- C. It is necessary to use a puller (Grip-O-Matic #1038 for 25lb., #1045 for 40lb. to remove the bearing housing assembly from the cylinder shaft. There is a flange on the bearing housing that should be used with this three armed puller.

### Disassembly

- A. To remove the tub back assembly, the 6 bolts attaching it to the bearing housing must be removed.
- B. Remove water seals from the seal mounting plate on the cylinder shaft. These are removed with your fingers.

**IMPORTANT- Be careful not to move the flat metal plate that mounts the two rubber sealing rings on the cylinder shaft. The location of this seal mounting plate is critical and it must not be moved. The two sealing rings can be replaced without disturbing it. The included illustration shows the proper location of this plate for washer.**

- C. The retaining ring next to the front bearing must also be removed.
- D. The bearings are pressed into the housing and must be pressed back out.

### Reassembly

- A. When installing new bearings into a bearing housing, first press the front (large) bearing into the housing until it bottoms. With the bearing spacer in place, press the rear bearing in until the spacer is snug between the two bearings. Be sure and reinstall the retaining ring in front of the front bearing (see picture).
- B. The tub back assembly should be reattached to the bearing housing with the 6 mounting bolts and torqued according to the torque chart.

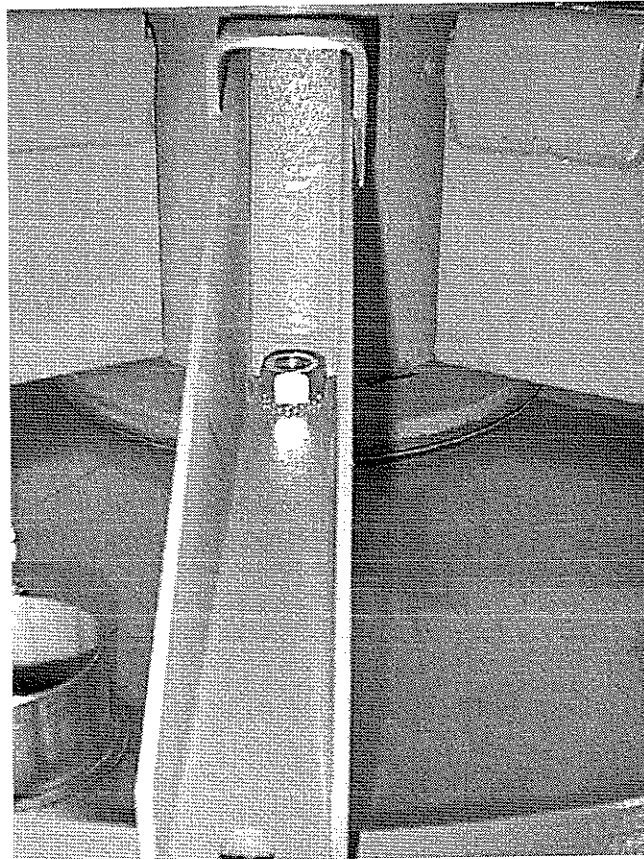

## Outer Tub 18lb.,25lb.,40lb.

### Removal

- A. The outer tub can easily be removed when the tub back, bearing and cylinder assembly have been removed as outlined above.
- B. At that point the only attachments to the chassis are the two front strap mounting bolts.

### Reassembly

- A. Install outer tub in front strap leaving bolts loose.
- B. Install tub back assembly in washer (see reassembly of Tub Back, Bearing and Cylinder (basket) Assembly).
- C. With tub back assembly bolted to washer frame and to the back of the outer tub, tighten front strap bolts.

### Removal of Cabinet 18lb,25lb.,40lb.

- A. The power supply, water hoses, and drain connection must all be disconnected before proceeding with the disassembly.
- B. Now remove the lower service panel and the top panel assembly.
- C. Remove the left and right lower front panel screws that retain the panel to the chassis.
- D. Remove the bottom row of back panel screws.
- E. Remove the loading door.
- F. Remove the screws along the bottom of each side panel. When reinstalling these screws do not overtighten.
- G. Remove clamp and soap dispenser hose where it attaches to the tub inlet.
- H. Disconnect the door lock wires from all switches and the door lock solenoid. The following illustration of their locations should be consulted.
- I. Disconnect pull rod between solenoid and door lock assembly.
- J. Disconnect the wires to the dump valve at the bottom of the machine.
- K. Disconnect the wires to the drive motor. There is a motor harness connector in the left rear corner of the control trough. The connector may be removed from the side of the trough by releasing the retainer ears. The wires from the trough components to the motor harness may be removed from the top side of the connector. There is a label on the trough floor to aid in reconnection of the wires to the connector.
- L. Remove the clamp and the hose from the vacuum breaker where it connects to the inlet on the back of the tub.
- M. Remove the pressure switch hose from the bottom of the switch.
- N. It should now be possible for two people to lift the cabinet up and off of the front of the machine and set it aside.

Symptom	Probable Cause	Suggested Remedy
Machine will not accept and count coins  (continued)	Control Breaker or fuse	Check 1.5 amp( 75lb uses 2.5 amp) breaker or fuse for continuity. If no continuity, replace breaker.
Door does not lock	Check Display for fault code	Does F1 show on the front of display.If yes follow tests described in fault code section.
	Door locking solenoid	Check to insure that solenoid is receiving 120VAC from S1 door switch. If it is, replace solenoid.
	Door Switch	Check for continuity through door latch switch when door closed. If no continuity, adjust or replace door switch.
Door will not open	Thermoactuator	Check to see if thermoactuator(s) and/or its mechanism is stuck or binding and not allowing the door lock solenoid to open. Check to be sure that the locking thermoactuator is not receiving 120VAC during the last 1 1/2 minutes of the cycle. Also check to see that the unlocking thermoactuator is receiving 120VAC during the last minute of the cycle. If the thermoactuators do not receive voltage at the correct times, change the timer. If the timing and voltage are correct, replace the thermoactuator.
	Door Rod	Check to see that door rod from solenoid to lock ass'y is long enough to allow lock ass'y to disengage. If not, adjust rod.
	Door Lock Solenoid	Check that door lock solenoid is not stuck closed. If stuck, replace solenoid.

Symptom	Probable Cause	Suggested Remedy
Water does not flush softener compartment.	Water Valve Coil	Check coil continuity at terminals and replace if no continuity.
	Water Inlet Screens	Check water inlet screens for blockage and clean if necessary.
	Water	Check to insure that water is turned on and operating.
	Pressure Switch	Check pressure switch continuity between terminals. If no continuity, check pressure switch hose for obstruction. If hose okay, change pressure switch.
Water comes in but level does not rise	Drain Valve (open)	Check these areas - Drain valve blockage - Drain valve motor and gear train. If power but drain valve does not close, replace valve. - Power to the drain valve. If no power to drain valve, check (brn/yel) circuit for power.
Water level too high	Pressure Switch	Check for blockage in pressure switch hose. Check for pressure switch opening circuit across terminals . Replace switch if contacts do not open.
Water drains slowly	Drain System	Check hoses and drain valve for blockage. Clean if necessary. Check building drains for blockage or inadequate size.
Machine does not turn	VFD	Check VFD by removing inspection panel and record any numbers or letters displayed. If no display turn power off to machine at breaker for 2 minutes and turn power back on to reset. If still no display replace VFD.

**Symptom****Probable Cause****Suggested Remedy**

Excessive vibration

Mounting System

Check these areas:

- Strength of mounting structure, concrete or base.
- Mounting bolts may be loose and need tightening.

Drive Belt

Worn drive belt can cause vibration and noise.

Loading

NOTE: SMALL LOADS CONTRIBUTE TO OUT OF BALANCE LOADING AND INCREASE VIBRATION.

## CABINET AND FRONT PANEL GROUP .....

Key	Part Number	Description .....	
1	9454-656-001	Panel, Side (Left or Right) - stainless WCVD-25 .....	2
1	9454-672-001	Panel, Side (Left or Right)-stainless WCVD-55 .....	4
1	9454-635-005	Panel, Right Side-stainless WCVD-18 .....	1
1	9454-635-006	Panel, Left Side - stainless WCVD-18 .....	1
1	9989-449-001	Panel, Side (Left or Right)-stainless WCDV-40 .....	2
1	9454-760-001	Panel, Side ( Left or Right)-stainless WCVD-75 .....	4
2	9545-018-013	Screw, (Side Panel to Base) WCVD-25 .....	6
2	9545-018-013	Screw, (Side Panel to Base) WCVD-40 & 55 & 75 .....	8
2	9545-018-018	Screw, (Side Panel to Base) WCVD-18 .....	6
2	8640-414-006	Nut, Hex 1/4-20 UNC WCVD-18 & 25 .....	6
2	8640-414-006	Nut, Hex 1/4-20 UNC WCVD-40 & 55 & 75 .....	8
3	9029-066-001	Bracket, Side Panel WCVD-18 & 25 & 40 .....	1
*	8640-413-002	Nut, Hex WCVD-18 & 25 & 40 .....	2
*	9545-008-031	Screw WCVD-18 & 25 & 40 .....	2
4	9454-659-001	Panel Assy, Front WCVD-25 .....	1
4	9454-671-001	Panel Assy, Front WCVD-55 .....	1
4	9454-763-001	Panel Assy, Front WCVD-75 .....	1
4	9454-728-001	Panel Assy, Front WCVD-18 .....	1
4	9454-669-001	Panel Assy, Front WCVD-40 .....	1
5	9059-063-002	Band, Edge Protector WCVD-25 & 40 & 55 & 75 .....	1
5	9059-063-004	Band, Edge Protector WCVD-18 .....	1
*	9051-053-001	Bumper Loading Door WCVD-75 .....	1
*	9545-008-024	Screw, Hex- To Control Panel .....	2
*	8640-399-005	Nut, Spring- To Control Panel 10/32 .....	2
6	9545-008-014	Screw, Flat Head- Front to Sides .....	2
6	8641-585-001	Washer, Finish .....	2
*	8640-399-008	Nut, Spring- To Front Panel .....	2
*	9545-008-023	Screw, Guide .....	2
7	8502-624-002	Label, Door Opening .....	1
8	9989-474-001	Panel, Control (Mounts Nameplate) WCVD-25, .....	1
8	9989-476-001	Panel, Control (Mounts Nameplate) WCVD-55, WCVD-75 .....	1
8	9989-473-001	Panel, Control (Mounts Nameplate) WCVD-18 .....	1
8	9989-475-001	Panel, Ccontrol (Mounts Nameplate) WCVD-40 .....	1
*	9545-008-026	Screw, Control Panel to Sides .....	4
9	9412-113-001	Nameplate Decal, Control Panel (one piece) WCVD-25 .....	1
9	9412-112-001	Nameplate Decal, Control Panel (one piece) WCVD-18 .....	1
9	9412-114-001	Nameplate Decal, Control Panel (one piece) WCVD-40 .....	1
9	9412-115-001	Nameplate Decal, Control Panel (one piece) WCVD-55 .....	1
9	9412-130-001	Nameplate Decal, Control Panel (one piece) WCVD-75 .....	1
10	9454-761-001	Panel Top Front WCVD-75 .....	1
10	9454-762-001	Panel Top Rear WCVD-75 .....	1
10	9454-736-001	Panel Top WCVD-55 .....	1
10	9454-733-001	Panel Top WCVD-18 .....	1
10	9454-735-001	Panel Top WCVD-40 .....	1
10	9454-734-001	Panel, Top WCVD-25 .....	1
11	8650-012-003	Lock, Top (w/Key) WCVD-18,WCVD-25,WCVD-40 .....	1
11	8650-012-003	Lock, Top (w/key) WCVD-55, WCVD-75 .....	2

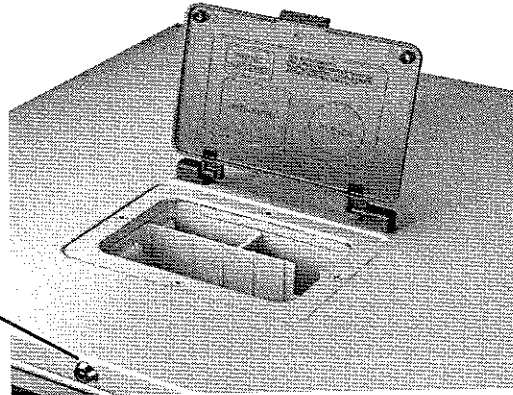

11

11

10

9

4

11

17

5

3 & 4  
mounted here

2

10

9

4



## REAR VIEW WCVD-18,WCVD-25,WCVD-40

Key	Part Number	Description	
1	9376-305-001	Drive Motor, 3 Phase (Inverter duty) WCVD-25,WCVD-40	1
1	9376-304-001	Drive Motor, 3 Phase (Inverter duty) WCVD-18	1
2	9497-222-002	Rod, Motor Mtg WCVD-18,WCVD-25	1
2	9497-222-004	Rod, Motor Mtg WCVD-14	
*	9545-029-005	Screw (end of motor rod) WCVD-18,WCVD-25,WCVD-40	1
*	8641-582-014	Lockwasher (end of motor rod)WCVD-18,WCVD-25,WCVD-40	1
3	9076-052-002	Collar, Shaft (w/set screws)	2
4	9453-170-003	Pulley, Motor WCVD-25,WCVD-40	1
4	9453-169-012	Pulley, Motor WCVD-18	1
*	9545-028-015	Set Screw,Sq.Hd(motor pulley)WCVD-18,WCVD-25,WCVD-40	2
*	9487-234-001	Tolerance Ring WCVD-25	1
*	9487-234-002	Tolerance Ring WCVD-18	1
*	9487-234-003	Tolerance Ring WCVD-40	1
5	9453-168-003	Pulley, Driven WCVD-40	1
5	9453-168-004	Pulley, Driven WCVD-25	1
5	9908-041-002	Pulley,Ass'y Driven WCVD-18	1
6	9545-017-009	Screw 1/2-13x1 1/4" WCVD-18,WCVD-25	1
7	8641-581-026	Washer, Flat 1/2" WCVD-18,WCVD-25	1
6	8641-582-016	Lockwasher 1/2" WCVD-18,WCVD-25	1
6	9545-060-001	Screw 5/8-11x1 1/2" WCVD-40	1
7	8641-581-032	Washer, Flat 5/8x2 1/4" WCVD-40	1
6	8641-582-018	Lockwasher 5/8" WCVD-40	1
8	9040-076-004	Drive Belt WCVD-18	1
8	9040-076-005	Drive Belt WCVD-25,WCVD-40	2
9	9081-135-001	Channel, Rear WCVD-25	1
9	9081-132-001	Channel, Rear WCVD-18	1
9	9081-134-001	Channel, Rear WCVD-40	1
10	9545-008-026	Screw	4
*	8640-399-008	Nut, Spring	4
11	9242-449-002	Hose, Overflow to drain WCVD-25 WCVD-40,WCVD-18	1
*	9242-463-003	Hose, Overflow Vent 12 1/4" WCVD-40	1
*	9242-463-001	Hose, Overflow Vent 9" WCVD-18	1
*	9242-463-002	Hose, Overflow Vent 11" WCVD-25	1
12	8654-117-008	Clamp, Hose Vent	1
12	8654-029-000	Clamp, Hose overflow to drain	2
13	9610-001-001	Vaccum Breaker ALL	1

\* Not Illustrated

# WATER INLET VALVE BREAKDOWN

## WCVD-18, WCVD-25, WCVD-40, WCVD-55

Key	Part Number	Description	Description
*	9379-183-003	Valve, Water Inlet (includes 1 thru 6) .....	2
1	9555-056-001	Screen, Inlet end of valve .....	2
2	9089-017-001	Coil Assy., 120 V .....	2
3	9118-049-001	Diaphragm .....	2
4	9211-021-002	Guide, Solenoid .....	2
5	9015-008-001	Armature .....	2
6	9534-298-001	Spring, Armature .....	2
*	9545-008-026	Screw, Valve Mtg .....	2
<b>WCVD-75</b>			
*	9379-192-001	Valve, Water Inlet double outlet .....	2
*	9379-194-001	Valve, Water Inlet single outlet .....	2

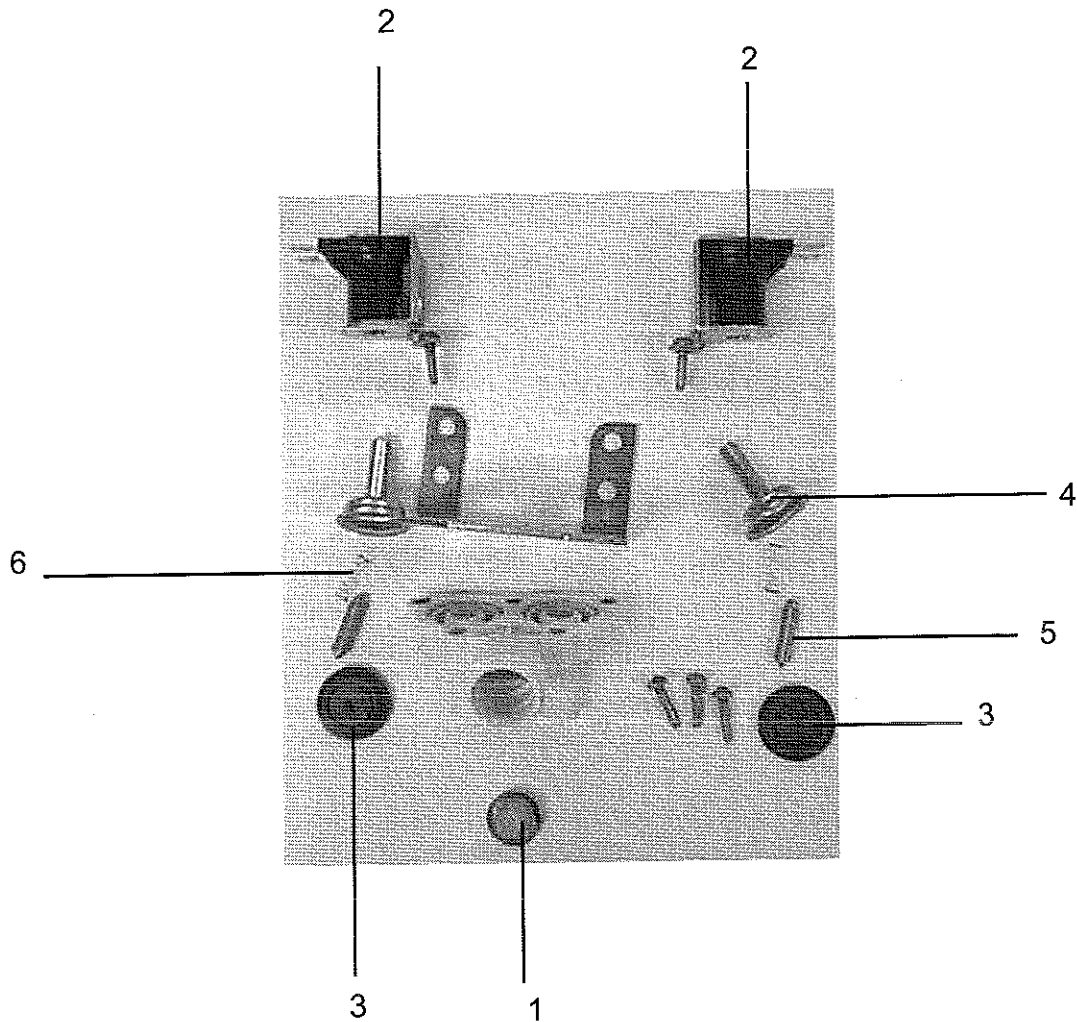

## REAR VIEW 55LB. ,75 LB.

13*	9989-455-001	Panel Assy., Back WCVD-55 .....	1
13*	9989-491-001	Panel Assy, Back WCVD-75 .....	1
14*	9545-008-026	Screw Panel Mtg.#10Bx1/2" WCVD-55 .....	9
14*	9545-008-026	Screw Panel Mtg.#10Bx1/2" WCVD-75 .....	13
15*	8640-399-008	Nut, Spring WCVD-55 .....	6
15*	8640-399-008	Nut, Spring WCVD-75 .....	10
16	9545-030-002	Screw, to Base 1/4Bx3/4" WCVD-55,WCVD-75 .....	3
17	9242-175-003	Hose, Pressure Switch WCVD-55 .....	1
17	9242-175-006	Hose, Pressure Switch WCVD-75 .....	1
18*	8654-117-015	Clamp, Pressure Sw. Hose .....	1
19	5198-211-004	Circuit Breaker, 1.5 amp WCVD-55 optional .....	0
19*	9200-001-002	Fuseholder .....	1
19*	8636-018-001	Fuse 1.5 amp WCVD-55 .....	1
19*	8636-018-004	Fuse 2.5 amp WCVD-75 .....	1
20	9242-458-003	Hose, Vacuum Breaker to tub WCVD-55, WCVD-75 .....	1
21*	8654-117-014	Clamp, Hose to Vacuum Breaker WCVD-75, WCVD-55 .....	1
11	9099-012-003	Chain ( Spring Tension) WCVD-55 .....	1
11	9099-012-004	Chain ( Spring Tension) WCVD-75 .....	1
22	9534-151-000	Spring, Belt Tension .....	1
23	9545-055-001	Bolt, Eye ( 1/4"-20 x 2 1/2") .....	1
24	8640-414-003	Nut, 1/4 Elastic Stop .....	1
25	9375-009-002	VFD Delta "S" drive WCVD-55 .....	1
25	9375-009-005	VFD Delta "S" drive WCVD-75 .....	1
26	9483-004-003	Braking resistors ( 160 ohm ) 55lb.,75lb. ....	2
26	9985-115-001	Bracket ass'y(drive mounting) WCVD-55 .....	1
<b>26</b>	<b>9029-150-001</b>	<b>Bracket ass.y (drive mounting) WCVD-75 .....</b>	<b>1</b>
27	9376-298-001	Drive Motor WCVD-55, WCVD-75 3 phase inverter dot .....	1
12	9497-222-004	Rod, Motor Mtg WCVD-55,WCVD-75 .....	1
12	9545-029-005	Screw (end of motor rod) .....	1
12	8641-582-014	Lockwasher (end of motor rod) .....	1
28	9076-052-002	Collar, Shaft (w/set screws) .....	2
	9453-175-002	Pulley, Motor WCVD-75,WCVD-55 .....	1
	9053-077-001	Bushing, Split Taper WCVD-55,WCVD-75 .....	1
	9545-018-021	Screw WCVD-75 .....	3
	9545-018-024	Screw WCVD-55 .....	3
1	9242-463-004	Hose, Overflow Vent 14" WCVD-75,WCVD-55 .....	1
2	9242-449-003	Hose, Overflow to drain WCVD-75, WCVD-55 .....	1
3	9453-176-005	Pulley, Driven WCVD-55,WCVD-75 .....	1
4	9053-078-002	Bushing, Taper WCVD-55,WCVD-75 .....	1
5	9545-029-011	Screw .....	3
6	8641-582-003	Lockwasher .....	3
7	9040-079-003	Drive Belt WCVD-75, .....	1
7	9040-079-002	Drive Belt WCVD-55 .....	1
8	9081-140-001	Channel, Rear WCVD-75 .....	1
8	9081-109-001	Channel, Rear WCVD-55 .....	1
9	9545-008-026	Screw .....	4
9	8640-399-008	Nut, Spring .....	4
10	8654-029-000	Clamp, Hose .....	2
11	9341-046-001	Link, Chain .....	1
	9497-222-004	Rod, Motor Mtg. WCVD-55,WCVD-75 .....	1

\* Not Illustrated

# CYLINDER, WATER SEALS & BEARING HOUSING GROUP

## 18 LB. , 25 LB. , 40LB

Key	Part Number .....	Description
*	9803-179-002	Housing, Bearing- Assembly (includes items #2-#6)WCVD-25, ... 1
2	9241-169-002	Housing, Bearing ..... 1
3	9036-159-002	Bearing, Front ( LARGE ) ..... 1
4	9036-159-001	Bearing, Rear ( SMALL ) ..... 1
5	9538-158-001	Spacer, Bearing ..... 1
6	9487-238-001	Ring, Bearing Retainer ( internal type ) ..... 1
*	9803-182-001	Housing, Bearing- Assembly (includes items #2-#6) WCVD-18 ..... 1
2	9241-174-002	Housing, Bearing ..... 1
3	9036-159-001	Bearing, Front ( LARGE ) ..... 1
4	9036-159-003	Bearing, Rear ( SMALL ) ..... 1
5	9538-161-001	Spacer, Bearing ..... 1
6	9487-238-002	Ring, Bearing Retainer ..... 1
*	9803-186-001	Housing, Bearing- Assembly (includes items #2-#6) WCVD-40 ..... 1
2	9241-180-002	Housing, Bearing ..... 1
3	9036-159-005	Bearing, Front( LARGE ) ..... 1
4	9036-159-004	Bearing, Rear ( SMALL ) ..... 1
5	9538-167-001	Spacer, Bearing ..... 1
6	9487-238-003	Ring, Bearing Retainer ( Internal ) ..... 1
7	9732-137-001	Back Assy, Tub 2 piece WCVD-18 ..... 1
7	9732-137-002	Back Assy, Tub 2 piece WCVD-25 ..... 1
7	9732-137-003	Back Assy, Tub 2 piece WCVD-40 ..... 1
9	9532-140-004	Seal, Primary WCVD-18 ..... 1
8	9532-140-005	Seal, Secondary WCVD-18 ..... 1
8	9532-140-003	Seal, Secondary WCVD-25 ..... 1
9	9532-140-002	Seal, Primary WCVD-25 WCVD-40 ..... 1
8	9532-140-006	Seal, Secondary WCVD-40 ..... 1
10	9950-047-001	Ring, Seal Mounting WCVD-18 ..... 1
10	9950-042-001	Ring, Seal Mounting WCVD-25 ..... 1
10	9950-048-001	Ring, Seal Mounting WCVD-40 ..... 1
11	9487-261-001	Tub Back Mating Ring WCVD-18 ..... 1
11	9487-261-002	Tub Back Mating Ring, WCVD-25 ..... 1
11	9487-261-003	Tub Back Mating Ring, WCVD-40 ..... 1
12	9545-017-009	Bolt, 1/2" Tub End of Bearing Housing ( 1/2" x 1 1/4" ) WCVD-25 .. 6
12	8640-417-002	Nut 1/2' ..... 6
12	8641-582-016	Lockwasher 1/2" ( ext. tooth) ..... 6
12	9545-060-001	Bolt 5/8-11x1 1/2" Tub end of bearing housing WCVD-40 ..... 6
12	8640-425-001	Nut 5/8" ..... 6
12	8641-582-018	Lockwasher 5/8" ..... 6
13	9991-049-002	Support Arm Assy, Bearing Housing WCVD-18 ..... 6
13	9991-048-002	Support Arm Assy., Bearing Housing WCVD-25 ..... 6
13	9991-056-002	Support Arm Assy, Bearing Housing WCVD-40 ..... 6
16	9545-029-003	Bolt Pulley End of Bearing Housing ( 3/8" x 1 1/2" ) WCVD-25 .... 6
16	8640-415-004	Nut, Flange Locking 3/8" WCVD-25 ..... 6
16	9545-059-003	Bolt Pulley end of bearing housing 7/16-14x2" WCVD-40 ..... 6
16	8640-416-005	Nut, Flange Locking 7/16" WCVD-40 ..... 6
15	9453-168-003	Puley, Driven WCVD-40 ..... 1
15	9453-168-004	Pulley, Driven WCVD-25 ..... 1
15	9908-041-002	Pulley, Driven WCVD-18 ..... 1
*	9487-234-001	Ring, Tolerance WCVD-25 Between shaft and pulley ..... 1
*	9487-234-002	Ring, Tolerance WCVD-18 Between shaft and pulley ..... 1
*	9487-234-003	Ring, Tolerance WCVD-40 Between shaft and pulley ..... 1
16	8641-581-026	Washer 1/2" WCVD-18,WCVD-25 ..... 1
17	9545-017-009	Bolt 1/2-13 x 1 1/4") ..... 1
18	8641-582-016	Lockwasher 1/2" Ext. tooth ..... 1
16	8641-060-001	Bolt 5/8-11x11/2" WCVD-40 ..... 1
17	8641-581-032	Washer 5/8" ..... 1
18	8641-582-018	Lockwasher 5/8 Ext. tooth ..... 1

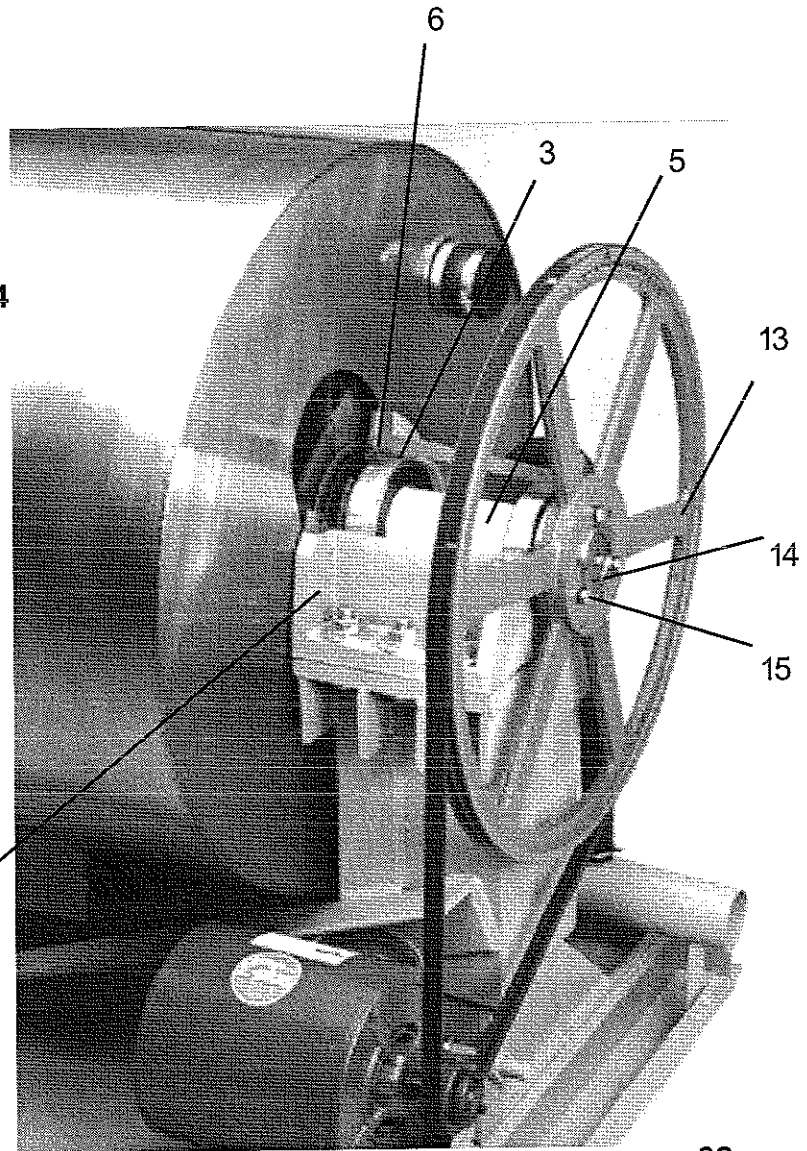
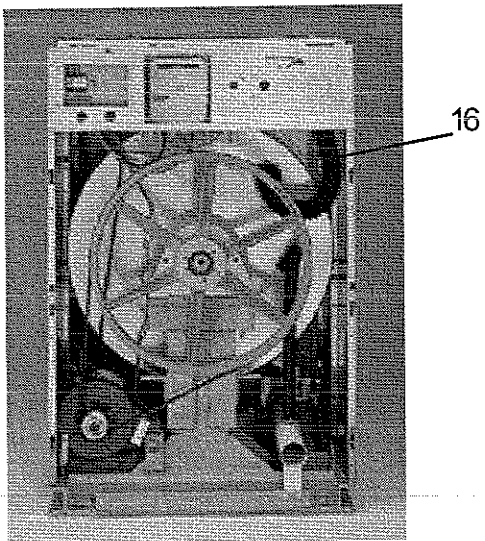
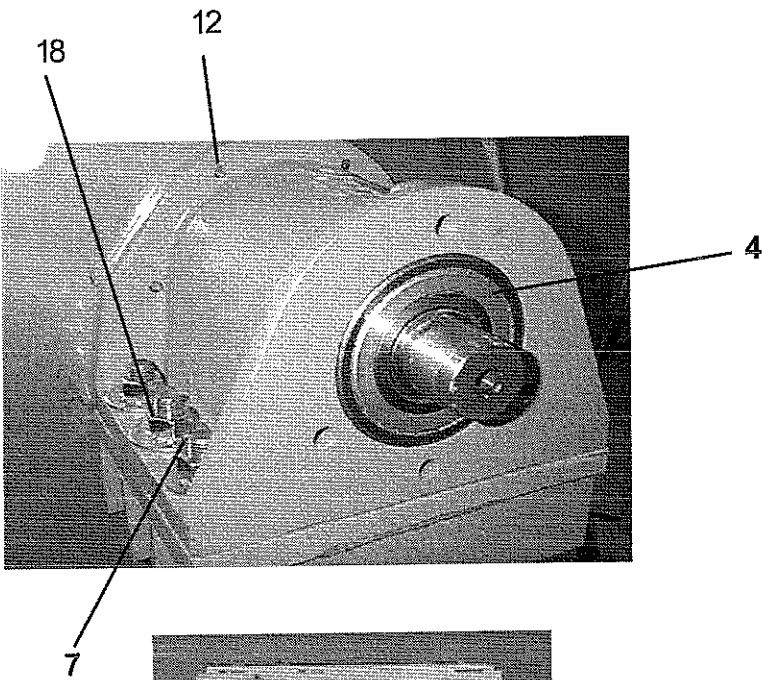
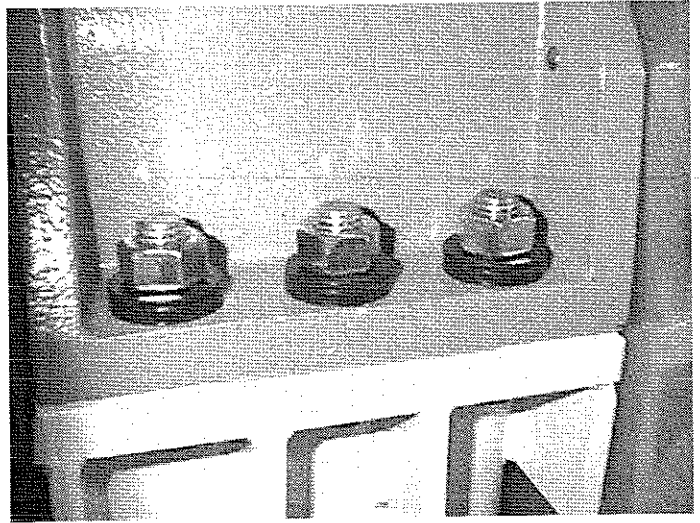
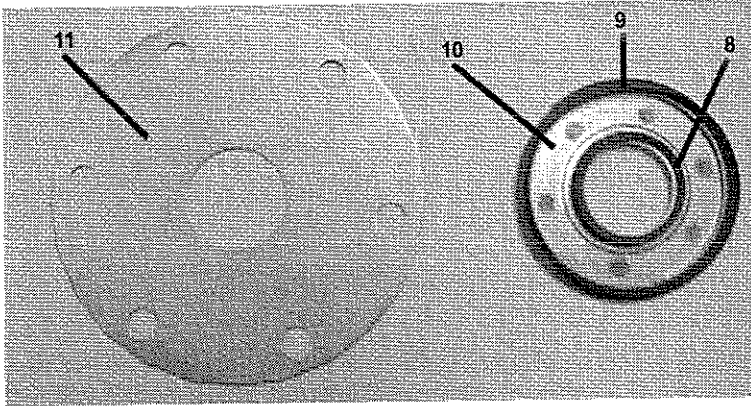

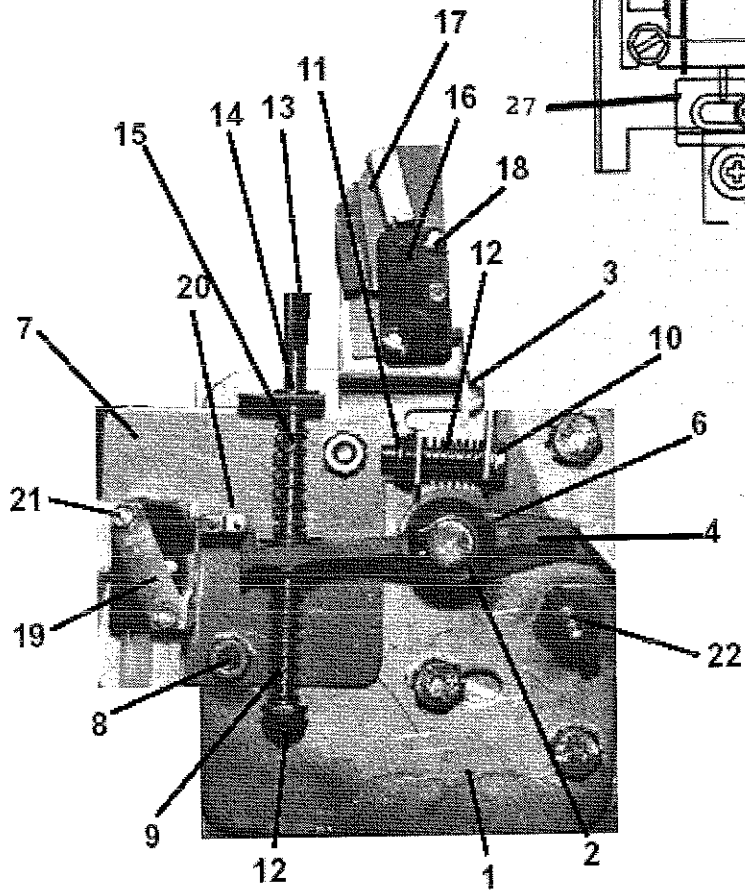
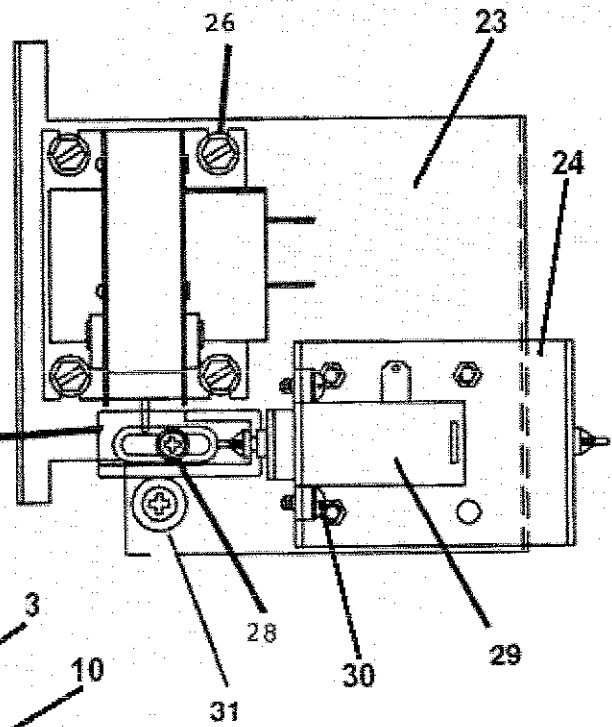
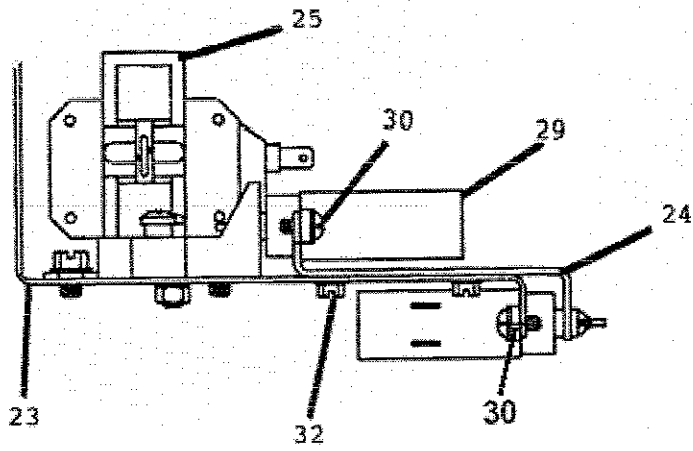

## LOADING DOOR GROUP 25LB.,40LB.,55LB.

WCVD25KCS, WCVD40KCS, WCVD55KCS

Key	Part Number	Description	
*	9960-274-002	Loading Door, Complete (includes 1 thru 10)	1
1	9487-265-001	Loading Door, Ring	1
2	9206-419-001	Gasket, Loading Door	1
3	9635-016-001	Window, Loading Door	1
*	9913-134-003	Shaft Assy, Locking (includes 4 thru 7)	1
4	9537-195-002	Shaft, Door Locking	1
5	9095-040-001	Cam, Locking	1
6	9451-181-005	Pin, Groove (1 1/4)	1
7	9451-181-004	Pin, Groove (3/4)	1
8	9534-360-002	Spring, Lock Cam	1
9	9244-080-003	Handle, Door	1
*	9451-181-006	Pin, Door Handle (groove)	1
10	9955-029-002	Loading Door Hinge Assy ( mounts to Tub Front )	1
*	9545-014-009	Screw, Hinge Mtg 5/16" x 3/4"	3
*	8641-582-009	Lockwasher 5/16" Ext tooth	3
*	9552-036-001	Shim, Loading Door Hinge, Thin	AR
*	9552-036-002	Shim, Loading Door Hinge, Thick	AR
11	9451-184-004	Door Hinge Pin(mounts inside Loading Door Hinge Assy)	1
*	8649-031-000	Ring, Retaining ( snap ring ext )	1
12	9079-122-002	Loading Door Hinge Clamp ( mounts to door ring )	1
13	9545-056-001	Screw, Loading Door Mtg 5/16" Theard Forming)	3
14	9950-060-001	Ring, Masking	1
*	9059-063-002	Band, Edge ( mounts to Front Panel )	1
*	8640-413-002	Nut, Kepsfor mounting masking ring	4
*	9627-791-003	Wiring Harness doorlock safety switch	1
*	9801-089-001	Switch assembly Door Closure includes all **	1
**	9041-087-001	Switch Box	1
**	9053-067-003	Bushing Insulating	1
**	9539-461-007	Switch Micro	1
**	9550-159-001	Switch Shield	1
**	8640-401-001	Nut Special Twin #4-40	1
**	9545-020-001	Screw 4-40x5/8	2
**	9008-004-001	Door Switch Actuator	1

\* Not Illustrated



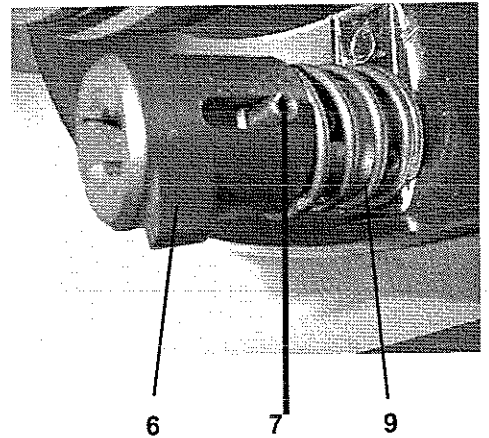
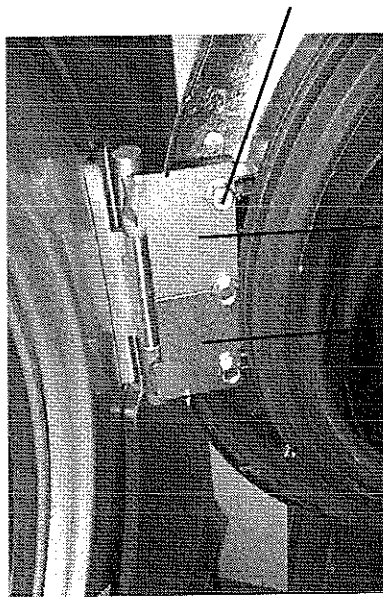

# 16

# 12

# 13

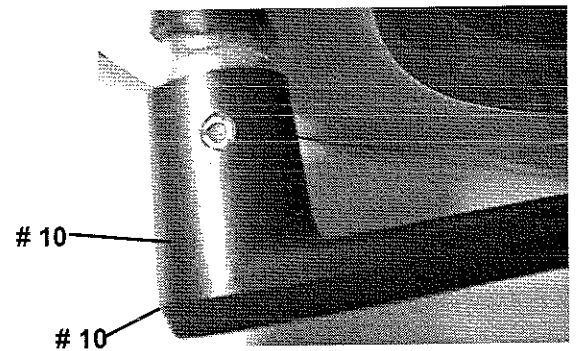
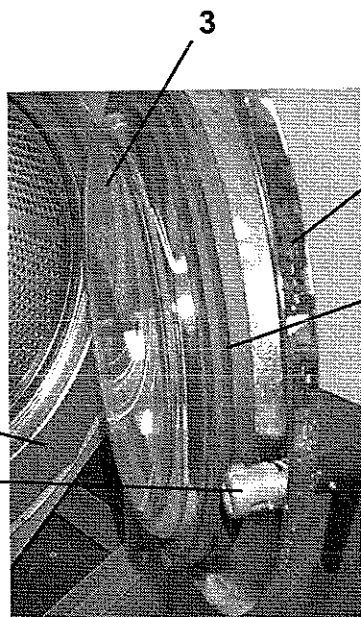
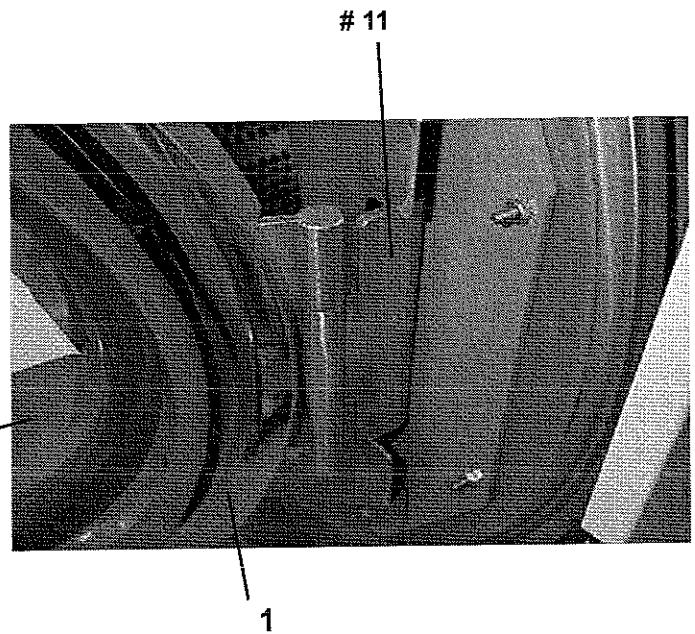



# LOADING DOOR GROUP 18LB.

WCVD18KCS

Key	Part Number	Description	
*	9960-273-001	Loading Door, Complete (includes 1 thru 10) .....	1
1	9487-264-001	Loading Door, Ring .....	1
2	9206-411-002	Gasket, Loading Door .....	1
3	9635-018-001	Window, Loading Door .....	1
*	9913-134-003	Shaft Assy, Locking (includes 4 thru 7) .....	1
4	9537-195-002	Shaft, Door Locking .....	1
5	9095-040-001	Cam, Locking .....	1
6	9451-181-005	Pin, Groove (1 1/4) .....	1
7	9451-181-004	Pin, Groove (3/4) .....	1
8	9534-360-002	Spring, Lock Cam .....	1
9	9244-080-003	Handle, Door .....	1
*	9451-181-006	Pin, Door Handle (groove) .....	1
10	9955-029-002	Loading Door Hinge Assy ( mounts to Tub Front ) .....	1
*	9545-014-009	Screw, Hinge Mtg 5/16" x 3/4" .....	3
*	8641-582-009	Lockwasher 5/16" Ext tooth .....	3
*	9552-036-001	Shim, Loading Door Hinge, Thin .....	AR
*	9552-036-002	Shim, Loading Door Hinge, Thick .....	AR
11	9451-184-004	Loading Door Hinge Pin(mnts inside Loading Door Hinge Assy) .	1
*	8649-031-000	Ring, Retaining ( snap ring ext ) .....	1
12	9079-122-002	Loading Door Hinge Clamp (mounts to door ring) .....	1
13	9545-056-001	Screw, Loading Door Mtg (5/16" Theard Forming) .....	3
14	9950-059-001	Ring, Masking Assembly .....	1
*	9059-063-002	Band, Edge ( mounts to Front Panel ) .....	1
*	8640-413-002	Nut, Keps .....	4
15	9539-461-007	Switch Safety .....	1
16	9550-159-001	Safety switch shield .....	1
17	8220-062-027	Wires Red .....	1
18	8220-062-028	Wires Black .....	1
19	9801-089-001	Switch Assembly Complete Door Closure include 20-26 .....	1
20	9041-087-001	Switch Box .....	1
21	9053-067-003	Bushing Insulating .....	1
22	9539-461-007	Switch Micro .....	1
23	9550-159-001	Switch Shield .....	1
24	8640-401-001	Nut Special Twin #4-40 .....	1
25	9545-020-001	Screw 4-40x5/8 .....	2
26	9008-004-001	Door Switch Actuator .....	1

\* Not Illustrated

## WATER INLET GROUP

### WCVD-18,WCVD-25,WCVD-40,WCVD-55,WCVD-75

Key	Part Number	Description	
1	9379-183-003	Valve, Water Inlet (All except 75) .....	2
		(see Water Inlet Valve Breakdown for individual parts) .....	
1	9379-192-001	Valve Water Inlet WCVD-75 (dual outlet) .....	2
2	9379-194-001	Valve Water Inlet WCVD-75 (Single outlet) .....	2
*	9545-008-026	Screw, Valve Mtg (ALL except 75) .....	4
3	8640-399-009	Nut, Spring (All except 75) .....	4
*	9545-064-001	Screw, Valve M4x0.7x8mm WCVD-75 .....	8
4	9208-049-001	Guard Water valve terminal ALL .....	1
5	9610-001-001	Vacuum Breaker ALL .....	1
6	9029-069-001	Bracket, Vacuum Breaker ALL .....	1
7	9545-008-026	Screw ALL .....	4
8	9550-186-001	Shield over Water Valves Plastic (All except 75) .....	1
9	9242-458-003	Hose, Vacuum Breaker to Tub ALL .....	1
10	8654-117-014	Clamp, Vacuum Breaker End ALL .....	1
11	8654-117-009	Clamp, Tub End ALL .....	1
12	9242-453-018	Hose, Vac. Brkr. to Disp.29" WCVD-55 .....	1
12	9242-453-019	Hose, Vac. Brkr. to Disp.26" WCVD-55 .....	1
13	9242-453-020	Hose, Hot Valve to Vac. Brkr 18" ALL .....	1
13	9242-453-020	Hose, Hot Valve to Tub 18" ALL .....	1
14	9242-453-020	Hose, Cold Valve to Vac. Brkr 18" ALL .....	1
14	9242-453-020	Hose, Cold Valve to Tub 18" ALL .....	1
12	9242-453-022	Hose, Vac. Brkr. dispenser 43" WCVD-75 .....	3
13	9242-453-009	Hose, (valve to vac. Brkr) 23" WCVD-75 .....	4
14	8654-029-000	Clamp, Hose-Spring ( overflow from drain to tub back ) .....	2
15	8654-117-015	Clamp, Hose-Worm .....	10
16	9475-002-002	Flow restrictor ( All except 75 ) .....	2
17	9475-002-003	Flow restrictor WCVD-75 .....	3
18	5198-211-004	Circuit Breaker ( optional) .....	1
18	9200-001-002	Fuseholder .....	1
18	8636-018-001	Fuse 1.5 amp ( All except 75 ) .....	1
18	8636-018-004	Fuse 2.5 amp WCVD-75 .....	1

\* Not Illustrated

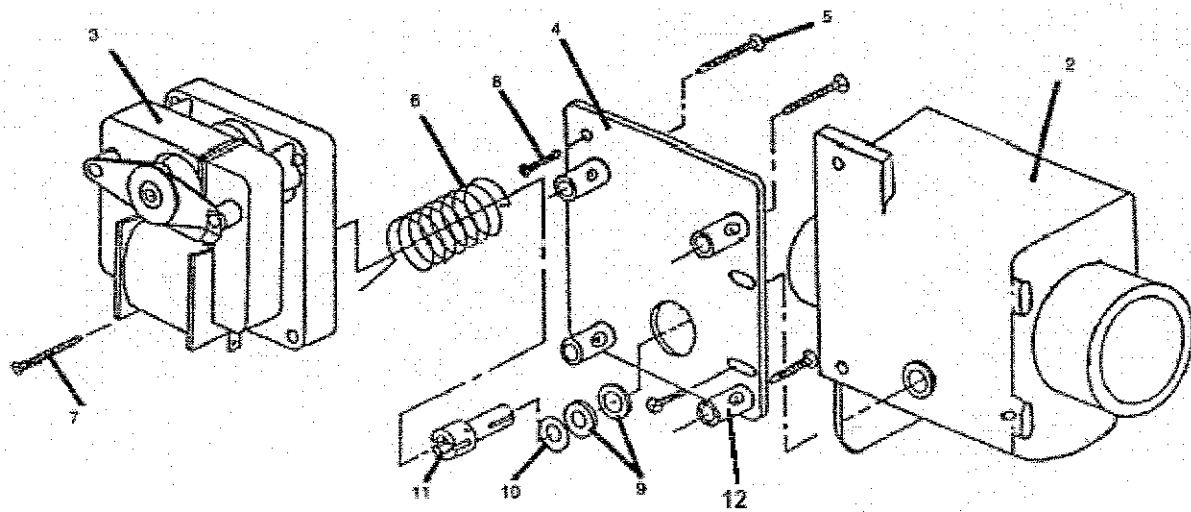
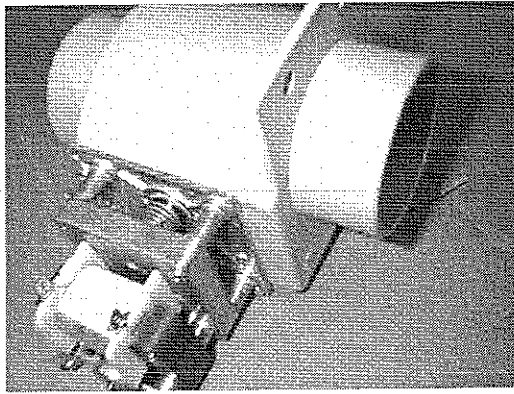

## SCHEMATICS, LABELS AND DIAGRAMS ALL WCVD MODELS

9506-001-001	Wiring Diagram, WCVD-18-10
9506-003-001	Wiring Diagram, WCVD-25
9506-037-001	Wiring Diagram, WCVD-75
9506-009-001	Wiring Diagram, WCVD-55
9506-005-001	Wiring Diagram, WCVD-40
9506-007-001	Wiring diagram, WCVD-18-12
8507-330-001	Transient Voltage Surge Suppressor Infomational
8507-275-001	Instructions Spin Direction WCVD-55, WCVD-75
8507-274-001	Instructions Spin Direction WCVD-25, WCVD-40
8507-273-001	Instructions Spin Direction WCVD-18
9506-002-001	Wiring Schematic WCVD-18-10
9506-004-001	Wiring Schematic WCVD-25
9506-038-001	Wiring Schematic WCVD-75
9506-010-001	Wiring Schematic WCVD-55
9506-006-001	Wiring Schematic WCVD-40
9506-008-001	Wiring Schematic WCVD-18-12
8502-614-004	Label High Voltage Warning
8502-619-003	Label Fusing & Installation
8502-624-002	Label Door Opening Warning
8511-001-002	Label Quality

## CHASSIS AND DRAIN GROUP 55lb. ,75lb.

Key	Part Number	Description	
1	9945-105-002	Base Assy, Frame WCVD-55 .....	1
1	9945-125-002	Base Assy, Frame WCVD-75 .....	1
2	9930-138-001	Outer Tub Assy WCVD-55 .....	1
2	9930-144-001	Outer Tub Assy WCVD-75 .....	1
3	9950-053-002	Ring Assy, Tub Mtg-Front WCVD-55, WCVD-75 .....	1
4	9545-017-013	Screw Hexhead 1/2 x 2 WCVD-75,WCVD-55 .....	1
4	8640-417-005	Nut Whizlok WCVD-75 .....	1
4	8640-417-002	Nut Hex, 1/2 -13 WCVD-55 .....	3
4	8641-582-016	Lockwasher Exttooth 1/2" WCVD-55 .....	3
5	9545-017-013	Bolt, 1/2-13x2, Grd 5 Tub to Base WCVD-75, WCVD-55 .....	2
5	8641-581-026	Washer, Flat WCVD-55 .....	2
5	8641-581-026	Washer, Flat WCVD-75 .....	4
5	9552-013-001	Shim, Thin .....	4
5	9552-013-002	Shim, Thick .....	4
6	9379-187-001	Valve, Drain 3" OD WCVD-55,WCVD-75 .....	1
9	9915-126-002	Tube Assy, Drain WCVD-75 .....	1
9	9915-120-002	Tube Assy, Drain WCVD-55 .....	1
10	9545-030-002	Screw, Tube Mtg .....	2
11	9242-459-001	Hose, Tub to Drain Valve .....	1
12	9242-457-001	Hose, Drain Valve to Tube WCVD-55,WCVD-75 .....	1
13	8654-117-014	Clamp, Hose .....	5
*	9610-001-001	Vacuum Breaker WCVD-55, WCVD-75 .....	1
*	9029-069-001	Bracket, Vacuum Breaker WCBVD-55, WCVD-75 .....	1
*	9545-008-026	Screw #10Bx 1/2 .....	4
15	8654-117-001	Clamp .....	4
16	9732-108-002	Dispenser WCVD-55, .....	1
17	9206-416-001	Gasket, Dispenser WCVD-55 .....	1
18	9242-450-001	Hose, Dispenser to Tub WCVD-55 .....	1
19	8654-117-008	Clamp, Dispenser Hose WCVD-55 .....	2
20	9807-091-001	Soap Box Assembly Complete SS WCVD-75 .....	1
21	9206-425-001	Soap Box mounting Gasket WCVBD-75 .....	1
22	9987-104-001	Lid Assembly soap box WCVD-75 .....	1
23	9545-012-017	Lid screws #10-32x1/2 SS WCVD-75 .....	1
24	8640-413-006	Nut Hex Elasticstop #10-32 SS WDCV-75 .....	6
25	9538-157-019	Spacer Plastic #10x1/2 WCVD-75 .....	4
26	9029-148-001	Bracket Soap box mounting WCVD-75 .....	1
27	9574-252-002	Softner siphon tube WCVD-75 .....	1
28	9475-002-003	Flow restrictors WCVD-75 .....	3
29	9974-007-002	Front Ass'y, Tub WCVD-55, WCVD-75 .....	1
30	9950-055-001	Ring Ass'y, Clamp (tub front to outer tub) WCVD-55,WCVD-75 .....	1
31	9545-029-009	Screw, 3/8-16x3 WCVD-55, WCVD-75 .....	1
32	8640-415-001	Nut, Hex 3/8-16 WCVD-55, WCVD-75 .....	1
33	9206-421-002	Gasket, Tub Front WCVD-55, WCVD-75 .....	1
34	8615-104-039	Pipe Plug WCVD-55, WCVD-75 .....	2
35	9242-449-003	Hose, Overflow WCVD-55, WCVD-75 .....	1
36	8654-029-000	Clamp, Hose WCVD-55, WCVD-75 .....	2

\* Not Illustrated

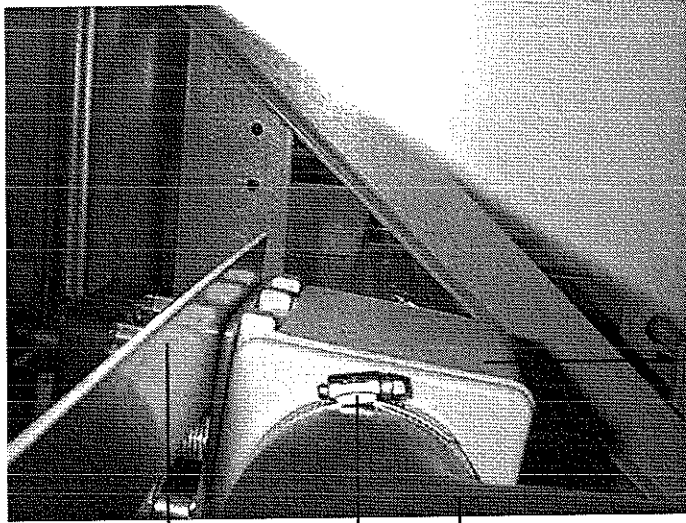

10

16

14

9

2

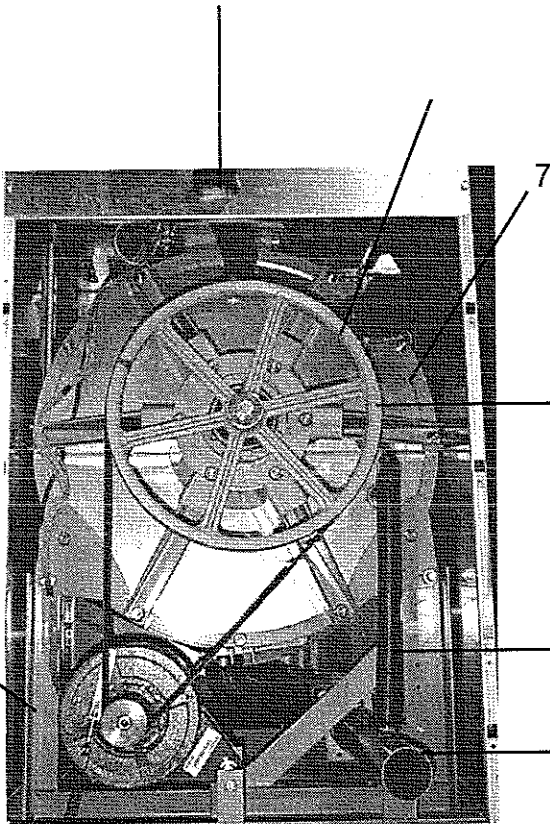
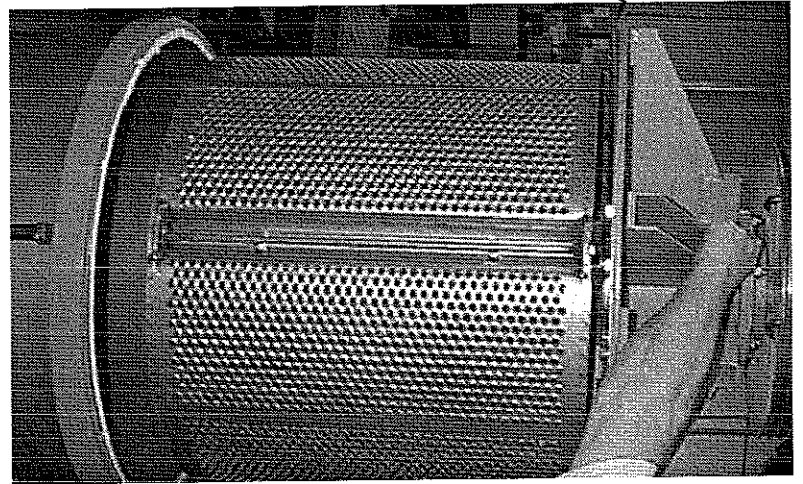

1

7

12

## CONTROL PANEL GROUP

WCVD-75, WCVD-55 , WCVD-40 ,WCVD-25 ,WCVD-18-10 , WCVD-18-12

Key	Part Number	Description .....	
1	9989-473-001	Panel Control Assembly(panel only)WCVD-18-10,WCVD-18-12..	1
1	9989-474-001	Panel Control Assembly (panel only) WCVD-25 .....	1
1	9989-475-001	Panel Control Assembly (panel only) WCVD-40 .....	1
1	9989-476-001	Panel Control Assembly (panel only) WCVD-55,WCVD-75 .....	1
*	9545-008-026	Screw, Hxwshrhdundct #10Bx 1/2" .....	4
3	9467-024-001	Post Locator Top .....	2
*	8640-411-003	Nut Hexkeps #6-32 .....	2
*	9355-001-001	Locator Panel.....	2
6	9545-008-023	Screw FillHDCR 10Bx1/2" .....	2
7	9538-178-001	Spacer Pushbutton (Micro) .....	1
8	9486-150-001	Retainer Pushbutton ( Micro) .....	1
9	8640-424-002	Nut Hexelasticstop #4-40 .....	2
10	9035-060-001	Pushbutton Control (coin) .....	1
2	9185-008-001	Filler Pushbutton Control .....	4
11	9473-004-001	PCB assembly Control /Display .....	1
12	9538-157-018	Spacer Plastic #6x9/16 .....	5
13	8640-411-003	Nut Elasticstop #6-32.....	5
14	9627-797-001	Harness LEDPCB .....	1
15	9627-791-003	Harness Doorlock WCVD-18,WCVD-25 .....	1
15	9627-791-004	Harness Doorlock WCVD-40,WCVD-55,WCVD-75 .....	1
16	9473-004-001	PCB assembly Mode lights .....	1
17	9538-157-018	Spacer Plastic #6x9/16 .....	2
18	8640-411-003	Nut Hexkeps #6-32 .....	2
19	9794-001-001	Light, LED,ADD BLEACH Assembly .....	1
20	9538-157-018	Spacer Plastic #6x9/16 .....	2
21	8640-411-003	Nut Hexeps #6-32 .....	2
*	9732-122-001	Kit, Coin Box W/Hardware .....	1
22	9412-114-001	Nameplate, Control Panel (one piece) WCVD-40 .....	1
22	9412-113-001	Nameplate,Control Panel (one piece) WCVD-25 .....	1
22	9412-112-001	Nameplate,Control Panel (one piece) WCVD-18 .....	1
22	9412-115-001	Nameplate,Control Panel (one piece) WCVD-55 .....	1
22	9412-130-001	Nameplate,Control Panel (one piece) WCVD-75 .....	1
.	9922-011-001	Solenoid Ass'y, Door Locking (see Door Lock Group for parts breakdown )	
*	8640-412-005	Hex Nuts ( mounting solenoid assy. to control panel ) .....	4
23	8612-001-001	Battery .....	1

## Electrical Components - Top Compartment

Key	Part Number	Description	
1	9857-154-001	Trough Assy, Controls (all parts below #2 - #43 & trough)	WCVD-55
1	9857-151-001	Trough Assy, Controls(all parts below #2-#43 & trough)	WCVD-25
1	9857-150-001	Trough Assy, Controls(all parts below #2-#43 & trough)	WCVD-18-12
1	9857-149-001	Trough Assy, Controls(all parts below #2-#43 & trough)	WCVD-18-10
1	9857-152-001	Trough Assy, Controls (all parts below #2 - #43 & trough)	WCVD-40
1	9857-160-001	Trough Assy, Controls (all parts below #2 - #43 & trough)	WCVD-75
2	9839-015-001	Trough only ALL	1
3	9545-008-026	Screw, Trough Sides ALL	4
4	8641-582-006	Lockwasher Exttooth #10 ALL	4
5	9003-270-001	Angle Support Trough WCVD-18,WCVD-25	1
5	9003-271-001	Angle Support Trough WCVD-40,WCVD-55	1
6	9545-008-026	Screw, Trough Bracket WCVD-18,WCVD-25,WCVD-40,WCVD-55	4
7	8711-004-001	Transformer, Control (Operating Voltage to 115 volts) ALL	1
9	9545-045-001	Screw, Mtg #8Bx1/4"	2
10	8641-582-005	Lockwasher	2
11	8220-001-282	Wire Assembly Red 20" WCVD-18, WCVD-25	2
11	8220-062-025	Wire Assembly Red 28" WCVD-40, WCVD-55	2
11	8220-062-032	Wire Assembly Red 41" WCVD-75	2
12	8639-621-007	Screw GRN. #10-32x 1/2"	1
13	8641-582-006	Lockwasher #10	1
14	8652-130-037	Lug, Grounding	1
15	9473-006-001	PCB assembly Relay Main ALL EXCEPT 18-10 NOT USE	1
16	9538-157-011	Spacer Plastic #8x3/8"	6
17	8640-411-003	Nuts Hexkeys #6-32	6
18	9627-796-001	Harness Drain/Therm/Sol WCVD-18,WCVD-25	1
18	9627-796-002	Harness Drain/Therm/Sol WCVD-40,WCVD-55,WCVD-75	1
19	9627-795-001	Harness P19/Water Valve WCVD-18,WCVD-25	1
19	9627-795-002	Harness P19/Water Valve WCVD-40,WCVD-55,WCVD-75	1
20	9627-794-001	Harness P8/P16 ALL	1
21	9627-793-001	Harness P20/P21 ALL	1
22	8220-064-023	Wire Assembly Yel 32" WCVD-18,WCVD-25,WCVD-40,WCVD-55	2
22	8220-064-040	Wire Assembly Yel 64" WCVD-75	2
23	9053-067-002	Bushing , Wire 7/8 ALL	2
24	9527-002-002	Standoff Twistlock ALL	3
25	9527-002-003	Standoff Twistlock ALL	2
26	9483-004-002	Dynamic Braking Resistor WCVD-18-10,WCVD-18-12,	1
26	9483-004-002	Dynamic Braking Resistor WCVD-25,WCVD-40,	2
26	9483-004-003	Dynamic Braking Resistor WCVD-55, WCVD-75	2
27	9545-012-008	Screws #10-32x1/2" (pnhdcr)	4
28	8640-413-002	Nuts, #10-32 UNF 2B	4
29	8220-117-001	Wire Assembly Jumper Blk. ALL except wcvd-18	2
29	8220-118-001	Wire Assembly Jumper BLK. WCVD-18	2
30	9545-044-006	Screw #6-32x5/16"	4
31	8640-411-003	Nuts Hex #6-32	4
32	9897-034-001	Terminal Block Assy, POWER ALL	1
33	9545-045-007	Screw, Mtg 8Bx3/8"	2
34	9558-027-001	Strip, Terminal Marker WCVD-18,WCVD-40,WCVD-55,WCVD-75	1
34	9558-027-002	Strip, Terminal Marker WCVD-25	1
35	9539-457-002	Switch, Pressure WCVD-18	1
35	9539-457-001	Switch, Pressure WCVD-40,WCVD-25,WCVD-55	1
35	9539-488-001	Switch, Pressure WCVD-75	1
36	9545-045-001	Screw, Mtg #8Bx1/4" WCVD-18,WCVD-25,WCVD-40	2
36	9545-008-026	Screw, Mtg. WCVD-55, WCVD-75	2



## Electrical Components - Top Compartment CON'T

Key	Part Number	Description	
37	9627-800-001	Harness P5/Pressure WCVD-18.....	1
37	9627-801-001	Harness P5/Pressure WCVD-25.....	1
37	9627-803-001	Harness P5/Pressure WCVD-55,WCVD-75.....	1
37	9627-802-001	Harness P5/Pressure WCVD-40.....	1
38	8711-009-001	Transformer, (Step Down) 120/2.3 VAC&24 VAC ALL.....	1
39	9545-008-026	Screw, Transformer Mtg #10Bx1/2".....	4
40	8641-582-006	Lockwasher #10 exttooth.....	4
41	8220-001-231	Wire Assembly BLK/Blu.....	1
42	9631-381-018	Wire Assembly Red 7".....	1
43	8220-090-009	Wire Assembly Blu/Wht.....	1
44	5198-211-004	Circuit Breaker.....	(optional)
45	9200-001-002	Fuseholder.....	1
46	8636-018-001	Fuse WCVD-18,WCVD-25,WCVD-40,WCVD-55 1.5amp.....	1
46	8636-018-004	Fuse WCVD-75 2.5amp.....	1
47	9375-007-003	Variable Frequency Drive WCVD-40.....	1
47	9375-009-002	Variable Frequency Drive WCVD-55.....	1
47	9375-007-002	Variable Frequency Drive WCVD-25.....	1
47	9375-005-002	Variable Frequency Drive WCVD-18-12.....	1
47	9375-004-002	Variable Frequency Drive WCVD-18-10.....	1
47	9375-009-005	Variable Frequency Drive WCVD-75.....	1
48	8502-716-001	Label Fuse 1.5 amp.....	1
48	8502-716-002	Label Fuse 2.5 amp.....	1
49	9897-033-002	Terminal Block Assembly WCVD-25.....	1
51	9545-031-010	Screw 6ABx3/4 WCVD-25.....	2
52	9627-747-003	Wiring Harness Power Terminal WCVD-25,WCVD-40.....	1
52	9627-747-002	Wiring Harness Power Terminal WCVD-55, WCVD-75.....	1

## COIN HANDLING GROUP

WCVD-18, WCVD-25, WCVD-40, WCVD-55, WCVD-75

Key	Part Number	Description	
1	9942-029-001	Vault, Assy WCVD-18 .....	1
1	9942-030-001	Vault, Assy WCVD-25 .....	1
1	9942-030-002	Vault, Assy WCVD-40 .....	1
1	9942-030-003	Vault, Assy WCVD-55 .....	1
1	9942-030-004	Vault, Assy WCVD-75 .....	1
*	9545-008-026	Screw, 10Bx 1/2" Vault Mtg .....	2
*	9545-008-031	Screw, 10AB x 1/2" Vault Mtg .....	2
8	9119-028-001	Chute Assy.WCVD-75 .....	1
8	9119-029-001	Chute Assy.WCVD-18,WCVD-25,WCVD-40,WCVD-55 .....	1

NOTE: COIN BOX AND HARDWARE KIT AND COIN BOX LOCK NOT INCLUDED WITH MACHINE.

2	9732-122-001	Kit, Coin Box W/Hardware (includes 3 thru 6) .....	1
3	9349-033-001	Latch, Coin Box .....	1
4	8641-569-002	Washer, Wave .....	1
5	8641-583-001	Washer, Keeper .....	1
6	8641-581-008	Washer, Spacer- Thick .....	2
6	8641-581-010	Washer, Spacer- Thin .....	4
7	8650-012-003	Lock, Coin Box (w/key not included with 9732-122-001) .....	1
*	9545-008-001	Screw, Chute Mtg .....	1
11	9119-025-002	Coin Acceptor chute without penny rejector (standard) .....	1
*	9021-007-001	Dual acceptor (dollar/quarter US) optional see below .....	1
*	9545-020-002	Screw, Acceptor Mtg .....	4
*	8640-424-002	Nut .....	4
10	9732-126-001	Switch, Coin ( fits single coin drop) .....	1
12	9119-025-001	Coin Acceptor chute with penny rejector (optional) .....	optional
13	9486-133-001	Button Coin Return Retainer .....	1
*	9021-007-001	Acceptor Dual Coin .....	optional
*	9922-008-001	Coin Blocking Solenoid assy (** included ) .....	1
**	9536-079-001	Solenoid coin blocking .....	1
**	9534-362-001	Spring coin blocking .....	1
**	9545-039-001	Screw,Blocking assy mtg. ....	2
**	8641-579-001	Lockwashers .....	2
9	9021-001-001	Coin Acceptor Complete w/coin blocking solenoid .....	1

\* Not Illustrated

