

STACKED DRYER

Repair Parts List

MODEL NUMBER
MLG32PDAWW

When requesting service or ordering parts, always provide the following information:

- Product Type
- Part Number
- Model Number
- Part Description

MAYTAG®

©2005 Maytag Services

Section: CONTROL DOOR ASSEMBLY

Model: MLG32PDAWW

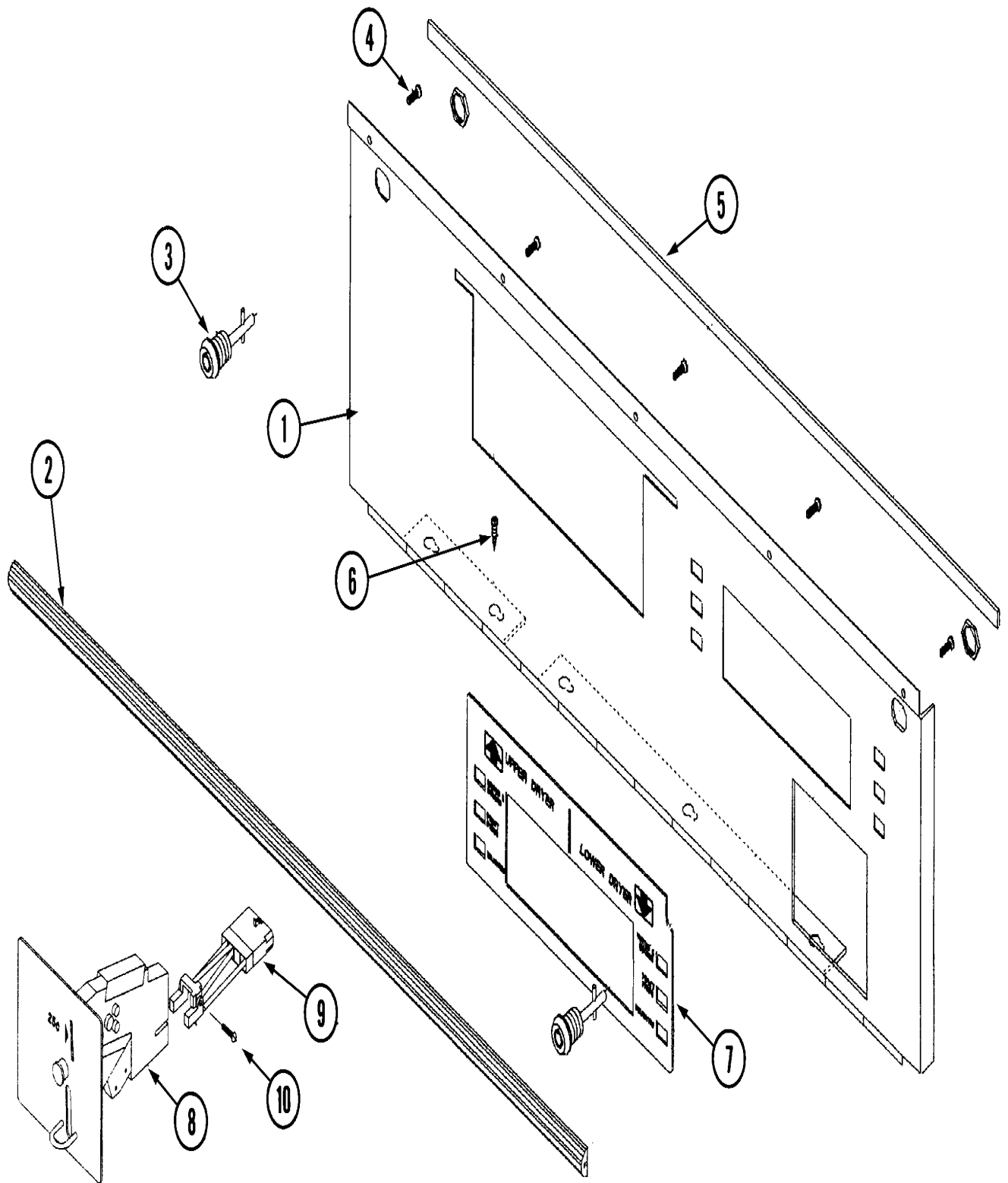

CD12-13

Section: CONTROL DOOR ASSEMBLY

No.	Part No.	Description	Series	Qty
0	-----	NOT REQUIRED PART OR SEE NOTE Note: ORDER PARTS FROM AMERICAN DRYER CORP. AT 508-678-9000	10	1
-	A311576	CONTROL DOOR, LOWER	21	1
1	A881977	CONTROL DOOR ASSY. (WHT)	10	1
2	A180224	TRIM, TOP (CONTROL DOOR)	10	1
3	A160040	LOCK ASSY.	10	2
4	A150201	SCREW, MACHINE (#10-32 X 1/4") Note: MACHINE SCREW (#10 X 1/4")	10	5
5	A117605	GASKET	10	3
6	A150301	SCREW, TEK (#8-18 X 7/16 PH Note: SCREW (#8-18 X 7/16")	10	5
7	A114075	LABEL, DISPLAY (MAYTAG)	10	1
8	A881935	COIN DROP ASSY.	10	1
-	A125171	SINGLE COIN .25 ACCEPTOR/HANKE	21	1
9	A125157	SWITCH, OPTIC (HANKE)	10	1
10	A150002	SCREW, MACHINE (RD.HD.) Note: SCREW (#6-32 X 1")	10	1
-	A801093	CONTROL DOOR WELDMENT, TOP	21	1

*Color Code (-)=Not Shown #=Series, Serial Prefix or Run No., N=Not Available

Section: CONTROL BOX ASSEMBLY

Model: MLG32PDAWW

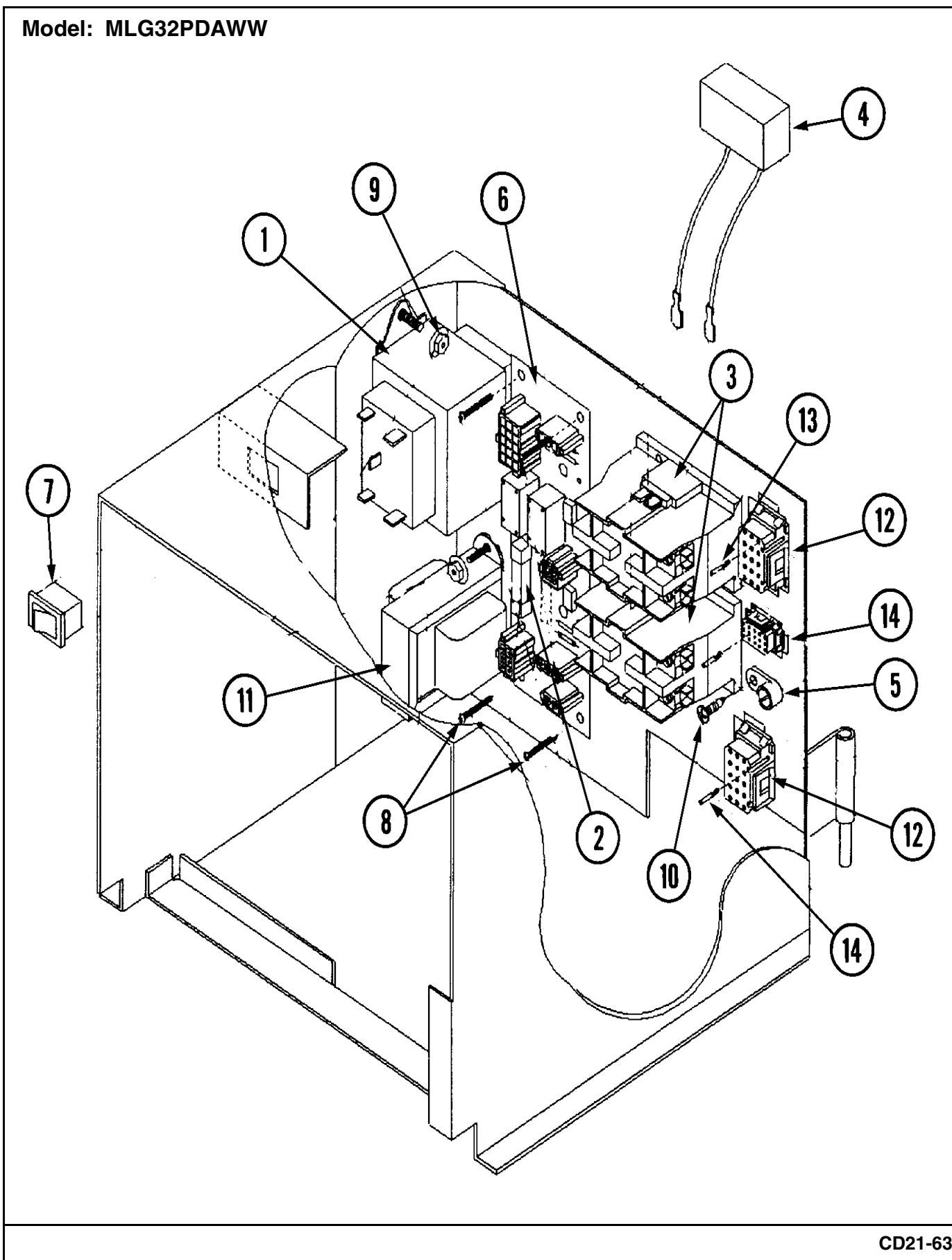

CD21-63

Section: CONTROL BOX ASSEMBLY

No.	Part No.	Description	Series	Qty
0	-----	NOT REQUIRED PART OR SEE NOTE Note: ORDER PARTS FROM AMERICAN DRYER CORP AT 508-678-9000		1
1	A132068	TRANSFORMER (MULTI-TAP)		1
2	A136057	FUSE, 1/2-AMP SLO-BLO		1
3	A132475	CONTACTOR		2
4	A824828	RC NETWORK W/CONNECTOR		2
5	A121010	LUG, GROUND (L-70)		1
6	A137241	BOARD, INTERCONNECT		1
7	A122401	SWITCH, ROCKER		1
8	A150005	SCREW, PHILL (6-32 X 1/4")RND Note: SCREW (PH#6-32 X 1/4")		4
9	A151001	NUT, PAL (#8-32)		4
10	A150300	SCREW (#10-32 X 1/2" PH ROUND Note: SCREW (HEX HD #10-16 X 1/2")		3
11	A821982	TRANSFORMER (25V MICRO)		1
12	A122626	CONNECTOR, SOCKET (15-PIN)		1
13	A122705	TERMINAL, SOCKET (ONLY)		15
14	A122631	CONNECTOR, SOCKET (6 PIN)		1

*Color Code (-)=Not Shown #=Series, Serial Prefix or Run No., N=Not Available

Section: UPPER FRONT PANEL ASSEMBLY

Model: MLG32PDAWW

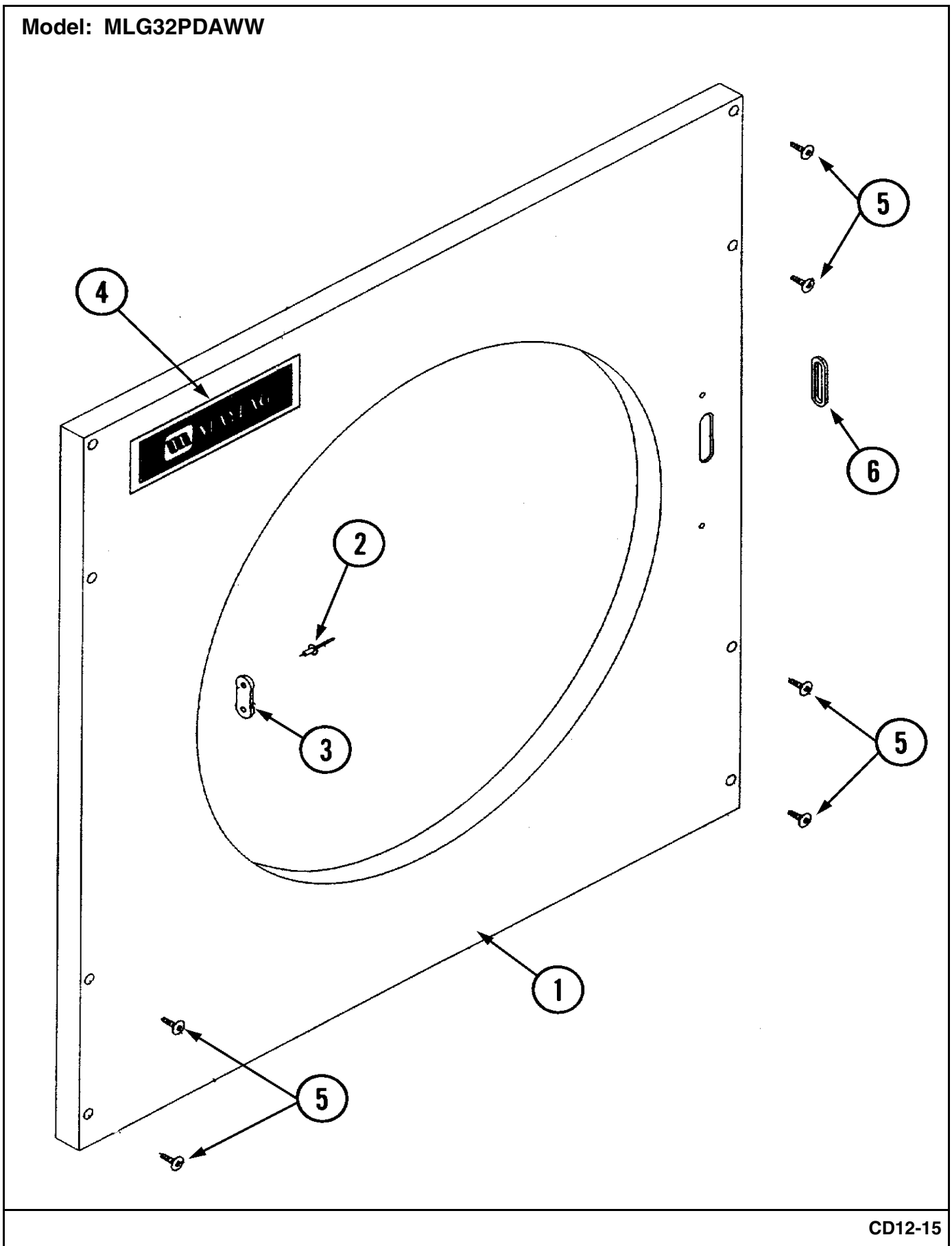

CD12-15

Section: UPPER FRONT PANEL ASSEMBLY

No.	Part No.	Description	Series	Qty
0	-----	NOT REQUIRED PART OR SEE NOTE Note: ORDER PARTS FROM AMERICAN DRYER CORP AT 508-678-9000.		1
1	A881973	PANEL, FRONT (UPR-WHT)	10	1
2	A154215	RIVET, POP (5/32")	10	2
3	A170330	LATCH, DOOR (FRICTION)	10	1
-	A311122	TRIM, TOP FRONT PANEL	21	1
4	A882027	LOGO W/TAPE (MAYTAG)	10	1
5	A150309	SCREW, CRIMPTITE	10	8
6	A121405	GROMMET, RUBBER	10	1

*Color Code (-)=Not Shown #=Series, Serial Prefix or Run No., N=Not Available

Section: LOWER FRONT PANEL ASSEMBLY

Model: MLG32PDAWW

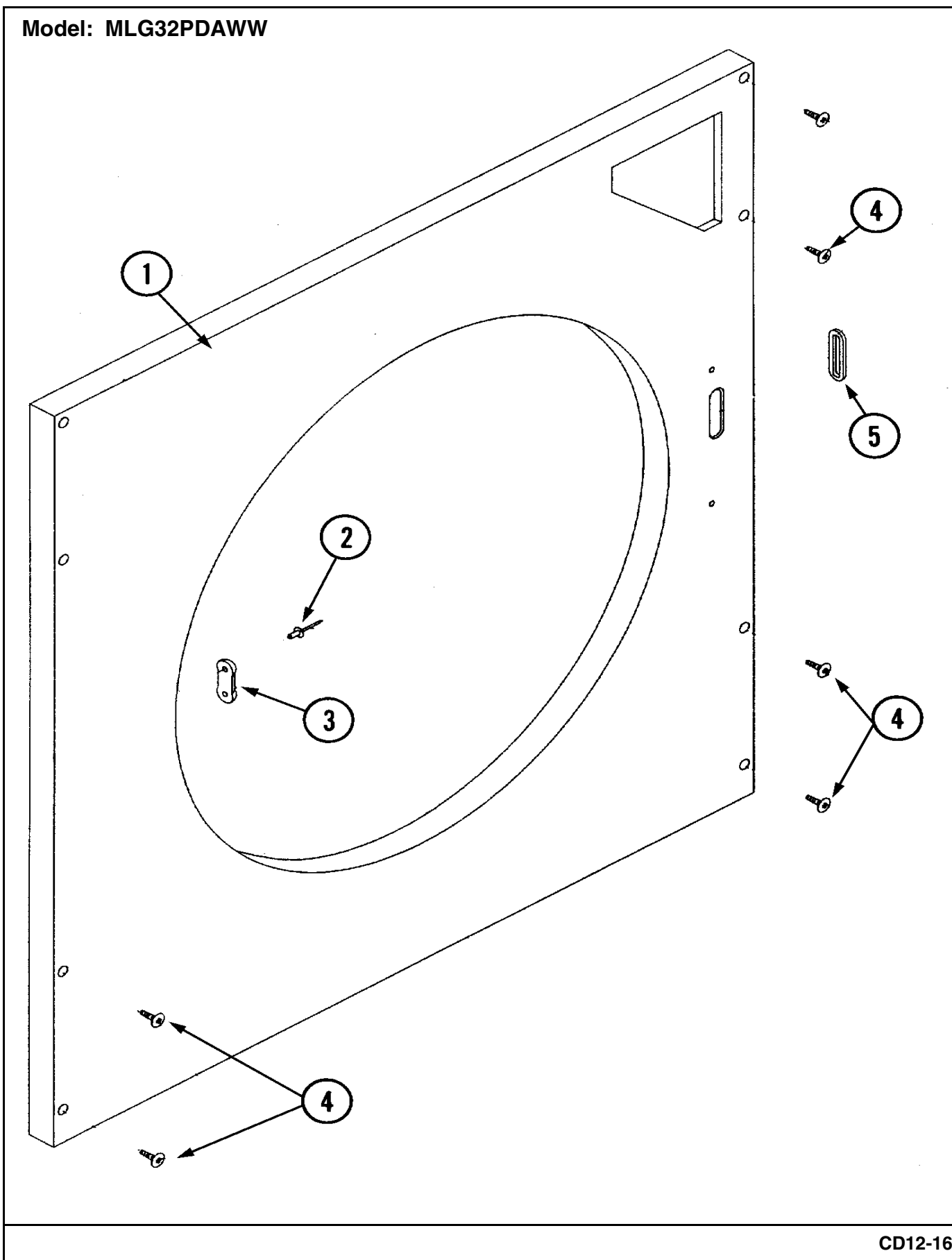

CD12-16

Section: LOWER FRONT PANEL ASSEMBLY

No.	Part No.	Description	Series	Qty
0	-----	NOT REQUIRED PART OR SEE NOTE Note: ORDER PARTS FROM AMERICAN DRYER CORP AT 508-678-9000	10	1
1	A882061	PANEL, FRONT (LWR-WHT)	10	1
2	A154215	RIVET, POP (5/32")	10	2
3	A170330	LATCH, DOOR (FRICTION)	10	1
4	A150309	SCREW, CRIMPTITE	10	9
5	A121405	GROMMET, RUBBER	10	1

*Color Code (-)=Not Shown #=Series, Serial Prefix or Run No., N=Not Available

Section: COIN VAULT ASSEMBLY

Model: MLG32PDAWW

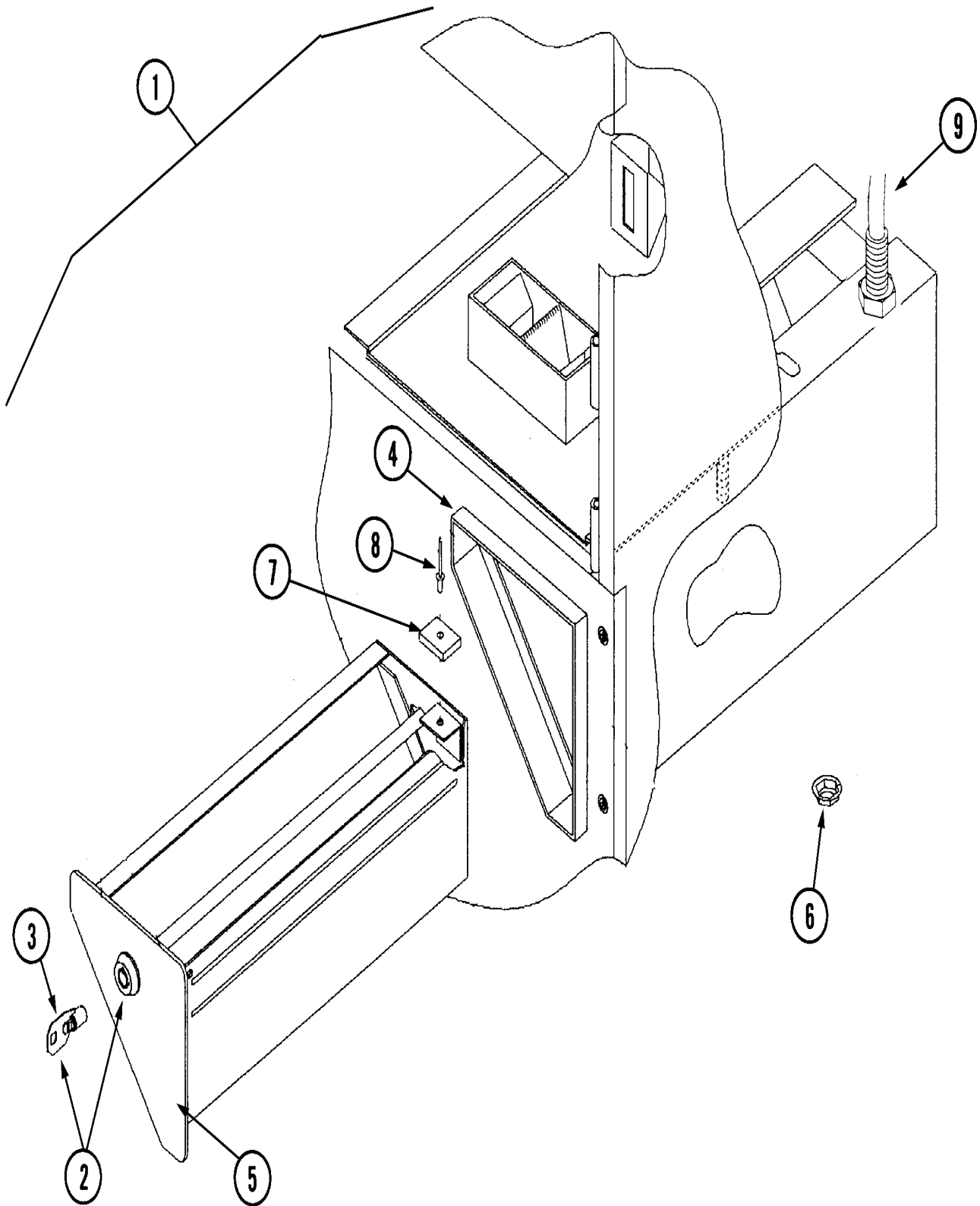

CD21-64

Section: COIN VAULT ASSEMBLY

No.	Part No.	Description	Series	Qty
0	-----	NOT REQUIRED PART OR SEE NOTE Note: ORDER PARTS FROM AMERICAN DRYER CORP AT 508-678-9000		1
1	A881981	COIN BOX ASSY. (WHT) Note: (PRIOR SER.#828113UH)		1
1	A882063	COIN BOX ASSY. (WHT) Note: (SER.#828113UH & AFTER)		1
2	A160036	LOCK ASSY. W/KEY		1
3	A160136	KEY		1
4	A801519	Coin box W/INSERT		1
4	A881975	COIN VAULT (WHT)		1
5	A882028	FACEPLATE (WHT)		1
6	A152014	NUT, FREE SPIN WASH (#20-1/4)		4
7	A102102	MAGNETIC, MAIN DOOR Note: MAGNET (SER.#828113UH & AFTER - WHT) (SER.#827957UF & AFTER - ALM)		1
7	N 102103	MAGNET Note: (PRIOR SER.#828113UH - WHT) (PRIOR SER.#827957UF - ALM)		1
8	A154215	RIVET, POP (5/32")		1
9	A884807	SWITCH, SENSOR		1

*Color Code (-)=Not Shown #=Series, Serial Prefix or Run No., N=Not Available

Section: LINT DOOR ASSEMBLY

Model: MLG32PDAWW

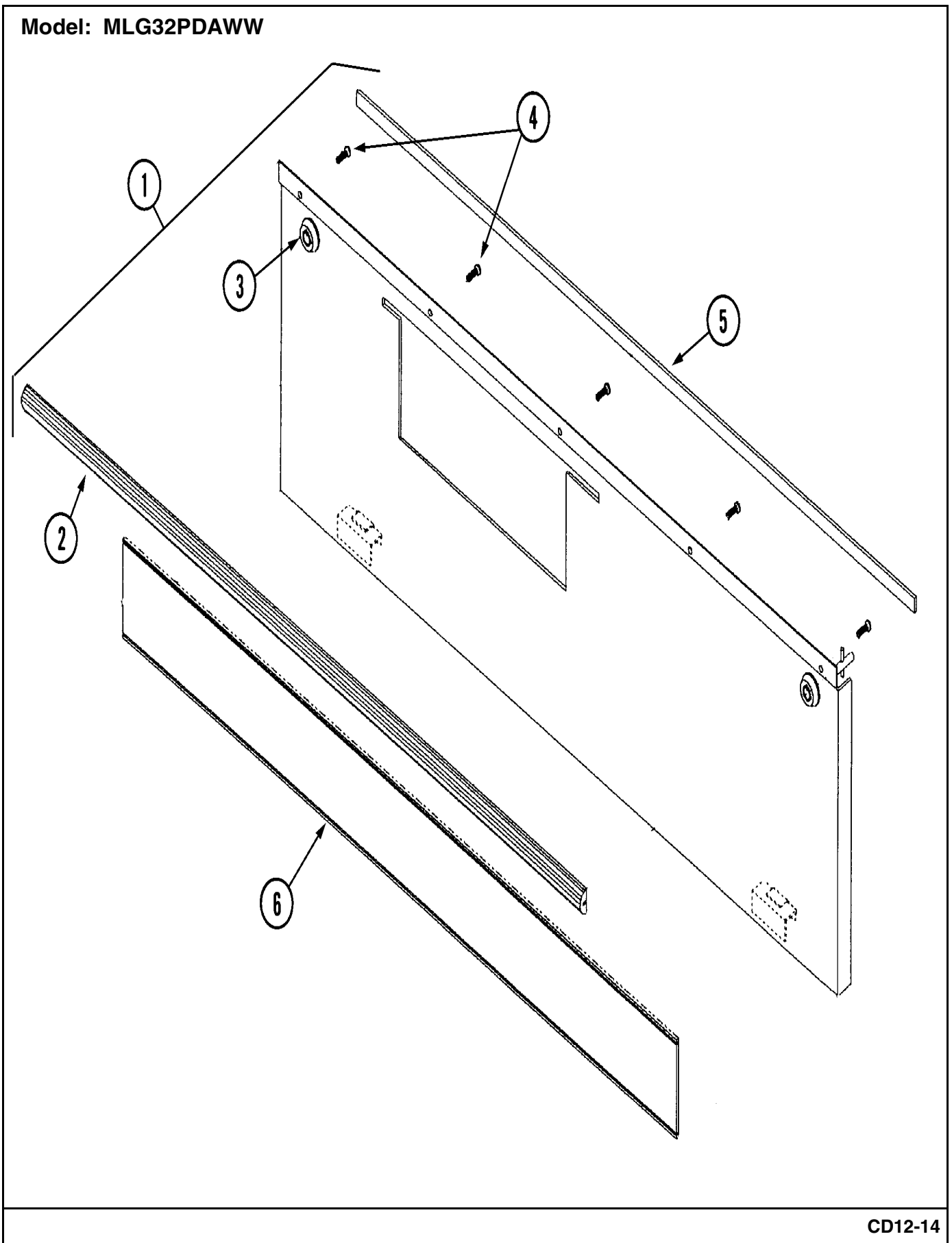

CD12-14

Section: LINT DOOR ASSEMBLY

No.	Part No.	Description	Series	Qty
0	-----	NOT REQUIRED PART OR SEE NOTE Note: ORDER PARTS FROM AMERICAN DRYER CORP AT 508-678-9000		1
1	A881983	LINT DOOR ASSY. (WHT) Note: (LOCK/KEYS NOT INCLUDED)		1
-	A850781	FRONT PANEL, BOTTOM		1
2	A180224	TRIM, TOP (CONTROL DOOR)		1
3	A160040	LOCK ASSY.		2
-	A160140	KEY ONLY, HI SEC LOCK (XX4451)		2
4	A150201	SCREW, MACHINE (#10-32 X 1/4") Note: SCREW, PH (#10-32 X 1/4")		5
5	A117602	TAPE, NOISE SUPPRESSOR		3
6	A180229	TRIM, KICK (BLK)		1

*Color Code (-)=Not Shown #=Series, Serial Prefix or Run No., N=Not Available

Section: LINT DRAWER ASSEMBLY

Model: MLG32PDAWW

A)

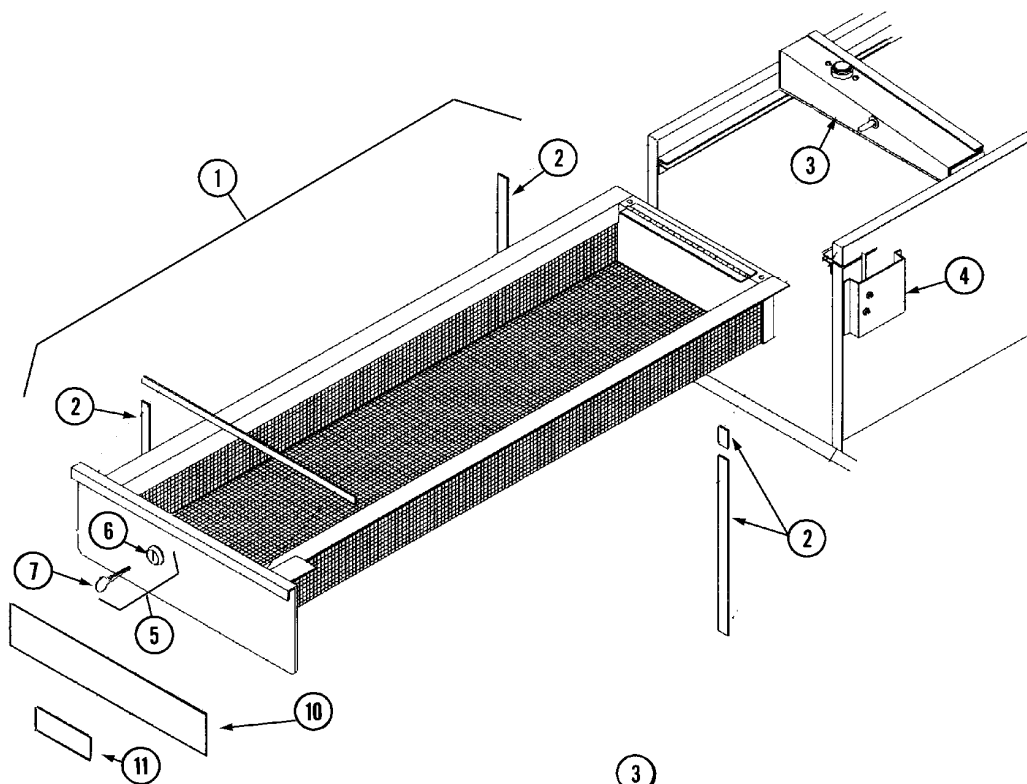

B)

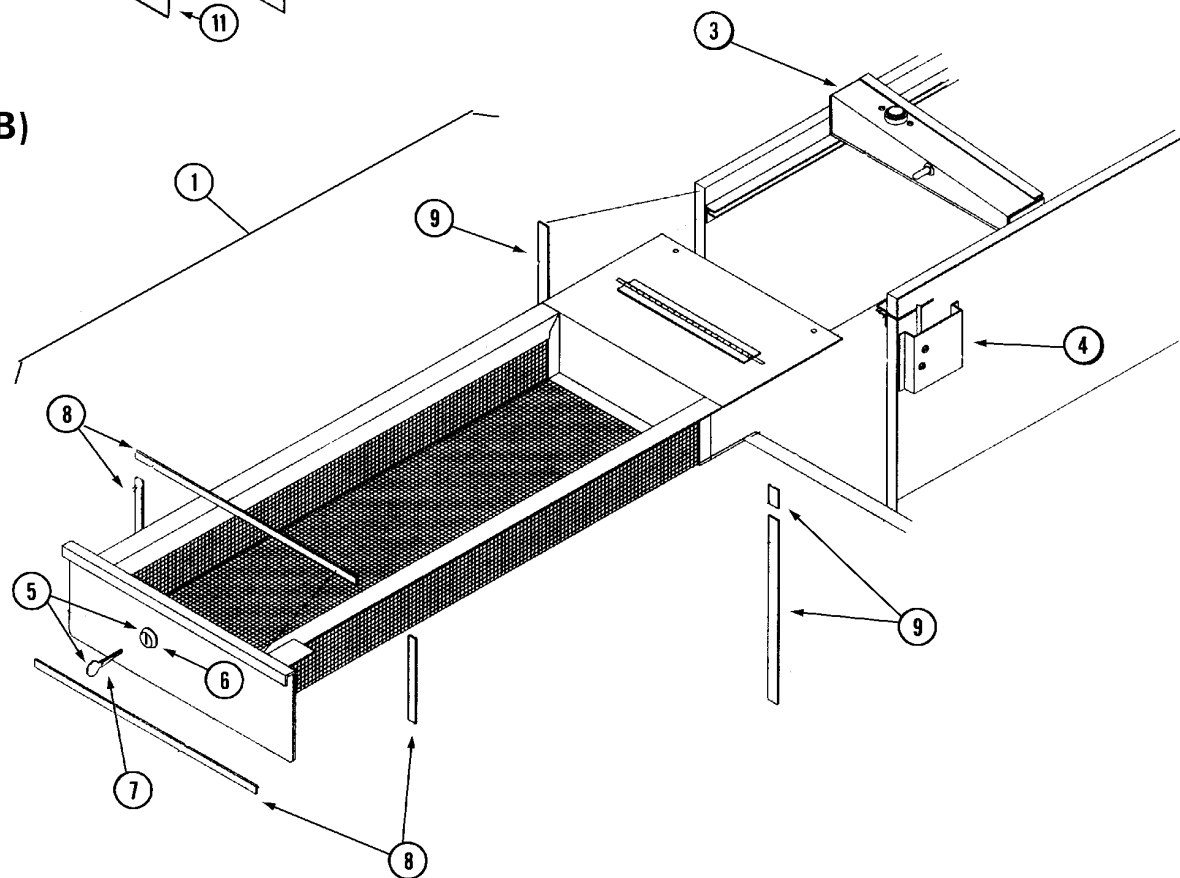

CD21-72

Section: LINT DRAWER ASSEMBLY

No.	Part No.	Description	Series	Qty
0	-----	NOT REQUIRED PART OR SEE NOTE Note: ORDER PARTS FROM AMERICAN DRYER CORP. AT 508-678-9000	10	1
1	A881983	LINT DOOR ASSY. (WHT) Note: A) LINT DRWR ASSY. (WHT)	10	1
1	A882087	B) LINT DOOR ASSY. (WHT) Note: B) LINT DRWR ASSY. (WHT)	10	1
-	A815842	LINT BASKET WELDMENT ASSY	21	1
2	A117600	GASKET, TAPE (SOLD IN FEET)	10	1
3	A311505	BRACKET, TEMP. SENSOR	10	1
4	A304039	BRACKET/COVER	10	1
5	A160039	LOCK, LINT DOOR (XX4451) Note: LOCK ASSEMBLY (XX4451)	10	1
6	A160034	CAM	10	1
7	A160140	KEY ONLY, HI SEC LOCK (XX4451) Note: KEY (XX4451)	10	1
8	A117604	TAPE, FOAM (SOLD IN FEET)	10	4
9	A117605	GASKET	10	4
10	A114074	LABEL (OPERATING INSTRUCTIONS)	10	1
11	A112280	LABEL (CLEAN LINT SCREEN)	10	1

*Color Code (-)=Not Shown #=Series, Serial Prefix or Run No., N=Not Available

Section: TEMP. SENSOR BRKT. ASSEMBLY (MLG32PDAW*)

Model: MLG32PDAWW

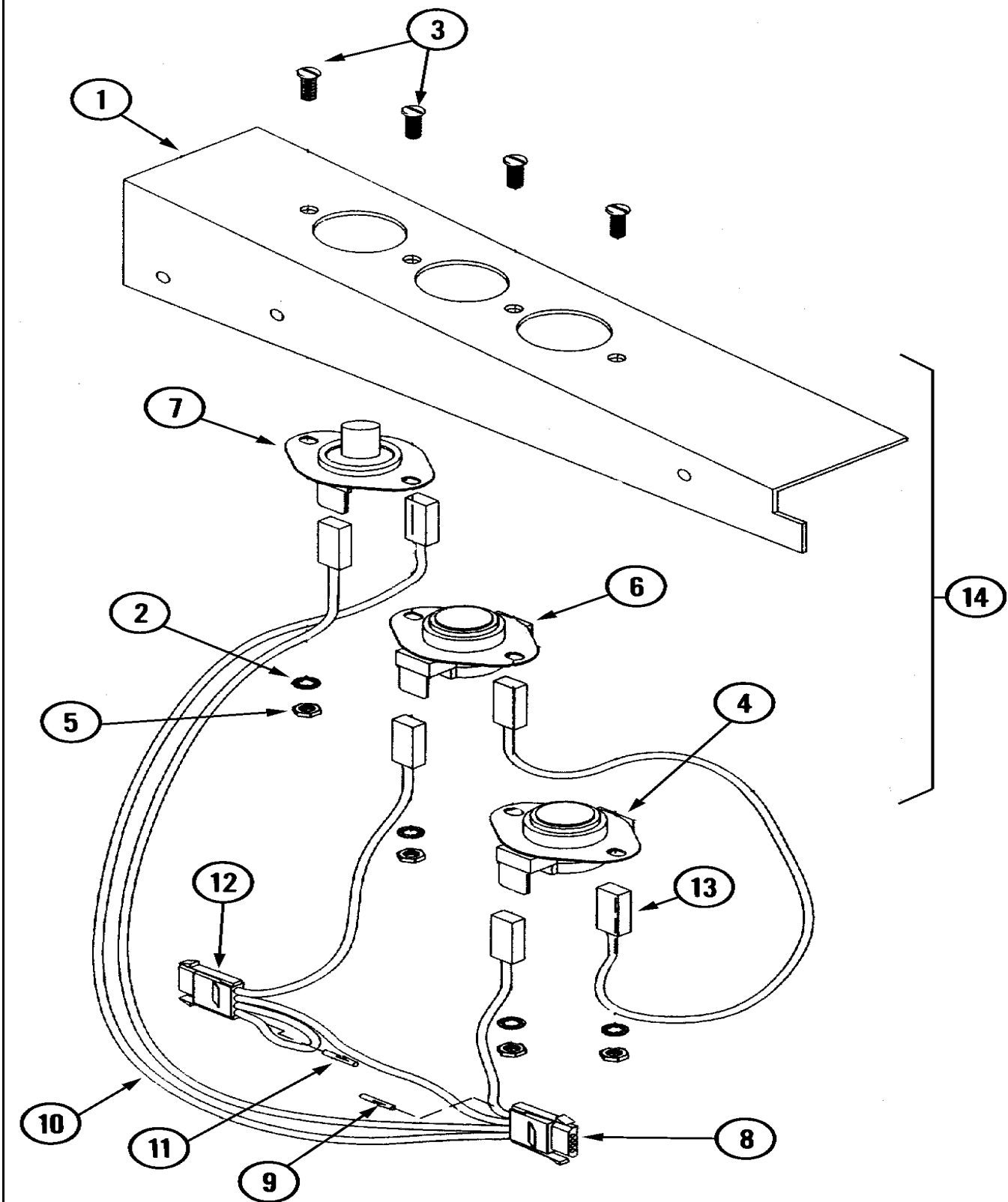

Section: TEMP. SENSOR BRKT. ASSEMBLY (MLG32P)

No.	Part No.	Description	Series	Qty
0	-----	NOT REQUIRED PART OR SEE NOTE Note: ORDER PARTS FROM AMERICAN DRYER CORP AT 508-678-9000		1
1	A311505	BRACKET, TEMP. SENSOR		1
2	A153010	WASHER, STAR (#6) Note: WASHER, STAR (#6)		4
3	A150005	SCREW, PHILL (6-32 X 1/4")RND Note: SCREW, RND HD (#6-32 X 1/4")		4
4	A130111	THERMOSTAT (170 DEGREE)		1
5	A152000	NUT, HEX (#6-32) Note: NUT (#6-32)		4
6	A130116	THERMOSTAT (140 DEGREE)		1
7	A130115	THERMISTOR		1
8	A122604	CONNECTOR (4 PIN) Note: CONNECTOR (4 PIN)		4
9	A122700	TERMINAL, PIN Note: TERMINAL, PIN (MALE)		4
10	A821987	HARNESS, SENSOR BRKT. (TOP)		1
10	A821988	HARNESS, SENSOR BRKT. (BOTTOM)		1
11	A122700	TERMINAL, PIN Note: TERMINAL, PIN (MALE)		4
12	A122604	CONNECTOR (4 PIN)		4
13	A122636	TERMINAL, FLAG (INSULATED) Note: TERMINAL, FLAG (INSULATED)		4
14	A881970	TEMP. SENSOR ASSY. Note: TEMP. SENSOR ASSY. (INCLS ITEMS 1 THRU 7 W/150 & 130 DEGREE T-STATS)		1
14	A882107	TEMP. SENSOR ASSY. Note: TEMP. SENSOR ASSY. (INCLS ITEMS 1 THRU 7 W/160 & 140 DEGREE T-STATS)		1

*Color Code (-)=Not Shown #=Series, Serial Prefix or Run No., N=Not Available

Section: LINT DRAWER SWITCH ASSEMBLY (MLG32PDAW*)

Model: MLG32PDAWW

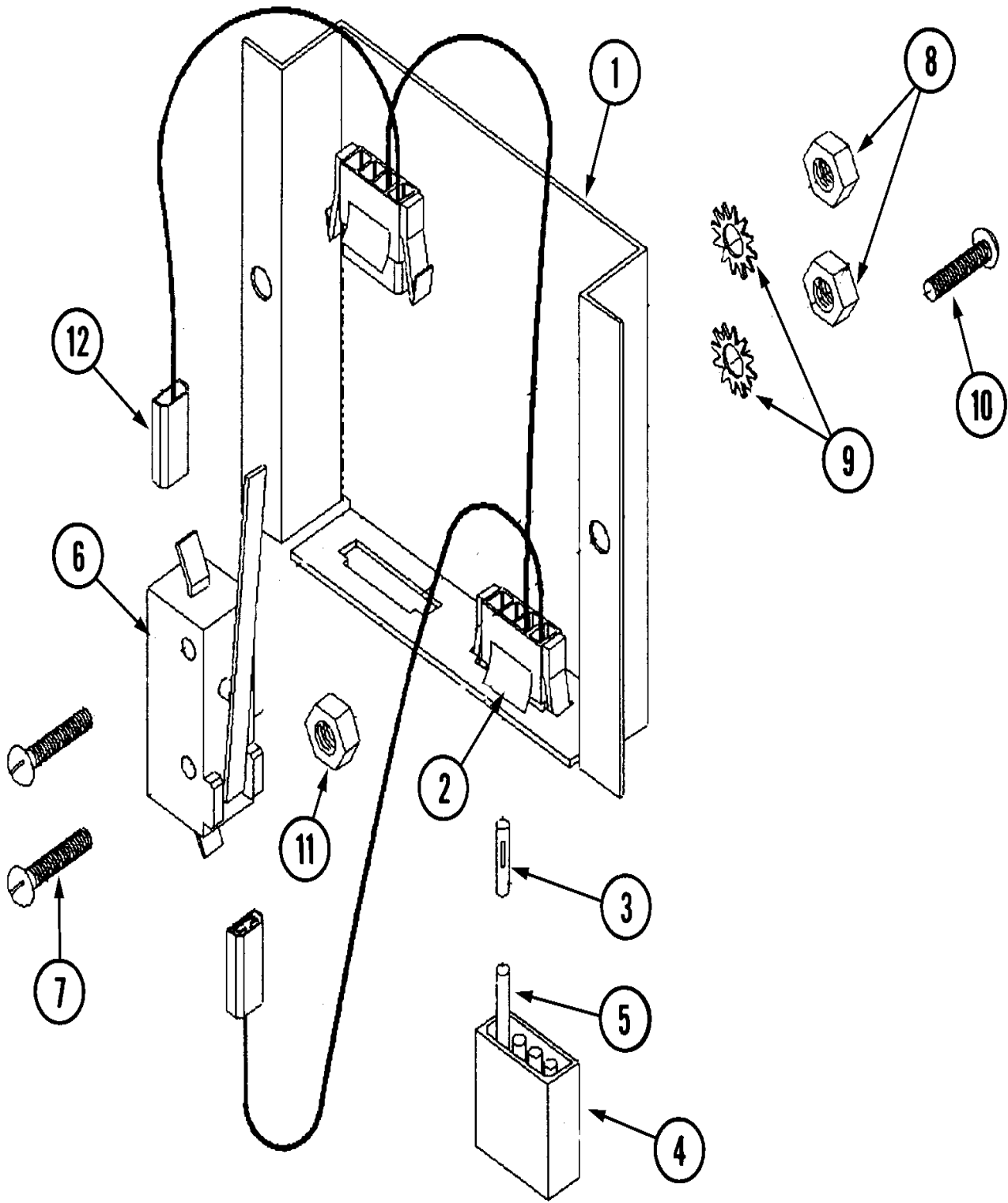

Section: LINT DRAWER SWITCH ASSEMBLY (MLG32)

No.	Part No.	Description	Series	Qty
0	-----	NOT REQUIRED PART OR SEE NOTE Note: ORDER PARTS FROM AMERICAN DRYER CORP. AT 508-678-9000	10	1
1	A304039	BRACKET/COVER	10	1
2	A122605	CONNECTOR, 4-PIN SOCKET Note: CONNECTOR, SOCKET (4 PIN)	10	2
3	A122701	TERMINAL, SOCKET (ONLY) Note: TERMINAL, SOCKET	10	8
4	A122604	CONNECTOR (4 PIN) Note: CONNECTOR (4 PIN)	10	2
5	A122700	TERMINAL, PIN Note: PIN, TERMINAL	10	8
6	A136992	SWITCH, LINT DRAWER (ONLY)	10	1
7	A150002	SCREW, MACHINE (RD.HD.) Note: SCREW, RND HEAD (#6-32 X 1")	10	2
8	A152000	NUT, HEX (#6-32) Note: NUT (#6-32)	10	2
9	A153010	WASHER, STAR (#6) Note: WASHER, STAR (#6)	10	2
10	A150001	SCREW, MACHINE (#6-32 X 1/2") Note: SCREW (#6-32 X 1/2")	10	2
11	A152013	NUT, HEX (#6-32) Note: NUT (#6-32)	10	2
12	A121028	TERMINAL, 1/4" INSUL. (FEMALE) Note: TERMINAL (1/4" INSULATED)	10	2

*Color Code (-)=Not Shown #=Series, Serial Prefix or Run No., N=Not Available

Section: TUMBLER AND SUPPORT ASSEMBLY

Model: MLG32PDAWW

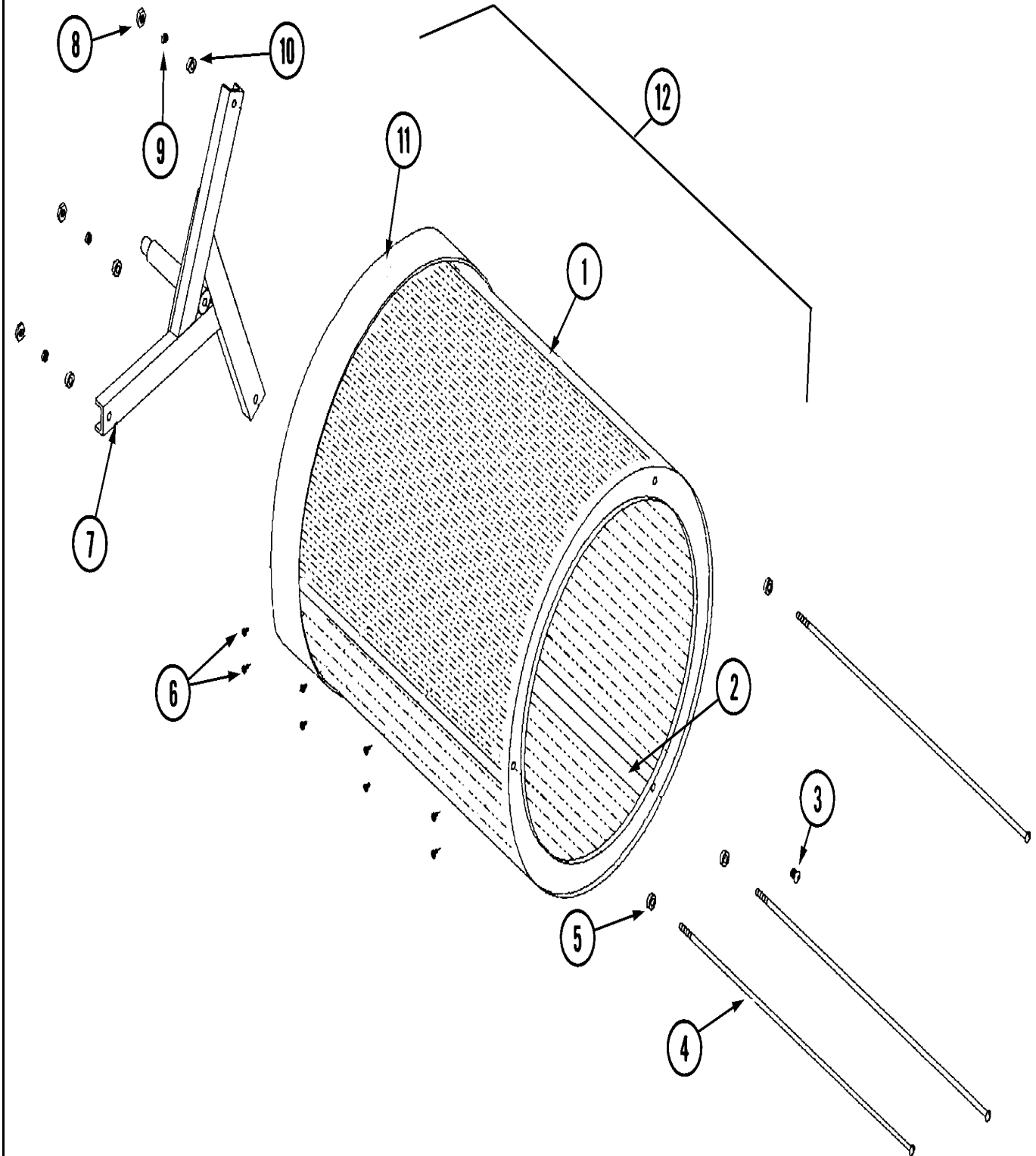

CD16-21

Section: TUMBLER AND SUPPORT ASSEMBLY

No.	Part No.	Description	Series	Qty
0	-----	NOT REQUIRED PART OR SEE NOTE Note: ORDER PARTS FROM AMERICAN DRYER CORP AT 508-678-9000		1
1	A800722	TUMBLER	10	1
2	A301315	RIB, SHORT TAPERED	10	2
2	A301316	RIB, TALL TAPERED	10	1
3	A150518	SCREW, SOCKET HEAD Note: SCREW, SOCKET HD (5/16"X3/8")	10	1
4	A882050	ROD, TIE Note: ROD, TIE (5/16"X 31")	10	3
5	A153001	WASHER, FLAT (5/16") Note: WASHER (5/16")	10	3
6	A150309	SCREW, CRIMPTITE Note: SCREW, CRIMPTITE(#10-16X1/2")	10	30
7	A850064	SUPPORT, TUMBLER	10	1
8	A152004	NUT, HEX (#18-5/16) Note: NUT (5/16"-18)	10	3
9	A153002	WASHER, LOCK (5/16") Note: WASHER, LOCK (5/16")	10	3
10	A153001	WASHER, FLAT (5/16") Note: WASHER, FLAT (5/16")	10	3
11	A116003	COLLAR, FELT	10	1
-	A401010	ADHESIVE, FELT COLLAR #847	10	1
12	A800797	TUMBLER/SUPPORT ASSY.	10	1

*Color Code (-)=Not Shown #=Series, Serial Prefix or Run No., N=Not Available

Section: TUMBLER BEARING ASSEMBLY (MLG32PDAW*)

Model: MLG32PDAWW

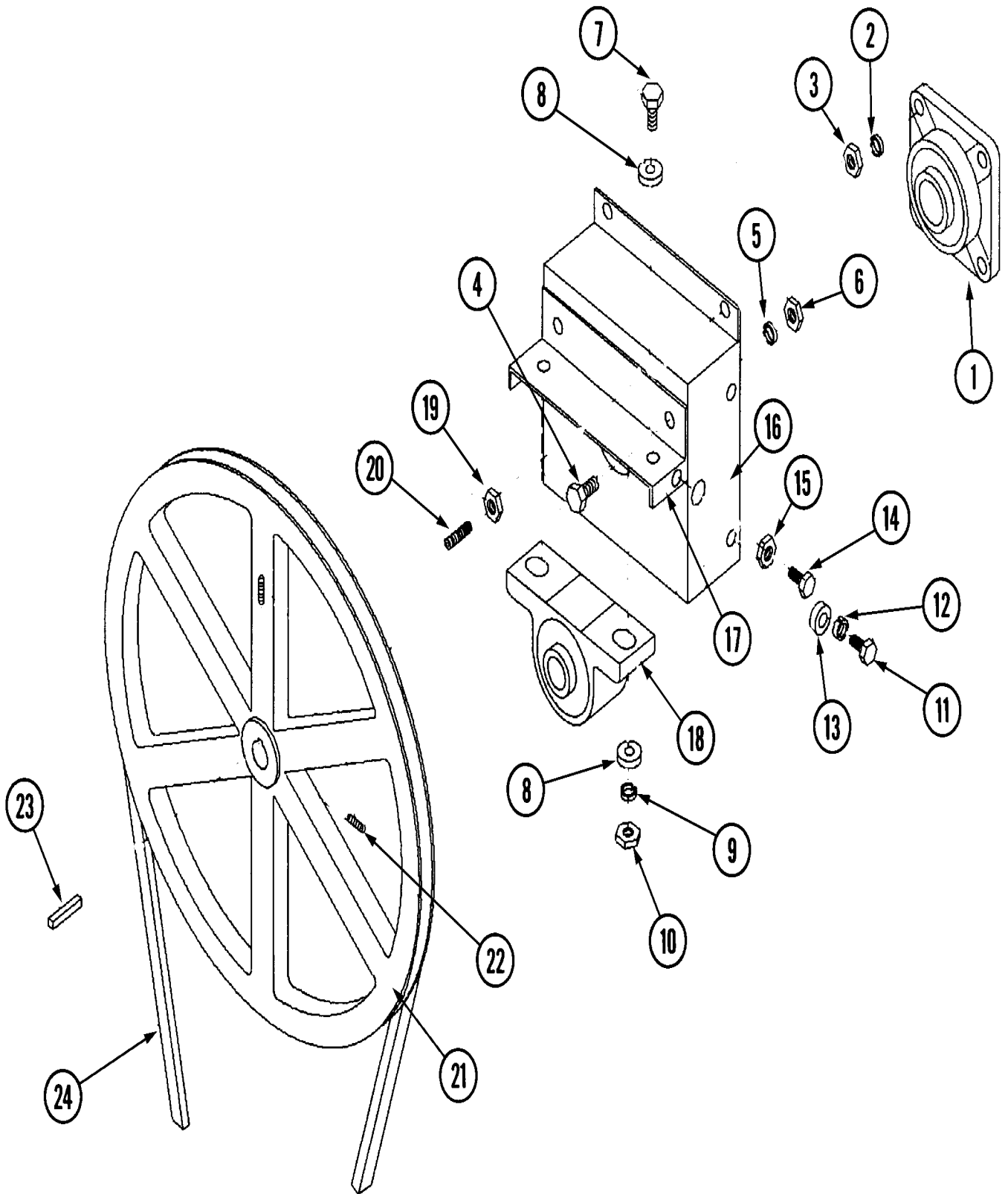

CD16-22

Section: TUMBLER BEARING ASSEMBLY (MLG32PDA)

No.	Part No.	Description	Series	Qty
0	-----	NOT REQUIRED PART OR SEE NOTE Note: ORDER PARTS FROM AMERICAN DRYER CORP AT 508-678-9000		1
1	A880203	BEARING, FLANGE W/SET SCREW		1
2	A153005	WASHER, LOCK (3/8") Note: WASHER, LOCK (3/8")		4
3	A152005	NUT, HEX (#16-3/8") Note: NUT (3/8")		4
4	A150508	BOLT, MACHINE (#16-3/8 X 3/4) Note: BOLT,HEX HD (3/8"-16 X 3/4")		2
5	A153005	WASHER, LOCK (3/8") Note: WASHER, LOCK (3/8")		2
6	A152005	NUT, HEX (#16-3/8") Note: NUT (3/8"-16)		2
7	A150600	BOLT, MACHINE (#16-3/8 X 11/2) Note: BOLT, HEX HD (3/8"-16 X 1/2")		2
8	A153004	WASHER, FLAT (3/8") Note: WASHER, FLAT (3/8")		2
9	A153005	WASHER, LOCK (3/8") Note: WASHER, LOCK (3/8")		2
10	A152005	NUT, HEX (#16-3/8") Note: NUT (3/8"-16)		2
11	A150501	BOLT, MACHINE (#18-5/16 X 3/4) Note: BOLT, HEX HD (5/16-18 X 3/4")		4
12	A153002	WASHER, LOCK (5/16") Note: WASHER, LOCK (5/16")		4
13	A153001	WASHER, FLAT (5/16") Note: WASHER, FLAT (5/16")		4
14	A150621	BOLT, MACHINE (#18-5/16X1 1/2) Note: BOLT, HEX HD(5/16-18 X 1-1/2")		2
15	A152004	NUT, HEX (#18-5/16) Note: NUT (5/16"-18)		2
16	A801105	BEARING BOX (1 3/8") Note: BEARING BOX		1
16	A801101	BEARING, BOX ASSY (1 3/8") Note: (INCL. ITEMS 4 THRU 20)		1
16	A801103	BEARING BOX & SUPPORT (1 3/8") Note: BEARING BOX & SUPPORT		1
17	A801104	SUPPORT, PILLOW BLOCK BEARING Note: SUPPORT, BEARING		1
18	A880202	BEARING, PILLOW BLOCK		1
19	A152004	NUT, HEX (#18-5/16) Note: NUT (5/16"-18)		2
20	A150610	SCREW, SET (#18-5/16" X 1 1/2) Note: SCREW (5/16"18 X 1-1/2")		2
21	A101100	PULLEY (18")		1
22	A154301	SCREW, ALLEN (#18-5/16 X 5/16) Note: SCREW, ALLEN SET (5/16"-18 X 1 1/2")		2
23	A100713	KEY (1/4" X 1/4" X 7/8")		1
24	A100100	V-BELT		1

*Color Code (-)=Not Shown #=Series, Serial Prefix or Run No., N=Not Available

Section: IDLER BEARING ASSEMBLY

Model: MLG32PDAWW

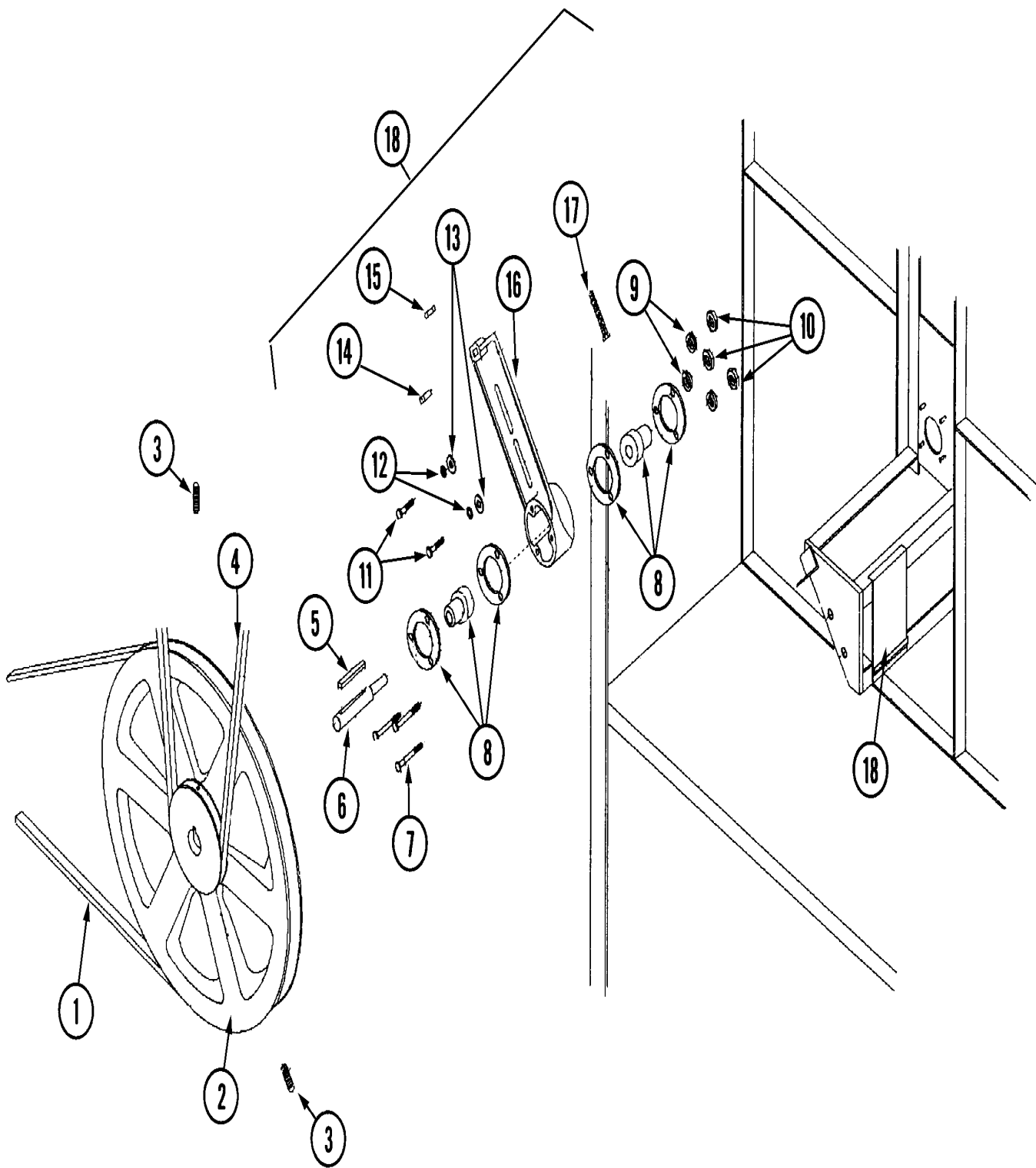

CD21-67

Section: IDLER BEARING ASSEMBLY

No.	Part No.	Description	Series	Qty
0	-----	NOT REQUIRED PART OR SEE NOTE Note: ORDER PARTS FROM AMERICAN DRYER CORP AT 508-678-9000		1
1	A100144	V-BELT Note: V-BELT (4L400)		10
2	A101129	PULLEY W/KEY(9" X 2 1/2") Note: PULLEY (9" X 1 1/2" 3/16)		10
3	A154301	SCREW, ALLEN (#18-5/16 X 5/16) Note: SCREW, SET ALLEN (5/16"-18 X 5/16")		10
4	A100100	V-BELT Note: V-BELT (51660)		10
5	A100705	KEY (3/16" X 3/16" X 1-3/8")		10
6	A301850	SHAFT, IDLER (5/8" X 3/4") Note: SHAFT, IDLER (5/8" X 3/4")		10
7	A150529	BOLT, CARRIAGE (1/4 X 2 1/4")		10
8	A880214	BEARING, FLANGE (5/8) Note: BEARING, FLANGE (5/8")		10
9	A153007	WASHER, LOCK (1/4") Note: WASHER, LOCK (1/4")		10
10	A152002	HEX NUT (#20-1/4") Note: NUT (1/4"-20)		10
11	A150617	BOLT, MACHINE (#16-3/8 X 1") Note: BOLT, HEX HD (3/8"-16 X 1")		10
12	A153005	WASHER, LOCK (3/8") Note: WASHER, LOCK (3/8")		10
13	A153004	WASHER, FLAT (3/8") Note: WASHER (3/8")		10
14	A152020	NUT, STANDARD (#18-5/16") Note: NUT, SQUARE (5/16"-18)		10
15	A152004	NUT, HEX (#18-5/16) Note: NUT (5/16-18)		10
16	A100406	BEARING, IDLER ASSEMBLY Note: BRACKET, MOUNTING		10
17	A150509	BOLT, MACHINE (5/16-18 X 3") Note: BOLT, HEX HD (5/16"-18 X 3")		10
18	N A801010	MOUNT, IDLER BEARING Note: (INCL. ITEMS 6 THRU 17)		10

*Color Code (-)=Not Shown #=Series, Serial Prefix or Run No., N=Not Available

Section: GAS VALVE ASSEMBLY (PRIOR TO YW SERIAL#)

Model: MLG32PDAWW

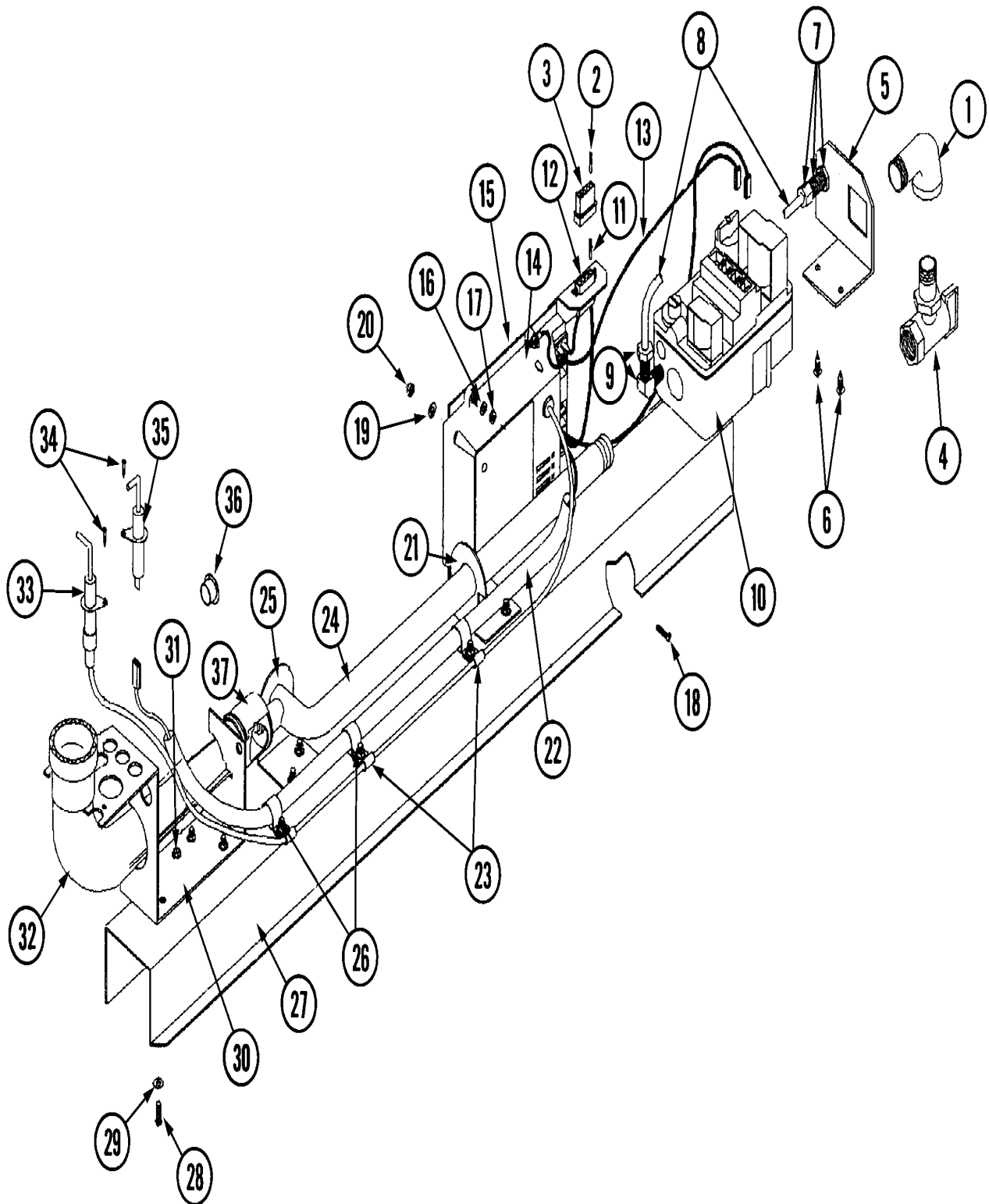

Section: GAS VALVE ASSEMBLY (PRIOR TO YW SERI

No.	Part No.	Description	Series	Qty
0	-----	NOT REQUIRED PART OR SEE NOTE Note: ORDER PARTS FROM AMERICAN DRYER CORP AT 508-678-9000		1
1	A142506	ELBOW, STREET (1/2" X 1/2") Note: ELBOW, STREET (1/2" X 1/2")	10	1
2	A122700	TERMINAL, PIN Note: TERMINAL, PIN	10	2
3	A122604	CONNECTOR (4 PIN) Note: CONNECTOR (4-PIN)	10	1
4	A881367	UNION, SHUT-OFF (1/2")	10	1
5	A318712	BRACKET, GAS VALVE PIPE	10	1
6	A150301	SCREW, TEK (#8-18 X 7/16 PH Note: SCREW (#8-18 X 7/16")	10	2
7	A143259	FITTING, BULKHEAD	10	1
8	A143100	TUBING, ALUMINUM (1/4")	10	1
9	A143203	ADAPTER, LINE (90 DEG.)	10	1
-	A140411	CONVERSION KIT, GAS VALVE	10	1
10	A128927	VALVE, REDUNDANT (1/2" 24VAC) Note: VALVE, GAS	10	1
11	A122701	TERMINAL, SOCKET (ONLY) Note: TERMINAL, SOCKET	10	2
12	A122605	CONNECTOR, 4-PIN SOCKET	10	1
13	A842716	WIRING, VALVE (TOP)	10	1
13	A842724	WIRING, VALVE (BOTTOM)	10	1
14	A880815	MODULE, DSI	10	1
15	A850808	BRACKET, MOUNTING (DSI MODULE)	10	1
16	A153017	WASHER (#6 STAR)	10	4
17	A151000	PAL NUT (#6-32)	10	4
18	A153528	STUD, SELF CLINCHING Note: STUD (#8-32 X 1/2")	10	2
19	A153012	WASHER, STAR (#8)	10	2
20	A152001	NUT, HEX (#8-32)	10	2
21	A318711	BRACKET, NOTCHED PIPE	10	1
22	A121060	FLEXTITE, CLEAR (5/8")	10	4
23	A121492	CLAMP, NYLON (3/16")	10	3
24	A141225	MANIFOLD, SINGLE PORT	10	1
25	A318700	BRACKET, PIPE (BENT)	10	1
26	A121491	CLAMP (5/8")	10	3
27	A319522	VALVE, GAS TRAIN ASSEMBLY	10	1
28	A153528	STUD, SELF CLINCHING Note: STUD (#8-32 X 1/2")	10	9
29	A153012	WASHER, STAR (#8)	10	16
30	A318009	BRACKET, BURNER TUBE (PSE)	10	1
31	A151001	NUT, PAL (#8-32)	10	8
-	A307122	V-BRACKET	24	1
32	A141130	TUBE, BURNER W/SHUTTER	10	1
33	A128917	IGNITER W/LEAD	10	1
34	A150315	SCREW (#6 X 3/8" PH HD)	10	2
35	A128918	SENSOR, FLAME	10	1
36	A121300	BUSHING, OPEN/CLOSED	10	2
37	A140810	ORIFICE, BURNER (LP #42)	10	1
37	A140856	ORIFICE, BURNER (NAT #23)	10	1
37	A881936	CONVERSION KIT (LP)	10	1

*Color Code (-)=Not Shown #=Series, Serial Prefix or Run No., N=Not Available

Section: MOTOR AND MOUNT ASSEMBLY

Model: MLG32PDAWW

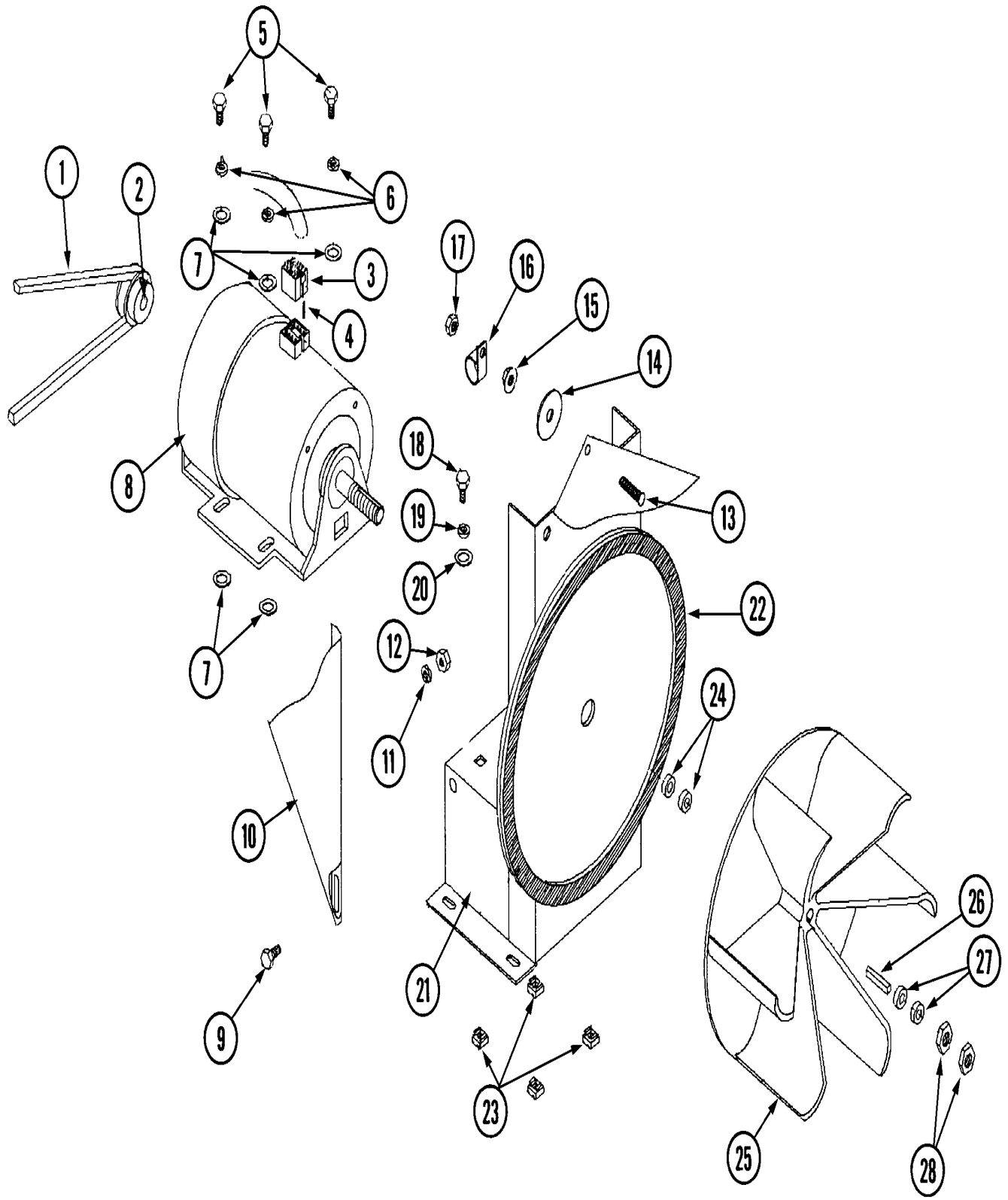

CD17-20

Section: MOTOR AND MOUNT ASSEMBLY

No.	Part No.	Description	Series	Qty
0	-----	NOT REQUIRED PART OR SEE NOTE Note: ORDER PARTS FROM AMERICAN DRYER CORP AT 508-678-9000		1
1	A100144	V-BELT		1
2	A101131	PULLEY, MOTOR (60HZ)		1
3	A137030	HOUSING (8 PIN) Note: CONNECTOR, HOUSING (8-PIN)		1
4	A122801	TOOL, EXTRACTION (PIN/SOCKET)		1
4	A122701	TERMINAL, SOCKET (ONLY) Note: TERMINAL, SOCKET		8
5	A150501	BOLT, MACHINE (#18-5/16 X 3/4)		8
6	A153002	WASHER, LOCK (5/16")		4
7	A153001	WASHER, FLAT (5/16")		8
8	A100065	MOTOR W/PLUG		1
9	A150111	SCREW, MACHINE (#20-1/4 X 1/2)		1
10	A311403	BRACKET, IDLER SUPPORT		1
11	A153007	WASHER, LOCK (1/4")		1
12	A152002	HEX NUT (#20-1/4")		1
13	A153525	STUD, SELF CLINCHING Note: STUD (1/4" X 1")		1
14	A153005	WASHER, LOCK (3/8")		1
15	A152014	NUT, FREE SPIN WASH (#20-1/4)		1
16	A121490	CLAMP, NYLON (1/2")		1
17	A152002	HEX NUT (#20-1/4") Note: NUT (1/4-20)		1
18	A150501	BOLT, MACHINE (#18-5/16 X 3/4) Note: BOLT (5/16-18 X 3/4")		4
19	A153002	WASHER, LOCK (5/16")		4
20	A153001	WASHER, FLAT (5/16")		4
21	A850019	MOTOR MOUNT ASSY. Note: SUPPORT, MOTOR MOUNTING		1
22	A117600	GASKET, TAPE (SOLD IN FEET)		4
23	A154000	NUT (#18-5/16")		4
24	A153050	WASHER, FLAT (1/2") Note: FLAT WASHER (1/2")		2
25	A100604	IMPELLOR (12 1/2" W/ 1/2 BORE) Note: IMPELLER		1
26	A100702	KEY (1/8" X 1/8" X 1 1/2")		1
27	A153050	WASHER, FLAT (1/2") Note: FLAT WASHER (1/2")		2
28	A152006	NUT, JAM (#20-1/2" LT-HAND)		2

*Color Code (-)=Not Shown #=Series, Serial Prefix or Run No., N=Not Available

Section: BURNER BOX/PIPING ASSEMBLY

Model: MLG32PDAWW

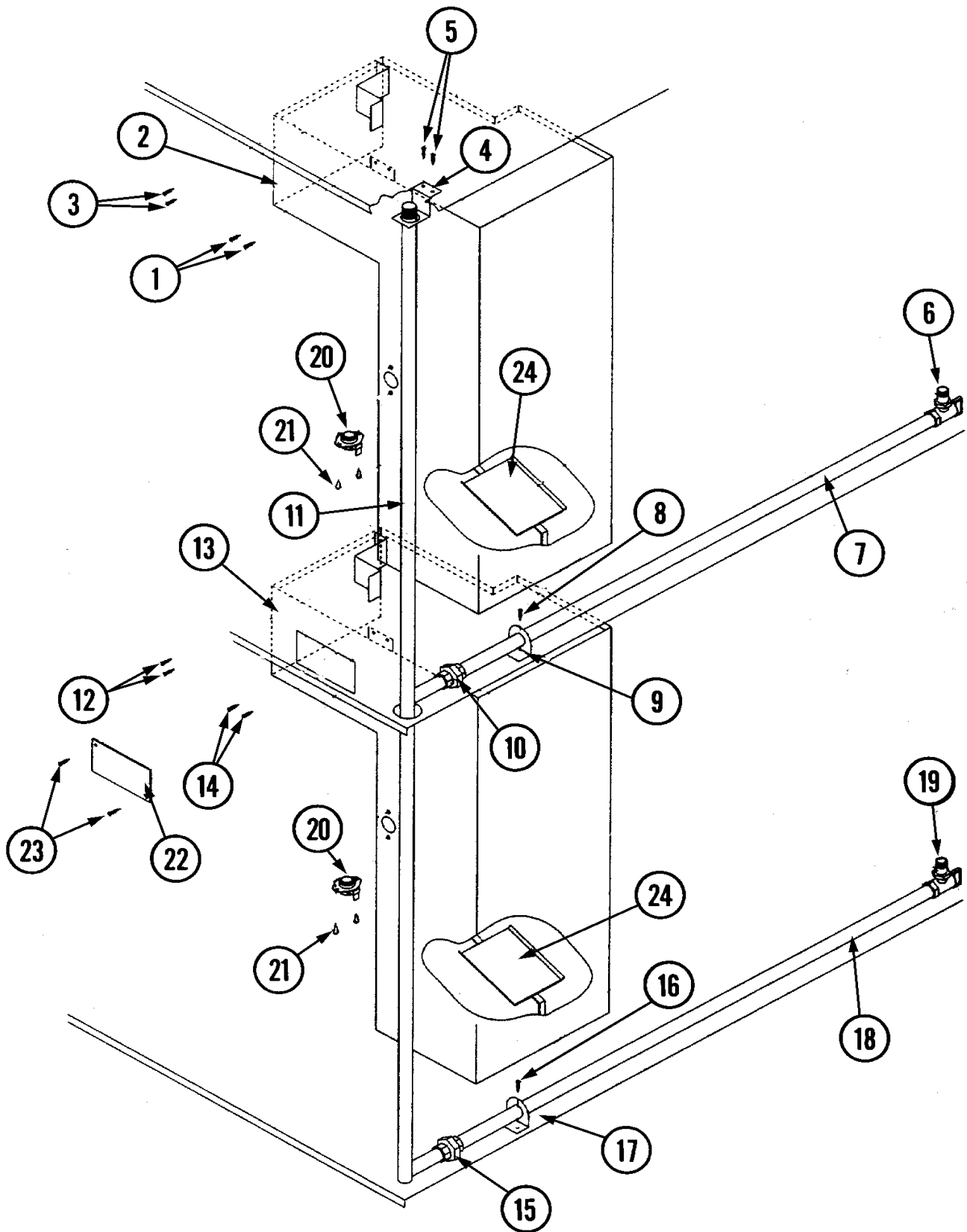

Section: BURNER BOX/PIPING ASSEMBLY

No.	Part No.	Description	Series	Qty
0	-----	NOT REQUIRED PART OR SEE NOTE Note: ORDER PARTS FROM AMERICAN DRYER CORP AT 508-678-9000		1
1	A150301	SCREW, TEK (#8-18 X 7/16 PH Note: SCREW (#8-18 X 7/16"))	10	2
2	A880121	BURNER BOX W/SPREADER ASSY.	10	1
3	A150301	SCREW, TEK (#8-18 X 7/16 PH Note: SCREW (#8-18 X 7/16"))	10	2
4	A318702	BRACKET, TOP PIPE SUPPORT	10	1
5	A150300	SCREW (#10-32 X 1/2" PH ROUND Note: SCREW (HEX HD #10 X 1/2"))	10	2
6	A881367	UNION, SHUT-OFF (1/2")	10	1
7	A142823	PIPE (1/2" X 40")	10	2
8	A150300	SCREW (#10-32 X 1/2" PH ROUND Note: SCREW (HEX HD #10 X 1/2"))	10	2
9	A318700	BRACKET, PIPE (BENT) Note: PIPE BRACKET	10	1
10	A142600	UNION (1/2")	10	1
11	A141237	MANIFOLD, INLET	10	1
12	A150301	SCREW, TEK (#8-18 X 7/16 PH Note: SCREW (#8-18 X 7/16"))	10	2
13	A880121	BURNER BOX W/SPREADER ASSY.	10	1
14	A150301	SCREW, TEK (#8-18 X 7/16 PH Note: SCREW (#8-18 X 7/16"))	10	2
15	A142600	UNION (1/2")	10	1
16	A150300	SCREW (#10-32 X 1/2" PH ROUND Note: SCREW (HEX HD #10-32 X 1/2"))	10	2
17	A318700	BRACKET, PIPE (BENT)	10	1
18	A142823	PIPE (1/2" X 40")	10	1
19	A881367	UNION, SHUT-OFF (1/2")	10	1
20	A130403	THERMOSTAT (330 DEGREE) Note: THERMOSTAT (330 DEGREE)	10	2
21	A150300	SCREW (#10-32 X 1/2" PH ROUND Note: SCREW (HEX HD #10-32 X 1/2"))	10	4
22	A318065	COVER, BURNER BOX	10	1
23	A150300	SCREW (#10-32 X 1/2" PH ROUND Note: SCREW (HEX HD #10-32 X 1/2"))	10	4
24	A850912	SPREADER ASSY.	10	1
-	A130107	THERMOSTAT, LARGE (160 DEG.)		2

*Color Code (-)=Not Shown #=Series, Serial Prefix or Run No., N=Not Available

Section: SAIL SWITCH ASSEMBLY

Model: MLG32PDAWW

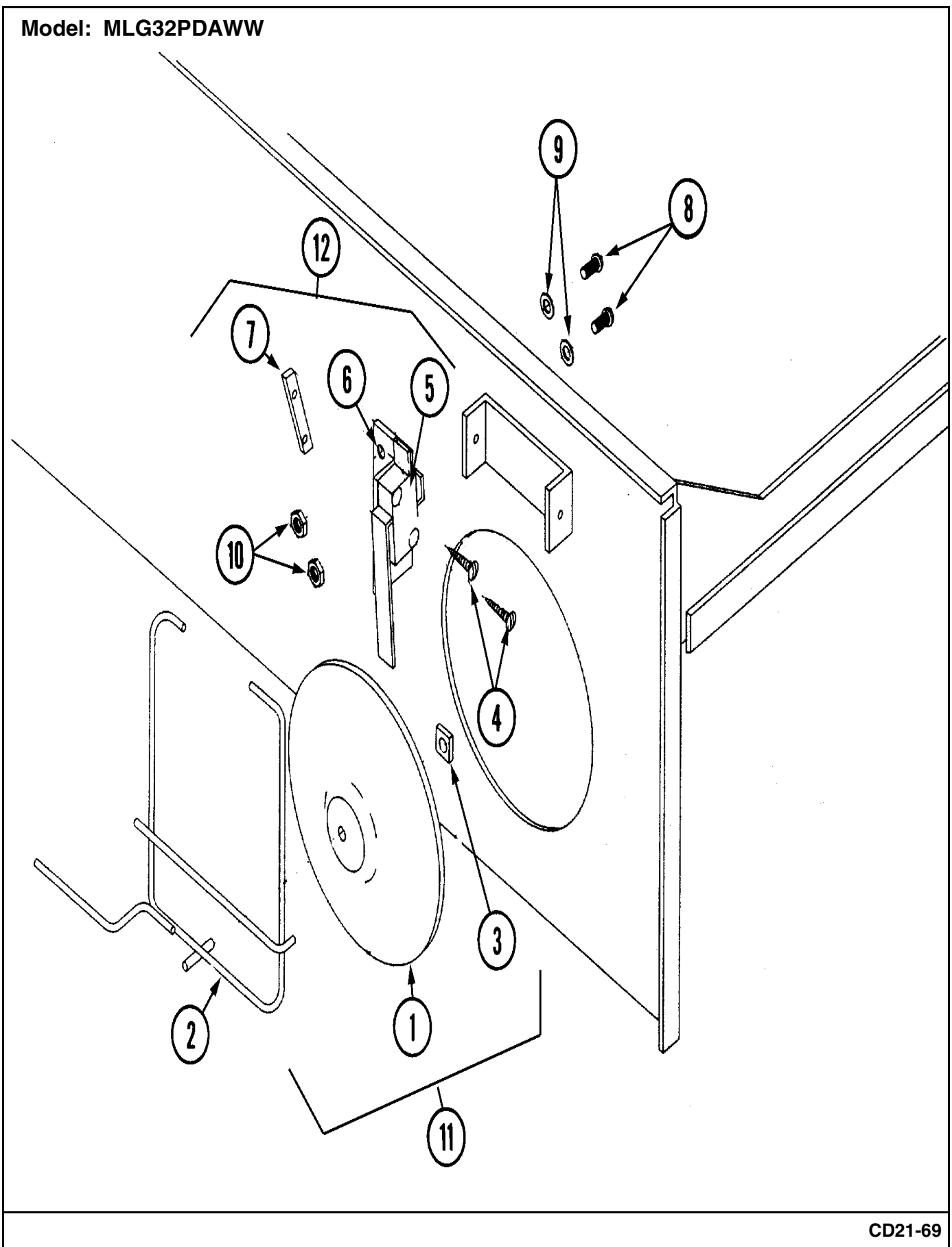

CD21-69

Section: SAIL SWITCH ASSEMBLY

No.	Part No.	Description	Series	Qty
0	-----	NOT REQUIRED PART OR SEE NOTE Note: ORDER PARTS FROM AMERICAN DRYER CORP AT 508-678-9000		1
1	A319206	DAMPER, SAIL SWITCH		1
2	A105550	ROD, SAIL SWITCH		1
3	A154002	FASTENER, PUSH-ON (1/8")		1
4	A150303	SCREW (#4 X 3/4")		2
5	A802807	SAIL SWITCH BRACKET ASSY. Note: (INCL. ITEMS 4 THRU 7)		1
5	A122200	SWITCH, SAIL		1
6	A319208	BRACKET, SAIL SWITCH		1
7	A154004	NUT, TWIN SPEED Note: SPEED NUT, TWIN		1
8	A150001	SCREW, MACHINE (#6-32 X 1/2") Note: SCREW (#6-32 X 1/2")		2
9	A153010	WASHER, STAR (#6)		2
10	A152000	NUT, HEX (#6-32) Note: NUT (#6-32)		2
11	A802805	SAIL SWITCH ROD & DAMPER ASSY. Note: (INCL. ITEMS 1 THRU 3)		1

*Color Code (-)=Not Shown #=Series, Serial Prefix or Run No., N=Not Available

Section: EXHAUST DUCTING ASSEMBLY

Model: MLG32PDAWW

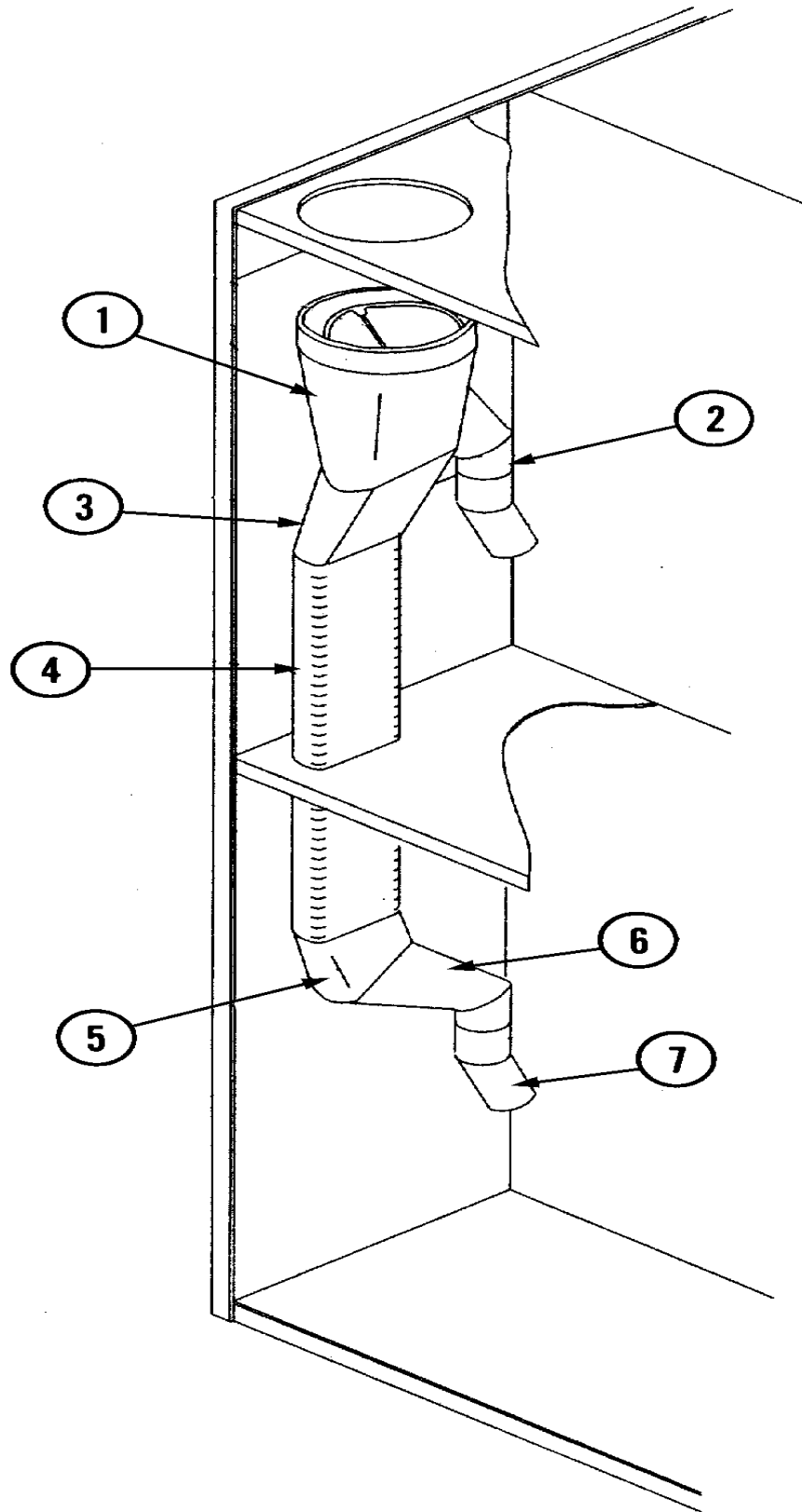

Section: EXHAUST DUCTING ASSEMBLY

No.	Part No.	Description	Series	Qty
0	-----	NOT REQUIRED PART OR SEE NOTE Note: ORDER PARTS FROM AMERICAN DRYER CORP AT 508-678-9000	10	1
1	A143535	WYE BRANCH	10	1
2	A143536	ELBOW (6" ROUND X 45 DEG.)	10	2
3	A145327	BOOT, STRAIGHT (6" RD X 7" OV)	10	1
4	A145539	DUCT (15 1/2")	10	1
5	A143537	ELBOW (7" OVAL X 45 DEG.)	10	1
6	A143538	BOOT, STRAIGHT (6" RD X 7 OV)	10	1
7	A143536	ELBOW (6" ROUND X 45 DEG.)	10	2
-	A117505	TAPE, ALUMINUM DUCT	10	6

*Color Code (-)=Not Shown #=Series, Serial Prefix or Run No., N=Not Available

Section: BACKGUARD ASSEMBLY

Model: MLG32PDAWW

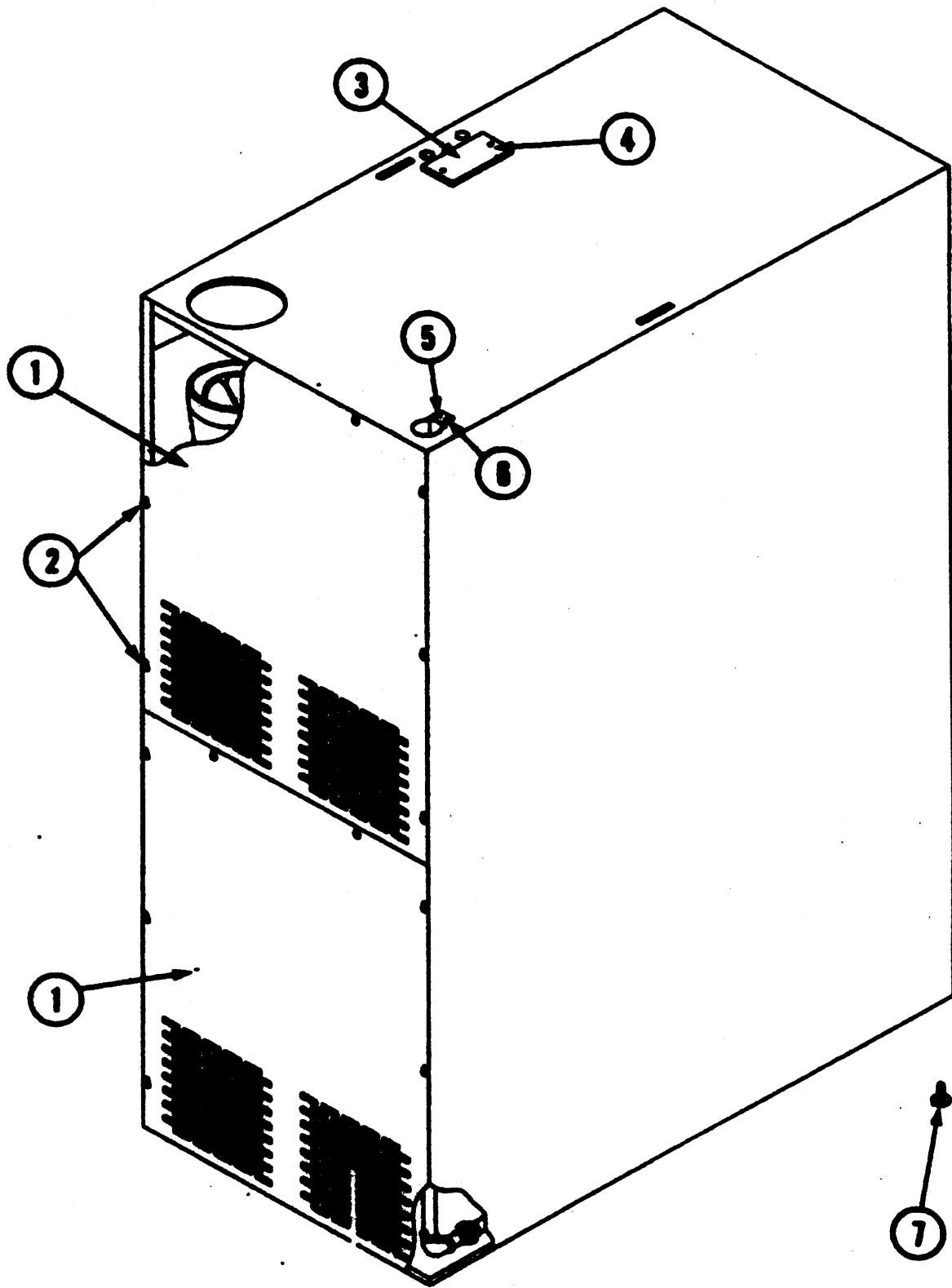

MA303F13

Section: BACKGUARD ASSEMBLY

No.	Part No.	Description	Series	Qty
0	-----	NOT REQUIRED PART OR SEE NOTE Note: ORDER PARTS FROM AMERICAN DRYER CORP AT 508-678-9000		1
1	N A311541	PANEL, BACK		2
2	A150301	SCREW, TEK (#8-18 X 7/16 PH Note: SCREW (#8-18 X 7/16"))		16
3	A315014	PLATE, COVER (TOP ELEC. BOX)		1
4	A150301	SCREW, TEK (#8-18 X 7/16 PH Note: SCREW (#8-18 X 7/16"))		2
5	A318702	BRACKET, TOP PIPE SUPPORT		1
6	A150300	SCREW (#10-32 X 1/2" PH ROUND)		2
7	A103500	LEG, LEVELING (ADJUSTABLE)		4

*Color Code (-)=Not Shown #=Series, Serial Prefix or Run No., N=Not Available

Section: DOOR SWITCH ASSEMBLY

Model: MLG32PDAWW

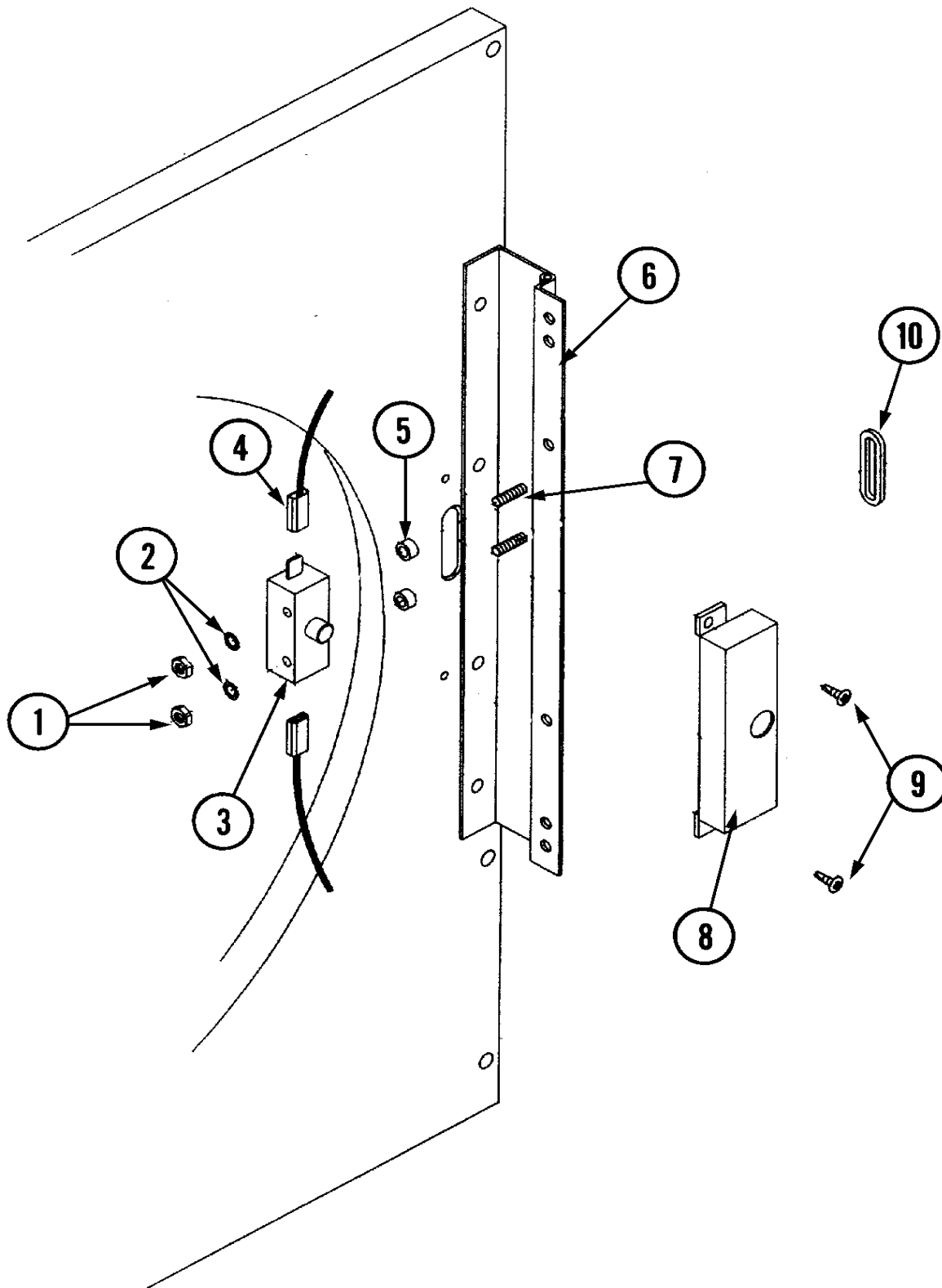

Section: DOOR SWITCH ASSEMBLY

No.	Part No.	Description	Series	Qty
0	-----	NOT REQUIRED PART OR SEE NOTE Note: ORDER PARTS FROM AMERICAN DRYER CORP AT 508-678-9000		1
1	A152013	NUT, HEX (#6-32) Note: NUT, HEX (#6-32)	10	2
2	A153008	WASHER, SPLIT LOCK (#6)	10	2
3	A137005	SWITCH, DOOR (SINGLE POLE) Note: SWITCH, DOOR (SINGLE POLE)	10	1
4	A121028	TERMINAL, 1/4" INSUL. (FEMALE) Note: TERMINAL (INSULATED/FEMALE)	10	2
5	A154281	SPACER, NYLON (3/8") Note: SPACER, NYLON (3/8")	10	2
6	A800448	HINGE, MAIN DOOR (12 1/2") Note: HINGE ASSY.	10	1
7	A153565	STUD, SELF-CLINCHING (#6-32X1) Note: STUD, SELF CLINCHING	10	2
8	A881246	HOUSING, DOOR SWITCH	10	1
9	A150201	SCREW, MACHINE (#10-32 X 1/4") Note: SCREW (#10-32 X 1/4")	10	2
10	A121405	GROMMET, RUBBER	10	1

*Color Code (-)=Not Shown #=Series, Serial Prefix or Run No., N=Not Available

Section: MICROPROCESSOR ASSEMBLY

Model: MLG32PDAWW

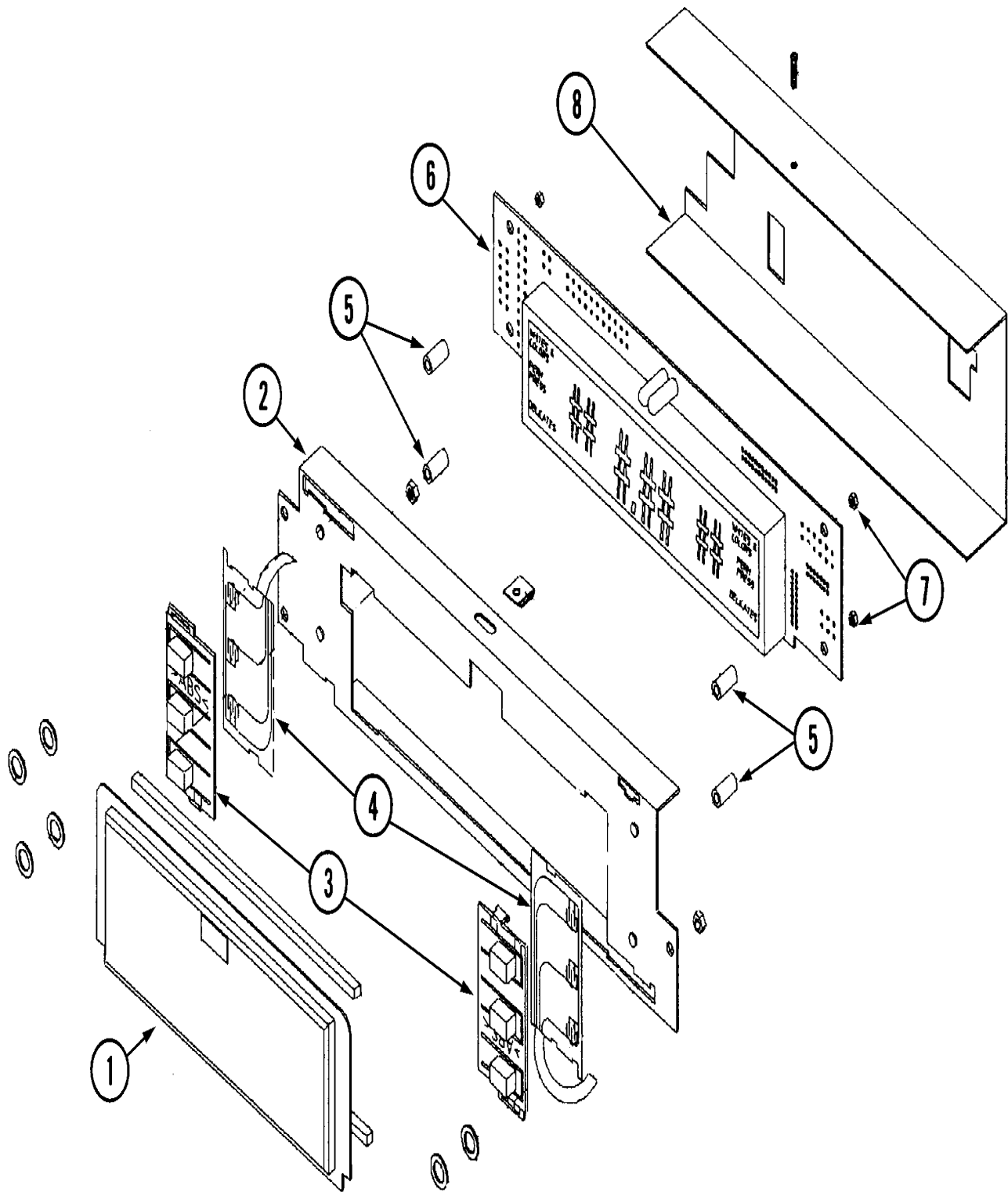

CD21-62

Section: MICROPROCESSOR ASSEMBLY

No.	Part No.	Description	Series	Qty
0	N -----	MANUAL, USE & CARE Note: ORDER PARTS FROM AMERICAN DRYER CORP AT 508-678-9000	10	1
1	A112543	LENS, DISPLAY	10	1
2	A800937	PANEL, MOUNTING	10	1
3	A112544	MEMBRANE SWITCH (PUSH-BUTTON)	10	2
4	A112541	MOLEX, MEMBRANE SWITCH	10	2
5	A154334	STAND-OFF (1/2" X 1/4")	10	4
6	A137244	MICROPROCESSOR BOARD (MLG/PDA) Note: (AFTER SER.#827785UD - WHT) (AFTER SER.#827816UF - ALM)	10	1
6	A882026	MICROPROCESSOR W/LENS (PDA) Note: (PRIOR SER.#827785UD - WHT) (PRIOR SER.#827816UF - ALM)	10	1
7	A152013	NUT, HEX (#6-32)	10	4
8	A311514	COVER, MICROPROCESSOR	10	1

*Color Code (-)=Not Shown #=Series, Serial Prefix or Run No., N=Not Available

Section: LINT COOP ASSEMBLY

Model: MLG32PDAWW

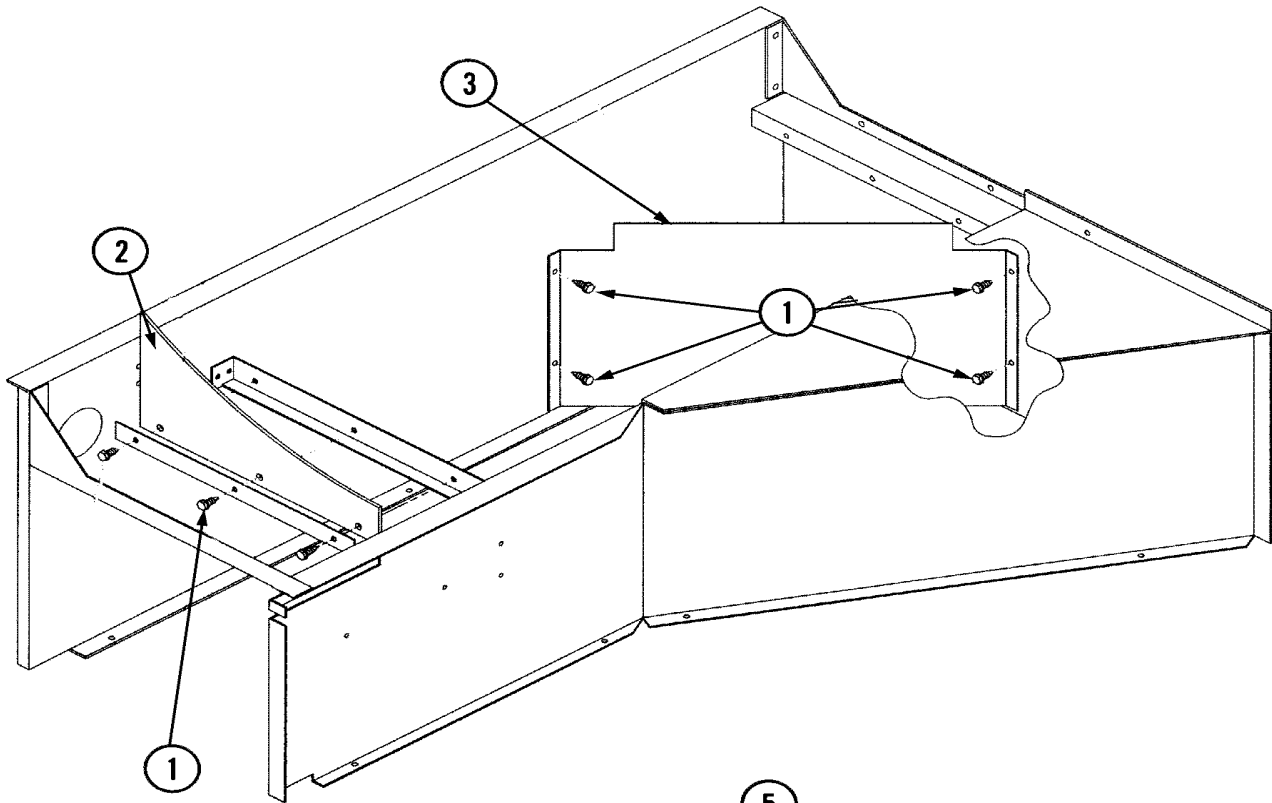

NOTE: DUPLICATE ALL COMPONENTS FOR LOWER LINT COOP ASSEMBLY.

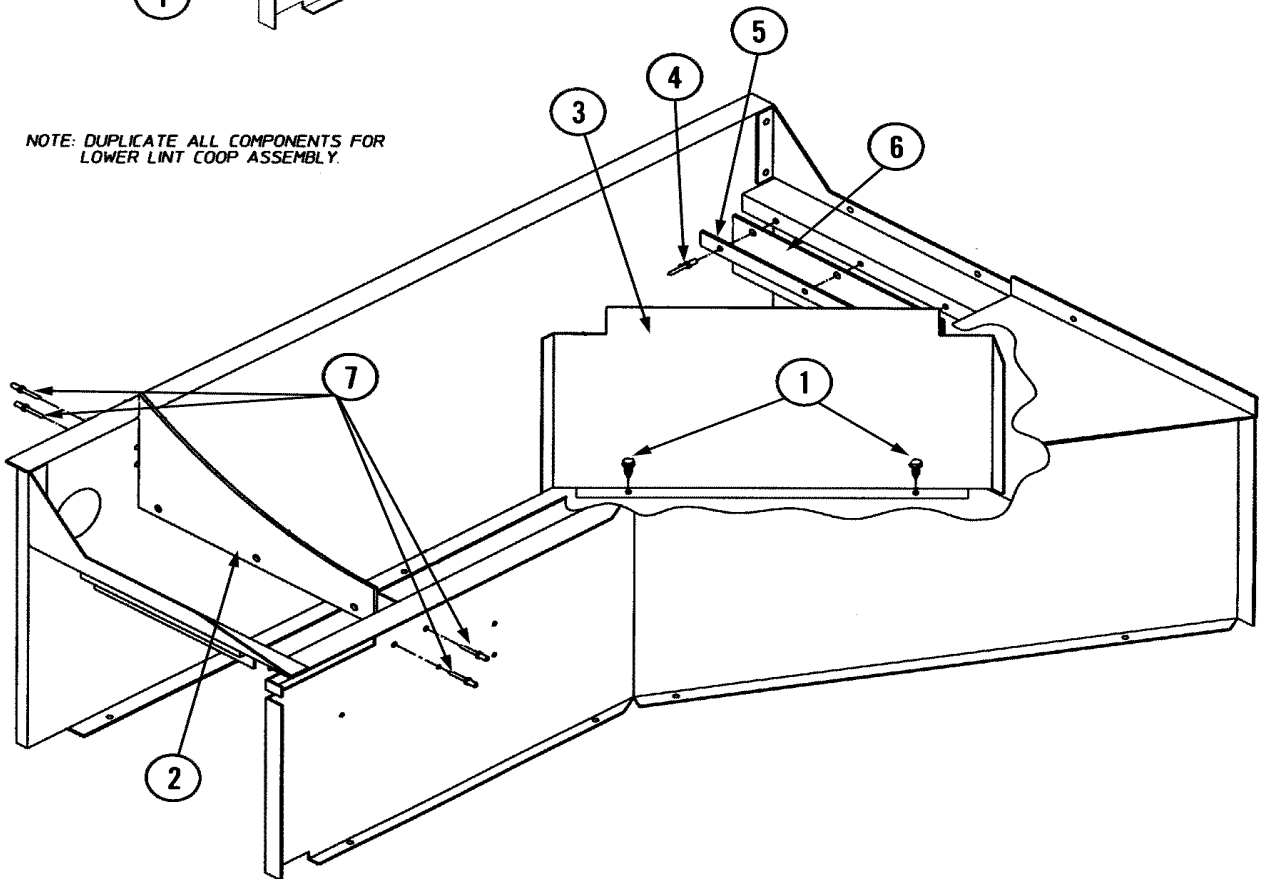

Section: LINT COOP ASSEMBLY

No.	Part No.	Description	Series	Qty
0	-----	NOT REQUIRED PART OR SEE NOTE Note: ORDER PARTS FROM AMERICAN DRYER CORP AT 508-678-9000	10	1
1	A150300	SCREW (#10-32 X 1/2" PH ROUND Note: SCREW (HEX HD #10-16 X 1/2")	10	7
2	A881245	BACK PLATE/FELT SEAL	10	1
3	A311527	BAFFLE, LINT COOP	10	1
-	A800979	LINT COOP WELDMENT	21	1

*Color Code (-)=Not Shown #=Series, Serial Prefix or Run No., N=Not Available

Section: DOOR ASSEMBLY

Model: MLG32PDAWW

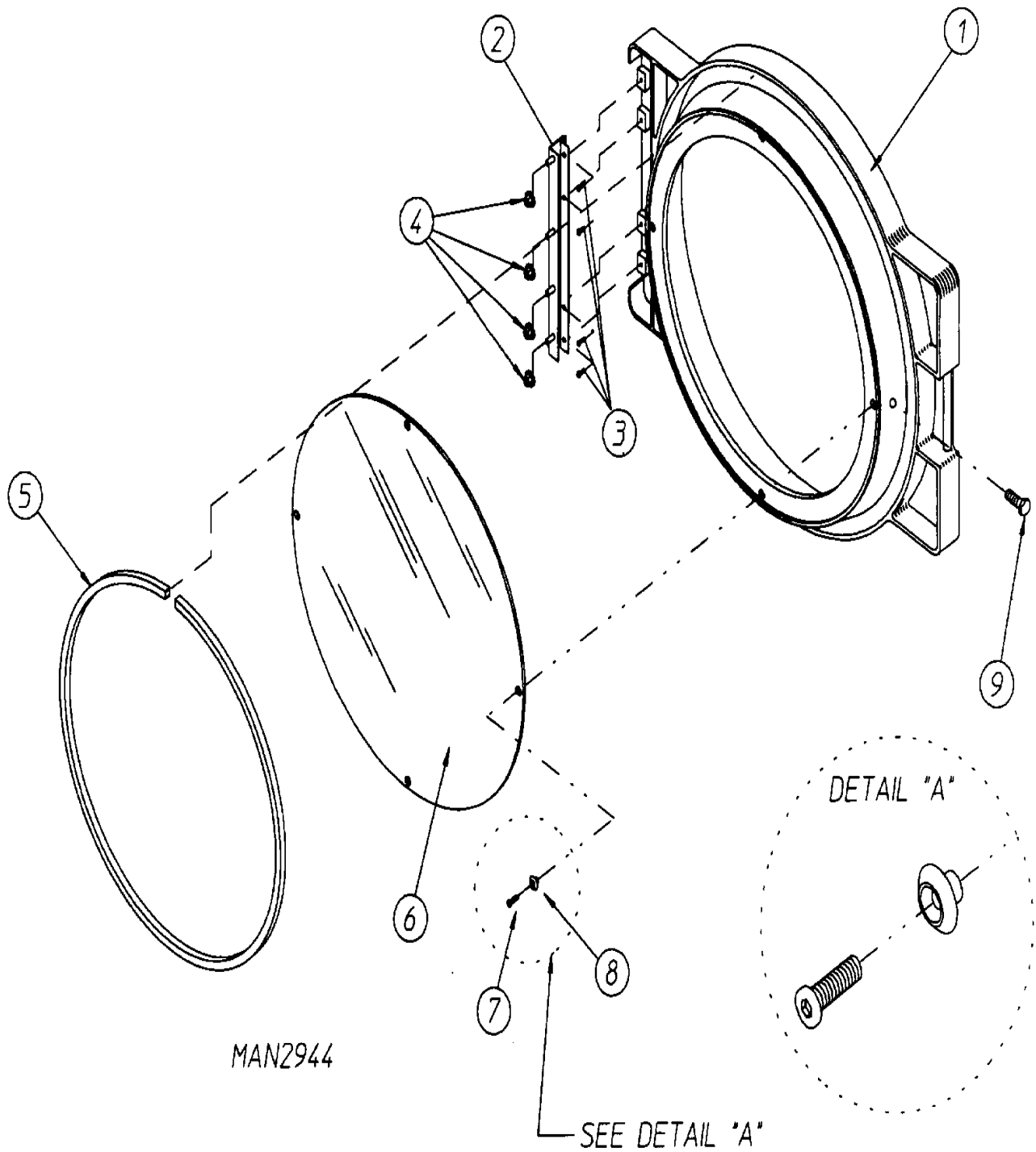

MAN2944

SEE DETAIL "A"

MAN2944

Section: DOOR ASSEMBLY

No.	Part No.	Description	Series	Qty
0	-----	NOT REQUIRED PART OR SEE NOTE Note: ORDER PARTS FROM AMERICAN DRYER CORP AT 508-678-9000	10	1
-	A103062	HINGE PIN	20	2
-	A882963	DOOR FRAME (METAL)	20	1
1	A881422	DOOR ASSY. (LESS HINGE ASSY)	10	1
2	A800448	HINGE, MAIN DOOR (12 1/2")	10	1
3	A150410	SCREW (#10-24 X 3/8" PH HD) Note: SCREW (PH #10-24 X 3/8")	10	4
4	A152014	NUT, FREE SPIN WASH (#20-1/4) Note: WASHER NUT (1/4-20)	10	4
5	A102349	GASKET, DOOR	10	1
-	A170730	ADHESIVE, DOOR GLASS (10.3 OZ) Note: ADHESIVE, DOOR GASKET	10	1
6	A102212	GLASS, DOOR (20-7/16") Note: GLASS, DOOR	10	1
7	A150448	SCREW, S.S. (1/2")	10	4
8	A170319	SPACER, DOOR GLASS Note: SPACER, GLASS	10	4
9	A150431	SCREW (#10 X 7/16" DOME HD) Note: SCREW (HEX HD #10 X 7/16")	10	1

*Color Code (-)=Not Shown #=Series, Serial Prefix or Run No., N=Not Available

Section: LINT DRAWER SWITCH ASSEMBLY (MLG32PDBW*)

Model: MLG32PDAWW

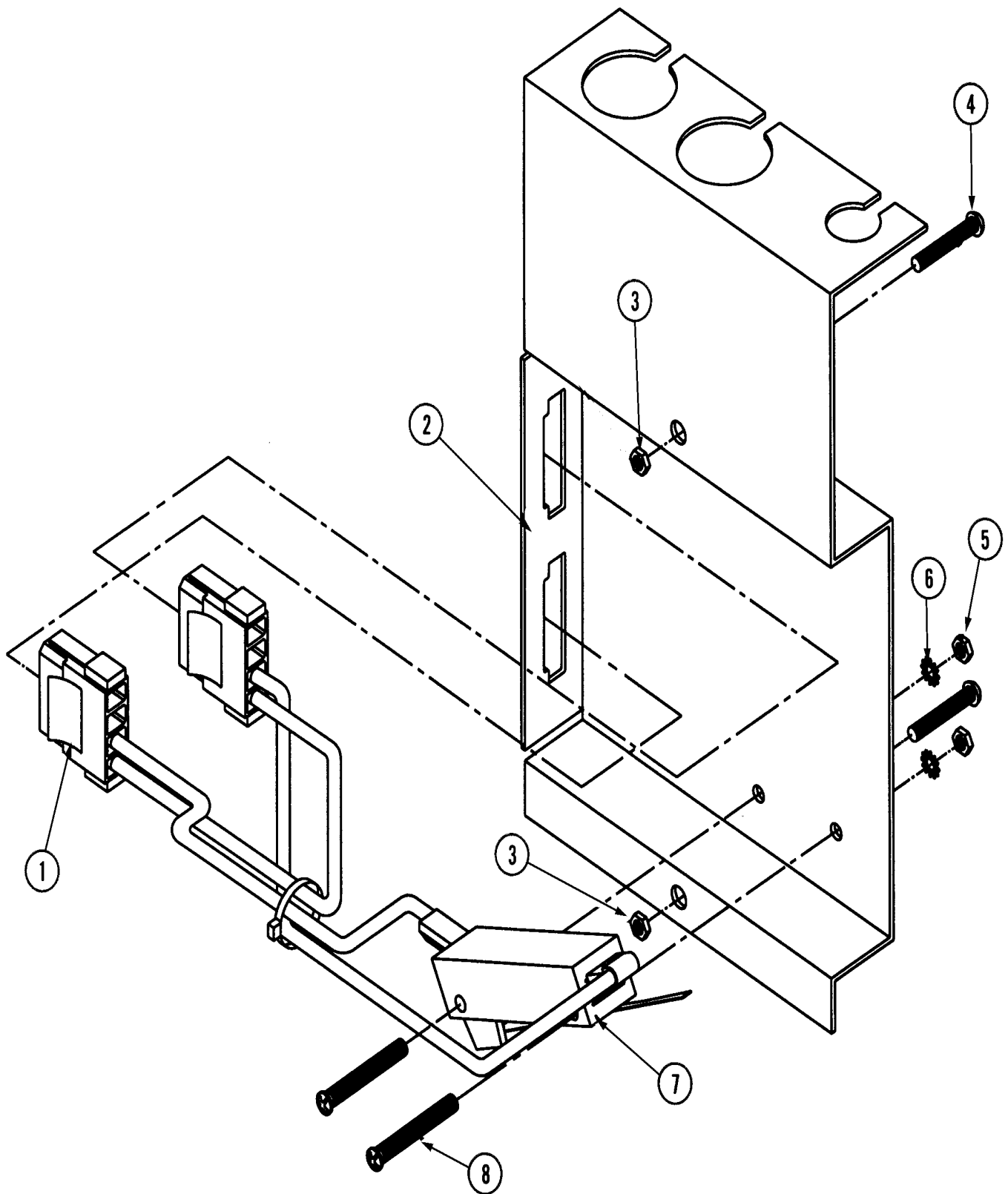

CD21-76

Section: LINT DRAWER SWITCH ASSEMBLY (MLG32)

No.	Part No.	Description	Series	Qty
0	-----	NOT REQUIRED PART OR SEE NOTE Note: ORDER PARTS FROM AMERICAN DRYER CORP. AT 508-678-9000	10	0
1	A882188	HARNESS, SWITCH (UPR)	10	1
1	A882187	HARNESS, SWITCH (LWR)	10	1
2	A882189	SWITCH ASSEMBLY (LWR)	10	1
2	A882185	SWITCH ASSEMBLY (UPR)	10	1
3	A152013	NUT, HEX (#6-32)	10	2
4	A150001	SCREW, MACHINE (#6-32 X 1/2")	10	2
5	A152000	NUT, HEX (#6-32)	10	2
6	A153010	WASHER, STAR (#6)	10	2
7	A136992	SWITCH, LINT DRAWER (ONLY)	10	1
8	A150002	SCREW, MACHINE (RD.HD.)	10	2

*Color Code (-)=Not Shown #=Series, Serial Prefix or Run No., N=Not Available

Section: TEMP. SENSOR BRACKET ASSY. (MLG32PDBW*)

Model: MLG32PDAWW

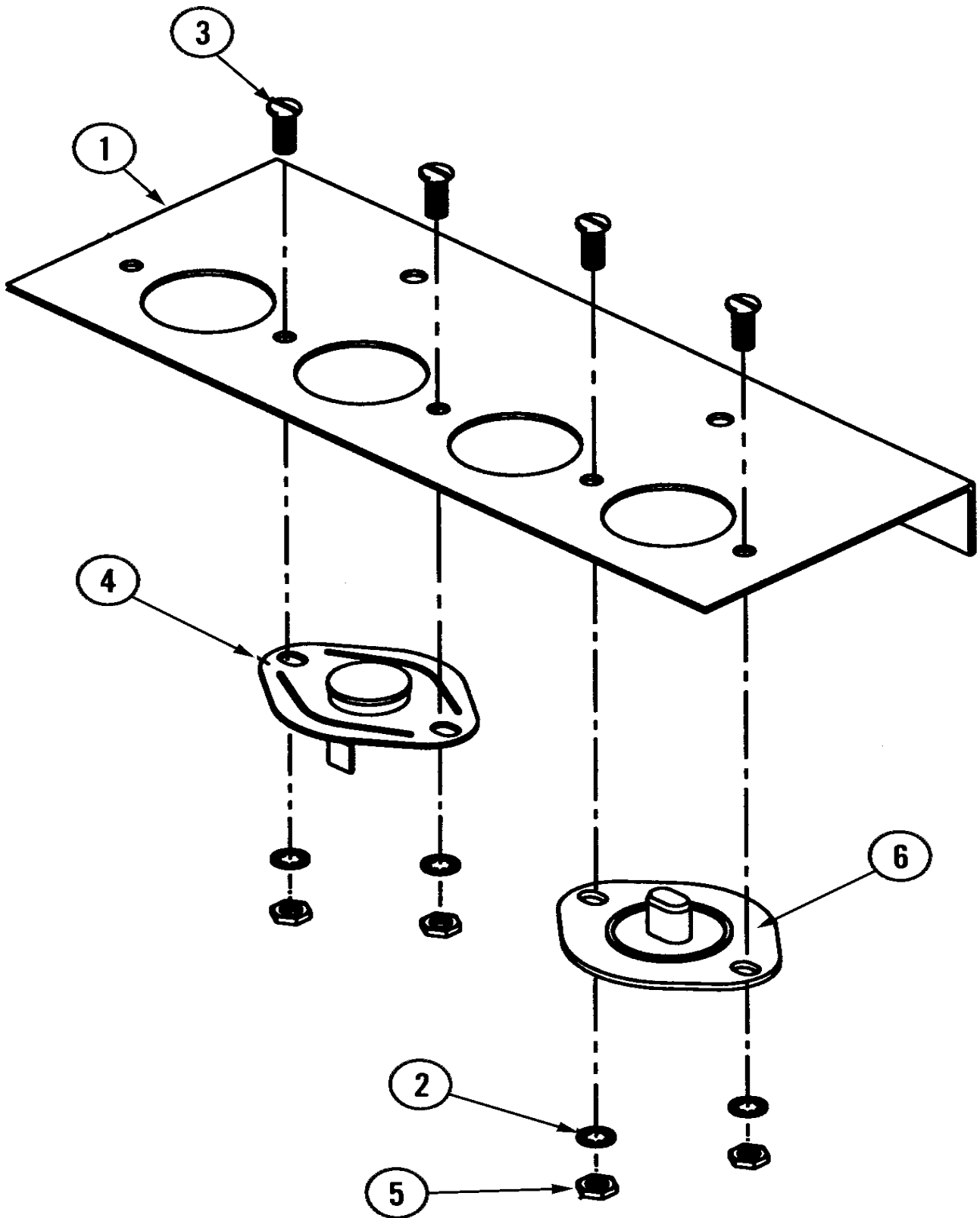

CD21-75

Section: TEMP. SENSOR BRACKET ASSY. (MLG32PD

No.	Part No.	Description	Series	Qty
0	-----	NOT REQUIRED PART OR SEE NOTE Note: ORDER PARTS FROM AMERICAN DRYER CORP AT 508-678-9000		0
1	A311505	BRACKET, TEMP. SENSOR		1
1	A882186	BRACKET, TEMP. SENSOR Note: TEMP. SENSOR BRKT. ASSY.		1
2	A153010	WASHER, STAR (#6)		4
3	A150005	SCREW, PHILL (6-32 X 1/4")RND		4
4	A130118	THERMOSTAT (170 DEGREE)		1
5	A152000	NUT, HEX (#6-32)		4
6	A130117	THERMISTER		1
-	A921988	HARNESS, SENSOR (LWR)		1
-	A821987	HARNESS, SENSOR BRKT. (TOP) Note: HARNESS, SENSOR (UPR)		1

*Color Code (-)=Not Shown #=Series, Serial Prefix or Run No., N=Not Available

Section: TUMBLER BEARING ASSEMBLY (MLG32PDBW*)

Model: MLG32PDAWW

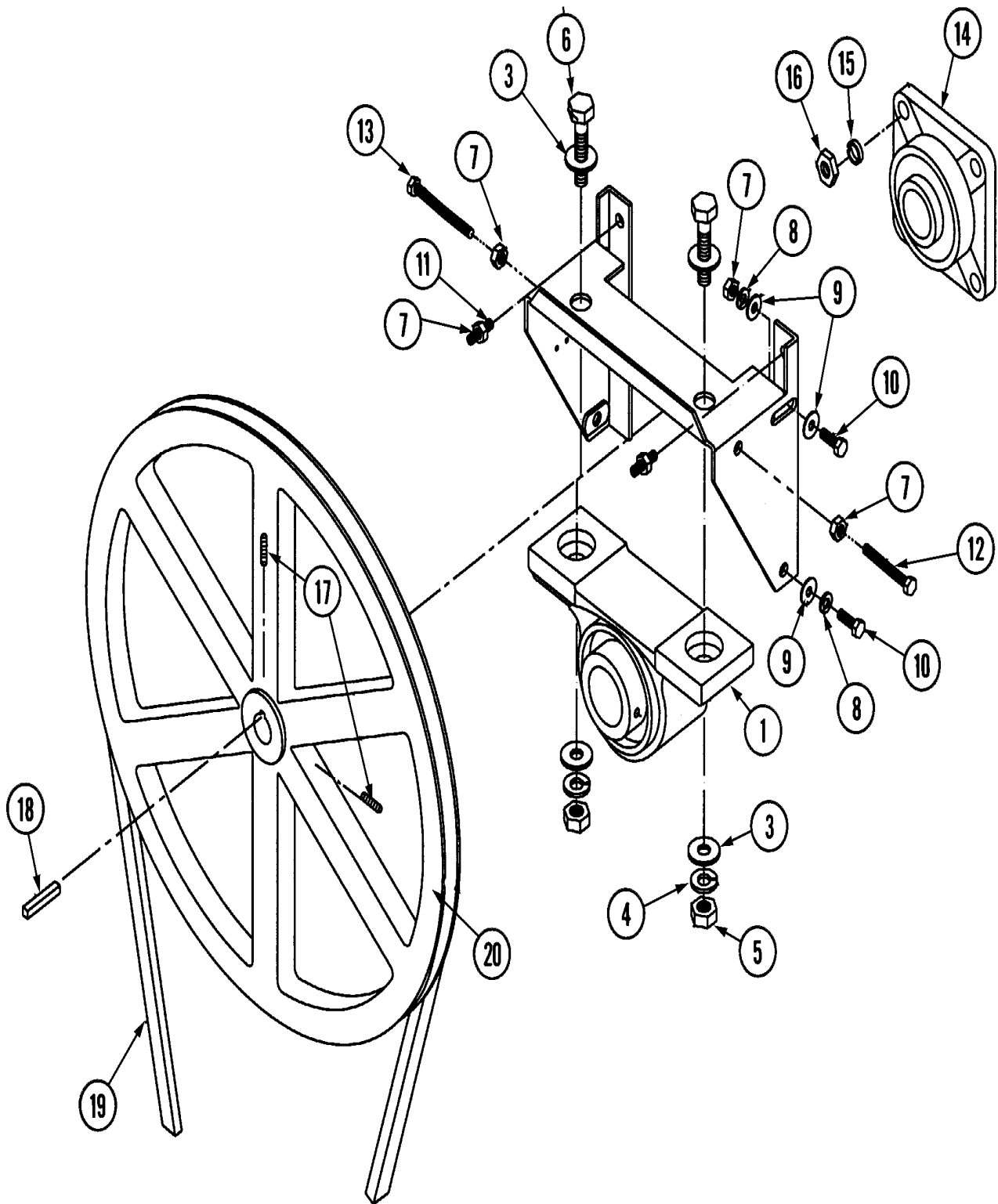

Section: TUMBLER BEARING ASSEMBLY (MLG32PDB)

No.	Part No.	Description	Series	Qty
0	-----	NOT REQUIRED PART OR SEE NOTE Note: ORDER PARTS FROM AMERICAN DRYER CORP AT 508-678-9000	10	0
1	A882251	SUPPORT, TUMBLER	10	1
1	A882250	SUPPORT, TUMBLER ASSY.	10	1
2	A880202	BEARING, PILLOW BLOCK	10	4
3	A153004	WASHER, FLAT (3/8")	10	4
4	A153005	WASHER, LOCK (3/8")	10	2
5	A152005	NUT, HEX (#16-3/8")	10	2
6	A150600	BOLT, MACHINE (#16-3/8 X 11/2)	10	2
7	A152004	NUT, HEX (#18-5/16)	10	6
8	A153002	WASHER, LOCK (5/16")	10	4
9	A153001	WASHER, FLAT (5/16")	10	6
10	A150621	BOLT, MACHINE (#18-5/16X1 1/2)	10	4
11	A150610	SCREW, SET (#18-5/16" X 1 1/2)	10	2
12	A150509	BOLT, MACHINE (5/16-18 X 3")	10	1
13	A150613	BOLT (5/16"X 4")	10	1
14	A880203	BEARING, FLANGE W/SET SCREW	10	1
15	A153005	WASHER, LOCK (3/8")	10	4
16	A152005	NUT, HEX (#16-3/8")	10	4
17	A154301	SCREW, ALLEN (#18-5/16 X 5/16)	10	2
18	A100713	KEY (1/4" X 1/4" X 7/8")	10	1
19	A100100	V-BELT	10	1
20	A101100	PULLEY (18")	10	1

*Color Code (-)=Not Shown #=Series, Serial Prefix or Run No., N=Not Available

Section: GAS VALVE ASSEMBLY (AFTER YU SERIAL#)

Model: MLG32PDAWW

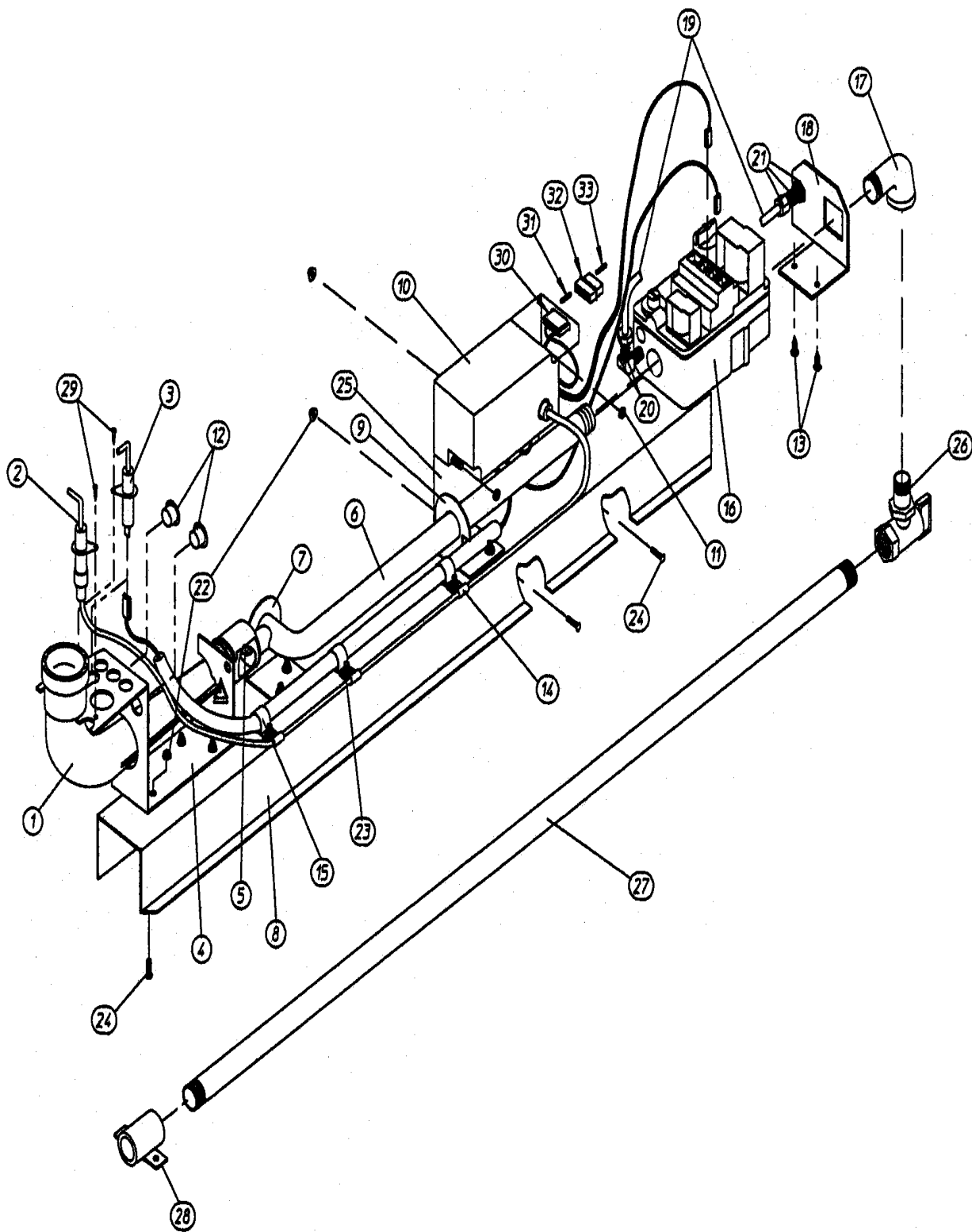

Section: GAS VALVE ASSEMBLY (AFTER YU SERIAL#

No.	Part No.	Description	Series	Qty
1	A141130	TUBE, BURNER W/SHUTTER	10	1
-	A307122	V-BRACKET	24	1
2	A128917	IGNITER W/LEAD	10	2
3	A128918	SENSOR, FLAME	10	1
4	A318009	BRACKET, BURNER TUBE (PSE)	10	1
5	A140828	ORIFICE, BURNER (LP #38) Note: ORIFICE,BURNER-#20,PDA, NTLGAS	10	1
-	A140829	ORIFICE, BURNER (#18,PDB ONLY) Note: ORIFICE,BURNER-#18,PDB,LP GAS	10	1
-	A140811	ORIFICE, BURNER(#41,PDA ONLY) Note: ORIFICE,BURNER-#41,PDA,LP GAS	10	1
-	A140814	ORIFICE, BURNER (NAT. #20) Note: ORIFICE,BURNER-#38,PDB, NTLGAS	10	1
6	A141225	MANIFOLD, SINGLE PORT	10	1
7	A318700	BRACKET, PIPE (BENT)	10	1
-	A319522	VALVE, GAS TRAIN ASSEMBLY Note: VALVE, GAS TRAIN SLIDE	10	1
8	A882721	DIRECT SPARK IGNITION NAT Note: DIRECT SPARK IGNITION NATL GAS	10	1
-	A882722	DIRECT SPARK IGNITION LP GAS	10	1
9	A318711	BRACKET, NOTCHED PIPE	10	1
-	A140411	CONVERSION KIT, GAS VALVE	10	1
10	A128935	MODULE (DSI) Note: DIRECT SPARK IGNITION MODULE	10	1
10	A128937	MODULE (DSI)	25	1
-	A815724	ASSY, BRACKET	25	1
11	A152013	NUT, HEX (#6-32)	10	2
12	A121300	BUSHING, OPEN/CLOSED	10	2
13	A150301	SCREW, TEK (#8-18 X 7/16 PH)	10	2
14	A121491	CLAMP (5/8")	10	3
15	A121492	CLAMP, NYLON (3/16") Note: CLIP, PLASTIC (3/16")	10	3
16	A128927	VALVE, REDUNDANT (1/2" 24VAC) Note: VALVE, REDUNDANT-1/2,24VAC NTL	10	1
16	A880960	VALVE,GAS 1/2" 24 VAC,(LP) Note: VALVE, DIRECT SPARK LP	10	1
17	A142506	ELBOW, STREET (1/2" X 1/2")	10	1
18	A318712	BRACKET, GAS VALVE PIPE	10	1
19	A882157	1/4" ALUMINUM (12" LENGTH)	10	1
20	A143203	ADAPTER, LINE (90 DEG.)	10	1
21	A143259	FITTING, BULKHEAD	10	1
22	A151001	NUT, PAL (#8-32)	10	8
23	A152001	NUT, HEX (#8-32)	10	3
24	A153528	STUD, SELF CLINCHING	10	9
25	A815974	MOUNTING BRACKET, IGNITION DSI	10	1
26	A881367	UNION, SHUT-OFF (1/2")	10	1
27	A142805	PIPE, 1/2" X 34 1/2"	10	1
28	A142934	1/2"COUPLING WITH MOUNTING TAB	10	1
29	A150315	SCREW (#6 X 3/8" PH HD)	10	2
30	A122605	CONNECTOR, 4-PIN SOCKET	10	1
31	A122701	TERMINAL, SOCKET (ONLY)	10	2
32	A122604	CONNECTOR (4 PIN)	10	1
-	A881936	CONVERSION KIT (LP) Note: CONVERSION KIT (LP) PDA MODEL	10	1
33	A122700	TERMINAL, PIN	10	2
-	A882175	GAS VALVE CONVERSION KIT PDB Note: CONVERSION KIT (LP) PDB MODEL	10	1

*Color Code (-)=Not Shown #=Series, Serial Prefix or Run No., N=Not Available

